

**RICOH**

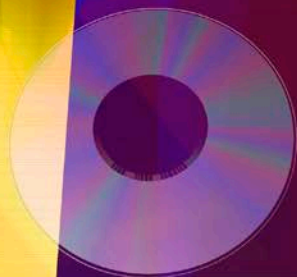

**D135/D136/D137/D138**  
**DETAILED**  
**DESCRIPTIONS**  
**MANUAL**

# D135/D136/D137/D138 DETAILED DESCRIPTIONS - DRAFT

## TABLE OF CONTENTS

<b>1. ADF</b> .....	<b>9</b>
1.1 OVERVIEW.....	9
1.1.1 GENERAL SPECIFICATIONS .....	9
1.1.2 SUPPORTED ORIGINAL SIZES .....	10
1.1.3 COMPONENTS .....	11
1.2 DETAILS .....	12
1.2.1 DRIVE.....	12
1.2.2 ORIGINAL PICK-UP .....	13
1.2.3 BOTTOM PLATE LIFT .....	14
1.2.4 ORIGINAL FEED .....	15
1.2.5 SKEW CORRECTION .....	16
1.2.6 ORIGINAL SIZE DETECTION .....	17
1.2.7 ORIGINAL FEED PROCEDURE .....	18
1.2.8 DUPLEX SCANNING .....	20
1.2.9 JAM DETECTION .....	21
1.2.10 ABNORMAL DETECTION .....	23
<b>2. DRAWER UNIT</b> .....	<b>25</b>
2.1 OVERVIEW.....	25
2.1.1 COMPONENTS .....	25
2.2 DETAILS .....	26
2.2.1 LOCK MECHANISM .....	26
2.2.2 ELECTRICAL SUPPLY .....	31
<b>3. TONER SUPPLY</b> .....	<b>32</b>
3.1 MECHANISM DESCRIPTIONS .....	32
3.1.1 OVERVIEW .....	32
3.2 MECHANISM DETAILS .....	34
3.2.1 TONER FILLING.....	34
3.2.2 TONER SUPPLY .....	36
3.2.3 TONER END / NEAR-END CONTROL.....	38
3.2.4 BOTTLE INFORMATION STORE / BOTTLE LOCK DETECTION .....	40
<b>4. SCANNER</b> .....	<b>41</b>
4.1 MAIN COMPONENTS .....	41
4.1.1 OVERVIEW .....	41
4.1.2 COMPONENTS .....	41
4.2 MECHANISM DETAILS .....	42
4.2.1 SCANNER .....	42
4.2.2 DRIVE.....	43
4.2.3 ORIGINAL SIZE DETECTION .....	44

4.2.4	SENSOR STATE .....	44
4.2.5	ORIGINAL TRANSPORT FROM ADF .....	46
4.2.6	DUST DETECTION .....	47
4.2.7	SCAN POINT SHIFT.....	47
4.2.8	ANTI-CONDENSATION HEATER .....	48
<b>5.</b>	<b>IMAGE PROCESSING .....</b>	<b>49</b>
5.1	MECHANISM DESCRIPTIONS .....	49
5.1.1	BLOCK DIAGRAM .....	49
5.1.2	MECHANISM DETAILS .....	49
<b>6.</b>	<b>LASER UNIT .....</b>	<b>51</b>
6.1	OVERVIEW.....	51
6.1.1	GENERAL.....	51
6.1.2	COMPONENTS .....	51
6.2	DETAILS .....	53
6.2.1	LD UNIT COMPONENTS .....	53
6.2.2	WRITING WITH 40 BEAMS.....	55
6.2.3	LD SAFETY SWITCH .....	55
6.2.4	LINE SCAN.....	56
6.2.5	IMAGE LOCATION CORRECTION .....	57
6.2.6	THERMAL CONTROL .....	57
6.2.7	SHUTTER.....	58
<b>7.</b>	<b>PCDU .....</b>	<b>59</b>
7.1	MECHANISM DESCRIPTIONS .....	59
7.1.1	GENERAL.....	59
7.1.2	AROUND THE DRUM .....	60
7.2	DETAILS .....	61
7.2.1	CHARGE .....	61
7.2.2	DRUM DRIVE .....	62
7.2.3	DRUM CLEANING.....	62
7.2.4	PG-FLUCTUATION REDUCTION TECHNOLOGY .....	63
7.2.5	PPG-DRIVE .....	63
7.2.6	LUBRICANT END DETECTION .....	64
7.2.7	DEMS (DEVELOPMENT ELECTRIC-FIELD MODULATION SYSTEM)	
	65	
<b>8.</b>	<b>DEVELOPMENT UNIT .....</b>	<b>66</b>
8.1	MECHANISM DESCRIPTIONS .....	66
8.1.1	DEVELOPMENT LAYOUT .....	66
8.1.2	DEVELOPMENT DETAILS .....	67
<b>9.</b>	<b>IMAGE TRANSFER BELT (ITB) UNIT .....</b>	<b>71</b>
9.1	MECHANISM DESCRIPTIONS .....	71
9.1.1	GENERAL.....	71
9.1.2	OVERVIEW .....	71
9.2	MECHANISM DETAILS .....	72

<b>10.ITB CLEANING UNIT</b> .....	<b>76</b>
10.1 MACHINE DESCRIPTIONS.....	76
10.1.1 OVERVIEW.....	76
10.1.2 ITB CLEANING MECHANISM .....	78
<b>11.PROCESS CONTROL</b> .....	<b>79</b>
11.1 OVERVIEW.....	79
11.2 COMPONENTS.....	80
11.2.1 PROCESS CONTROL COMPONENTS LAYOUT .....	80
11.2.2 SENSORS FOR POTENTIAL CONTROL.....	80
11.2.3 SENSORS FOR TONER SUPPLEMENT .....	82
11.3 INITIAL SETTINGS .....	82
11.3.1 INSTALLATION, DEVELOPER REPLACEMENT .....	83
11.3.2 OTHER INITIAL SETTINGS .....	83
11.4 POTENTIAL CONTROL.....	84
11.4.1 OUTLINE .....	84
11.4.2 POTENTIAL CONTROL EXECUTION CONDITION.....	85
11.4.3 RESULT.....	85
11.5 TONER SUPPLY CONTROL.....	86
11.5.1 OUTLINE .....	86
11.5.2 ID PATTERN DETECTION TONER SUPPLY .....	86
11.5.3 OPERATION.....	87
11.6 <a href="#">LIST OF PROCESS CONTROL ACRONYMS</a> .....	87
<b>12.PAPER TRANSFER ROLLER (PTR) UNIT</b> .....	<b>88</b>
12.1 MACHINE DESCRIPTIONS.....	88
12.1.1 GENERAL.....	88
12.1.2 COMPONENTS LAYOUT .....	88
12.1.3 PAPER SEPARATION.....	89
12.1.4 PAPER TRANSFER ROLLER LIFT (PTR LIFT) .....	89
12.1.5 PTR RELEASE (SEPARATION).....	92
12.1.6 PTR CLEANING.....	93
12.1.7 PTR DRIVE.....	94
12.1.8 AC TRANSFER METHOD (PRO C5100S/PRO C5110S ONLY).....	95
<b>13.FUSING UNIT</b> .....	<b>97</b>
13.1 OVERVIEW.....	97
13.1.1 FUSING UNIT LAYOUT.....	97
13.1.2 ELECTRICAL COMPONENTS .....	98
13.2 DETAIL.....	100
13.2.1 FUSING MECHANISM.....	100
13.2.2 THERMAL CONTROL .....	102
13.2.3 FUSING ANTI-OVERHEAT .....	104
13.2.4 FUSING DRIVE .....	106
13.2.5 ROTATION DETECTION.....	106
13.2.6 PRESSURE MECHANISM .....	107
13.2.7 FUSING NIP-BAND ADJUSTMENT (ENVELOPE).....	108
13.2.8 JAM DETECTION .....	109
13.2.9 CLEANING MECHANISM (CH-C1 PRO ONLY) .....	110

13.2.10	FUSING BELT SMOOTHING ROLLER (CH-C1 PRO ONLY) ...	112
13.2.11	FUSING HEAT-SHUTOFF / COOLING MECHANISM .....	114
13.2.12	PRESSURE ROLLER COOLING (CH-C1 PRO ONLY).....	114
<b>14.</b>	<b>PAPER TRANSPORT BELT (PTB).....</b>	<b>115</b>
14.1	MECHANISM DESCRIPTIONS.....	115
14.1.1	LAYOUT.....	115
14.1.2	TRANSPORT BELT MECHANISM .....	116
14.1.3	PTB TRANSPORT UNIT SET SENSOR.....	116
<b>15.</b>	<b>PAPER FEED UNIT .....</b>	<b>117</b>
15.1	MECHANISM DESCRIPTIONS.....	117
15.1.1	LAYOUT.....	117
15.2	MECHANISM DETAILS .....	118
15.2.1	BANK .....	118
15.2.2	TRAY PULL-IN / PULL-IN RELEASE.....	130
<b>16.</b>	<b>BYPASS.....</b>	<b>132</b>
16.1	MECHANISM DESCRIPTIONS.....	132
16.1.1	LAYOUT.....	132
16.2	MECHANISM DETAILS .....	133
<b>17.</b>	<b>VERTICAL TRANSPORT.....</b>	<b>139</b>
17.1	MECHANISM DESCRIPTIONS.....	139
17.1.1	LAYOUT DIAGRAM .....	139
17.2	MECHANISM DETAILS .....	140
<b>18.</b>	<b>PAPER REGISTRATION .....</b>	<b>142</b>
18.1	GENERAL DESCRIPTIONS .....	142
18.1.1	GENERAL LAYOUT.....	142
18.1.2	TRANSPORT PATH LAYOUT .....	142
18.1.3	DRIVE LAYOUT.....	143
18.2	MECHANISM DETAILS .....	144
18.2.1	REGISTRATION .....	144
18.2.2	PAPER THICKNESS / DOUBLE FEED DETECTION.....	145
<b>19.</b>	<b>PAPER EXIT AND DUPLEXING .....</b>	<b>148</b>
19.1	MECHANISM DESCRIPTIONS.....	148
19.1.1	SECTION LAYOUT .....	148
19.1.2	TRANSPORT PATH .....	149
19.1.3	DRIVE LAYOUT.....	150
19.2	MECHANISM DETAILS .....	151
19.2.1	SIDE-TO-SIDE REGISTRATION .....	151
19.2.2	INVERT / EXIT .....	153
19.2.3	DUPLEX.....	155
<b>20.</b>	<b>PAPER PURGE .....</b>	<b>157</b>
20.1	MECHANISM DESCRIPTIONS.....	157
20.1.1	MECHANISM DETAILS .....	158

<b>21.ELECTRICAL COMPONENTS.....</b>	<b>159</b>
21.1 BLOCK DIAGRAM .....	159
21.1.1 BOARD LOCATION .....	159
21.2 MECHANISM DESCRIPTIONS.....	163
21.2.1 EACH BOARD OUTLINE .....	163
21.2.2 FUSE LIST .....	164
21.2.3 HDD DETAILS (MEMORY CAPACITY FOR STORED DOC.)...	170
<b>22.USED TONER COLLECTION .....</b>	<b>171</b>
22.1 MECHANISM DESCRIPTIONS.....	171
22.1.1 GENERAL .....	171
22.1.2 LAYOUT .....	171
22.1.3 COMPONENTS .....	171
22.2 MECHANISM DETAILS .....	172
22.2.1 USED TONER TRANSFER .....	172
22.2.2 USED TONER BOTTLE TRANSFER / USED TONER BOTTLE	
DRIVE / TORQUE SENSOR PART .....	173
22.2.3 EACH SENSOR DETECTION .....	174
<b>23.BUFFER PASS UNIT TYPE 5020 .....</b>	<b>175</b>
23.1 OVERVIEW .....	175
23.1.1 GENERAL SPECIFICATIONS .....	175
23.1.2 OVERVIEW LAYOUT .....	176
23.1.3 DRIVE LAYOUT.....	177
23.2 DETAILS .....	178
23.2.1 PAPER PATH .....	178
23.2.2 PAPER COOLING .....	179
<b>24.COVER INTERPOSER TRAY CI4010 .....</b>	<b>180</b>
24.1 OVERVIEW .....	180
24.1.1 GENERAL SPECIFICATIONS .....	180
24.1.2 SUPPORTED PAPER.....	180
24.1.3 MAIN COMPONENTS .....	182
24.1.4 ELECTRICAL COMPONENT LAYOUT .....	182
24.1.5 DRIVE LAYOUT.....	183
24.2 DETAILS .....	184
24.2.1 PAPER FEED .....	184
<b>25.COVER INTERPOSER TRAY CI4020 .....</b>	<b>185</b>
25.1 OVERVIEW .....	185
25.1.1 GENERAL SPECIFICATIONS .....	185
25.1.2 ELECTRICAL COMPONENTS .....	185
25.1.3 DRIVE LAYOUT.....	186
25.2 DETAILS .....	188
<b>26.9-BIN MAILBOX CS4010 .....</b>	<b>189</b>
26.1 OVERVIEW .....	189
26.1.1 GENERAL SPECIFICATIONS .....	189
26.1.2 OVERVIEW LAYOUT .....	190

26.1.3	DRIVE LAYOUT .....	191
26.1.4	ELECTRICAL COMPONENTS .....	192
26.2	DETAILS .....	193
26.2.1	BASIC OPERATION .....	193
26.2.2	PAPER TRAY FULL DETECTION .....	194
26.2.3	JAM DETECTION .....	195
<b>27</b>	<b>DECURLER UNIT DU5020 .....</b>	<b>197</b>
27.1	OVERVIEW .....	197
27.1.1	GENERAL SPECIFICATIONS .....	197
27.1.2	ELECTRICAL COMPONENTS .....	198
27.2	MECHANISM DETAILS .....	199
27.2.1	DECURLER ROLLER UNIT .....	199
<b>28</b>	<b>MULTI-FOLDING UNIT FD 4000 .....</b>	<b>201</b>
28.1	OVERVIEW .....	201
28.1.1	GENERAL LAYOUT .....	201
28.1.2	TRANSPORT LAYOUT .....	202
28.1.3	ROLLER LAYOUT .....	203
28.1.4	TRANSPORT SENSOR LAYOUT .....	205
28.1.5	DRIVE / SOLENOID LAYOUT .....	206
28.1.6	ELECTRICAL COMPONENT LAYOUT (TRANSPORT) .....	208
28.1.7	ELECTRICAL COMPONENTS LAYOUT (VERTICAL TRANSPORT)	
	210	
28.1.8	ELECTRICAL COMPONENTS LAYOUT (1ST, 2ND, 3RD, STOPPER).....	211
28.1.9	ELECTRICAL COMPONENTS LAYOUT (REGISTRATION, 1ST FOLD) 212	
28.1.10	ELECTRICAL COMPONENTS (2ND FOLD, CREASE).....	213
28.1.11	ELECTRICAL COMPONENTS (ELECTRICAL PARTS) .....	214
28.2	DETAILS .....	215
28.2.1	FOLD PROCESS .....	215
28.2.2	EACH FOLD OPERATION .....	216
28.2.3	DOUBLE FOLD .....	219
28.3	FOLD ADJUSTMENT .....	221
28.3.1	FOLD MEASUREMENT LOCATION .....	221
28.3.2	CREASE ROLLER ADJUSTMENT .....	223
28.3.3	FOLD-AREA ADJUSTMENT .....	224
<b>29</b>	<b>LCIT RT4020 .....</b>	<b>232</b>
29.1	OVERVIEW .....	232
29.1.1	SPECIFICATIONS .....	232
29.1.2	LAYOUT .....	233
29.2	DETAILS .....	234
29.2.1	TRAY SHIFT UP / DOWN .....	234
29.2.2	SIZE DETECTION .....	236
29.2.3	PAPER REMAINING AMOUNT DETECTION .....	236
29.2.4	PAPER-END DETECTION .....	236

<b>30.LCIT RT4030 .....</b>	<b>237</b>
30.1 OVERVIEW .....	237
30.1.1 OVERVIEW LAYOUT .....	237
30.1.2 DRIVE LAYOUT.....	238
30.1.3 ELECTRICAL COMPONENTS LAYOUT .....	239
30.1.4 OTHERS LAYOUT .....	240
30.2 DETAILS .....	240
30.2.1 FEED / SEPARATION .....	240
30.2.2 FEED / SEPARATION OPERATION .....	241
30.2.3 TRAY SHIFT UP / DOWN.....	242
30.2.4 PAPER SIZE DETECTION .....	243
30.2.5 PAPER REMAINING AMOUNT DETECTION .....	244
30.2.6 PAPER END DETECTION.....	245
30.2.7 PAPER EXIT .....	246
<b>31.2,000-SHEET BOOKLET FINISHER (SR4100) 3,000-SHEET FINISHER (SR4090) .....</b>	<b>247</b>
31.1 OVERVIEW .....	247
31.1.1 GENERAL SPECIFICATIONS .....	247
31.1.2 LAYOUT.....	248
31.2 DETAILS .....	251
31.2.1 SHIFT OPERATION (SHIFT TRANSPORT).....	251
31.2.2 PRE-STACK OPERATION (IN CORNER STAPLING) .....	252
31.2.3 PRE-STACK OPERATION (IN BOOKLET STAPLING).....	253
31.2.4 UPPER TRAY SHIFT DRIVE / LIMIT SENSOR / FULL SENSOR.....	254
31.2.5 PULL-IN ROLLER / PAPER STACK HOLDER .....	255
31.2.6 CORNER STAPLING.....	257
31.2.7 SADDLE-SHAPE STAPLING (BOOKLET STAPLING).....	261
<b>32.FINISHER SR 4110.....</b>	<b>269</b>
32.1 OVERVIEW .....	269
32.1.1 GENERAL SPECIFICATIONS .....	269
32.1.2 SUPPORTED PAPER.....	270
32.1.3 ヒューズ一覧表 FUSE LIST .....	272
32.1.4 COMPONENT LAYOUT .....	274
32.1.5 ELECTRICAL COMPONENT LAYOUT .....	275
32.1.6 DRIVE LAYOUT.....	279
32.2 MECHANISM DETAILS .....	281
32.2.1 INVERTER.....	281
32.2.2 SHIFT TRAY .....	283
32.2.3 PRE-STACK .....	284
32.2.4 STAPLE TRAY JOGGER.....	285
32.2.5 STAPLE .....	287
32.2.6 PUNCH (2-HOLE PUNCH UNIT).....	292
32.2.7 JAM DETECTION .....	294
32.2.8 DIP SW .....	295
<b>33.OUTPUT JOGGER UNIT TYPE M2 (D705) .....</b>	<b>296</b>

33.1	MACHINE DESCRIPTIONS .....	296
33.1.1	LAYOUT .....	296
33.2	MECHANISM .....	297
<b>34.</b>	<b>Z-FOLDING UNIT .....</b>	<b>298</b>
34.1	OVERVIEW .....	298
34.1.1	GENERAL .....	298
34.1.2	OVERVIEW LAYOUT .....	299
34.1.3	ELECTRICAL COMPONENTS LAYOUT .....	300
34.1.4	DRIVE LAYOUT .....	301
34.2	DETAILS .....	302
34.2.1	FOLDING .....	302
34.2.2	Z-FOLDING AREA ADJUSTMENT .....	305
34.2.3	.....	305
34.2.4	Z-FOLDING GAP ADJUSTMENT .....	306

# 1. ADF

## 1.1 OVERVIEW

### 1.1.1 GENERAL SPECIFICATIONS

Items		Descriptions	Remarks
Type		Auto-duplex-scan sheet-through DF	Single-path duplex sheet-through DF
Supported Original Size	Simplex	A3, A4, A5, B4, B5, B6, DLT, LG, LT, HLT, Banner Paper (~1260mm)	40~128g/m2
	Duplex	A3, A4, A5, B4, B5, (B6), DLT, LG, LT, HLT	52~128g/m2 *B6 can only pass through.
Original Standard Position		Rear left corner upward.	
Original Feed Order		From the top original.	
Separation Method		Feed belt and separation roller	
Scanning Method		Sheet pass method ( <b>Face</b> : White guide plate, <b>Back</b> : Color CIS + white roller)	
Placable Original Capacity		220 sheets (81.4g/mm2) Stack height: 25 mm or less.	250 Sheets (Ricoh Mypaper)
CPM		500mm/s (BW) 310.5mm/s (Color)	
Scanning Throughput	Simplex	<b>Copy:</b> 80ipm: LT LEF, A4 LEF 1 to 1 (BW / Color) <b>Scan:</b> 100ipm (200 / 300dpi): LT LEF, A4 LEF 1 to 1 (Color)	
	Duplex	<b>Copy:</b> 80ipm: LT LEF, A4 LEF 1 to 1 (BW / Color) <b>Scan:</b> 200ipm (200 / 300dpi): LT LEF, A4 LEF 1 to 1 (Color)	
Supported Magnification Ratios (Face / Back)		66.7 % (750mm/s) only	25 to 400% on the system.
Dimensions (W x D x H)		587 (W) x 520 (D) x 175 (H)	
Weight		13.9kg or less	
Power Source		DC24V, DC12V, DC5V	Supplied from the main machine.
Power Consumption		72.2W or less	

**Comment [オブライエン1]:** Duplex is single pass, so why the difference – CIS width limitation?

**Comment [オブライエン2]:** I'm sorry but I don't understand this

RE:

This item means "How degree of magnification this ADF (CIS) can apply to image-data".

And this description means "ADF (CIS) actually can make image-data in 66.7% or of course 100% magnification ratio."

Thanks – but I will ask for more about this

### 1.1.2 SUPPORTED ORIGINAL SIZES

Paper Thickness		35kg	40kg	45kg	55kg	70kg	90kg	110kg	Tracing paper
		40.7 g/m2	46.5 g/m2	52.8 g/m2	64 g/m2	81.4 g/m2	105 g/m2	128 g/m2	
		11lbs	12.5lbs	14lbs	17lbs	22lbs	28lbs	34lbs	TA, TE, TC
Quantity		250 Sheets		250 Sheets		220 Sheets	60 Sheets	50 Sheets	1 Sheet
Original Size	A3/A4	○	●	●	●	●	●	●	▲
	A5	○	●	●	●	●	●	●	-
	B4/B5	○	●	●	●	●	●	●	▲
	B6P	-	○	○	○	○	○	○	-
	DLT	○	●	●	●	●	●	●	-
	LT	○	●	●	●	●	●	●	-
	HLT	○	●	●	●	●	●	●	-
	F	○	●	●	●	●	●	●	-

- : Possible in simplex and duplex
- : Simplex only
- ▲: SADF Simplex only
- : Not supported

### 1.1.3 COMPONENTS

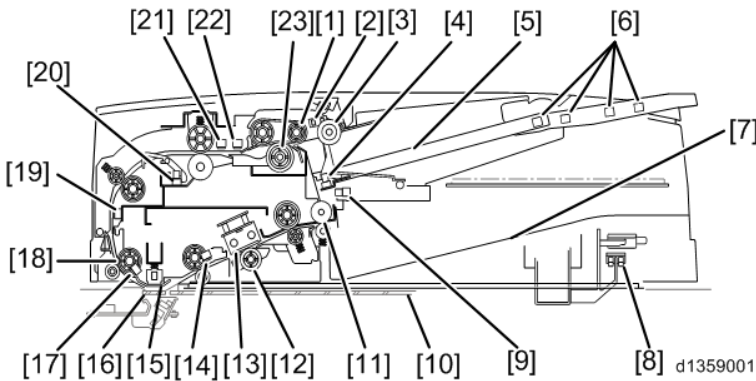

**Comment [ n 3]:** 12/25/12 Modified

1	Feed Belt	13	CIS
2	Bottom Plate Lift Sensor	14	Exit Sensor
3	Pickup Roller	15	White Plate
4	Original Set Sensor	16	ADF Exposure Glass
5	Original Tray (Bottom Plate)	17	Registration Sensor
6	Original Size Sensor	18	Pre-Scanning Entrance Roller
7	Exit Tray	19	Interval Sensor Scanning Roller
8	Open / Close Sensor	20	Original Width Sensor
9	Bottom Plate HP Sensor	21	Skew Correction Sensor
10	Exposure Glass (Book Mode)	22	Separation Sensor
11	Exit Roller	23	Separation Roller
12	White Roller		

**1. Original Pickup**

The pickup roller feeds in original from the tray.

**2. Original Feed / Separation**

With the paper feed belt and the separation roller, original is fed / separated.

**3. Original Size Detection**

Five original width sensors and **four** original length sensors detect the size.

**4. Duplex Original Scanning**

**A CCD (inside the scanner unit, below the ADF) scans the front side, and a CIS (inside the ADF) scans the rear side.**

**Comment [ n 4]:** From V-C3

## 1.2 DETAILS

### 1.2.1 DRIVE

Drive correlation diagram between the motors and the rollers

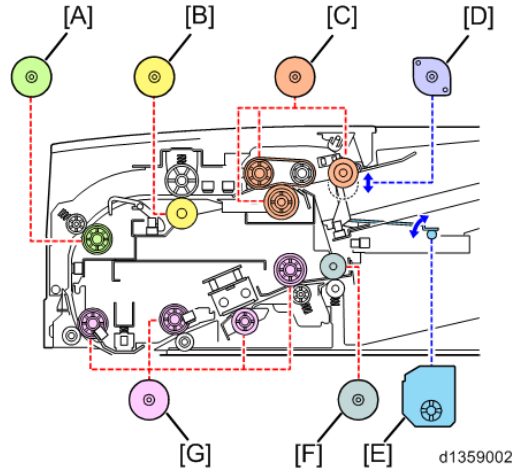

A	Relay Motor	E	Tray Lift Motor
B	Entrance Motor	F	Exit Motor
C	Feed Motor	G	Transport Motor
D	Pick-up Roller Lift Motor		

## 1.2.2 ORIGINAL PICK-UP

### ◆ Original Detection

When an original is placed on the original tray correctly, the edge of the original pushes up the feeler of the original sensor.

### ◆ Pickup Roller Shift up / down

When no original is placed, the pickup roller [C] is in the upper position (released). When the original set sensor detects an original, the pickup roller lift motor [A] turns ON. When the lift cam [E] releases the pickup lever [D], the pickup roller [C] moves down. To lift the pickup roller [C] away from the paper, the pickup lift motor [A] turns on until the pick-up roller HP sensor [B] turns off. Then the pickup roller lift motor [A] turns off.

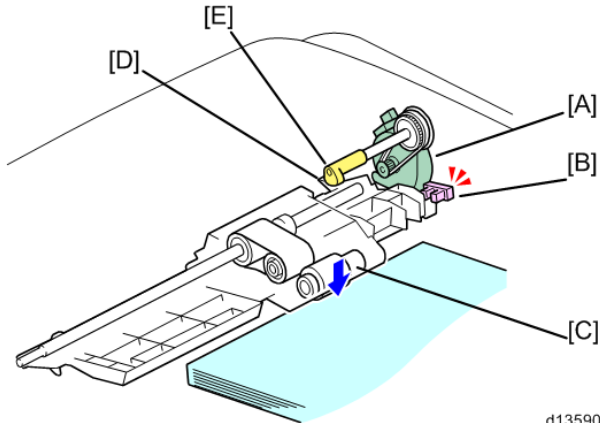

d1359003

### Pickup Roller Down Timing

- When the machine detects that an original has just been placed
- When the trailing edge of an original passes the skew correction sensor (except for the final sheet of an original). For A4 LEF / LT LEF, when the rear edge of the original passes the registration sensor.

### Pickup Roller Lift Timing

- When the leading edge of an original passes the skew correction sensor
- Just after the main machine power turns on
- When the ADF top cover is opened
- When there is an original jam

### 1.2.3 BOTTOM PLATE LIFT

When the machine detects that an original has just been placed, the pickup roller drops (the pick-up roller HP sensor turns off), then the bottom plate lift motor [A] turns, and the lift lever [B] lifts the bottom plate. The bottom plate lift sensor [C] (on the pickup roller holder) detects when the bottom plate is at the correct position for original feed, and the motor [A] stops. When the sensor [C] turns off during original feed, the bottom plate lift motor [A] turns on until the sensor turns on again. This mechanism ensures that the top of the original is always at the correct height for feed, even when the maximum number of sheets is stacked in the feeder [220 sheets (81.4 g/m<sup>2</sup>)]. At the end of a job, the bottom plate lift motor moves the bottom plate down until the bottom plate HP sensor detects it.

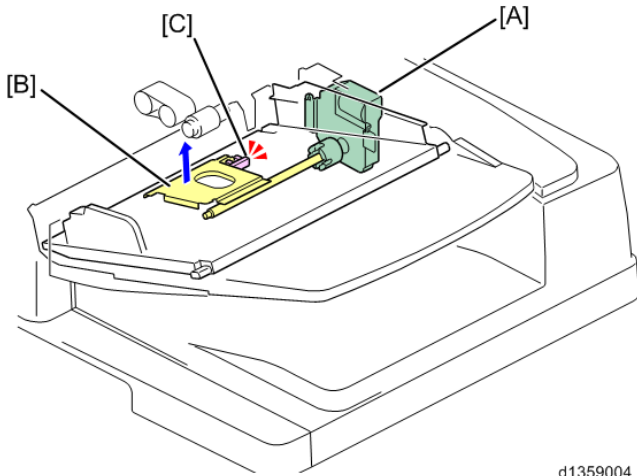

d1359004

### 1.2.4 ORIGINAL FEED

◆ **Feed / Separation**

The separation mechanism uses the FRR method, with a feed belt [A] and separation roller [C]. When the pickup roller [B] feeds two or more sheets into the machine, the separation roller [C] rotates backward to push all sheets back to the original tray except the top one.

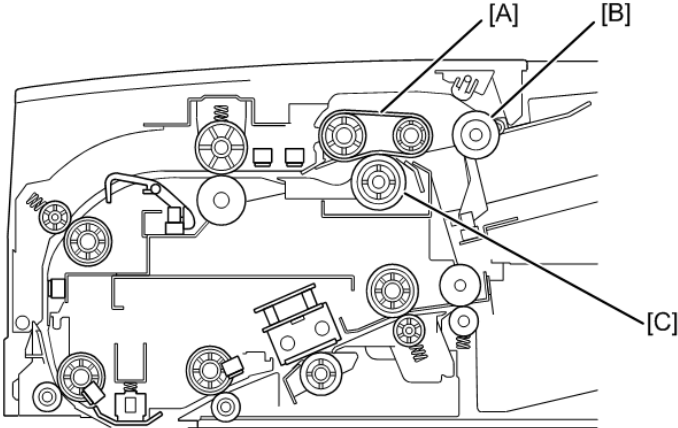

d1359005

Then one sheet of original remains and the separation roller rotates forward due to the torque limiter included in the separation roller. Then the feed belt transfers the original to the entrance roller.

### 1.2.5 SKEW CORRECTION

The skew correction sensor detects the leading edge of the original after it passes through the separation area. When the leading edge reaches the entrance roller, the paper is fed a bit more so that it bumps into the entrance roller [C], to make slack for skew adjustment.

For small paper (B6, A5, B5, HLT) or duplex printing, after detection by the interval sensor [E], the original bumps into the pre-scanning roller [D] (this is a second skew correction, in addition to the entrance roller).

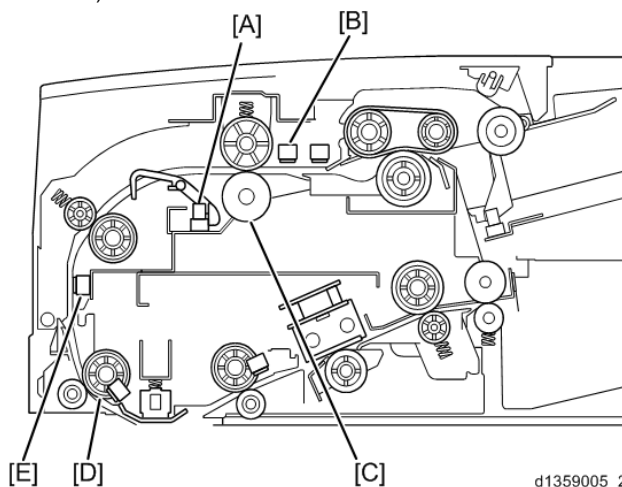

d1359005\_2

A	Original Width Sensor	D	Scanning Roller
B	Skew Correction Sensor	E	Interval Sensor
C	Entrance Roller		

With SP6020-001, the 2nd skew correction can be enabled for all paper sizes. But if this is done, the process speed becomes slower.

### 1.2.6 ORIGINAL SIZE DETECTION

Five original width sensors detect the width of the original just when the leading edge of the original passes the interval sensor. Four original length sensors on the original table detect the length. These two pieces of size information summarize the original size.

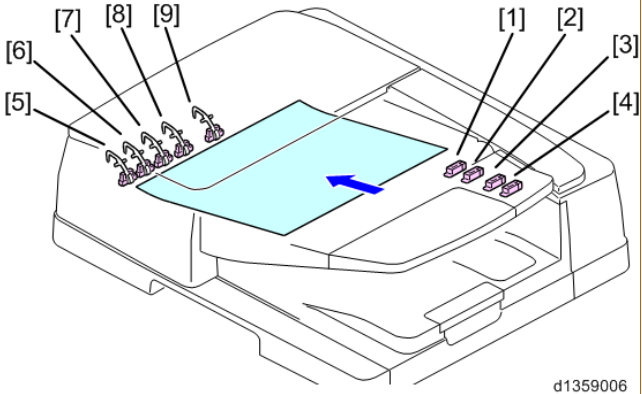

d1359006

**Comment [ n 5]:** 12/25 Modified.

1	Original Size Sensor (A4 LEF, LT LEF)	6	Original Width Sensor 4
2	Original Size Sensor (B5)	7	Original Width Sensor 3
3	Original Size Sensor (A4)	8	Original Width Sensor 2
4	Original Size Sensor (LG)	9	Original Width Sensor 1
5	Original Width Sensor 5		

Size (W x L)	Width Sensor					Length Sensor			
	1	2	3	4	5	A4Y LTY	B5	A4	LG
A3 (297x420)	ON	ON	ON	ON	ON	ON	ON	ON	ON
B4 (257x364)	ON	ON	ON	—	—	ON	ON	ON	ON
A4 SEF (210 x 297)	ON	ON	—	—	—	ON	ON	ON	—
A4 LEF (297 x 210)	ON	ON	ON	ON	ON	—	—	—	—
B5 SEF (182 x 257)	ON	—	—	—	—	ON	ON	—	—
B5 LEF (257 x 182)	ON	ON	—	—	—	—	—	—	—
B6 SEF (128 x 182)									
B6 LEF (182 x 128)	ON								
11" x 17" SEF (DLT)	ON	ON	ON	ON	—	ON	ON	ON	ON
11" x 15" SEF	ON	ON	ON	ON	—	ON	ON	ON	ON
8 2/1" x 11" SEF (LT)	ON	ON	—	—	—	ON	ON	—	—
11" x 8 1/2" LEF (LT)	ON	ON	ON	ON	—	—	—	—	—

\*The machine cannot tell the difference between certain original sizes, such as DLT (11 x 17") and 11 x 15". The machine assumes such originals are 11 x 17". To change this, use SP 6016-001.

### 1.2.7 ORIGINAL FEED PROCEDURE

When the machine signals the ADF to start feeding, the feed motor drives the pick-up roller, the paper feed belt, and the separation roller, and these rollers feed the original. To correct skew, the original bumps into the entrance roller.

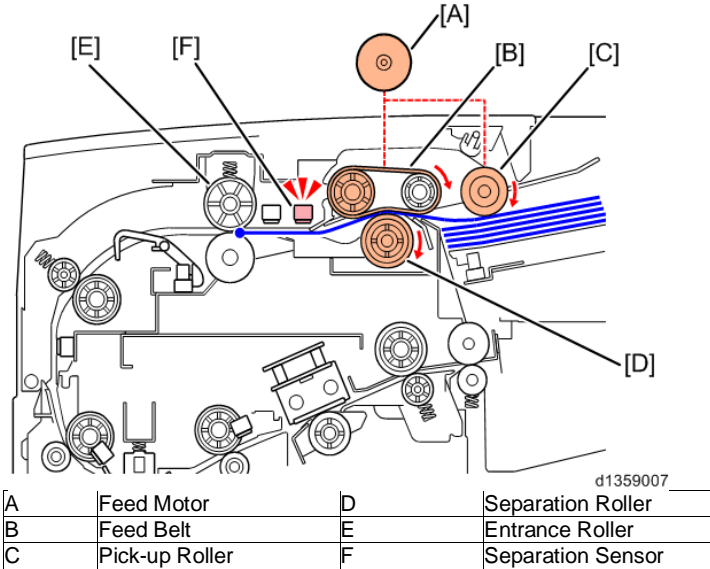

After skew correction at the entrance roller, the entrance motor [G] and the relay motor [H] (relay roller [I]) feed the original towards the exposure glass.

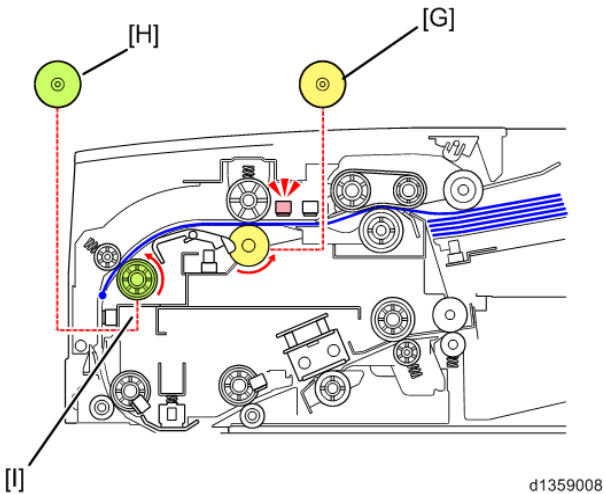

When the interval sensor [M] detects the original, the transport motor [K] drives the pre-scanning roller and the white roller [J] in order to pass the original through the scanning area. (L: Registration Sensor)

After the entrance roller starts to rotate, the feed motor drives faster to make the space smaller

between the former sheet (on the scanner) and the next sheet. However, if the sheet reaches the pre-scanning roller at this speed, original buckle may occur due to the disparity of roller rotation speeds. So when the skew correction sensor detects the leading edge, original transport speed slows down so that the roller speeds match when the leading edge of the original reaches the pre-scanning roller.

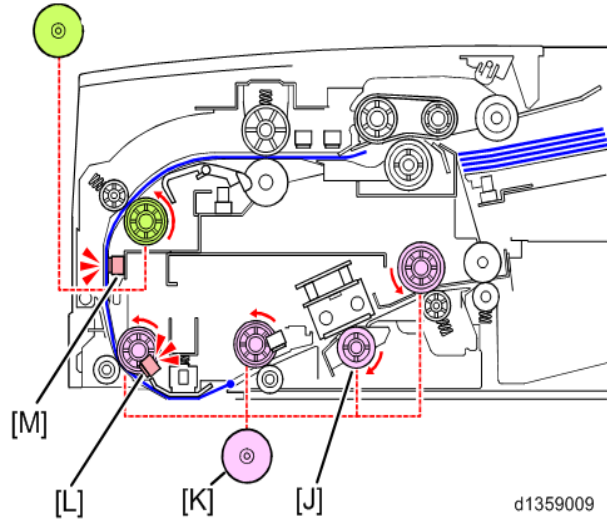

The exit motor [P] drives the exit roller [O] to send paper out to the exit tray when the exit sensor [Q] detects the original.

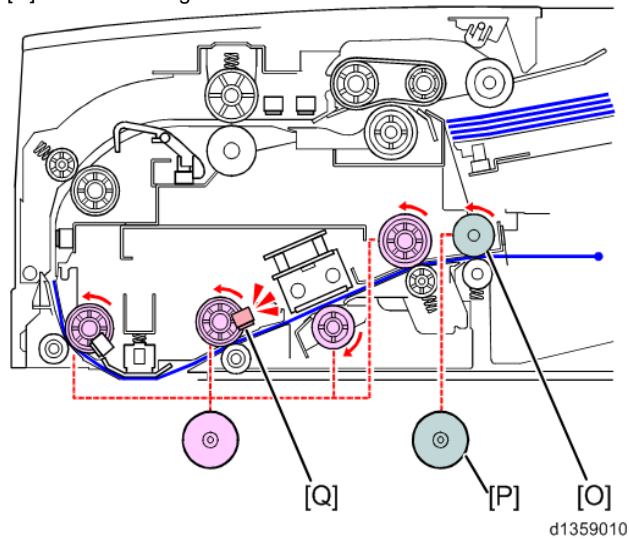

### 1.2.8 DUPLEX SCANNING

A CIS (Contact Image Sensor) [A] enables the machine to scan both faces of an original at once.

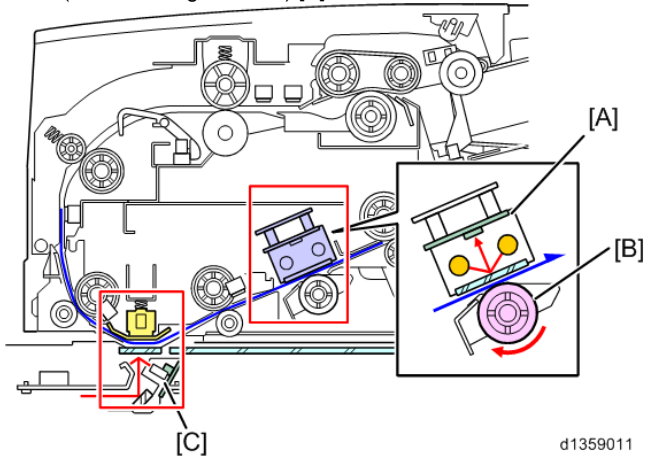

- A: CIS
- B: White Roller
- C: Scanner Unit (LED)

### 1.2.9 JAM DETECTION

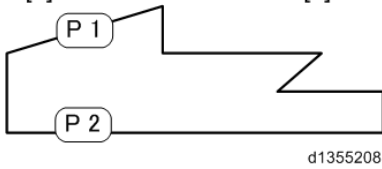
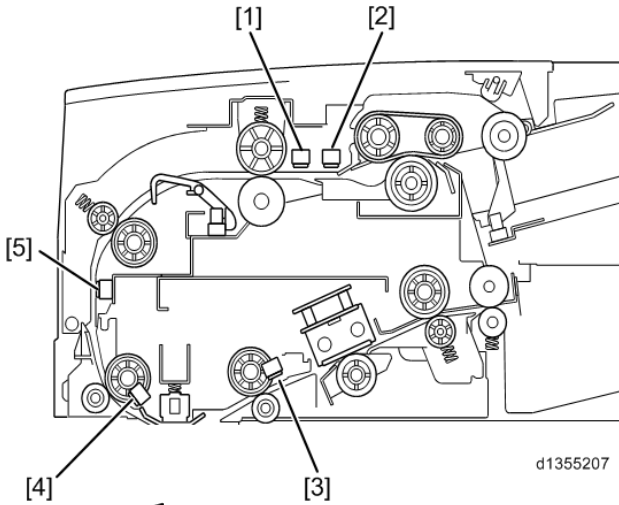

1	Skew Correction Sensor	4	Registration Sensor
2	Separation Sensor	5	Interval Sensor
3	Exit Sensor		

In jam detection, the following sensors below are used. And the detection trigger are as shown in the list below;

Jam Display	Jam Name	Detection Trigger
P1	Separation Sensor Unreach Jam	The leading edge cannot be detected even when original is transported 224 mm after separation starts
P1	Skew Correction Sensor Unreach Jam	The leading edge cannot be detected even when original is transported 46 mm after the separation sensor detects the leading edge
P1	Interval Sensor Unreach Jam	The leading edge cannot be detected even when original is transported 172 mm after skew correction starts
P1	Registration Sensor Unreach Jam	The leading edge cannot be detected even when original is transported 96 mm after the interval sensor detects the leading edge
P2	Exit Sensor Unreach Jam	The leading edge cannot be detected even when original is transported 130 mm after the registration sensor detects the leading edge
P1	Separation Sensor Stagnation Jam	The trailing edge cannot be detected even when original is transported xxx mm (the number comes out from the below equation) after the skew

Details

Jam Display	Jam Name	Detection Trigger				
		correction starts. Equation: ( <b>“Standard Value”-35.3</b> ) x 1.5 See the list below about “Standard Value”;				
		A4 / LT Sensor	Length Sensor 1	Length Sensor 2	Length Sensor 3	Standard Value
		Not detect	Not detect	Not detect	Not detect	226.8
		detect	Not deectct	Not detect	Not detect	253.8
		-	detect	Not detect	Not detect	291
		-	-	detect	Not detect	320
		-	-	-	detect	432
		*In case that user designates the length of original which is larger than “Standard Value”, Consider the designated length as “Standard Value”.				
P1	Skew Correction Sensor Stagnation Jam	The trailing edge cannot be detected even when original is transported 46 mm after the separation sensor detects the trailing edge.				
P1	Interval Sensor Stagnation Jam	The trailing edge cannot be detected even when original is transported 82 mm after the relay motor stops.				
P2	Registration Sensor Stagnation Jam	The trailing edge cannot be detected even when original is transported 93 mm after the interval sensor detects the trailing edge.				
P2	Exit Sensor Stagnation Jam	The trailing edge cannot be detected even when original is transported 130 mm after the registration sensor detects the trailing edge.				

## 1.2.10 ABNORMAL DETECTION

No.	Abnormal Name	To Release	Possible Trigger
700-01 (*)	Bottom Plate Lift Motor Abnormal (1-Path ADF)	Reboot the machine	<ul style="list-style-type: none"> <li>▪ Bottom plate sensor abnormal (output abnormal)</li> <li>▪ Bottom plate HP sensor abnormal (output abnormal)</li> <li>▪ Bottom plate motor abnormal (cannot drive)</li> <li>▪ Controller board defection</li> </ul>
700-02 (*)	Original Pick-up Abnormal (1-Path ADF)	Reboot the machine	<ul style="list-style-type: none"> <li>▪ Pick-up HP sensor abnormal (output abnormal)</li> <li>▪ Pick-up HP motor abnormal (cannot drive)</li> <li>▪ Controller board defection</li> </ul>
700-04 (*)	Feed Motor Abnormal (1-Path ADF)	Reboot the machine	<ul style="list-style-type: none"> <li>▪ Motor defection</li> <li>▪ Connector unconnected</li> <li>▪ Harness disconnection</li> <li>▪ Overload state</li> </ul>
700-05 (*)	Skew Correction Motor Abnormal (1-Path ADF)	Reboot the machine	<ul style="list-style-type: none"> <li>▪ Motor defection</li> <li>▪ Connector unconnected</li> <li>▪ Harness disconnection</li> <li>▪ Overload state</li> </ul>
700-06 (*)	Relay Motor Abnormal (1-Path ADF)	Reboot the machine	<ul style="list-style-type: none"> <li>▪ Motor defection</li> <li>▪ Connector unconnected</li> <li>▪ Harness disconnection</li> <li>▪ Overload state</li> </ul>
700-07 (*)	Scanning Motor Abnormal (1-Path ADF)	Reboot the machine	<ul style="list-style-type: none"> <li>▪ Motor defection</li> <li>▪ Connector unconnected</li> <li>▪ Harness disconnection</li> <li>▪ Overload state</li> </ul>
700-09 (*)	Exit Motor Abnormal (1-Path ADF)	Reboot the machine	<ul style="list-style-type: none"> <li>▪ Motor defection</li> <li>▪ Connector unconnected</li> <li>▪ Harness disconnection</li> <li>▪ Overload state</li> </ul>
701-02	Original Pick-up Driver Abnormal (1-Path ADF)	Reboot the machine	Motor drive IC abnormal
702-04	Protection-device Disconnection Abnormal 4 (1-Path ADF)	Reboot the machine	In a non-interlock electrical part, motor defection or harness short
702-05	Protection-device Disconnection Abnormal 5 (1-Path ADF)	Reboot the machine	In an interlock electrical part, motor defection or harness short
185-00 (*)	CIS Communication Error (1-Path ADF)	Reboot the machine	<ul style="list-style-type: none"> <li>▪ Communication harness abnormal between DF board and CIS board</li> <li>▪ ASIC abnormal in CIS</li> <li>▪ ASIC boot operation abnormal in CIS</li> </ul>
186-00 (*)	CIS Light-source Abnormal (1-Path ADF)	Reboot the machine	<ul style="list-style-type: none"> <li>▪ <b>[When initial execution]</b></li> <li>▪ One or both defection of two CIS LEDs</li> <li>▪ <b>[When original transport]</b></li> <li>▪ One or both defection of two CIS LEDs</li> <li>▪ ADF main controller board defection</li> </ul>
187-00	CIS Black-level	Reboot the	CIS device defection

Details

No.	Abnormal Name	To Release	Possible Trigger
(*)	Abnormal (1-Path ADF)	machine	
188-00 (*)	CIS White-level Abnormal (1-Path ADF)	Reboot the machine	<ul style="list-style-type: none"> <li>▪ CIS device defection</li> <li>▪ CIS background or white roller blemish / taint / wrong installation</li> </ul>
189-00	CIS Gray-balance Adjustment Abnormal (1-Path ADF)	Reboot the machine	<ul style="list-style-type: none"> <li>▪ CIS device defection</li> <li>▪ Adjustment chart blemish / taint degradation</li> </ul>

\*Two times occurrence in a row issues an initial jam notice. But more than three times occurrence in a row issues an abnormal code notice

## 2. DRAWER UNIT

### 2.1 OVERVIEW

This machine doesn't have a front cover like the existing machines have. By inserting your hand into the grip to pull the drawer out, you can access the inner units of the machine. This machine has a lock mechanism that prevents ripping paper when the drawer is pulled out.

#### 2.1.1 COMPONENTS

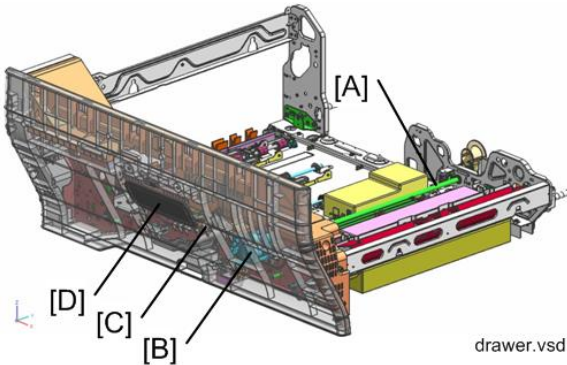

drawer.vsd

	Name
A	Drawer Lock Shaft
B	Drawer Lock Motor
C	Drawer flapper Sensor
D	Flapper

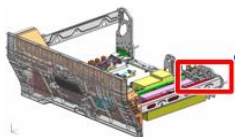
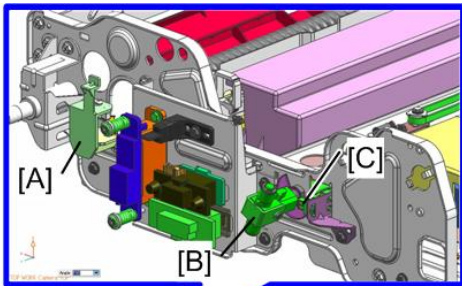

drawer1.vsd

	Name
A	Curled Cord Guide
B	Drawer Lock Shaft (End)
C	Drawer Lock Sensor

## 2.2 DETAILS

### 2.2.1 LOCK MECHANISM

This machine performs drawer lock/PTR control automatically and allows the locked drawer to open when it is necessary, in order to let user open doors in the correct order, not to rip jammed paper out.

#### ◆ When Lock is released?

- When the flapper [A] is pushed in and the flapper sensor [B] detects it.
- When a jam has occurred (except for a jam where paper will be torn if the drawer unit is opened) and the LED on the drawer blinks.
- When power off / sleep mode.
- When the right cover is open.

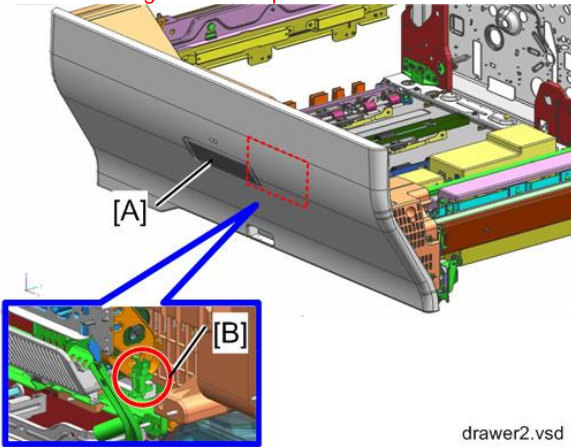

#### ◆ Lock Release Operation

5. The drawer unit lock motor [A] drives to rotate the drawer lock shaft by whose end the drawer is locked.

drawer3.vsd

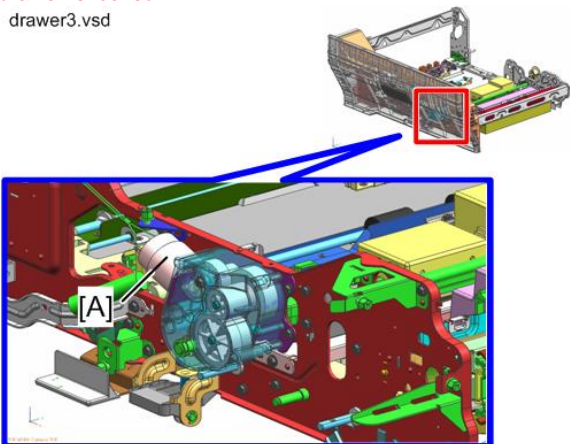

6. The drawer lock shaft [A] rotates CCW.

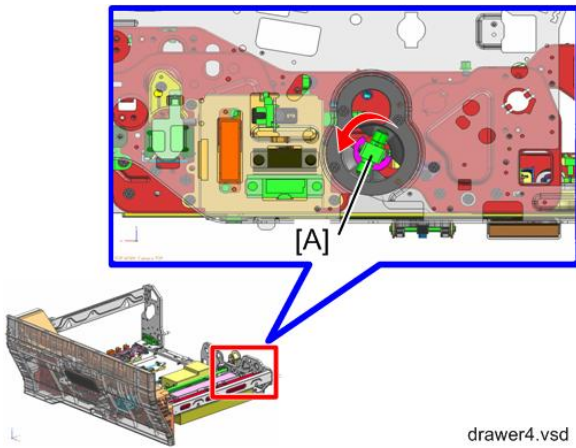

7. The drawer lock sensor [B] detects the edge of the actuator [A] attached on the drawer lock shaft when the drawer lock shaft comes off the latch completely. Then the drawer unit lock motor stops.

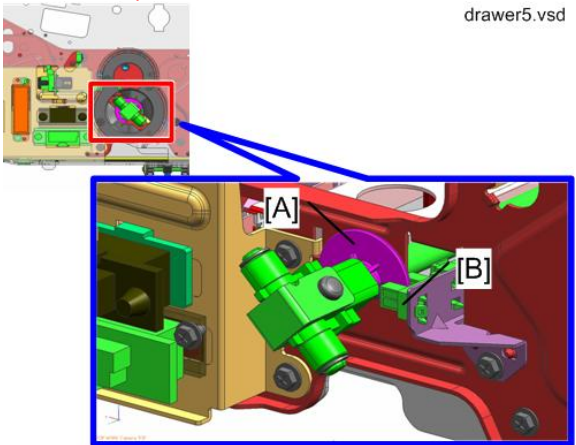

◆ **Lock Operation**

1. The drawer is pushed in completely.

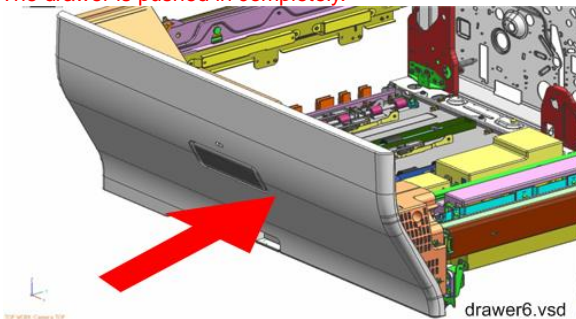

2. The drawer set sensor [A] detects it (the tab [B] on the rear of the drawer).

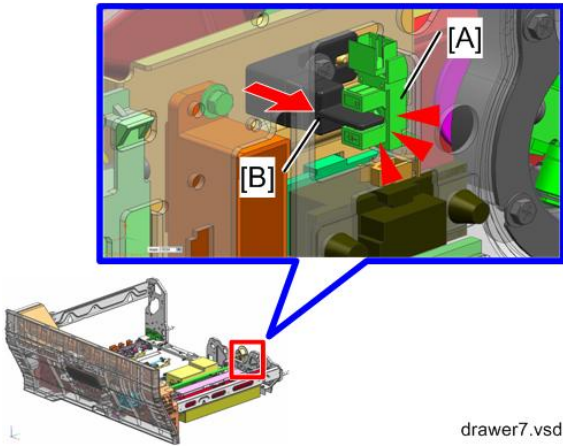

drawer7.vsd

The placement judge is affected by the following things: Drawer set sensor / Drawer interlock switch / Fusing drawer connector / Heating roller push switch

3. The drawer unit lock motor [A] turns on.

drawer3.vsd

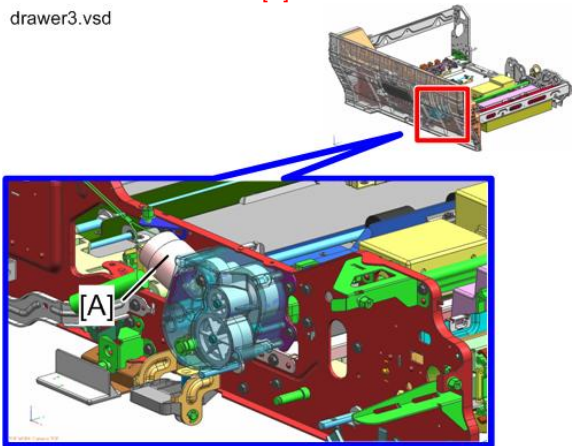

4. The drawer lock shaft [A] starts to rotate CCW (viewed from the rear of the machine)

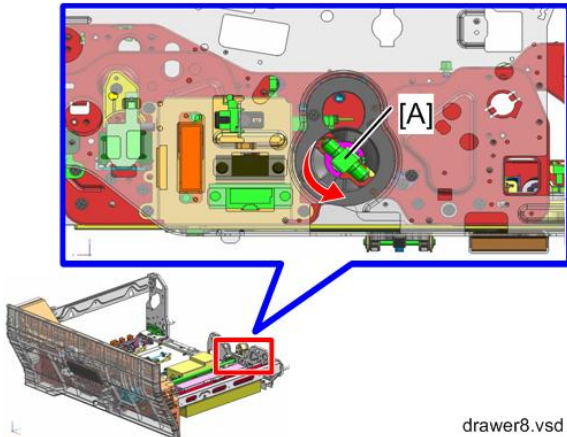

5. The actuator [A] of the drawer lock actuator rotates and the drawer lock sensor [B] detects the edge of the actuator [A], when the drawer lock shaft [C] latches on. Then the drawer unit lock motor stops.

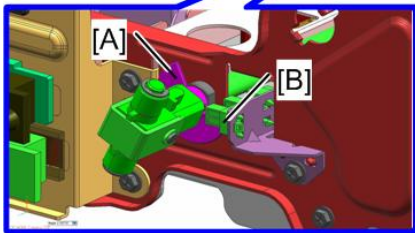
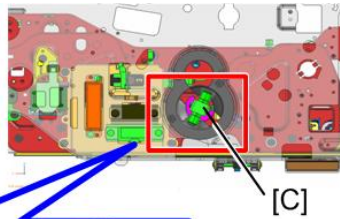

◆ **Drawer Unit State List**

There are three states of the drawer unit. The state of the unit varies depending on the machine state.

1. Not withdrawable

Machine State	Remarks
Output	Including application output / fax output at night
Correcting /Adjusting Operation	Warming-up, Process Control, MUSIC, Toner Recovery, Web Cleaning
Forced Power off	Forced shutdown due to blackout / disconnection, or press and hold the power button
SC Issued	SC670 / SC672 occurs
*Straddling Jam	The drawer can be withdrawn after jammed paper is removed from

Comment [ n 6]: 3/6 updated

Machine State		Remarks
		vertical transport / bypass unit / purge unit.
Defective Any Drawer Lock-related Parts	Cannot release the drawer lock correctly. SC525 occurs due to an problem with the drawer unit lock motor or the PTR release motor.	To solve this problem, you need to remove some covers and the drawer unit lock motor to release the lock manually. (For details, see the Main Service Manual "Drawer Unit > If the Drawer is Locked")
DUB / TSB Abnormal	SC626 occurs	

\*In case of jam (such as listed jams below) that straddles the drawer unit and other unit, jammed paper will be torn if you pull out the drawer unit, and torn paper may remain in the machine.

- Jam between the bypass unit and the registration unit
- Jam between the relay unit and the vertical transport
- Jam between the paper exit and the purge unit

So in this machine, the drawer unit is locked when a straddling jam occurs.  
By following the directions on the display, the drawer can be withdrawn after you remove jammed paper from the vertical transport / the bypass unit / the purge unit.

2. Withdrawable 2 sec. after you put your hand into the flapper  
The release operation of the drawer lock starts when you put your hand into the flapper.  
Be sure to wait 2 sec. and then pull the drawer out.

Machine State		Remarks
Ready	Low Power Mode	
Door / Cover Open	Cover or door opens	Any of the following cover / door opens: Upper Front Cover / Purge Door / Paper Feed Tray
Downtime	<ol style="list-style-type: none"> <li>1. SC that is listed below occurs: <ul style="list-style-type: none"> <li>▪ SC670</li> <li>▪ SC872</li> <li>▪ SC525</li> </ul> </li> <li>2. When the used toner collection bottle is full / for replacement of the toner bottle</li> </ol>	
Low Power	Energy Saving Mode	

3. Withdrawable immediately  
In cases that apply to neither "1" nor "2" mentioned above.  
\*By executing SP1-040-001, you can unlock the drawer.

### 2.2.2 ELECTRICAL SUPPLY

In this machine, the drawer unit has the curled cord [B] from which the drawer unit earns electrical power. The curly cord guide [A] holds the curled cord [B] when the drawer is pulled out and the curly cord [B] is stretched.

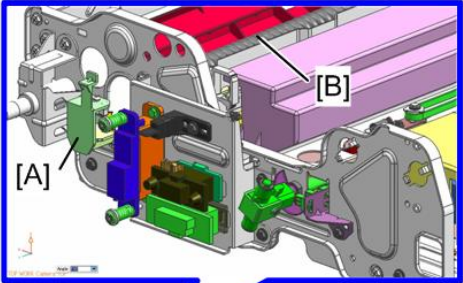

drawer10.vsd

### 3. TONER SUPPLY

#### 3.1 MECHANISM DESCRIPTIONS

##### 3.1.1 OVERVIEW

\*The diagram below is the Office type

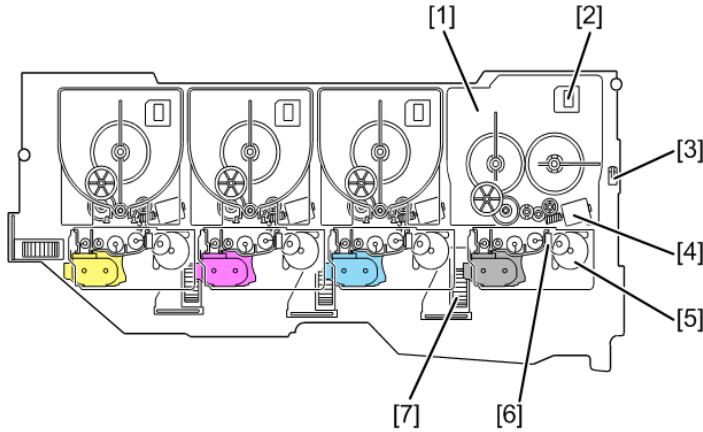

d1359301

- |                                |                           |
|--------------------------------|---------------------------|
| 1. Toner Cartridge             | 5. Sub Hopper Drive Motor |
| 2. ID Chip                     | 6. Toner End Sensor       |
| 3. Interlock SW                | 7. Development Intake Fan |
| 4. Toner Cartridge Drive Motor |                           |

◆ **Difference between the Office and the Pro**

One of the differences is the configuration of both toner supply units as shown:

[A]: Office

[B]: Pro

[A]

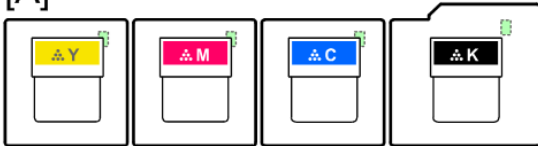

[B]

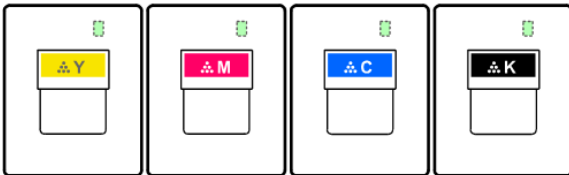

d1359307e

The other difference is the number of the unit's agitator in black. The office has two agitators

while the pro has one agitator as shown below:

[A]: Office

[B]: Pro

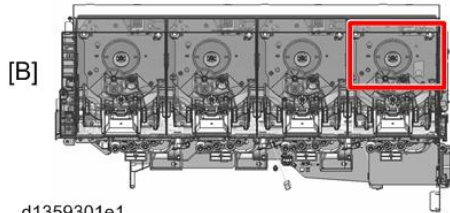
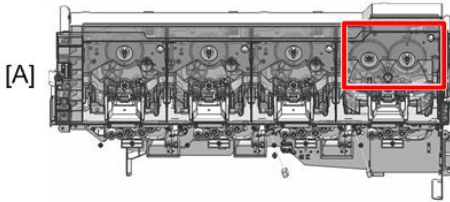

d1359301e1

◆ **Anti-misplacement Bottle Configuration**

To prevent placing a wrong color bottle to a wrong place, each bottle differs in its back configuration. Arrows in the picture below suggest which part of a bottle is different from the other bottles. (The picture shows Office type machine).

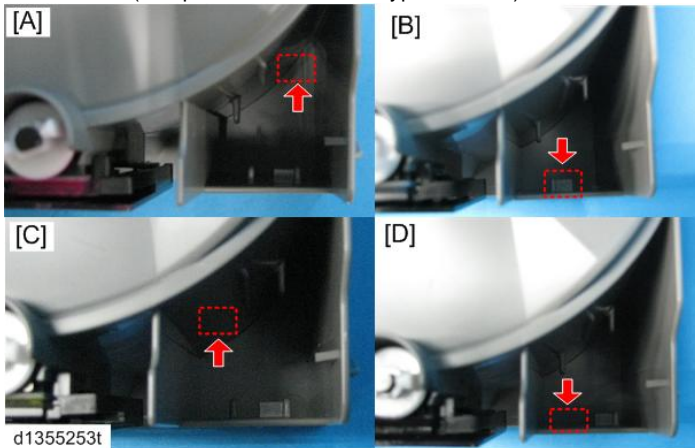

d1355253t

[A]: magenta

[B]: cyan

[C]: yellow

[D]: black

## 3.2 MECHANISM DETAILS

### Mechanism Overview

Mechanism	Related Part / Method
Cartridge Drive	Agitator and coil driven by cartridge drive motor
Sub Hopper	Sub hopper coil transport method
Sub Hopper Drive	Individual STP motor for each color
Toner Transport	Transport coil transporting toner to development unit
Toner Supply	Controlled with toner density sensor and counter for pixel attached amount
Cartridge Information Retention / Cartridge Identification	Information retention of toner bottle, with ID chip

### 3.2.1 TONER FILLING

Toner filling means sending toner from the toner cartridge to the sub hopper. Here are explanations of the toner filling mechanisms.

#### 1. Toner Cartridge Drive

When a toner cartridge [A] is placed, the shutter [C] on the cartridge opens and then the toner transport port [B] also opens. When a toner cartridge [A] is removed, the shutter [C] on the cartridge closes and the toner transport port [B] also closes. Each color cartridge has a cartridge drive motor that drives an agitator and toner transport screws.

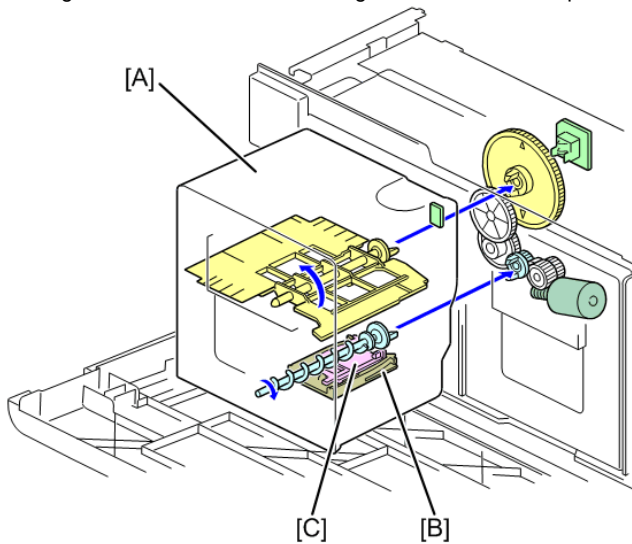

d1359302

Each cartridge has a cartridge drive motor [D] that drives the agitator [E] and toner transport coils [F].

**Comment [オブライエンア]:** 'tap' – this name seems a bit strange

RE:

In Japanese, this word is “トナー供給口”. I re-think and “Toner supply port” might be suit. But I cannot judge whether this is truly natural or not in English. 12/6

I think 'toner supply port' is more normal for us– I never saw 'toner supply tap'

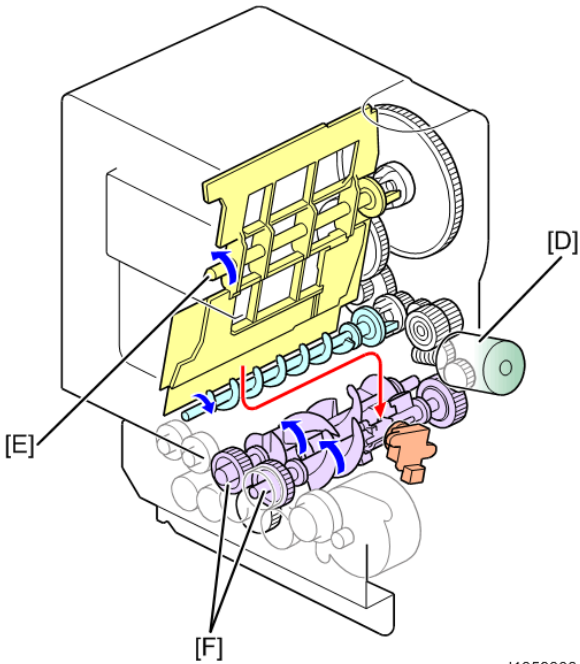

d1359303

**2. Sub Hopper**

The sub hopper includes 4 transport coils [A] (larger 2 / smaller 2)

The larger coils agitate toner and the smaller coils transport toner to the downstream part of the sub hopper.

The downstream part of the sub hopper is a toner transport path for supplying the development unit with toner.

If the toner end sensor (in the sub hopper) detects a toner shortage in the hopper, the toner cartridge supplies toner to the sub hopper.

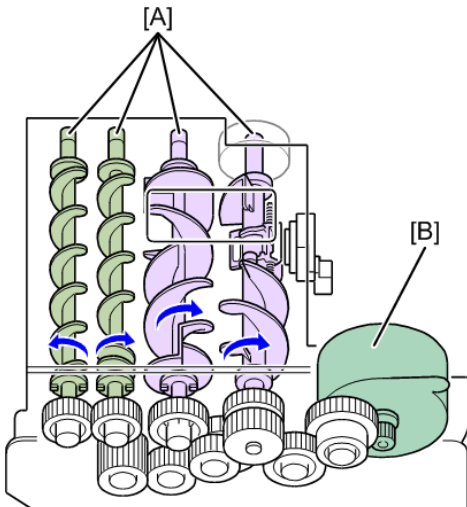

d1359304

### 3. Toner Filling Timing

Toner filling takes place only when ID chip / interlock turn on.

#### <Sensor states and toner filling operations when a toner bottle is replaced>

Bottle Replacement Procedure	ID Chip	Interlock	Supply Operation
Bottle is placed	ON	ON	○Drive
Bottle replacement Starts	ON	OFF	×Not drive
After bottle is removed (No bottle is placed)	OFF	OFF	×Not drive
During a bottle replacement	OFF -->ON	OFF	×Not drive
Replacement is completed	ON	ON	○Drive

## 3.2.2 TONER SUPPLY

Toner supply means sending toner from the sub hopper to the development unit. Here are explanations about toner supply mechanisms.

### 1. Sub Hopper Drive

For each color, a stepping motor [A] controls toner supply to the development unit. When the toner density sensor in the development unit detects that toner is needed, the sub hopper drive turns on.

The two upstream transport screws [B] drive and agitate toner that arrives from the toner cartridge.

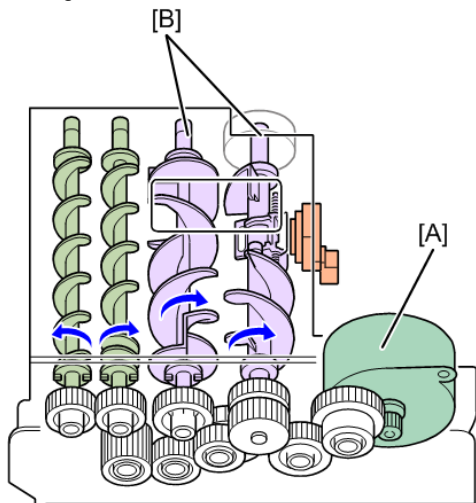

d1355128

### 2. Toner Transport / Supply

There are four transport coils in the sub hopper.

Toner from the cartridge is sent to the upstream transport coils [A] that agitate toner. Between the upstream coils [A] and downstream coils [B], there is an open port [C] from which toner moves to the downstream coils.

The downstream transport coils [B] don't agitate toner but send it to the development unit through the supply port [D] for the development unit.

The upstream transport coils and the downstream transport coils differ in their blade pitch. The

**Comment [オブライエン8]:** Upper, lower – I don't think we can say that – they seem at the same level, looking at the diagrams in this section

RE:

I re-read the original and find that maybe "upstream" and "downstream" are suitable to put in.

There are same mistakes in other parts so I collected.

12/10

upstream coils [A] have a larger pitch to agitate toner easily. The downstream coils [B] have a smaller pitch so as not to supply too much toner at one time; this also means that even when the toner end sensor detects toner end, there is more toner held in the bottom of the sub hopper than if the coils were larger. This means that even when the toner bottle becomes empty, toner auto-supply from the sub hopper continues, and you can replace toner bottles even during operation, which leads to reduced downtime. 400-sheet copy is available from the near-end in A4/5% chart.

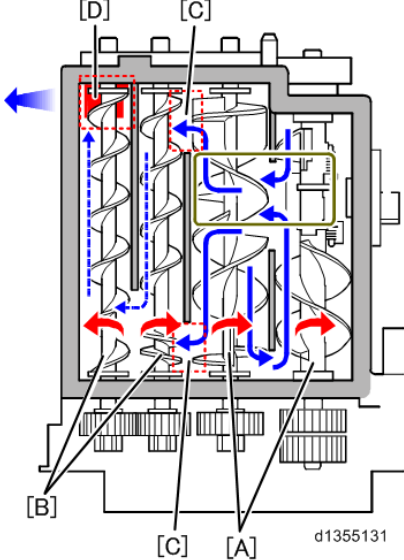

### 3.2.3 TONER END / NEAR-END CONTROL

There four remaining-toner states in this machine. This is almost the same as for the ProC751EX series. The big difference from the former model (MPC7501/6501) is whether replacement is possible during operation.

Remaining-toner State	Descriptions
1. Sufficient Toner	Sufficient toner exists in the toner cartridge. The amount is estimated from the pixel count.
2. Pre Toner Near-end	Remaining toner (%) in the bottle is X (X can be set in "SP3110-011 ~ 014" / Default: 10). *Default is "function on" (Switch on/off in SP3110-001 [0:ON / 1:OFF]). *This function enables an earlier notification before replacement is needed. **"Toner runs out soon. Prepare a toner bottle for replacement." will be shown as a banner message.
3. Toner Near-end	Remaining toner (%) in the bottle is zero. *Toner remains only in the sub hopper. **"The toner bottle is empty. The machine will soon stop printing. Replace toner bottles" is displayed as a banner message, and you can replace the cartridge while in operation.
4. Toner End	Toner in the sub hopper has run out (zero) and printing isn't available. *The machine stops and shows toner replacement call pop-up on its display.

Here is a flow diagram of toner end / near-end state with explanations.

	Flow Diagram	Remarks
1. Toner Full	<pre> graph TD     START([START]) --&gt; Process1[Print-image amount / toner consumption suggests the remaining amount (%) of toner]     Process1 --&gt; Decision{Remaining toner(%) &lt; Threshold}     Decision --&gt; Process2[The state of toner amount changes to [Pre Toner Near-end]]     Process2 --&gt; END([END])                     </pre> <p style="text-align: right;">Pretoner.vsd</p>	
2. Pre Toner Near-end		<ul style="list-style-type: none"> <li>▪ Prerequisite: Toner full</li> <li>▪ Switch enabled/disabled In SP3110-001 [0:ON / 1:OFF]</li> <li>▪ Set the threshold in SP3110-011~014 [Default: 10]</li> </ul>

	Flow Diagram	Remarks
<p>3. Toner Near-end</p>	<pre> graph TD     Start([Start]) --&gt; D1{The toner end sensor detects a no full state of the sub hopper.}     D1 --&gt; P1[No full state is counted]     P1 --&gt; D2{No full state times &lt; Threshold}     D2 -- Yes --&gt; P2[The state of toner amount changes to [Toner Near-end]]     P2 --&gt; End1([End])     D2 -- No --&gt; P3[Toner supply to the sub hopper]     P3 --&gt; D1             </pre> <p style="text-align: right;">near-end.vsd</p>	<ul style="list-style-type: none"> <li>▪ Prerequisite: Toner full / Pre toner near-end</li> <li>▪ The toner end sensor monitors the sub hopper but not the toner bottle.</li> <li>▪ The threshold of consecutive "Toner run out" detection is 30 (SP3120-001)</li> </ul>
<p>4. Toner End</p>	<pre> graph TD     Start([Start]) --&gt; P1[Check the counters for pages / printing-image]     P1 --&gt; D1{Either counter &lt; Threshold}     D1 --&gt; P2[The state of toner amount changes to [Toner End]]     P2 --&gt; End1([End])             </pre> <p style="text-align: right;">toner-end.vsd</p>	<ul style="list-style-type: none"> <li>▪ Prerequisite: Toner Near-end</li> </ul>

400 sheets (A4/5% chart) can be printed after toner near end occurs.

### 3.2.4 BOTTLE INFORMATION STORE / BOTTLE LOCK DETECTION

The toner cartridge has an ID chip [A] by which toner cartridge information is stored. ID chip information is read at the terminal [B].  
The ID chip helps to detect cartridge placement. ID chip information includes the amount of toner filling, which is used to control toner end detection. The information also includes which factory produced the toner, toner type, and toner color.

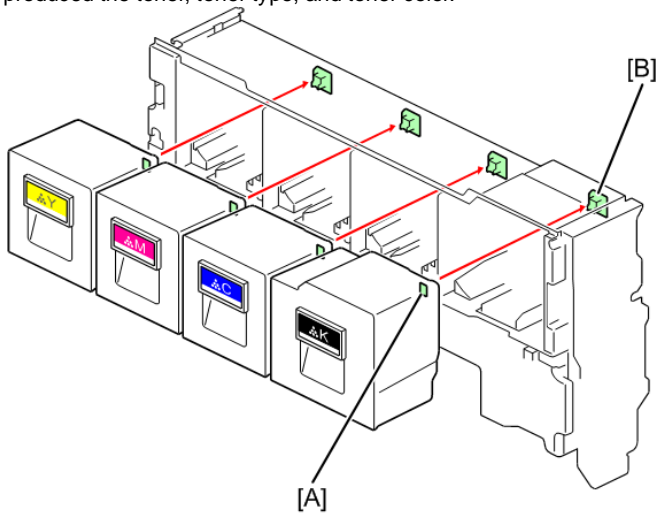

d1359306

## 4. SCANNER

### 4.1 MAIN COMPONENTS

#### 4.1.1 OVERVIEW

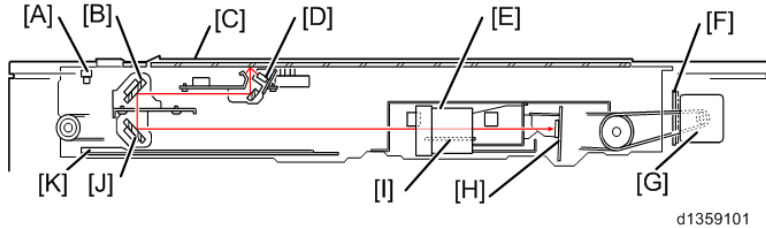

A	Scanner HP Sensor
B	2nd Mirror
C	Exposure Glass
D	1st Mirror
E	Lens
F	SIO
G	Scanner Motor
H	SBU
I	IDB
J	3rd Mirror
K	Anti-Condensation Heater (optional)

#### 4.1.2 COMPONENTS

Scanner	LED
	SBU (3-line CCD, Resolution: 600dpi)
Drive	Scanner Motor (Biphase Stepping Motor)
	Drive Wire
Original Size Detection	Scanner HP Sensor
	APS (Length Sensor x2)
Others	Anti-Condensation Heater (Service Optional)

## 4.2 MECHANISM DETAILS

### 4.2.1 SCANNER

An LED lamp [A] is used as a light source in this scanner. An LED lamp saves energy and is superior in the characteristic of light start-up so this machine employs not a xenon lamp but a LED lamp. Light from the lamp passes to the CCD through the following route:

1st Mirror > 2nd Mirror > 3rd Mirror > Lens Block > CCD

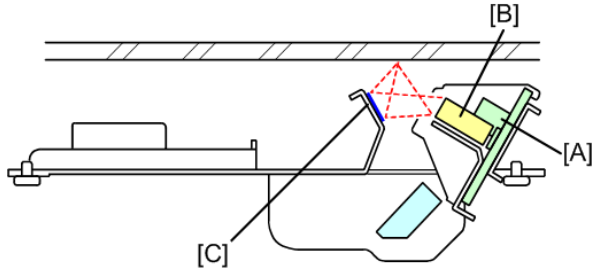

A	LED Lamp
B	Light Guide Plate
C	Reflector

- **LED Lamp**  
LED saves energy and provides better light at start-up so this machine employs not a xenon lamp but a LED lamp.
- **CCD**  
The CCD collects the light that was reflected from the original and converts it to three color analog signals (R, G, B).  
The resolution of this CCD is 600dpi.
- **Shading Adjustment**  
A white plate for shading adjustment is attached to the back of the scale. Just after the power switch is turned on, the machine performs shading adjustment, during which the scanner unit moves to the white plate to emit LED light onto it in order to perform lamp modulation.  
For normal (book mode) scanning, the machine performs shading every page regardless of BW or color.  
For ADF scanning, the machine performs shading before the 1st sheet of the original is scanned regardless of BW or color, and then after that the machine performs shading for following sheets at regular intervals (one minute or more).

## 4.2.2 DRIVE

The scanner unit is driven with scanner wires [D] which are driven by the scanner motor [E]. Scanning is done with one run from left to right regardless of what mode it is. Scanner location control (for the 1st carriage [A]) refers to the scanner HP sensor [B] as a criterion. The scanner HP sensor is near the scan area of the sheet-through DF.

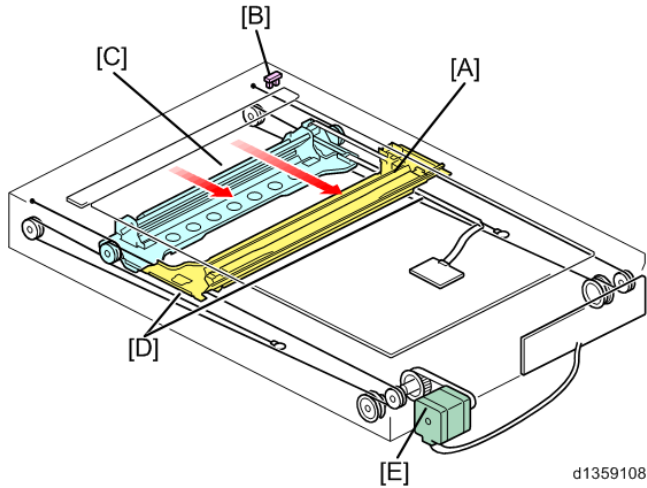

d1359108

A	1st Carriage
B	Scanner HP Sensor
C	2nd Carriage
D	Scanner Wire
E	Scanner Motor

### 4.2.3 ORIGINAL SIZE DETECTION

Two reflective sensors [B] are used as length detectors. Width direction is detected by a 3-point pre-scan using the CCD.

The platen open/close sensor [A] is used to detect when original size determination is done. When the sensor state changes from “not interrupted” to “interrupted”, the length is determined and pre-scan starts at the same time. When the sensor state stays “not interrupted”, the machine uses detection data that is read just after the [Start] key is pressed.

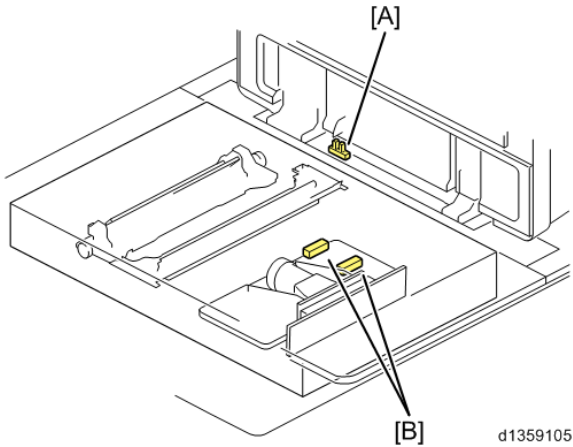

A	Platen open/close sensor (APS)
B	Original Sensor (length)

### 4.2.4 SENSOR STATE

Sensor states depending on original size can be seen with “SP4301-001”.

The display in “SP4301-001” varies as shown below.

Smaller paper than B5 cannot be detected because of the location of the sensors; the display shows “00000000” for all these sizes.

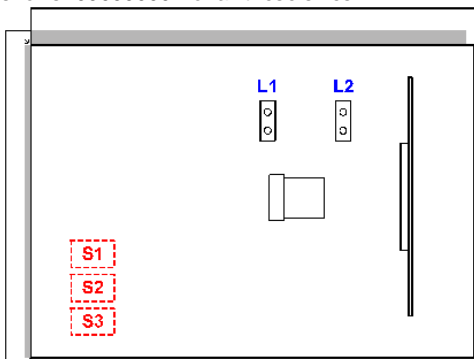

Size	L1	Display in SP4301-001
A3	○	00000011
B4	○	00000011

Size	L1	Display in SP4301-001
A4: LEF	o	00000001
A4: SEF	-	00000000
B5: LEF	o	00000001
B5: SEF	-	00000010
A5: LEF	-	00000000
A5: SEF	-	00000000

For width direction, if the value detected by the CCD at any of the three detection locations (S1, S2, or S3) is 18 or more, the machine detects that an original has been placed. SP 4-310-1 to 9 show the CCD readings at S1 to S3. The values shown are the latest detection results.

SP4310-001: S1 point: R-value at CCD original size detection	If any of the values is more than 18, an original exists at the S1 point
SP4310-002: S1 point: G-value at CCD original size detection	
SP4310-003: S1 point: B-value at CCD original size detection	
SP4310-004: S2 point: R-value at CCD original size detection	If any of the values is more than "18", an original exists at the S2 point
SP4310-005: S2 point: R-value at CCD original size detection	
SP4310-006: S2 point: B-value at CCD original size detection	
SP4310-007: S3 point: R-value at CCD original size detection	If any of the values is more than "18", an original exists at the S3 point
SP4310-008: S3 point: G-value at CCD original size detection	
SP4-310-009: S3 point: B-value at CCD original size detection	

Size Name	Feed Direction	Size (Width x Length)	S1	S2	S3
A3	LEF	297 x 420			o
B4	LEF	257 x 364		o	-
A4	LEF	210 x 297	o	-	-
A4	SEF	297 x 210			o
B5	LEF	182 x 257	-	-	-
B5	SEF	257 x 182		o	-
A5	LEF	148 x 210		-	-
A5	SEF	210 x 148	o	-	-
B6	LEF	128 x 182	-	-	-
B6	SEF	182 x 128	-	-	-

### 4.2.5 ORIGINAL TRANSPORT FROM ADF

There is a difference between MPC8002SP / 6502SP and C5110S / C5100S in the method of original transport from the ADF.

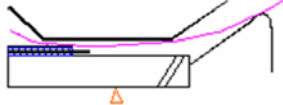
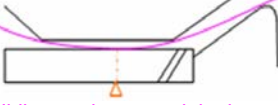
	MPC8002SP / 6502SP	C5110S / C5100S
<b>Transport Method</b>	Non-contact Transport	Contact Transport
<b>Descriptions</b>	 <p>With the film attached on the glass, an original doesn't contact the glass.</p>	 <p>While passing, an original contacts the glass.</p>
<b>Merit</b>	It hardly causes stripe tainted image due to an original that has foreign substances on its face and taints the surface of the glass.	It hardly causes stripe tainted image due to dust on the glass, because the glass is cleaned by contacting a transported original.
<b>Demerit</b>	Comparing to the contact method, due to dust that exists in the path, stripe tainted image occurs more often.	More often than in the non-contact method, stripe tainted image occurs due to foreign substances that attaches on the surface of an original and taints the glass.
<b>Aim</b>	To improve prevention against the occurrence of stripe tainted image due to sticky foreign substances.	Comparing to user of machines for office, less user of this machine tends to use an original that has sticky substances on its surface. And considering to main user of this machine, it's important to improve a prevention against stripe tainted image due to dust in the path
<b>Note</b>	<ol style="list-style-type: none"> <li>4. Be sure to replace the sheet-through glass with the film attached on the glass.</li> <li>5. When you attach the film on the glass, you need to keep the left scale attached on the glass in order to decide the location of the film.*1</li> <li>6. You can change the method (contact method to non-contact, or vice versa) by replacing the parts.*1</li> </ol>	-

\*1: For details, see the replacement & adjustment in the SM.

**Comment [n 9]: 2/1**  
Translated the flow chart

### 4.2.6 DUST DETECTION

- General**  
 After an original is placed in the ADF and the [Start] key is pressed, dust detection starts. The machine checks for dust on the ADF exposure glass before the first original of a job is fed by the ADF.  
 The operation flow varies depending on the SP mode setting.
- Related SP codes**  
 SP4020-001: DF dust detection setting / Detection on/off setting (default "0" = "off")  
 SP4020-002: DF dust detection setting / Detection level switch setting  
 SP4020-003: DF dust detection setting / Adjustment level switch setting  
 SP7852-001: DF contact glass / Dust detection counter  
 SP7852-002: DF contact glass / Dust clear counter

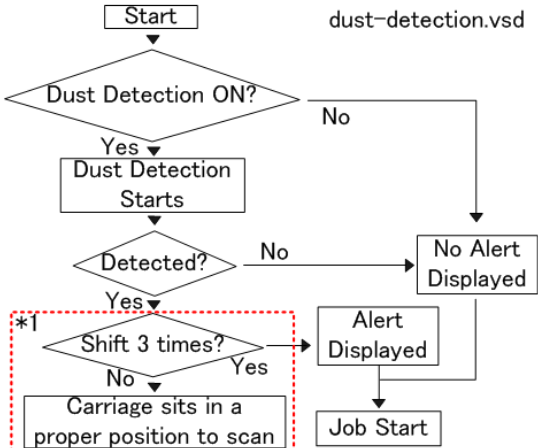

\*1 For details, see "Scan Point Shift" below.

### 4.2.7 SCAN POINT SHIFT

When dust detection determines that dust exists, the scan point shifts in order to avoid the dust. There are three scanning points; one is HP (Default), the others are 0.52 mm to the right (=b) from the HP and 0.52 mm to the left (=c) from the HP. The shift is "a > b > c > a > b" at any time.

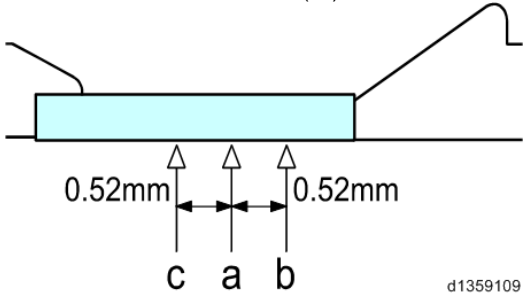

d1359109

## 4.2.8 ANTI-CONDENSATION HEATER

Under low temperature conditions, optical parts (mirrors) may become moistened. This will cause “image deletion”, “black out image”, and “gray image”. As a counter measure against this trouble, there is an anti-condensation heater [A] that is an optional service part. This heater turns on automatically when the power source turns off.

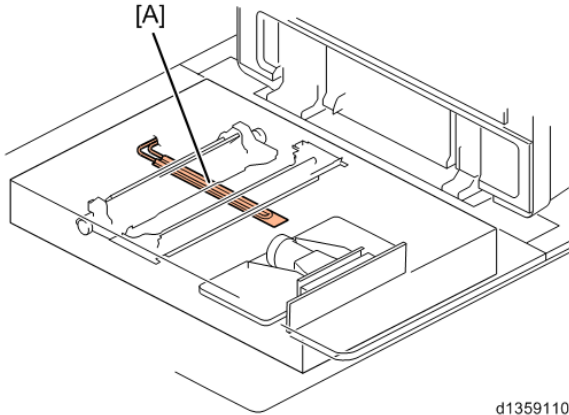

d1359110

A Anti-condensation heater

## 5. IMAGE PROCESSING

### 5.1 MECHANISM DESCRIPTIONS

#### 5.1.1 BLOCK DIAGRAM

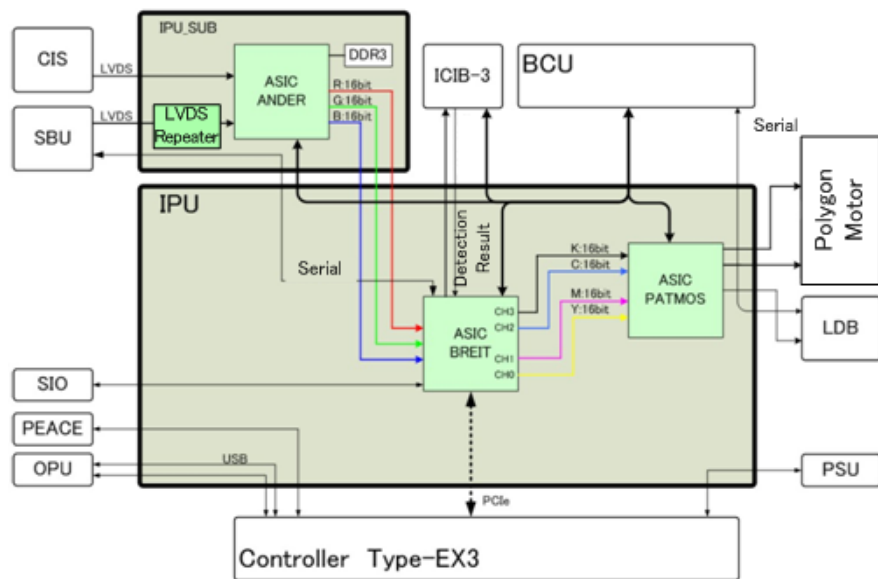

ptop.vsd

#### 5.1.2 MECHANISM DETAILS

- ◆ **SBU : Sensor Board Unit**  
Converts image light signals into digital image signals and transmits them to the IPU
- ◆ **Scanner Data Processing**  
Scanner processing includes black level correction, white level correction, gray balance correction, and an AE function.
- ◆ **Epitomization**  
In this operation, each 4-type analog signal (ODD / EVEN, F/L) from RGB of the 3-line CCD, is sampled by CCD signal processing. And the sampled signals are converted into digital value with the built-in 10-bit A / D converter.
- ◆ **Characteristic Value Memorization**  
SBU Characteristic is stored in the BCU. This characteristic value needs adjusting when the lens block is replaced.
  - SP4-008-001
  - SP4-010-001
  - SP4-011-001
  - SP4-688-002

◆ **Anti-Scumming for DF Printing**

You can prevent scumming with the SP mode below. This SP helps to adjust DF scan density referring to platen density.

- SP4-688-002

◆ **Test Mode**

There is the SP mode that generates VPU test pattern as a SBU malfunction diagnosis. After setting this SP, press [Start] button and a VPU test pattern is output. You can check a SBU state with this output image.

SP4-907-002

<SP4-699>

0: Default / Image output

1: Test pattern output / Fixed-value output (682-digit)

2: Test pattern output / Horizontal gradation pattern (10-bit tone, 2-dot /step)

3: Test pattern output / Vertical gradation pattern (10-bit tone, 2-line /step)

4: Test pattern output / Grid pattern (20mm x 10mm Grid pattern)

◆ **IPU Function Outline (IPU: Image Processing Unit)**

- Scanner Control
- Converts images signals into various types of image, and outputs to the controller (memory) through a PCI bus
- Receives image signals from the controller (memory) via a PCI bus, and converts them into images to output to the LDB
- Output Sheet-through ADF control signal
- Relays various types of signal and power source

◆ **Image Processing Outline**

In the IPU board, digital data that is transmitted from the SBU passes through processes such as a shading correction / a line-to-line adjustment / image processing. Then image data turns into digital signals (2-bit /pixel, 4-bit /pixel) that are sent to the printer unit.

◆ **IPU Image Data Flow**

See the block diagram shown above.

## 6. LASER UNIT

### 6.1 OVERVIEW

#### 6.1.1 GENERAL

This machine has two laser units (right: C, K / left: Y, M). Writing is done with a polygon motor, a LD unit, and four synchronization detectors (front / back).

#### 6.1.2 COMPONENTS

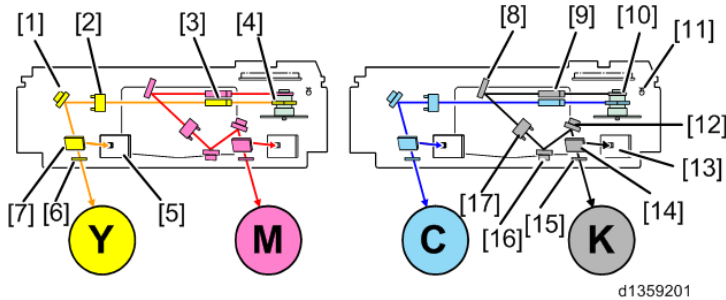

- 7. 1st Mirror (Y)
- 8. Scan Lens L1 (Y)
- 9. Scan Lens L2 (Y)
- 10. Polygon Mirror
- 11. Laser Synchronization Detector (Y) [Rear edge]
- 12. Dust Shield Glass
- 13. Laser Synchronization Mirror (Rear edge)
- 14. 1st Mirror (K)
- 15. Scan Lens L1 (K)
- 16. Polygon Scanner
- 17. Thermistor
- 18. 3rd Mirror (K)
- 19. Laser Synchronization Detector (Front)
- 20. Laser Synchronization Mirror (Front)
- 21. Dust Shield Glass
- 22. 2nd Mirror (K)
- 23. Scan Lens L2 (K)

Overview

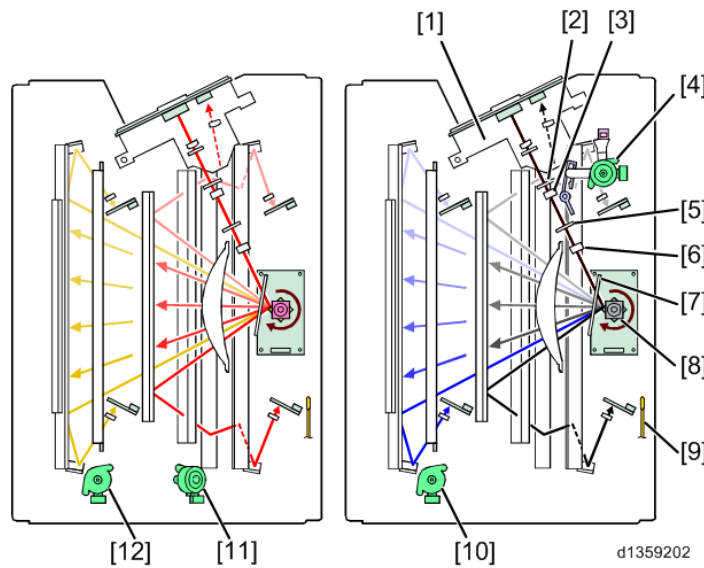

- 24. LD Unit
- 25. ND Filter
- 26. PBS
- 27. Shutter Motor
- 28. Quarter Wave Plate
- 29. Cylindrical Lens
- 30. Dust Shield Glass
- 31. Polygon Mirror
- 32. Thermistor
- 33. Skew Correction Motor (C)
- 34. Skew Motor (M)
- 35. Skew Motor (Y)

**Comment [オブライエン10]:** This drawing is not in book graphics directory – some others also – please make sure all diagrams used are in book-graphics

RE: 12/25/12  
I brought lacking pictures. Sorry for troubling.

**Comment [オブライエン11]:** Looks like 10 is for C, 11 is for M, and 12 is for Y – K does nit have – this is normal

RE:12/25/12  
Certainly, this is very strange. I modified.  
Thanks for pointing out.

## 6.2 DETAILS

### 6.2.1 LD UNIT COMPONENTS

The VCSEL method is adopted in this machine, as in the ProC751 series, but the components are different.

In the ProC751 series, there are VCSELs for each color and hexagonal polygon scanner mirrors. But this machine has two VCSELs (one for K/C and one for M/Y) [B] and two four-sided double-layered polygon scanner mirrors [A].

This machine uses VCSEL technology as ProC751 does, and realizes a high image quality (approx. 4800dpi x 4800dpi). But the components and the control method are different from those of the ProC751.

The polygon mirrors [A] of this machine are smaller than those of the ProC751 series. But this machine realizes not only the same image quality as the ProC751 series, but also a cost reduction because only two VCSELs are enough.

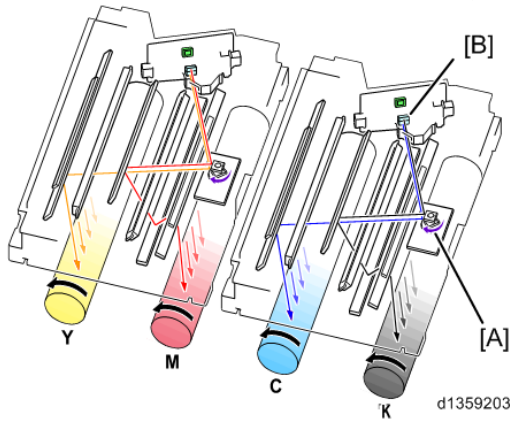

#### [Writing Control Method Difference]

In the ProC751EX series, each VCSEL emits a beam for one color. While in this machine, with a prism, one VCSEL can emit a beam for two colors.

In this machine, VCSEL emits beams alternately (K > C > K > C). A beam from VCSEL is divided into two beams with a prism. One of the beams is used for K and heads to the upper polygon scanner; the other of the beams is used for C and heads to the lower polygon scanner. When the K-use beam heads to the drum, the C-use beam doesn't head to the drum because there are differences in reflective-surface directions between the upper polygon scanner and the lower polygon scanner. While the K-use beam doesn't head to the drum when the C-use beam heads to the drum.

ProC751EX Series

**Comment [n 12]:** Not Complete

**Comment [n 13]:** I also cannot sure whether 20 LDs of 40 LDs make one color, or 40 LDs make two colors. It seems difficult to find with the original Japanese text. But I think maybe the former (20LDs - one color) is correct. Anyway, as you say, we need to ask someone else to make sure.

前機種ではそれぞれの LD ユニット1つが1つの色のビームの役割を担っていた。今回はプリズムを使うことによって、1つの LD ユニットにおける1つのビームに2色の役割を担わせている。KとCを例に考える。VCSELからは、K→C→K→Cとビームが出ている。まず、Kのビームはプリズムで二分割され、半分はK用のビームとしてポリゴンスキャナーの上段へ、残りはC用ビームとして下段に反射する。K用ビームは感光体に向かってとぶが、C用ビームはポリゴンが上段とずれているため感光体方向へはいかない。VCSELからC用ビームが出てきたときには逆の現象が起こる。  
12/5

**Comment [オブライエン14]:** I am not sure, but I do not know how one beam can be split to make two different data streams – they are split just after leaving the LD unit – this description seems strange

**Comment [オブライエン15]:** It seems to me that out of 40 LDs in each unit, 20 are used for each color – the prism will send 20 of these beams to one color, and 20 to the other, depending on the position of the beam in the VCSEL array, it will be sent by the prism to one of two locations (e.g. K or C) – this is just a guess – I need to talk to project leaders

## Details

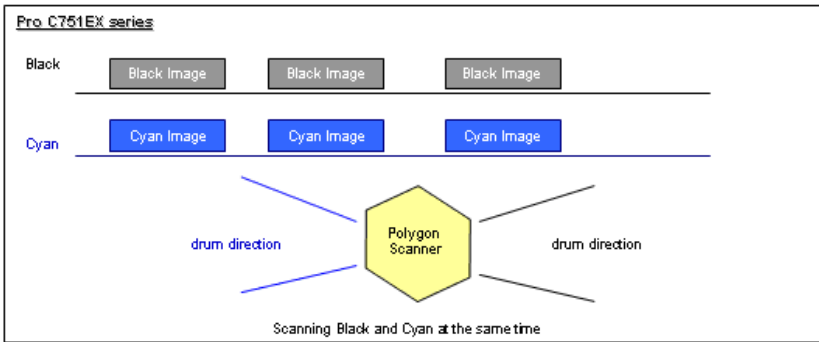

## ProC5100S/5110S Series

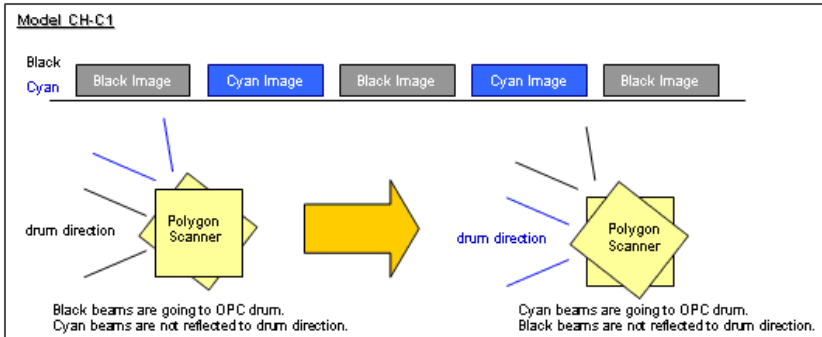

The emitting part is composed of ch1 to ch40 lines that writes with 40-beam.

The photo sensor [A] is installed on the LD board in order to detect laser output. LD Laser passes through the mirror [B] and the collimating lens [C] to the photo sensor [A] which detects its output. Laser heading to the polygon motor passes through the emitting surface part, the quarter wave plate [D] and the collimating lens [C]. And then the laser is emitted on the drum in vertical direction line manner.

VCSEL method contributes to reducing the polygon motor speed, curbing heat emission significantly, and energy saving.

\*VCSEL : Vertical Cavity Surface Emitting Laser

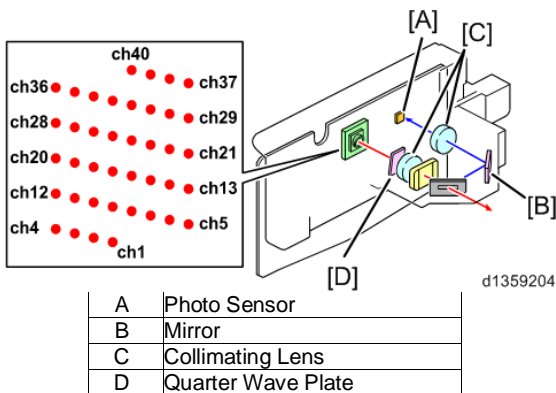

### 6.2.2 WRITING WITH 40 BEAMS

The VCSEL method has the following merits:

- Low current threshold / Low energy consumption
- High resolution for vertical writing (4800dpi)
- Polygon motor speed reduction (temperature reduction) / noise reduction, because 40 beams are writing

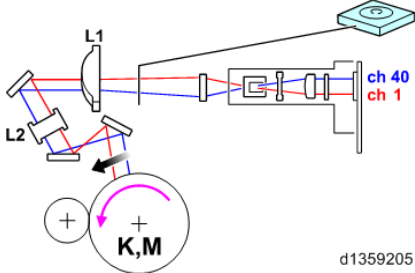

### 6.2.3 LD SAFETY SWITCH

There are four LD safety switches;

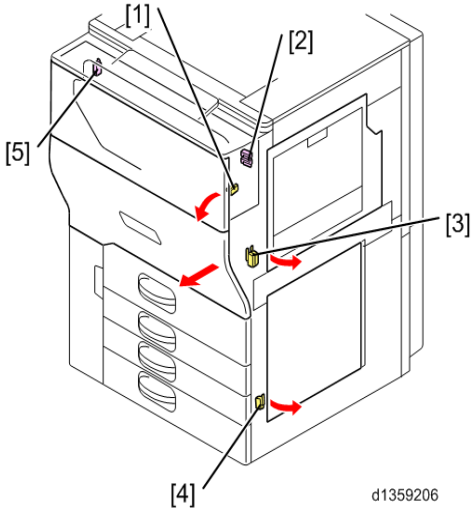

**Comment [ n 16]:** 3/15  
Diagram revised (No.5 sensor added)

1	Toner Supply Cover Safety Switch	3	Main Drawer / Bypass Cover Safety Switch
2	Toner Supply Unit Safety Switch (Pro only)	4	Vertical Transport Cover Safety Switch
5	Faceplate Set Sensor (Pro only)		

The LD safety switches prevent laser beams from being emitted when any of the following parts are open or not installed: bypass cover, vertical transport cover, main drawer cover, toner supply unit (Pro only).

The LD safety switches are installed on the 5V line that connects the PSU to the LD. To prevent the LD from emitting, the power supply to the LD is cut when any of the parts described above are open or not installed.

### 6.2.4 LINE SCAN

- **Mirror / Lens**

Each color LD unit emits light at the time of paper transfer, which heads to each color drum through the following parts; the cylinder lens (laser beam radial-adjustment), the polygon mirror (horizontal-line scan) [D], the scan lens (L1) [C], the 1st mirror [B], the scan lens (L2) [K], 2nd mirror [J], 3rd mirror [G], the laser synchronization mirror [N], the dust shield glass [M]. Lower layer (C, Y) beam goes to each color drum through the following parts: the cylinder lens, Polygon mirror [E], the scan lens (L1) [L], the scan lens (L2) [P], the 1st mirror [O], the synchronization mirror [N], the dust shield glass [M]

- **Polygon Motor**

The polygon motor [F] is composed of a motor and two mirrors attached on a drive axis (four-sided double-layered mirror). Laser beams are emitted to the polygon mirrors [D], [E] to write two colors alternately.

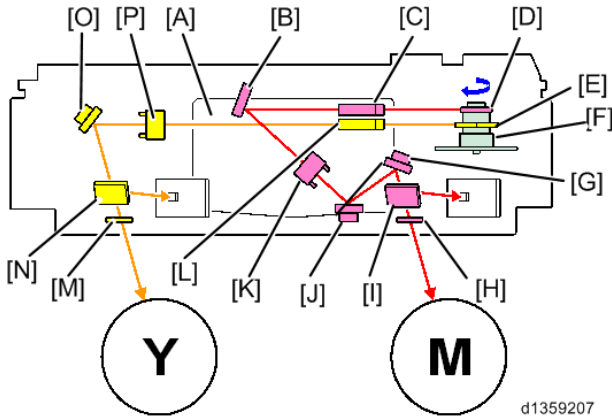

d1359207

- **Scan Lens Adjustment**

For each color, the scan lens (L2) [A] has an image skew correction motor [B] to correct skew. This corrects color registration errors in the main scan direction.

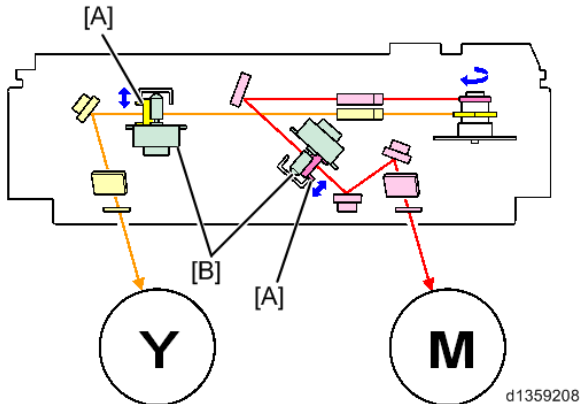

d1359208

### 6.2.5 IMAGE LOCATION CORRECTION

**Comment [n 17]:** This item will be brought to Replace and Adjustment in SM.

To prevent color registration errors, the machine makes a pattern on the ITB and reads it with the TM/ID sensor [A] that is installed near the drive roller of the ITB.



### 6.2.6 THERMAL CONTROL

The laser unit thermistor [A] in each laser unit monitors the temperature of each laser unit constantly. This sensor has the following role:

- Image location adjustment (adjusts the image location in response to changes in the internal temperature).

**Comment [オブライエン18]:** Looks like one in each laser unit

RE:  
Yes, I miswrote. So I corrected.  
And I plan to add the diagram below. Please wait.

A fan is installed at the back of the LD [B] in order to cool each laser unit.

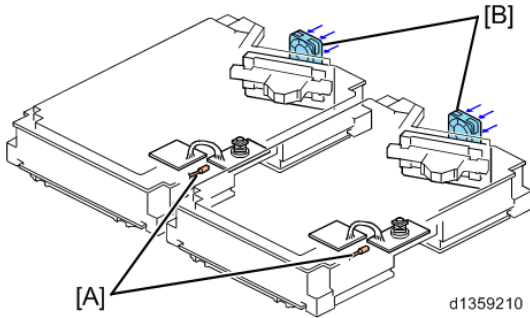
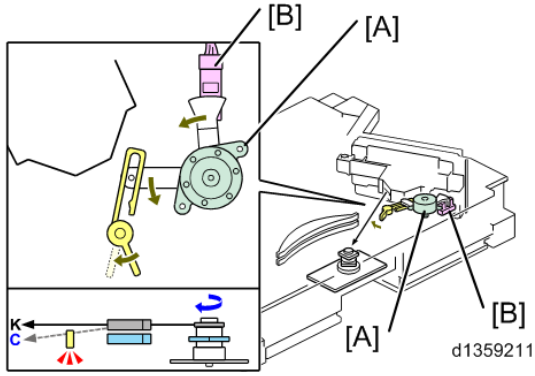

Diagram added 12/10

## 6.2.7 SHUTTER

A shutter is installed only in the LD unit for C and K. In BW mode, the shutter motor [A] shuts stray light for K out from the drum station for C. The shutter HP sensor [B] detects whether the shutter is active or not.



**Comment [オブライエン19]:** Sorry – don't understand

I re-wrote. "St. CYAN" means maybe "drum station for Cyan".  
And I plan to add the diagram below. Please wait.

Diagram added 12/10

# 7. PCDU

## 7.1 MECHANISM DESCRIPTIONS

### 7.1.1 GENERAL

This machine uses four photoconductor units (PCDUs) in tandem (one PCDU for each color YMCK). This mechanism is productive in full color and B/W copying. The PCDU is composed of the drum [D], the development unit [A], the cleaning unit [C], and the charge roller unit [B]. Each color PCDU can be drawn out of the machine. The parts in each color PCDU are exactly the same (a drum [D], a development unit [A], a cleaning unit [C], and a charge roller [B]) in order to improve the machine's price competitiveness.

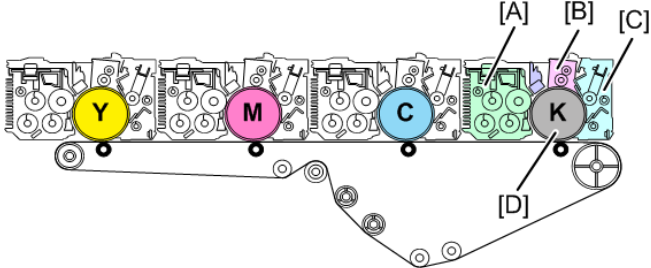

d1359401

### 7.1.2 AROUND THE DRUM

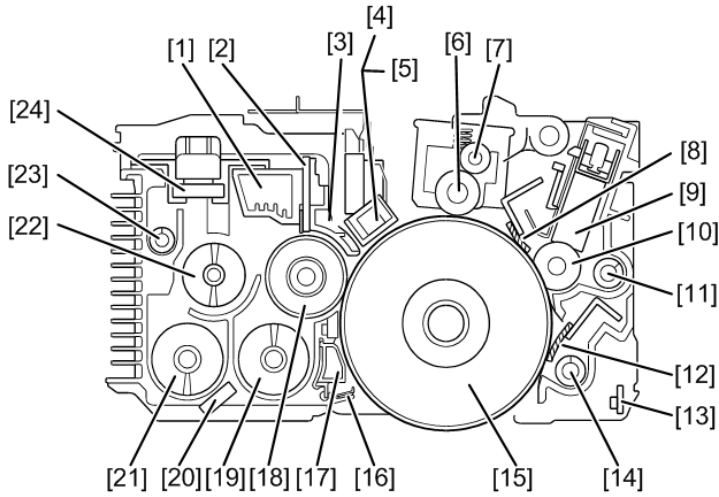

d1359402

1	Heat Sink	13	Quenching Lamp
2	Doctor Blade	14	Primary Collection Coil
3	Entrance Seal	15	Drum
4	Temperature / Humidity Sensor (K only)	16	Toner Catcher
5	Potential Sensor	17	Spill Duct
6	Charge Roller	18	Development Roller
7	Charge Roller Cleaning Roller	19	Right Transport Auger
8	Lubricant Blade	20	TD Sensor
9	Lubricant Bar	21	Left Transport Auger
10	Lubricant Brush Roller	22	Upper Transport Auger
11	Secondary Collection Coil	23	Developer Collection Coil
12	Drum Cleaning Blade	24	Vent Filter

## 7.2 DETAILS

### 7.2.1 CHARGE

#### ◆ Charge, Discharge

The charge roller [A] equally charges the drum for each color (the potential sensor [D] measures the charge). Before cleaning, LED emission [B] from the quenching lamp discharges the surface of the drum [C].

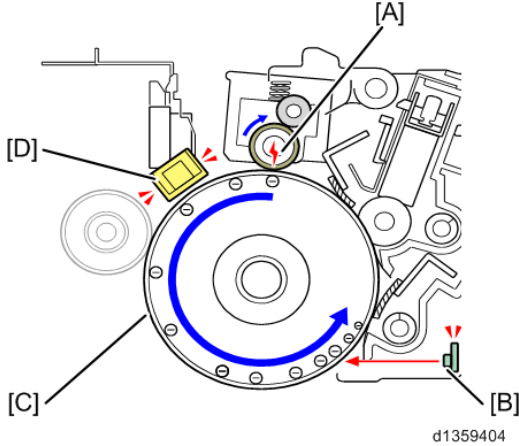

#### ◆ Charge Roller / Cleaning Roller

The charge roller [B] applies charge to the drum. The charge roller [B] is separated slightly from the drum surface and rotates in the opposite direction to the drum. The power pack supplies the charge roller shaft with the charge that is applied to the drum.

Uneven charge can occur if the charge roller [B] is dirty. The charge roller cleaning roller [A] cleans the charge roller to prevent this.

The charge roller cleaning roller [A] rotates in the opposite direction to the charge roller [B] in order to clean the surface of the charge roller.

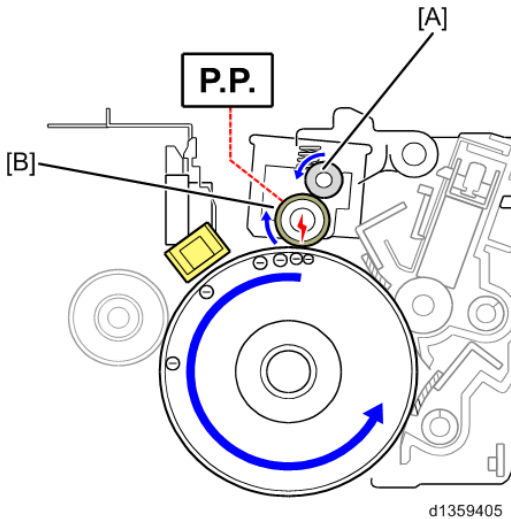

**Comment [オフライン20]:** What is driving the charge roller – does it have a motor?

RE:

Indirectly, the charge roller is driven by the drum motor. (the drum motor > the drum > the charge roller)

12/14: But the sentence says the roller is separated slightly, so how can the drive be transferred from the drum?

RE: 12/17

The roller is driven through the gear. It's the same manner as in Venus-C3.

Please refer to

\\colorppc\Charis-C1\theme\TTP\refpdf\charger\_venus3ttpref.pdf

(Relevant parts are marked in red)

**Comment [ n 21]:** 3/15/13  
Diagram and 1 sentence added

### 7.2.2 DRUM DRIVE

Each color drum has a drive motor [A]. The development unit and the cleaning unit have different motors to remove fluctuations in load in order to improve the precision of color registration. Two encoder sensors [C] monitor drum motor rotation and the signals are fed back to the drum motor to control the motor speed.

Only the Pro has the drum HP sensor [D] for anti-banding improvement.

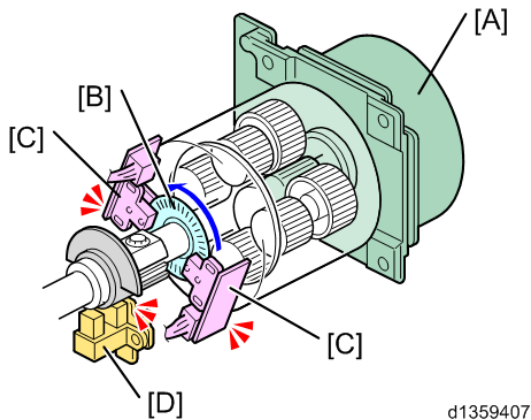

### 7.2.3 DRUM CLEANING

The lubricant brush [A], and the toner collection coils [B] and [C] are driven by the drum cleaning motor through the gears.

A counter blade method is adopted for the lubricant blade [D] and the cleaning blade [E]. The lubricant roller [A] rotates in the same direction as the drum in order to lubricate the drum surface. The lubricant blade [D] keeps lubrication on the surface flat.

Used toner that is collected with the cleaning blade [E] and lubricant are sent to the used toner transport area by the toner collection coil [C]. Lubricant and used toner are sent to the rear side and exited. There is a vibration plate in order to prevent lubricant condensation. This vibration plate shifts up and down in accordance with the rotation of the collection coil [B] and prevents the exit from clogging.

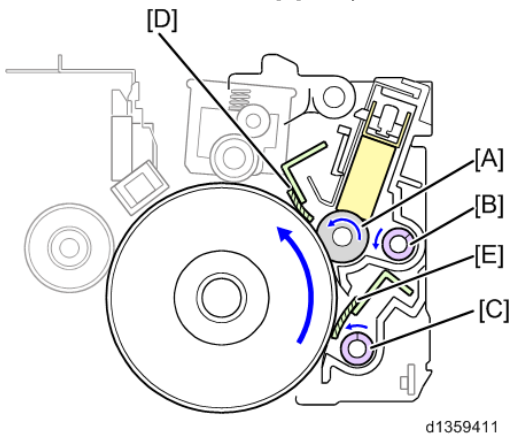

## 7.2.4 PG-FLUCTUATION REDUCTION TECHNOLOGY

To reduce PG-fluctuation that causes banding (50 mm pitch strips), the technology is employed in this machine, which reduces the change degree of the relative-position between the drum and the development R.

Pro C751EX/Pro C651EX has 16mm gap between the bearings of the development R and the drum, while this machine has approximately 1mm gap on the same part in order to reduce the change degree of a relative position when the development R receives sideways press or the PG plate distorts because of inaccuracies in the manufacturing process.

Owing to the reduction, this machine holds steadier PG than Pro C751EX/Pro C651EX when development R rotates, therefore banding is reduced.

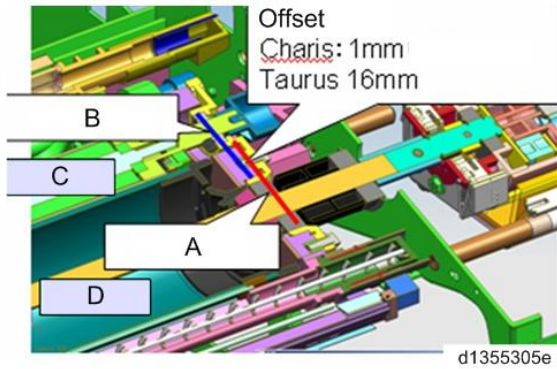

- A: Drum Shaft Bearing
- B: Development Roller Shaft Bearing
- C: Development Roller
- D: Drum

**Comment [オ布莱エン22]:** In the diagram, this gap is shown by the red line? What is the blue line? Is there a drawing with labels in English?

**RE:**  
This section might be deleted. So please wait until the decision.  
12/10

**Comment [n 23]:** 3/15/13  
Diagram changed

## 7.2.5 PPG-DRIVE

PPG-Drive is employed in this machine, which is smaller and low-cost. With FB / FF control, PPG-Drive can keep its rotation accuracy almost same level as the former model (Pro C751EX/Pro C651EX) does.

This means that this machine holds not only low-cost but also almost same accuracy as the former model has.

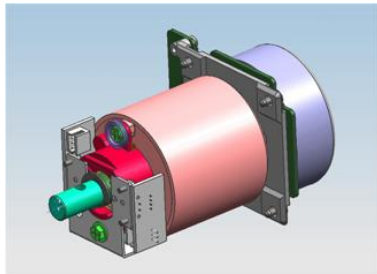

d1355079

## 7.2.6 LUBRICANT END DETECTION

This machine has a detection mechanism for lubricant end on the drum cleaning unit, in order to prevent the drum cleaning unit from deteriorating due to lubricant depletion.

### ◆ Lubricant End Detection Details

State	Descriptions
Lubricant Agent Detection	The lubricant agent extrusion part touches the feeler for the detection.
Lubricant Agent Near-end	<p>When the drum rotation reaches 10 km run, "The lubricant agent will run out soon." is shown on the operation panel as a near-end notification.</p> <p><b>DOM: Replace the cleaning unit.</b>  <b>EXP: Replace *both lubricant agent and lubrication roller.</b>  <b>*Both lubricant agent and the lubrication roller must be replaced because both lubricant agent and the lubrication roller affect the accuracy of the lubrication.</b></p> <p>The estimation of the print standard amount for the near-end;  <b>Office:</b> approx. 17k sheets (5P/J)  <b>Pro:</b> approx. 23k sheets (25P/J)</p>
Lubricant Agent End	<p>When the drum rotation reaches 17 km run, this machine stops emergently. "The lubricant agent runs out; Replace the drum cleaning unit." is shown on the operation panel as an end notification.</p> <p>The estimation of the print standard amount for the end;  <b>Office:</b> approx.29k sheets (5P/J)  <b>Pro:</b> approx.38k sheets (25P/J)</p>

### ◆ Lubricant Agent End Detection Details

A lubrication agent end detection [A] locates on the back of the lubrication blade on the upper side of the cleaning unit. Lubrication agent end detections also locate on the front and the rear side.

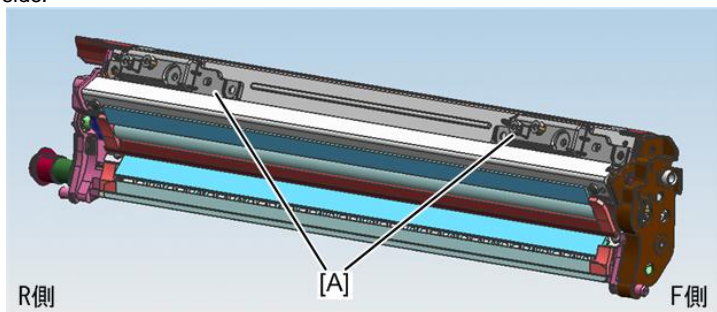

Two harnesses from the each lubrication agent end detector connect to the cleaning unit, while the cleaning unit connects to the main machine with four harnesses. The harnesses of the each detector come from electrode plate A [B] and electrode plate B [C] within the each detector.

**Comment [n 24]:** Some descriptions deleted 12/10

**Comment [オブライエン25]:** Replace at near-end?

**Comment [オブライエン26]:** Here we replace the entire drum cleaning unit Does this mean?  
 10 km: Replace lubricant and roller  
 17 km: Replace entire unit (even though we don't have near end yet for the new lubricant)?

RE:  
 If you replace lubricant and the roller, the feeler is lowered and reset. And then after 10km drum running, the near-end comes again. But when even the toner near-end occurs but no replacing lubricant and the roller is done, and the end detection occurs, you need to replace the entire unit.  
 So in other words, if you replace lubricant and the roller every time at near-end, you don't need to replace the whole unit (maybe not forever though).

Please refer to the below document about the feeler:  
 \colorppc\Charis-C1\theme\TTP\refdoc\lubrication\_electrode-plate\_text.xml  
 12/10

**Comment [オブライエン27]:** So, we have three things:  
 Feeler  
 10 km limit  
 17 km limit  
 Which determines near-end?  
 Which determines end?  
 The above description says near end is determined by the feeler, but earlier it says 10 km limit – is the 10 km an approximation?  
 What about the 17 km – is that a counter?  
 Actually, if 17 km is end, 10 km seems a bit early for near-end – or maybe 17 km is to replace the entire unit even if the lubricant bar is not near-end, as I said in an earlier comment.

RE:  
 Both 10km seem a suggestion from this machine developer but the rest 7km seems not. The feeler works up to about 10km. After near-end, I think something like a counter counts about 7km running.  
 So the feeler determines about 10km and the rest 7km is counted by a counter in the machine.  
 But I cannot be sure that there is a counter for the rest 7km. So we need to ask someone else to make sure.  
 12/10

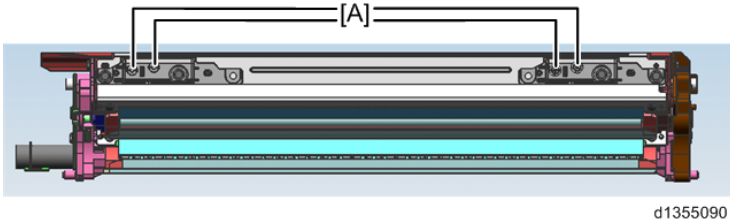

d1355090

## 7.2.7 DEMS (DEVELOPMENT ELECTRIC-FIELD MODULATION SYSTEM)

In PP market, there is relatively large number of demands for banding correction and color-variability correction because user sells output from the copy machine. As a counter measure against these demands, only ProC5100S/5110S has the technology, DEMS (Development Electric-field Modulation System).

In DEMS, an ID sensor that monitors an ITB detects periodical variation that causes density-variability. And then with referring to the detection result, development bias and charge bias is adjusted in order to determine the amount of toner attachment and to reduce color-variability.

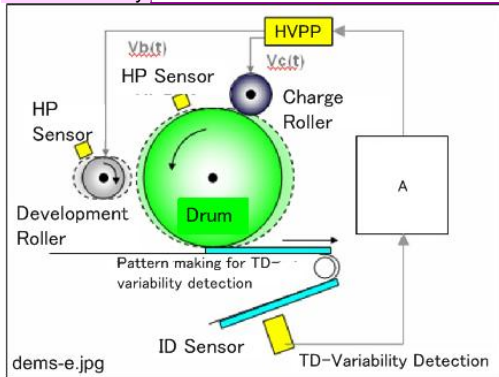

**Comment [オブライエン28]:** This seems about the same as normal process control – what is different here? What are the HP sensors in the diagrams? (Ninomiya san - These questions are for the project leaders, and so are many of the other questions, but if you know something, I would be happy to hear it.)

Descriptions	
A	Arithmetic Processing <ul style="list-style-type: none"> <li>▪ Average Processing</li> <li>▪ AC/DC Detection</li> <li>▪ Toner Attached Amount ↔ Voltage Conversion</li> </ul>

## 8. DEVELOPMENT UNIT

### 8.1 MECHANISM DESCRIPTIONS

#### 8.1.1 DEVELOPMENT LAYOUT

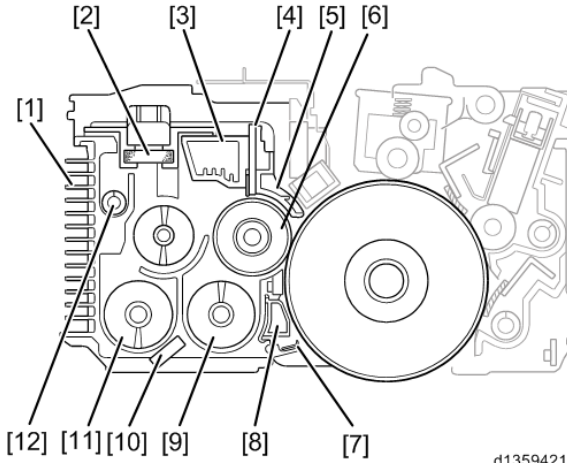

1	AI Heat Sink	7	Toner Catcher
2	Vent Filter	8	Spill Duct
3	Heat Sink	9	Right Transport Auger
4	Doctor Blade	10	TD Sensor
5	Entrance Seal	11	Left Transport Auger
6	Development Roller	12	Developer Collection Coil

#### Development Components

Development Method	Dry system 2-element magnetic brush development
Agitating Method	3-axis agitating method
Development Unit Drive	Individual drive in each color with a development motor
Development Bias	Applied from the power pack

**Comment [オブライエン29]:** What is an 'AI' Heat sink?

RE:

I consulted with Nagao-san.

And this seems to be suitable to be called "Casing with a heat sink"

By the way, there are some names of the parts wrong. So I corrected in pink. 12/12

## 8.1.2 DEVELOPMENT DETAILS

### Toner Supply System (Pre-mix Development System)

To keep image density steady, this machine adopts the development system where toner is mixed with a certain amount of developer before writing and then used developer is replaced by new one while operating.

When the existing 2-element developer is used, image quality varies gradually as a carrier ages, and regular developer replacement is essential to recover image quality. So replacement intervals are shorter and image quality possibly varies in every replacement.

The new toner supply method prevents carrier degradation in the developer unit by mixing a small amount of carrier with supplied toner and replacing developer gradually. This also helps to sustain developer longer and to stabilize image quality for a high speed copier. Toner contains approximately 30% of mixed developer (the same rate in all colors).

**Comment [ n 30]:** 2/20

The number is modified 7% to 30%.

#### a) Agitation Method

A 3-axis agitation method is adopted in this machine.

With three coils [C] [E] [F], toner that is transferred from the sub-hopper to the development unit is mixed with developer, and then the mixed toner is transferred to the development sleeve [B]. The amount of mixed toner and developer on the development sleeve is regulated by the doctor blade, and the mixed toner and developer attaches to the surface of the drum.

If too much developer is supplied, the excess amount of developer is exhausted with the developer collection coil [A].

The TD sensor [D] near the development auger [E] detects toner density.

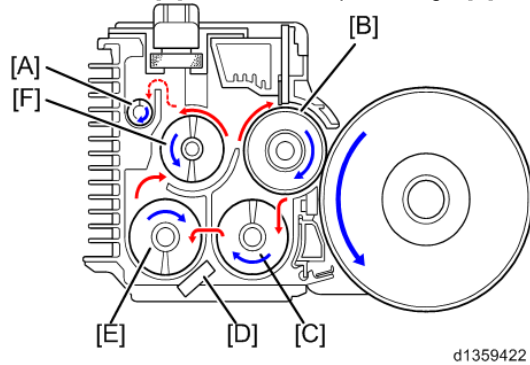

#### b) Development Unit Drive

The development motor [F] drives the development sleeve, the three augers [B] [E] [D], and the developer collection coil [A] through the couplings.

Each color development unit has a development motor [F] that drives each of the units.

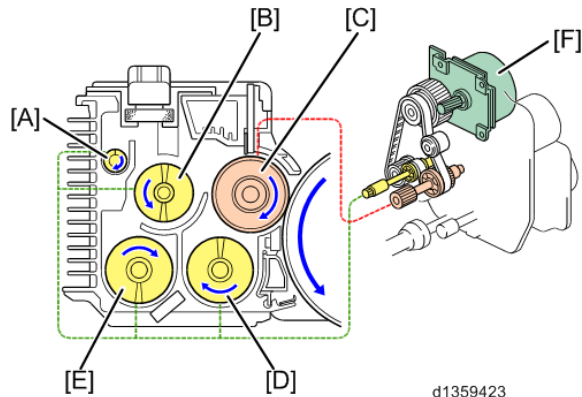

Only the Pro has the development roller HP sensor [A] for anti-banding improvement.

Comment [ n 31]: 3/15 added

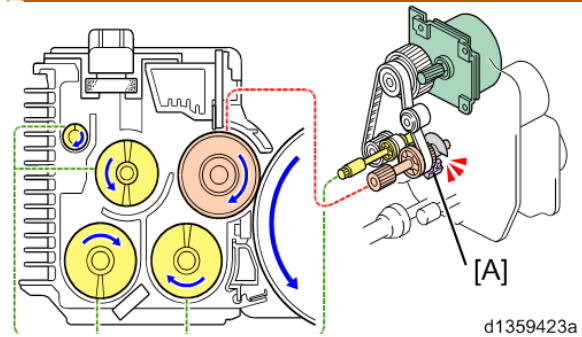

**c) Development Bias**

From the development power pack, development bias applies to the development sleeve axis.

**d) Toner Density**

The TD sensor [B] installed below the development auger (left) [A] detects toner density of developer.

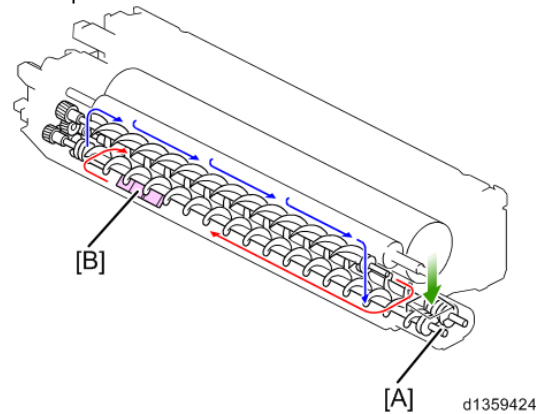

**e) Developer Turnover**

In pre-mix development system, toner and developer is supplied to the development unit. In case that too much amount of developer is supplied in the development unit, the extra amount of developer is exhausted from the rear.

The cam [C] attached on the axis of the transport auger (upper) [B] drives and it also fluctuates the lever [D] in order to rotate the developer collection coil [A] that exhausts developer out.

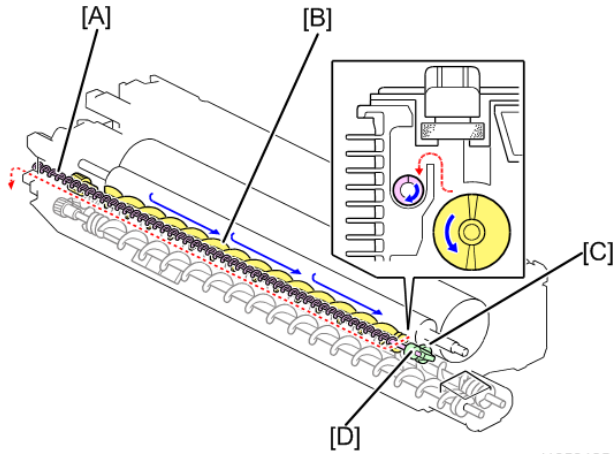

d1359425

**f) Dust Collection**

To prevent toner scattering and developer leaks, the spill duct [A] and the toner catcher [B] are installed. The spill duct has holes that take scattered toner in with a fan ([F] in the drawing for the next section). The toner catcher under the spill duct receives scattered toner that cannot be taken in by the duct.

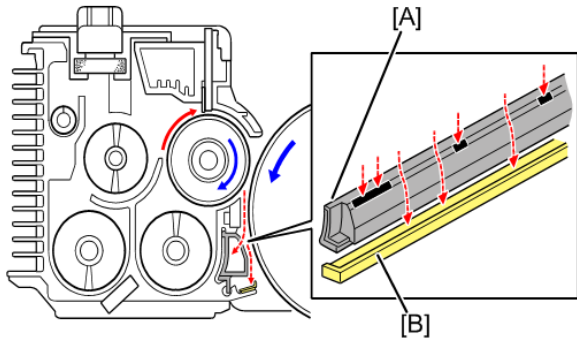

d1359426

**g) Air Ventilation**

To make ozone on the charge unit clean and exhaust it out of the machine, the blower fan [E] on the front side of each PCU draws air and exhausts it out through the fan [A] and blower fan [F]. Each blower fan has a dust filter [C] and an ozone filter [D], and the fan [A] has a dust filter [B].

Mechanism Descriptions

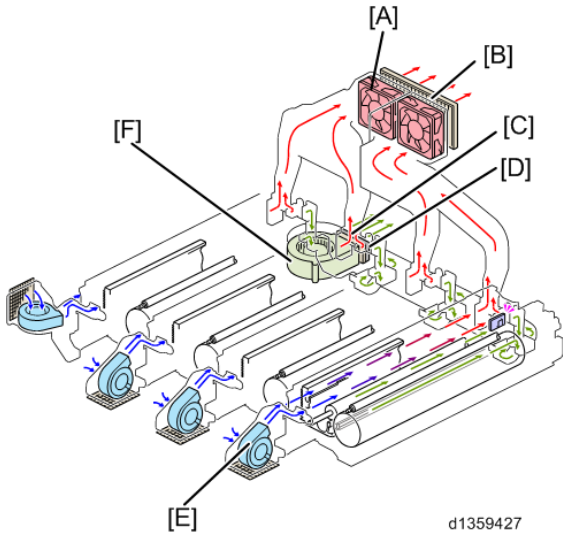

d1359427

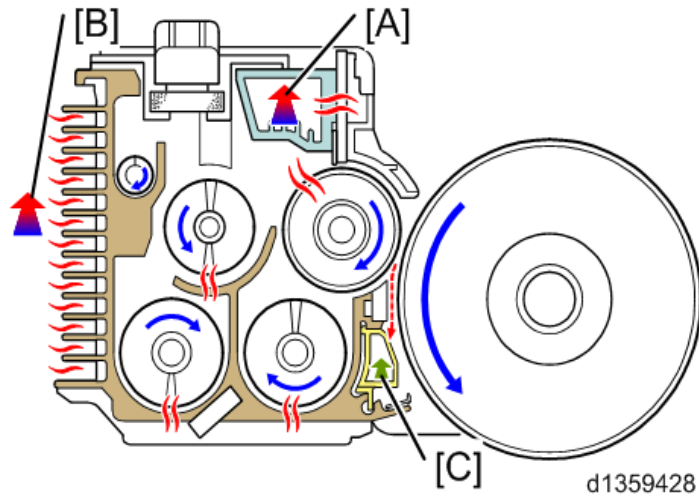

d1359428

A	The air current drawn to the fan [A] (for Y/M) or [B] (for C/K)
B	The air current from the blower fan [E]
C	The air current drawn to the blower fan [F]

## 9. IMAGE TRANSFER BELT (ITB) UNIT

### 9.1 MECHANISM DESCRIPTIONS

#### 9.1.1 GENERAL

An image that is transferred from the drum to the ITB is carried to the paper transfer part by the ITB. The carried image is transferred on paper in paper transfer roller (PTR) unit, and then the image transferred paper is separated from the ITB. The separated paper is transferred to the fusing unit through the paper transfer belt (PTB) unit.

#### 9.1.2 OVERVIEW

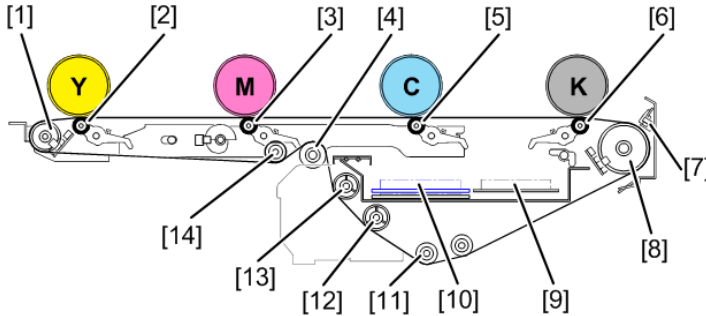

d1359501

1	Encoder Roller	8	ITB Drive Roller
2	Image Transfer Roller (Y)	9	DC Transfer Power Pack
3	Image Transfer Roller (M)	10	AC Transfer Power Pack (Pro C5100S/Pro C5110 only)
4	Tension Roller	11	ITB Bias Roller
5	Image Transfer Roller (C)	12	ITB Cleaning Blade Counter Roller
6	Image Transfer Roller (K)	13	ITB Lubricant Blade Counter Roller
7	ID Sensor	14	Back-up Roller

**Comment [オブライエン32]:** CVEC explanation says more than one roller has encoder, so we may need to review the part names here. – is this the driven roller?

RE:

Yes, this is driven, does not drive itself. In Taurus-c1, the same location roller is called "Belt Centering Roller". (I translated this roller literally. In Japanese it is called "エンコーダーローラー".)

12/11

## 9.2 MECHANISM DETAILS

### ◆ Drive

The ITB [A] is driven by the ITB drive motor [C] through the gear and ITB drive roller [B].  
 The encoder [D] detects the speed of the ITB drive motor.

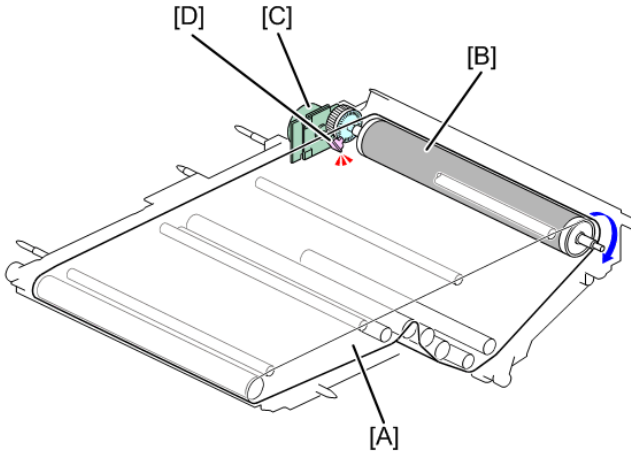

d1359502

### ◆ Transfer Bias

Bias is applied to the back of the ITB through each image transfer roller (image transfer). Minus-bias is applied to ITB bias roller in order to enhance image-transferability to damp paper. (repulsive image transfer method)  
 The power pack installed in the ITB unit offers each bias.

MP C6520SP/MP C8002SP

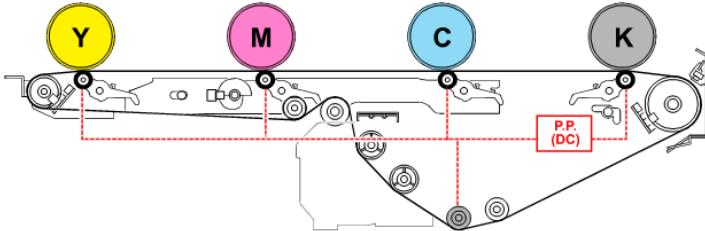

d1359503

Pro C5100S/Pro C5110S

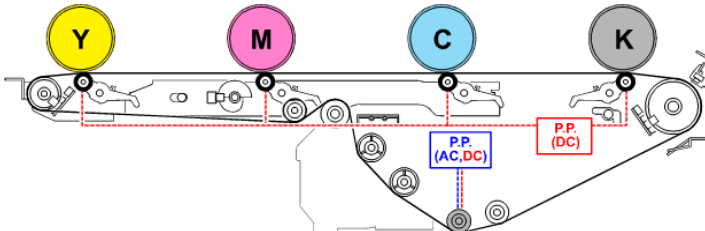

d1359504

### ◆ ITB Contact / Separation

The ITB adopts contact / separation mechanism where the ITB is separated from the color drums in BW printing in order to prevent a color drum (PCU) degradation.

In a BW / Color mixed job, the ITB performs separation / contact between color printing and

**BW printing.**

In BW printing, YMC drum (color drums) doesn't contact on the ITB.

The ITB contacts on only K drum (black) in the default position. In color printing, the transfer belt [C] is pushed up with the image transfer lift motor [A] through the eccentric cam [B] in order to contact on the color drums. In BW printing, only the K drum contacts on the ITB. The Contact detection is performed by the contact sensors.

In color printing after BW printing, BW printed paper passes through out the ITB unit, and then the image transfer roller lift motor [A] turns on and pushes up the transfer belt in order to contact the transfer belt on the color drums (Feed timing is controlled to make a space between the former passing paper and latter).

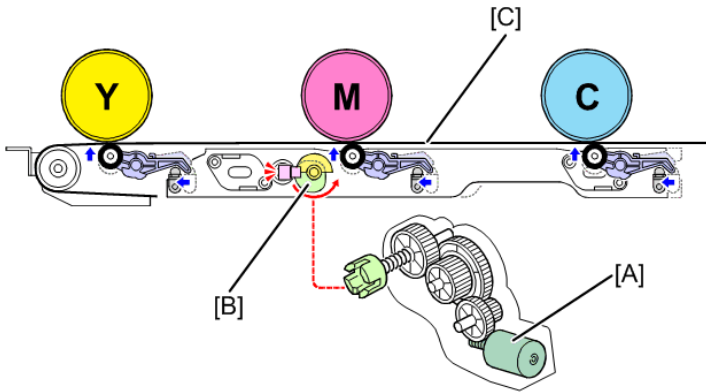

d1359505

◆ **Image Transfer Speed / Belt HP**

The Feedback control on the ITB speed is operated when the BW mode, the color mode, or MUSIC operation in order to enhance the preciseness of color correspondences. In this machine, the speed of encoder that is driven with the ITB is detected by the encoder sensor [B] that is installed near the encoder. The encoder sensor [C] detects the speed of the encoder attached on the ITB drive motor. These two detected speeds affect the ITB speed control. For more details, see the "CVEC" explanation described below.

The belt HP sensor [A] detects the point on the belt as the belt home position.

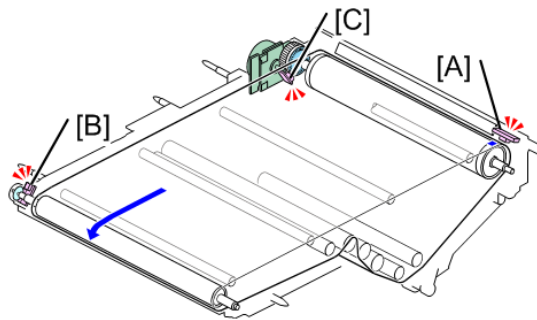

d1359506e

**Comment [オブライエン33]:** What is difference in function between A and C?  
 RE:12/17  
 Sorry, this sentence is wrong.  
 [A] is Belt HP Sensor. I re-wrote.

◆ **Thermal Control**

In this unit, the heater [A] is installed. This heater (ITB heater) prevents condensation from forming on the ITB.

The temperature / humidity sensor [B] is installed on the bottom of the machine (under the lowest PFU). It monitors the temperature inside the machine.

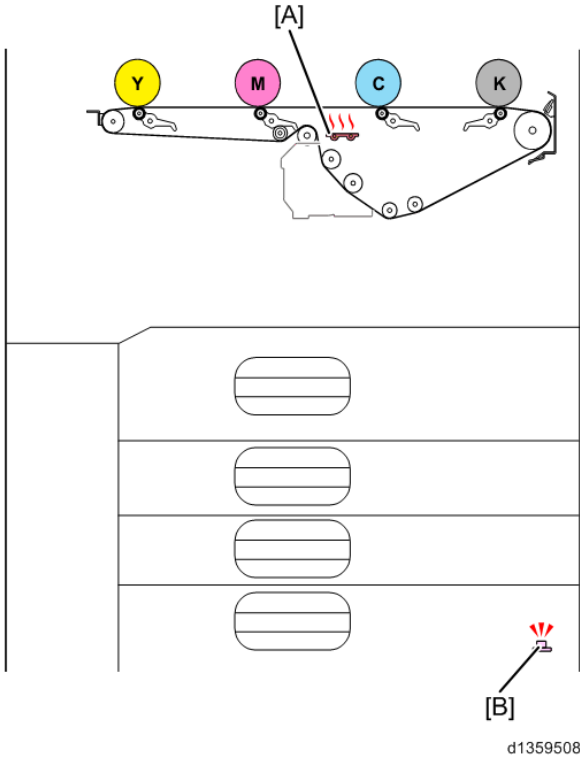

**Comment [オプライエン34]:** What does this thermal control do

RE:

This section is only introducing components related to temperature or humidity. This is not about mechanism so it might be better to move to another section.

◆ **CVEC(Compensation function of belt speed Variation of Encoder roller Cycle)**

CVEC (Compensation function of belt speed Variation of Encoder roller Cycle) means “a belt absolute position stabilization technology” that controls the speed fluctuation of the ITB. This technology is initially employed in this machine.

In the existing machines, a driven axis FB (feed back) method is employed where the speed of an ITB is detected through the driven roller rotation and feed back controlled. In this method, it is possible that the fluctuation in a speed detection occurs due to the shake of a driven axis or the eccentricity of an encoder that is attached on a driven axis. Besides, the existing machines curbs color deviation by relating station pitches with the circumference of a driven roller, but it's difficult to eradicate the occurrence of belt speed fluctuation and position deviation completely.

In CVEC technology employed in this machine, there are two encoders on the drive roller and the driven roller, in order to control the speed of the ITB. From the difference of the detections from the encoders on the drive roller and on the driven roller, the speed fluctuation of the driven roller comes out. From the data (the speed fluctuation), the phase amplitude of the driven roller that affects the fluctuation rate is calculated. Then the FF (feed forward) control where the drive control is done in anti-phase, is performed that realizes less than 50% of the speed fluctuation rate comparing to the existing machines.

**Comment [オプライエン35]:** Means: fluctuation in speed is reduced by more than half?

RE:12/17  
Yes.

CVEC Related SC Codes are as below (Logging only)

SC Code	SC Name
SC445-01	ITB Control Abnormal : Driven Axis FB
SC445-02	ITB Control Abnormal : Driven Axis Eccentricity Adjustment Control
SC445-03	ITB Control Abnormal : ITB Control Abnormal : Dancing Control

See "Trouble Shooting" for finding possible causes and counter measures.

## 10. ITB CLEANING UNIT

### 10.1 MACHINE DESCRIPTIONS

#### 10.1.1 OVERVIEW

##### Front View

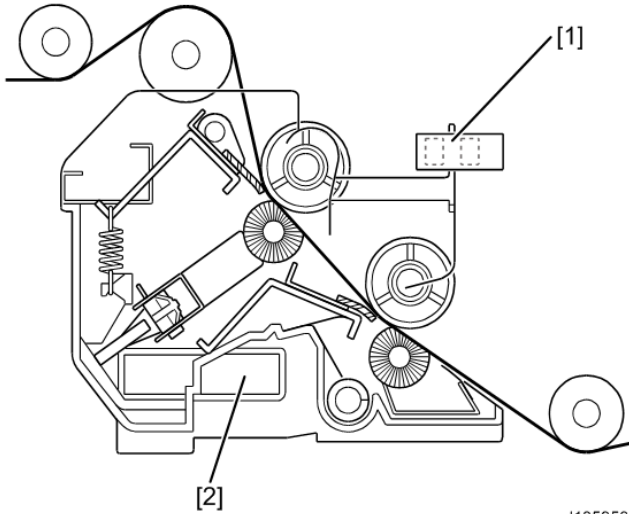

d1359531

1	ITB Cleaning Unit Set Sensor
2	Duct

##### Cross-Sectional View

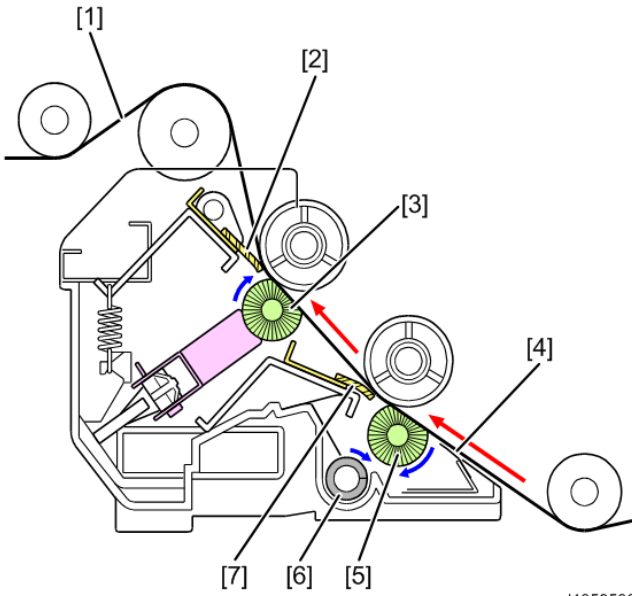

d1359532

1	Image Transfer Belt (ITB)
2	ITB Lubricant Blade
3	ITB Lubricant Roller
4	Paper Dust Collection Scraper
5	Cleaning Brush Roller
6	Collection Coil
7	ITB Cleaning Blade



---

# 11. PROCESS CONTROL

## 11.1 OVERVIEW

In electro photographic process, writing process condition for keeping the image quality varies due to the factors (humidity / temperature fluctuation, print mode (image dimension rate, P/J), and toner / developer / drum aging-degradation). So it needs to determine the proper condition by detecting the development ability of a machine at certain timing (development gamma).

Process control means controls that adjust image writing condition for keeping image density steady. In this machine, there are two-type controls as follows;

- **Potential Control:**  
Controls development potential that is a gap between potentials for the drum and development bias in order to keep targeted tone.
- **Toner Supply Control:**  
Controls the toner supply amount for the development unit in order to keep the amount of toner that attaches on paper steady.

To perform process control correctly, a machine requires "initializing" at the initial installation or at a replacement of the development unit / developer / the drum. "Initializing" performs the parameter initialization for the process control in order to keep up targeted tone based on the behavior (before aging-degradation) of a development unit, developer, and a drum.

## 11.2 COMPONENTS

### 11.2.1 PROCESS CONTROL COMPONENTS LAYOUT

This machine uses four photoconductor development units (PCDUs) in tandem (one PCDU for each color YMCK).

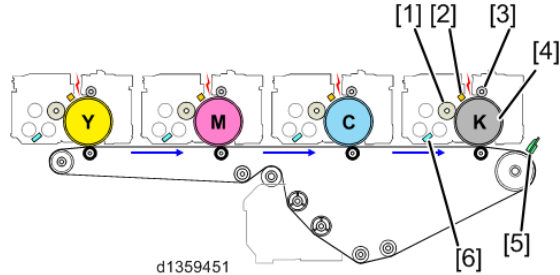

d1359451

1	Development Roller	4	Drum
2	Potential Sensor	5	ID Sensor
3	Charge Roller	6	TD Sensor

### 11.2.2 SENSORS FOR POTENTIAL CONTROL

#### ◆ Potential Sensors

Potential sensors measure electrical-potential on the surface of the drum, and are installed in the left upper side of the drum unit (viewed from the front of the machine). PCD units are set to each color station. The space between the drum surface and a potential sensor [A] is 3mm [B].

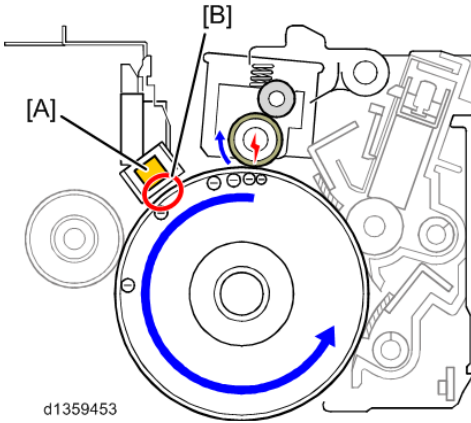

d1359453

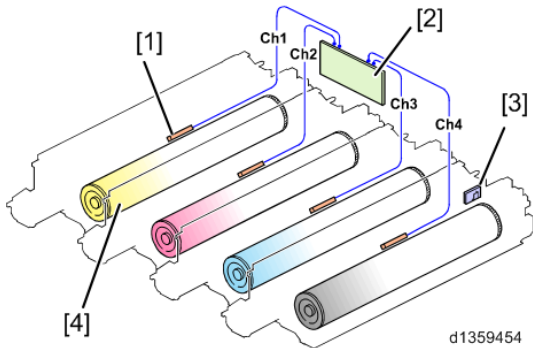

1	Potential Sensor	3	Thermo /Humidity Sensor
2	Potential Sensor Board	4	Drum

◆ ID / Music Sensor

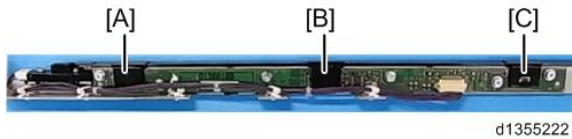
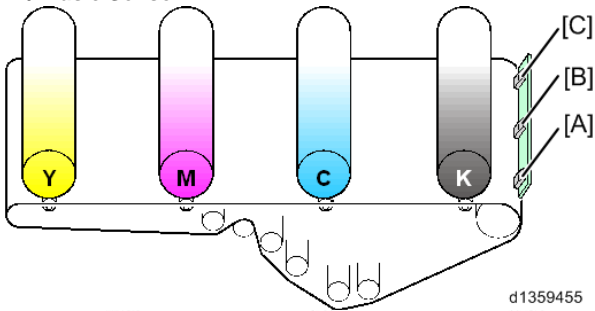

A	Front side
B	Center
C	Rear Side

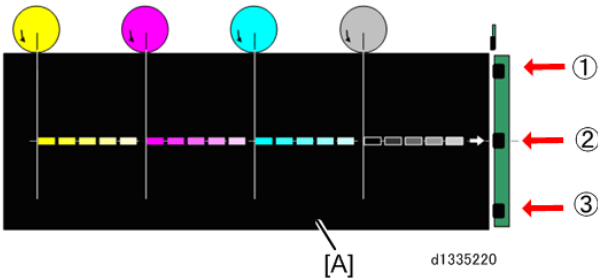

Tone Pattern on the ITB

A	ITB
---	-----

1, 2, 3: MUSIC Sensor = A sensor to detect MUSIC control patterns  
 2: ID Sensor = A sensor to measure the amount of toner that is attached on the ITB. This

sensor is used to detect patterns for image adjustment that is made at the time of potential control, and is also used to detect ID patterns on the drum between sheets.

◆ Temperature / Humidity Sensor

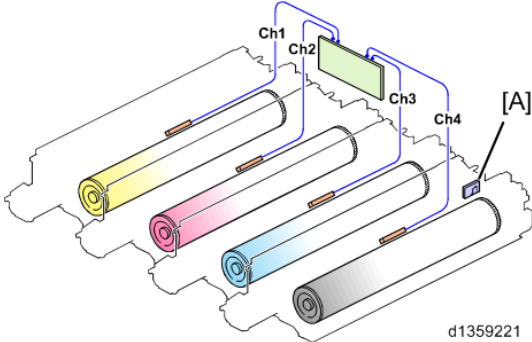

The temperature/humidity sensor [A] locates near the outside of the K (black) PCDU. A temperature/humidity sensor [A] that used to help potential control is installed on the left-upper-rear side of the machine where K (black) PCDU is assigned (shown above). This sensor affects potential control (developer agitation time, developer gamma (target value) determination) and AC current adjustment (drum charge).

**Comment [ n 37]: 3/7**  
 The first line: "Only K (black) PCDU has a temperature / humidity sensor [A] (shown above)." Is deleted.

O'Brien 3/8 – But there is only one sensor, right? And it is by the K PCU?

Ninomiya-3/15  
 Yes, this machine has only one temperature/humidity sensor that locates near on the outside of the K-PCDU. The description is deleted because in Japanese, it sounds that the PCDU includes the sensor in it's internal body. In English, it doesn't sound but I was asked to delete. So I put it in again with a little fix.

### 11.2.3 SENSORS FOR TONER SUPPLEMENT

◆ TD Sensor

A TD sensor [A] that reads the density of toner in non-contact developer is used to control toner supply. This sensor is attached under the development unit. This sensor has an ID chip that stores information for toner density control.

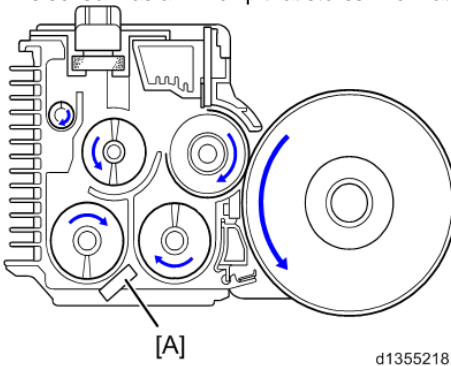

### 11.3 INITIAL SETTINGS

"Initial setting" means a process to initialize the process control parameter in order to keep up targeted tone based on the behavior (before aging-degradation) of a new development unit, new developer, and a new drum.

It's essential for a machine to perform "Initial settings" correctly at the initial installation or at a replacement of the development unit / developer / the drum.

If not, process control cannot perform correctly and wrong image density (too much thin or thick) / toner scatter in a machine possibly occur.

### 11.3.1 INSTALLATION, DEVELOPER REPLACEMENT

When the drawer is closed after new developer has been installed successfully (SP3-024-001), the TD sensor initial setting starts automatically and then the adjustments for image quality (AC current adjustment, transfer current adjustment, potential control, MUSIC). This completes the machine set up for operation. (See replacement adjustment in the main service manual for procedure details for developer supply, development replacement).

The automatic initial setting result comes out on the following SP codes:

SP	Name	Comment
SP3025-1	Dev Fill OK? - From Left: YMCK	Refer to "Trouble Shooting"
SP3031-1	TD Sens Init OK? - From Left: YMCK	Refer to "Trouble Shooting"
SP3012-1	ProCon OK? - History: Last	Refer to "Trouble Shooting"

### 11.3.2 OTHER INITIAL SETTINGS

The following initial settings below are required to execute respectively if necessary. (See "Trouble Shooting")

- ◆ **Initialize Processing (SP3020-1: Process Setup :Exe - Execute: ALL)**  
Touching [EXECUTE] starts this processing sequence:
  - Development auger agitation of developer
  - AC current adjustment for drum charge roller
  - Transfer current adjustment
  - Process control (potential control)
  - MUSIC
- ◆ **Initialize TD Sensor (SP3030-1 to 6: Init TD Sensor: Execute ALL, COL, KCMY)**  
Touching [EXECUTE] starts the development auger to agitate the developer then initiates the TD sensor.
- ◆ **Initiate Cleaning (SP3032-1 to 6: Cleaning Setup – Execute ALL, COL, KCMY)**  
Touching [EXECUTE] inputs the coverage pattern in the PCDU cleaning unit with the ITB retracted. The number of pages for the coverage pattern can be set with SP3032-21 (Default: 3)
- ◆ **Forced Toner Supply (SP3050-1 to 6: Force Tnr Supply – Execute ALL, COL, KCMY)**  
Touching [EXECUTE] activates the toner supply clutch to move toner from the sub hopper to the development unit. The amount of toner supplied with one execution of this SP can be set with SP3050-21 to 24 (Supply Quantity: KCMY). Default: 0.5wt%
- ◆ **Toner Filling (SP3051-1: Manual Toner Fill: Execute ALL)**  
Pressing [EXECUTE] moves toner from the toner bottle to the sub hopper
- ◆ **Image Quality Adjustment (SP3011-1 to 5: Manual ProCon Execute)**  
Touching [EXECUTE] for one or more of these SP codes executes one or more phases of image quality adjustment.

SP	Name
SP3011-1	Manual ProCon :Exe - Normal ProCon
SP 3011-2	Manual ProCon :Exe - Density Adjustment
SP 3011-3	Manual ProCon :Exe - ACC RunTime ProCon
SP 3011-4	Manual ProCon :Exe - Full MUSIC
SP 3011-5	Manual ProCon :Exe - Normal MUSIC

**Comment [オブライエン38]:** The order is TS sensor initialization, process control, MUSIC?

RE:

The first process is TD sensor initialization. And then the image quality adjustment (includes AC current adjustment, transfer current adjustment, potential control, MUSIC) Actually I cannot sure the order of the image quality adjustments but maybe Taurus-c1's descriptions are helpful. (The description form is somehow different but the same meaning.)

Please refer to  
 \Charis-C1\theme\TTP\refpdf\taurus-c1\_initial.pdf

**Comment [オブライエン39]:** Is there an SP to check MUSIC results?

RE:

I think there's no SP for MUSIC results. I brought this SP list from the existing machine TTP-ref (Taurus-c1). And in Taurus-c1 TTP-ref, there seems to be no descriptions about MUSIC results. Neither in the SP database.

# 11.4 POTENTIAL CONTROL

## 11.4.1 OUTLINE

Potential control is executed at prescribed times to perform adjustments in the copy process in order to achieve the target image density and produce the best quality images. These adjustments include changing drum charge bias, development roller bias, and LD power. Gradation patterns are created at prescribed intervals and read by the four potential sensors (one for each color) on the drum and the center ID sensor for the patterns on the ITB. The machine uses these readings to calculate development gamma for each color.

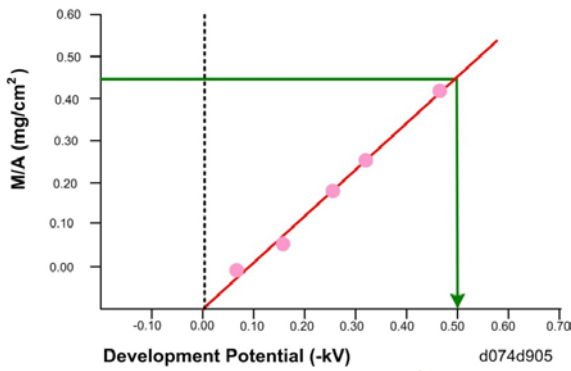
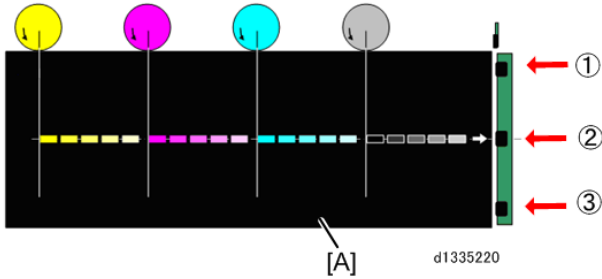

Development gamma from tone pattern → Calculating max potential

Comment [ n 40]: 2/1 changed

## 11.4.2 POTENTIAL CONTROL EXECUTION CONDITION

Potential control is triggered at the following conditions;

### ◆ Power ON or Power ON from energy saving mode

### ◆ Print Job Start

Any of the following conditions is met after the last print job has ended;

- Idle time  $\geq$  SP3532-1 (min.)
- Ambient temperature changed  $\geq$  SP3532-2 ( $^{\circ}$ C)
- Relative humidity changed  $\geq$  SP3532-3 (%RH)
- Absolute humidity changed  $\geq$  SP3532-4 (g/m<sup>3</sup>)

### ◆ During Printing

- Page counter for BW exceeds the interval setting for BW: SP3529-6 changed  $\geq$  SP3533-2
- Page counter for FC exceeds the interval setting for FC: SP3529-7 changed  $\geq$  SP3533-12

### ◆ Job End

- Page counter for BW exceeds the interval setting for BW: SP3529-6 changed  $\geq$  SP3534-2
- Page counter for FC exceeds the interval setting for FC: SP3529-7 changed  $\geq$  SP3534-12

### ◆ Front Cover Open Notification

The each varied value from the last time (just before power OFF) writing process end meets any of the following conditions;

- “Idle time  $\geq$  Time threshold (min.) <SP3530-1>”, and “Power ON: Sheet counter <SP3-530-007, 008>”  $\geq$  “Power ON: Sheet Interval [Sheet] <SP3-530-005, 006>”
- Ambient temperature changed  $\geq$  Temperature threshold [ $^{\circ}$ C] <SP3530-2>
- Relative humidity changed  $\geq$  SP3530-3 (%RH)
- Absolute humidity changed  $\geq$  SP3530-4 (g/m<sup>3</sup>)

**Comment [オブライエン41]:** Just to confirm – this means that the page counter is SP3529-6 and the interval setting is SP3533-2?

RE:  
Yes, you're right.

## 11.4.3 RESULT

The process control result comes out in the following SP with 8-digit code.

- SP3012-001

## 11.5 TONER SUPPLY CONTROL

### 11.5.1 OUTLINE

**[0: Fixed supply]:** The mode that fixes the amount of toner supply to the development unit. Do not use this mode unless you need to use this mode as a troubleshooting.

**[4: DANC Supply (with Vtref Correction)]:** Choose this mode normally.

\*DANC Supply = Divided image Active Noise Control (Image Divide Type Active Noise Control): The mode in which the necessary amount of toner is supplied to the area where toner is consumed in the development, in order to steady the toner density in the development.

If toner supply is calculated based on the amount of toner used in covered areas only, errors can increase, especially when changes occur in ambient temperature and drum characteristics. This makes it difficult to control toner supply only with pixel counts (pixel proportion control) to maintain constant image density.

Rather than depend on pixel counts in covered areas, several ID sensor patterns (Default: 10 patterns) are created on the drum and ITB between sheets. The machine uses two readings Vsg (reflectivity of the bare surface of the ITB in the patterns) and Vsp (reflectivity of the pattern areas covered with toner) to calculate Vtref. The value of Vtref is then used to set the toner reference voltage for the TD sensor. This reference voltage is frequently updated with fresh readings of the patterns to stabilize the amount of toner in the development unit.

### 11.5.2 ID PATTERN DETECTION TONER SUPPLY

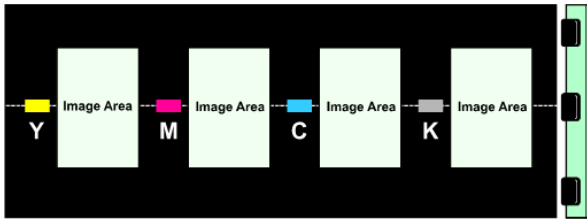

d1359456

In this machine, several ID sensor patterns (Default: 10 patterns) are created on the drum and ITB between sheets. The machine uses two readings Vsg (reflectivity of the bare surface of the ITB in the patterns) and Vsp (reflectivity of the pattern areas covered with toner) to calculate Vtref. The value of Vtref is then used to set the toner reference voltage for the TD sensor. This reference voltage is frequently updated with fresh readings of the patterns to stabilize the amount of toner in the development unit.

The target toner value is set in the following SP codes;

- K : SP3-620-001
- YMC: SP3-620-002~004

The default of the target toner values for each paper is as follows;

- Plain (Bk): 0.378mg/cm<sup>2</sup>, Color : 0.433mg/cm<sup>2</sup>
- Gloss (Bk): 0.378mg/cm<sup>2</sup>, Color : 0.389mg/cm<sup>2</sup>

Vt-Vtref affects toner supply control as follows;

- $V_t < V_{tref}$ : The supply will be decreased

- $V_t > V_{tref}$ : The supply will be increased

#### ◆ Acronyms Explanation

- $V_t$ : TD sensor output at the present time.
- $V_{tref}$ : Target output of the TD sensor. The machine always tries to adjust the toner WT% in the developer to bring  $V_t$  closer to  $V_{tref}$ .

### 11.5.3 OPERATION

- ◆ **When ID sensor patterns between sheets are thicker than the target (too much toner)**  
Trying to increase  $V_{tref}$  --> Trying to decrease the toner supply amount for the development unit
- ◆ **When ID sensor patterns between sheets are less thick than the target (too little toner)**  
Trying to decrease  $V_{tref}$  --> Trying to increase the toner supply amount for the development unit

## 11.6 LIST OF PROCESS CONTROL ACRONYMS

The potential control phase of process control involves many adjustments. Here is list of acronyms used in the descriptions of process control adjustments.

Acronym	Description
Vb	Development charge bias
Vd	Drum potential after the drum is charged by the charge roller.
Vl	Light potential. Development potential of areas on the drum exposed by the laser diodes. Maximum laser power has been applied to the diodes.
Vsg	ID sensor output after reading bare surface of the ITB
Vsp	ID sensor output from the most recent ID sensor pattern.
Vt	TD sensor output at the present time.
Vcnt	Gain value calculated during TD sensor initialization. This is used to adjust the $V_t$ (TD sensor output). A large gain increases $V_t$ , and a small gain decreases it. The result of this calculation is also used to calibrate $V_t$ during TD sensor initialization.
Vtref	Target output of the TD sensor. The machine always tries to adjust the toner WT% in the developer to bring $V_t$ closer to $V_{tref}$ .
Vpl	Electrical potential after laser exposure, with 24/63 of maximum laser power (power is controlled with PWM).

## 12. PAPER TRANSFER ROLLER (PTR) UNIT

Comment [n 42]: 3/13

All pics are renewed, some descriptions are revised (written in red)

### 12.1 MACHINE DESCRIPTIONS

#### 12.1.1 GENERAL

The ITB unit has transfer power packs for belt transfer and paper transfer. These power packs take a role of biasing not only the image transfer rollers for each color but also the ITB bias roller (upper roller) to transfer image on the belt to paper. The paper transfer roller (lower roller) drives in accordance with the ITB bias roller.

#### 12.1.2 COMPONENTS LAYOUT

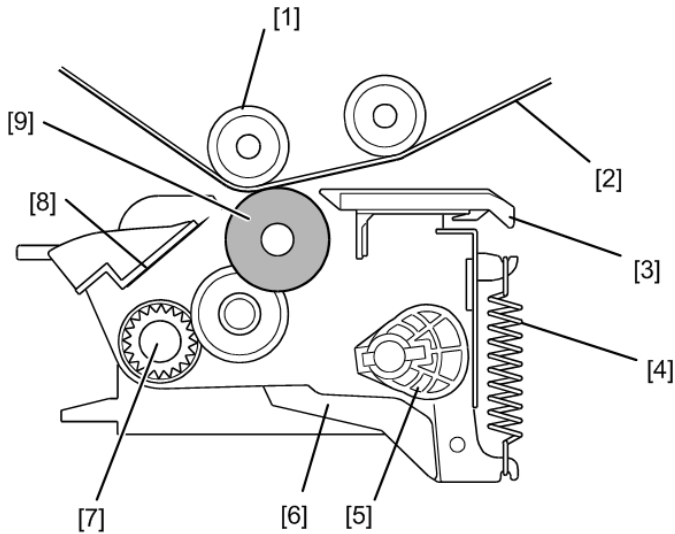

d1359551

1	ITB Bias Roller	6	Pressure Lever (front / rear)
2	Image Transfer Belt (ITB)	7	Fulcrum Shaft (PTR Drive Shaft)
3	Entrance Guide	8	Separation Electrode Plate (Separation Charger)
4	Pressure Spring (front / rear)	9	Paper Transfer Roller (PTR)
5	PTR Release Cam		

### 12.1.3 PAPER SEPARATION

In this machine, the PTR [A] and the curvature factor of the ITB [B] are used, and AC / DC bias is applied to the separation electrode plate [C], in order to keep separation ability steady.

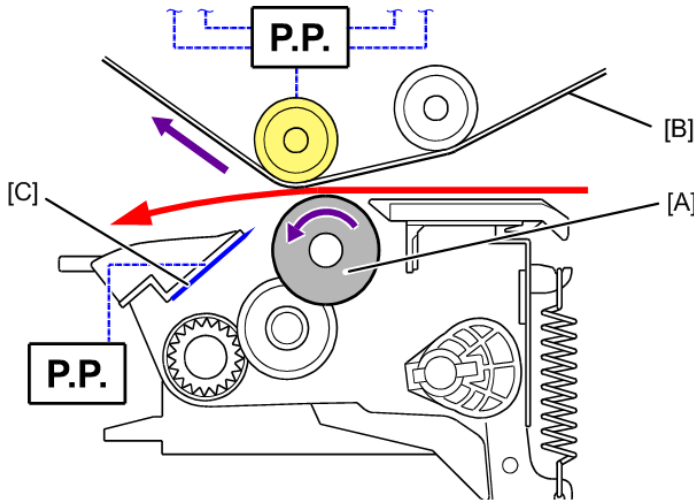

d1359552

### 12.1.4 PAPER TRANSFER ROLLER LIFT (PTR LIFT)

The ITB unit in this machine controls PTR lift in order to meet the following objects (the PTR roller moves onto or away from the ITB slightly enough to always press itself):

36. Not to let the PTR contact to process control patterns on the ITB when a process control applies to the ITB.
37. To prevent image transfer efficiency degradation, the PTR lowers before the leading edge of thick paper comes into, in order to prevent shock jitter due to thick paper plunge. After the leading edge comes into between the transfer rollers, a return control (lift) is done to nip paper with the transfer rollers.
38. To reduce cleaning burden by toner input reduction that applies to the PTR.
39. To secure paper transfer efficiency by not letting the transfer rollers keep contacting where the PTR may be concaved.
40. To keep an ITB run steady when its start-up. (enhancing a prevention of a belt slackness that can cause a brush against other parts)

#### ◆ Control Specifications

##### 41. General

The PTR lift motor [A] drives the cam [B] of the ITB bias roller. The PTR lift sensor [C] detects the actuator [D]. With this sensor [C], the machine judges whether the PTR contacts or not. This detection affects the PTR lift control.

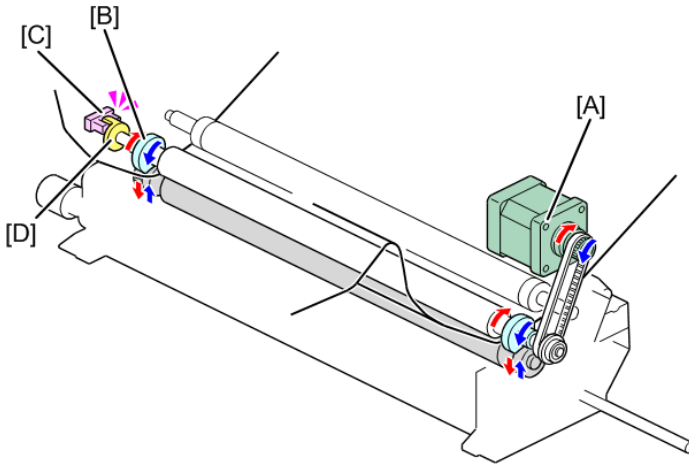

d1359553

As shown below, The PTR lift motor [A] rotates CW (clockwise) [1] or CCW (counter clockwise) [2] in order to rotate the bias roller cam [B] that determines whether the PTR contact on the ITB or not:

- Left: Contact State
- Right: Separated State

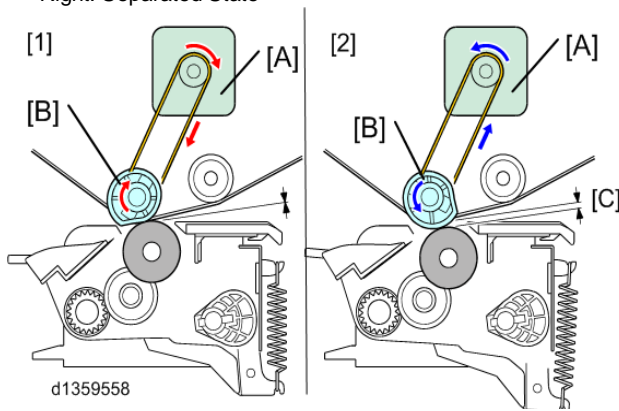

d1359558

You can find whether the PTR is in the contact or the separated state with seeing the direction of the flat face of the ITB bias roller shaft on which the bias roller cam [B] attaches.

[1]: Contact state → The flat face of the shaft directs to the left under.

[2]: Separated state → The flat face of the shaft directs to the right under.

In the "separated" state, the separation space [C] (indicates the space between the PTR and the ITB) is 1.5 mm regardless of paper thickness.

#### 42. The direction of the ITB bias roller cam

##### **PTR Separation**

The ITB bias roller cam [B] (bulge part) pushes the bearing of the PTR [C] down to separate slightly the PTR [C] and the ITB [A].

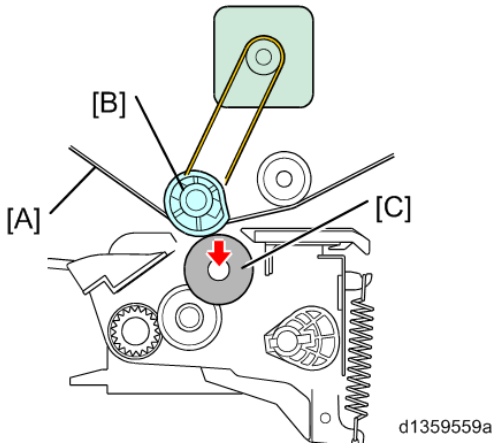

**PTR Contact**

The ITB bias roller cam [A] (flat part) contacts the bearing [B]. In this state, the PTR [B] can move up slightly higher than when the cam (bulge part) contacts the bearing.

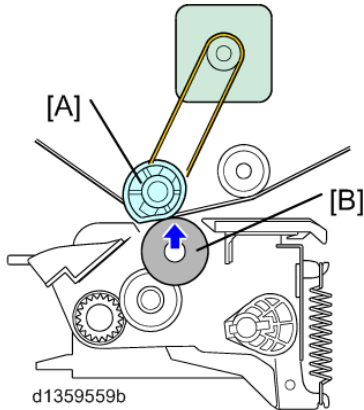

**43. Sensor State**

Sensor State	PTR State
Interrupted	Contact
Not interrupted	Separated (Home position)

**44. Contact / Separated State List**

See the list below to know when "contact / separation" operation is performed:

Machine State	PTR State	Remarks
Ready	Separated	
While printing	Color	Contact
	BW	Contact
Other States	Process Control	Separated
	MUSIC	Separated
	Forced Toner	Separated

Machine State	PTR State	Remarks
Consumption		
Lubrication Mode	Separated	
ITB Bias Roller Cleaning	Contact	

## 45. Shock Jitter Cancel Mode

To prevent a "go into" shock jitter (this tends to occur when thick paper goes into between the ITB and the PTR), this mode allows the PTR to separate from the ITB before paper goes into between the ITB and the PTR. After the leading edge of the paper reaches the nip area, the PTR becomes contact state. And then to prevent "go out" shock jitter (this shock occurs because the paper goes out between the PTR and the ITB), the PTR becomes separated state before the trailing edge of the paper goes out of the nip area completely (Default> Thick 1 ~ 4: "OFF" / Thick 5 ~ 8 "ON").

\*With default setting (shock jitter cancel mode: OFF), when paper that is thin but hard goes into between the ITB and the PTR, shock jitter may occur. In this case, switch the shock-jitter cancel mode on / off in the following SP codes:

Standard Paper	SP1-023-001~078	0:OFF/1:ON
User Setting Paper	SP2-841-001~100	0:OFF/1:ON

\*The timing of contact / separation can be adjusted in the following SP codes:

There is difference between the same kind of thick paper in its thickness and hardness. To receive this difference, in this machine, only "User Setting Paper" is adjustable.

**Contact Timing:** Larger SP values mean slower contact timing. "go into" shock jitter could diminish if you make the operation slower.

Standard Paper	SP1-021-001~078	PTR contact / separation timing adjustment: Contact
User Setting Paper	SP2-842-001~100	PTR contact / separation timing adjustment: Contact

**Separating Timing:** Smaller SP values mean an earlier start of the separating operation. "go out" shock jitter could diminish if you make the operation earlier.

Standard Paper	SP1-022-001~078	PTR contact / separation timing adjustment: Separation
User Setting Paper	SP2-843-001~100	PTR contact / separation timing adjustment: Separation

## 12.1.5 PTR RELEASE (SEPARATION)

46. The PTR pressure release motor [A] rotates the link (drive) [E].

47. The link (drive) [E] moves the link (driven) [C].

48. The PTR release cam [D] moves and the PTR [B] is released (separated).

**Comment [オブライエン43]:** What is shock jitter cancel mode?

RE: 12/18

Shock-jitter means when paper plunges into the little space nip between the ITB and PTR, shock will occur (especially thicker paper). This shock is called "shock-jitter".

To cancel this shock,

The rollers (PTR lower) separate to make a space not to occur a shock. When the leading edge of paper comes on the nip point, the rollers contact (PTR lift) and then separate (PTR lower) at the trailing edge of paper passing by.

**Comment [オブライエン44]:** What is the purpose of the pressure release mechanism – we already have the lift motor

RE: 12/18

This motor moves the PTR unit to the position where the PTR unit works.

While the lift motor lifts / lowers the PTR in the work area.

So I mean:

The PTR Release motor: Lifts up the PTR Unit to let it work. And lowers the unit not to allow it to prevent withdrawing the front drawer unit.

The PTR Lift Motor: Shifts up / down the PTR to help it work properly.

12/19/12 Thanks – when does this motor operate?

RE: 12/19

The PTR pressure is released (lowers the PTR unit) when you put your hand in the flapper on the main drawer unit (the lift-up of the flapper is detected by a sensor.).

And the PTR pressure roller lifts the PTR unit when you close the drawer completely.

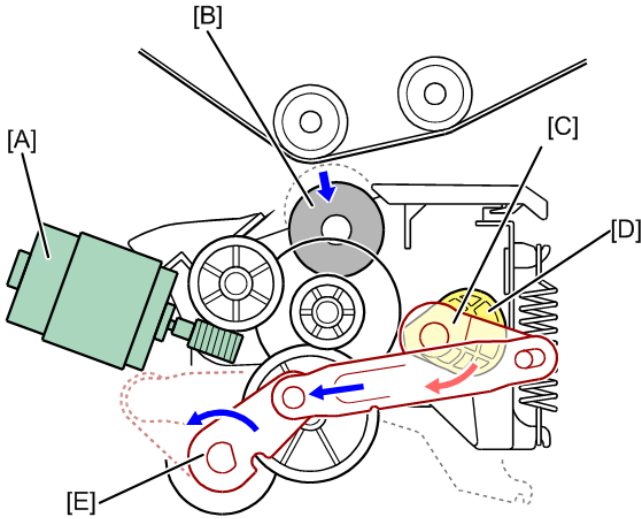

d1359554

### 12.1.6 PTR CLEANING

#### Bias Cleaning Method

- Residual toner lingering on the PTR [A] is electro-statically transferred to the ITB [B] in order to clean the PTR.

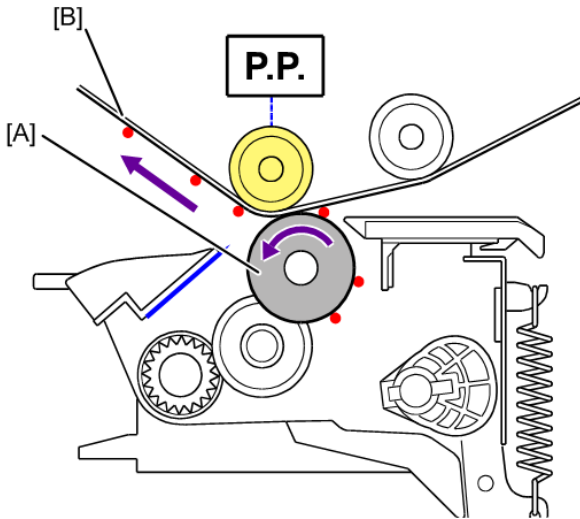

d1359555

#### Basic Operation of Cleaning Control

With the state that the PTR and the ITB contact, switching the polar character of an output from the PTR in turn in order to clean the PTR by transferring lingering toner on the PTR to the ITB. Switching minus output to plus output is one cycle. According to the operation timing, a certain cycles are performed. There are four patterns of the operation timing as follows;

49. FC Mode: All Machine Type: Four cycles

Cleaning is done while starting-up print job in FC mode, or PTR contact ~ PTR bias applying

for printing. Cleaning is not performed solo but performed while other process is done.

- 50. Bk mode: MPC6502SP/8002SP: two cycles / ProC5100S/5110S: four cycles  
Cleaning is done while starting-up print job in BW mode, or PTR contact ~ PTR bias applying for printing. Cleaning is not performed solo but performed while other process is being done.
- 51. At Recovery from an abnormal state: All type machines: Twelve cycles(SP settable)  
A control that is done when the machine recovers from abnormal-stop due to a jam or SC

Power Source on / Recovery (Recovery from an abnormal state)

Operation	SP Code
Cleaning Basic Operation Cycle Setting	SP-2-692-001

- 52. Non-frame trailing edge mode: x cycle (ProC5100S/5110S only) (SP Settable) ← The settable value is TBA.  
Only in this mode, cleaning is done between every sheet of paper. Before and after a basic cycle, no-image area current is output. The output times of no-image area current are affected by the PTR regulation cycle times that is settable in the SP.

### 12.1.7 PTR DRIVE

The encoder sensor [B] detects the speed of the rotation for the feedback control to adjust the speed of the PTR roller.

The PTR drive motor [A] drives not only the PTR but also the belt cleaning and the PTB.

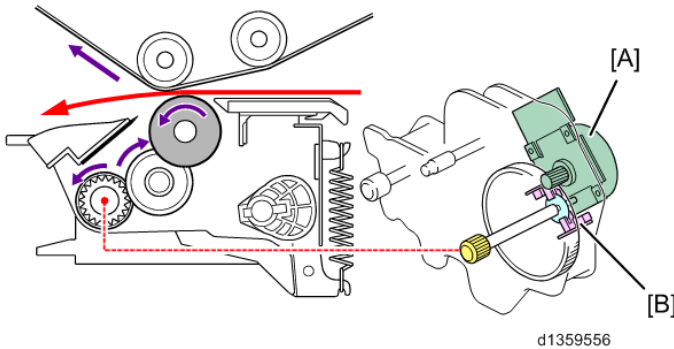

**Comment [オフライン45]:** Sorry – cannot understand well – according to this explanation, toner is sent back towards the ITB when paper still passes through – I think the customer doesn't like it

RE 12/18  
I corrected the descriptions. Cleaning is done not when paper-passing, but when between every sheet of paper (the time when paper doesn't pass by the ITB and PTR). I mean, the space between the former paper and the latter paper.

## 12.1.8 AC TRANSFER METHOD (PRO C5100S/PRO C5110S ONLY)

By changing the transfer method (DC or AC) alternately, correspondence for indentations on paper is enhanced. (You need to turn the setting on to use this method. The way to set is described later).

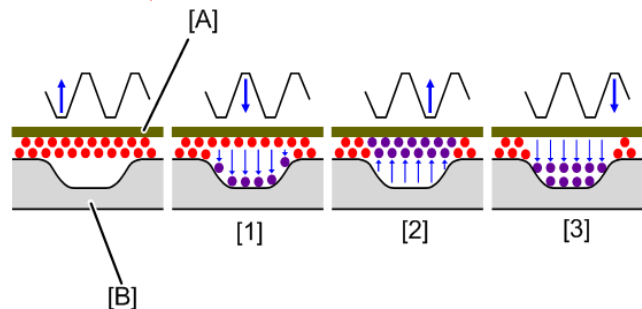

d1359507

A	Image Transfer Belt (ITB)
B	Indentation (Paper Surface)

	Descriptions	Applied Current
1	A portion of toner is transferred.	DC
2	Return toner contacts on toner on the ITB, which affects a toner attachment state.	AC
3	A toner attachment state changes, which makes toner easy to be transferred.	DC

This mechanism turns on in the following conditions shown below:

### <In Copy Mode>

- A specified tray is used that is linked with an AC kind\* of paper registered on the paper library.

### <In Printer Mode>

- A specified tray is used that is linked with an AC kind\* of paper registered on the paper library.
- A specified tray is used that is linked with an AC kind\* of paper registered on the paper library. Then you use the driver to designate an AC applied kind of paper as a kind for use.

\*AC Applied Kinds List:

	Vendor	Name	gsm	Size
NA	Neenah Paper	CLASSIC Linen (Solar White)	90	LT/12 x 18
NA	Neenah Paper	CLASSIC Linen (Solar White)	118	LT/12 x 18
NA	Neenah Paper	CLASSIC Linen (Solar White)	216	LT/12 x 18
NA	Neenah Paper	CLASSIC Laid (Solar White)	90	LT/12 x 18
NA	Neenah Paper	CLASSIC Laid (Solar White)	111	LT/12 x 18
NA	Neenah Paper	CLASSIC Laid (Solar White)	216	LT/12 x 18
NA	Neenah Paper	CLASSIC COLUMNS (Solar White)	90	LT/12 x 18
NA	Neenah Paper	CLASSIC COLUMNS (Solar White)	118	LT/12 x 18
NA	Neenah Paper	CLASSIC COLUMNS (Solar White)	216	LT/12 x 18
NA	Neenah Paper	CLASSIC COTTON (Solar White)	90	LT/12 x 18
NA	Neenah Paper	CLASSIC COTTON (Solar White)	104	LT/12 x 18
NA	Neenah Paper	CLASSIC COTTON (Solar White)	238	LT/12 x 18
NA	Mohawk Fine Papers	Via Laid (Pure White)	90	LT/12 x 18
NA	Mohawk Fine Papers	Via Laid (Pure White)	104	LT/12 x 18
NA	Mohawk Fine Papers	Via Laid (Pure White)	216	LT/12 x 18
NA	Mohawk Fine Papers	Via Smooth (Pure White)	90	LT/12 x 18
NA	Mohawk Fine Papers	Via Smooth (Pure White)	104	LT/12 x 18

Comment [n 46]: 3/15  
Added some parts (in red)

Comment [オブライエン47]: This is done by ITB bias roller, not PTR, isn't it?

RE: 12/19

Yes. In the explanation, only the surface of the ITB is mentioned. But actually, as you say, the ITB bias roller does this and an effect comes on the surface of the ITB.

Comment [オブライエン48]: Automatically selected by machine? Or user enables/disables

RE: 12/19

Sorry, this description is rather wrong.

In fact, AC / DC bias are applied alternately. AC attracts toner and DC pushes toner onto the paper as shown in the below diagram. I corrected the descriptions.

## Machine Descriptions

	Vendor	Name	gsm	Size
NA	Mohawk Fine Papers	Via Smooth (Pure White)	216	LT/12 x 18
NA	Mohawk Fine Papers	Via Linen (Pure White)	90	LT/12 x 18
NA	Mohawk Fine Papers	Via Linen (Pure White)	104	LT/12 x 18
NA	Mohawk Fine Papers	Via Linen (Pure White)	216	LT/12 x 18
EU	Conqueror	LAID Unwatermarked High White	100	A4/SRA3
EU	Conqueror	LAID Unwatermarked High White	300	A4/SRA3
EU	M-real ZANDERS	ZANDERS ZETA hammer white	100	A4/SRA3
EU	M-real ZANDERS	ZANDERS ZETA hammer white	260	A4/SRA3
EU	Arjo Wiggins	Hi White	100	A4/SRA3
EU	Arjo Wiggins	Hi White	300	A4/SRA3
EU	Zeta	ZANDERS Zeta Wove	100	A4/SRA3
EU	Zeta	ZANDERS Zeta Wove	260	A4/SRA3
EU	Fedrigoni	Freelife Merida White	280	110 x 220mm
EU	Fedrigoni	Splendorlux 1 extra white	250	SRA3
EU	Fedrigoni	Constellation snow E21	280	SRA3
EU	Fedrigoni	GSK extra white	110	SRA3
EU	Fedrigoni	SIRIO pearl aurum	300	SRA3
EU	James Cropper	Antelope Emboss	270	SRA3

With SP2-850-001 ~ 100, you can also turn on/off AC applying to each custom paper. But if an AC is applied to paper that is not registered as an AC applied kind, something wrong such as vertical streaks may occur.

# 13. FUSING UNIT

**Comment [ n 49]:** 3/14  
 Edited some parts (made some new sections)

## 13.1 OVERVIEW

### 13.1.1 FUSING UNIT LAYOUT

- MP C6502SP/MP C8002SP

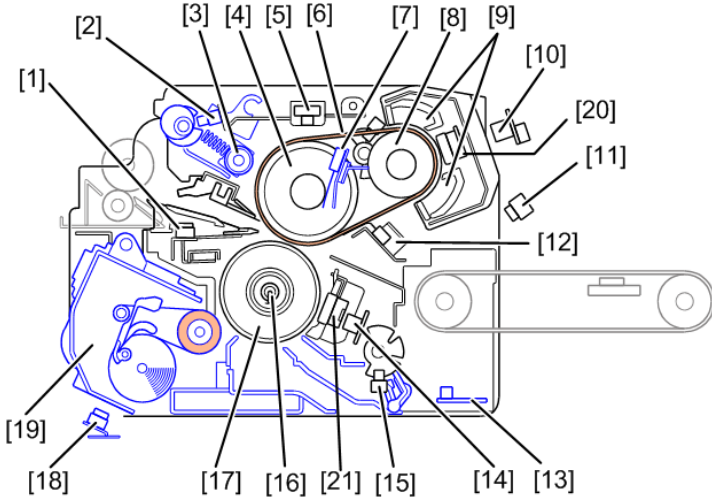

d1359751

1	Fusing Exit Sensor <b>Related Error: JAM024</b>	11	Fusing Entrance Paper Remaining Sensor <b>Related Error: JAM001</b>
*2	Belt Smoothing Roller Contact/Separation Sensor <b>Related Error: SC570</b>	12	Thermistor <b>Related Error: SC561, SC562-02/03</b>
*3	Fusing Belt Refresh Roller	*13	ID Chip
4	Hot Roller	14	Thermopile / Thermostat <b>Related Error: SC551, 552-02/ 03, SC543, SC544</b>
5	Hot Roller NC Sensor <b>Related Error: SC576, SC577</b>	15	Pressure Roller Cam Sensor (front / rear) <b>Related Error: SC569-04, SC569-02, SC562-03</b>
6	Heating Roller Rotation Sensor <b>Related Error: SC548</b>	16	Pressure Roller Fusing Lamp
*7	Hot Roller Thermistor <b>Related Error: SC579, SC580-03</b>	17	Pressure Roller

## Overview

	*SP1107-024 turns this thermistor on.		
8	Heating Roller	*18	Cleaning Web Set Sensor
9	IH Coil	*19	Cleaning Web Unit
10	Thermopile	20	Thermostat (Heating Roller)
21	Thermostat (Pressure Roller)		

\* The components with asterisks against the numbers are used only in Pro C5100S/Pro C5110S

### 13.1.2 ELECTRICAL COMPONENTS

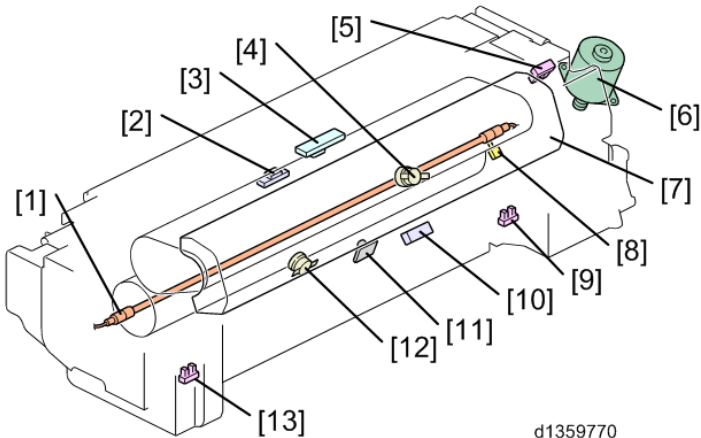

d1359770

No.	Name	No.	Name
1	Pressure Fusing Lamp	8	Thermistor (Fusing Belt)
2	Fusing Exit Sensor	9	Pressure Roller Sensor (Front)
3	NC Sensor	10	Fusing Entrance Paper Remaining Sensor
4	Thermostat (Heating Roller)	11	Thermopile
5	Heating Roller Rotation Sensor	12	Thermostat (pressure Roller)
6	Fusing Contact Motor	13	Pressure Roller Sensor (Rear)
7	IH Heater		

◆ Pro Only Components

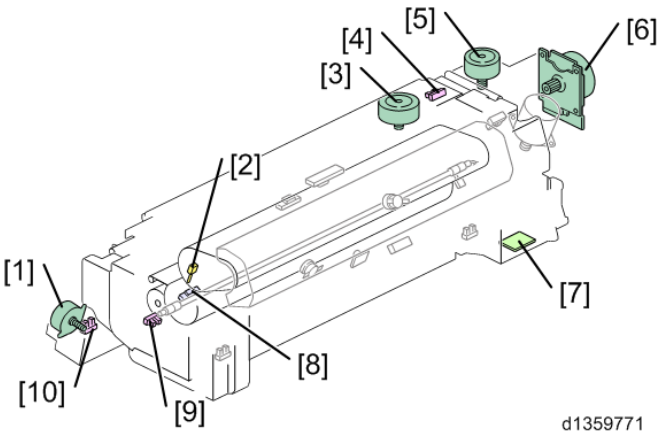

d1359771

No.	名称	No.	名称
1	Cleaning Web Drive Motor	6	Fusing Belt Smoothing Roller Drive Motor
2	Thermistor (Hot Roller)	7	ID Chip
3	Cleaning Web Contact Motor	8	Cleaning Web Unit Set Sensor
4	Fusing Belt Smoothing Roller Contact Sensor	9	Cleaning Web End Sensor
5	Fusing Belt Smoothing Roller Contact Motor	10	Cleaning Web Contact Sensor

## 13.2 DETAIL

### 13.2.1 FUSING MECHANISM

a) Belt fusing is adopted in this machine.

b) The surface of the fusing belt is made from polyimide and is covered by silicone rubber that is coated by teflon.

The fusing belt is driven by the fusing roller (Φ52).

#### Fusing roller material

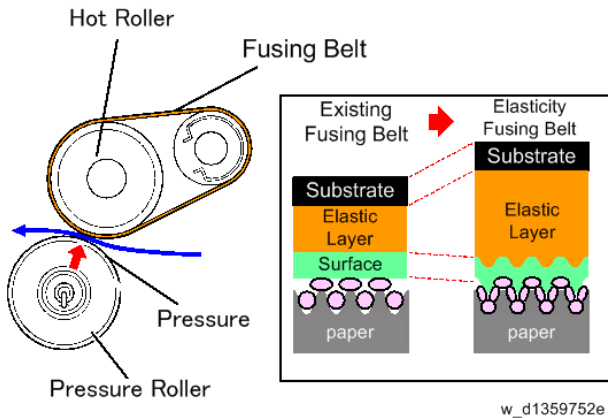

- MP C6502SP/MP C8002SP: Sponge rubber
- Pro C5100S/Pro C5110S: Solid rubber

The elastic layer of the fusing belt is thickened in order to let the belt enter indentations in the paper that existing belts cannot be inserted into. This improved fusing belt imposes pressure and heat equally on all parts of the paper, and dramatically enhances fusing efficiency.

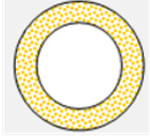

c) Hot Roller

In this machine, the hot roller materials are different between ProC5110S/5100S and MPC7002SP/6502SP in order to suit different type users as follows;

Machine Type	RICOH MP C6502SP/MP C8002SP	RICOH Pro C5100S/Pro C5110S	RICOH Pro C751EX/C651EX
Diagram	 d1355185 Silicone foam rollerφ50	 d1355182 Silicone solid rollerφ50	 d1355109 Silicone solid rollerφ54
Material	Employed for energy saving improvement <b>Merits</b> Shorter warming-up time (less than 60 sec) → Available when the roller surface is hot enough	Employed for image quality and productivity improvement <b>Merits</b> • Superior to MP C6502SP/MP C8002SP in printing on matt coated paper • Supports up to 150gsm → Employs a solid roller as RICOH Pro C751EX does in order to sustain nip and pressure longer	

	<b>Demerits</b> <ul style="list-style-type: none"> <li>▪ Lower image quality (for matt paper) than Pro</li> <li>• Lower productivity than Pro</li> <li>• MP C6502SP: 127.4gsm/MP</li> <li>• C8002SP: 100.9gsm</li> </ul>	<b>Demerits</b> <p>Longer warming-up time (less than 300sec)  → It is necessary to wait until the radius of the hot roller becomes steady</p>
Configuration	To improve separation for thin paper, the roller is smaller than that of RICOH Pro C751EX/C651EX	

**Comment [オプライエン50]:** Means a) must wait until the entire thickness of the roller is hot enough b) The size of the roller stops changing

RE:

I cannot make sure with the Japanese original, but I think the former - a) must wait until the entire thickness of the roller is hot enough - is right.  
12/6

#### d) Heating roller

The heating roller (Φ35) is made of a magnetic shunt alloy. The flux shield plate (aluminum) and the axis (aluminum) are included in the roller.

#### e) IH Coil (external heating IH)

In this machine, the IH coil heats the heating roller and the fusing belt.

The IH coil is employed in order to realize heat fast-increment and temperature uniformity.

#### f) Pressure Roller (Φ50)

The pressure roller (Φ50) surface is made of iron covered with silicone rubber that is coated with a teflon tube. The pressure roller has a fusing lamp in it.

### 13.2.2 THERMAL CONTROL

◆ **Thermal Control Sensors**

This machine has thermal control sensors that monitor each location to control the fusing lamp in order to keep the proper temperature.

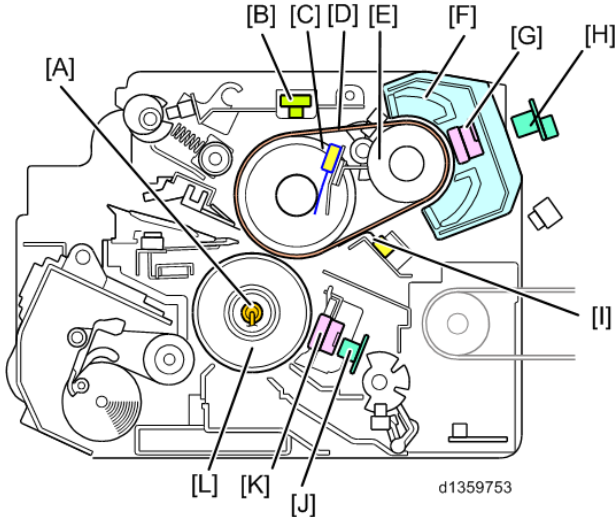

Thermal Control Sensor	Monitoring Area
Thermopile [H]	Heating Roller (Center)
Thermistor [I]	Fusing Belt (End)
NC Sensor [B]	Hot Roller (Between center and end)
Thermistor [C]	Hot Roller (End – Axis)
Thermopile [J]	Pressure Roller (Center)

◆ **Thermal Transition**

This machine controls the fusing unit to change the temperature in the fusing unit, depending on the eight states listed below:

Comment [n 51]: 3/12 throughout changed

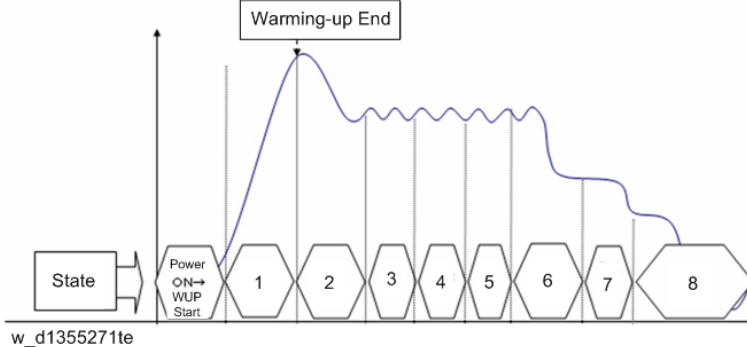

State	Descriptions
53. Start-up, Restart-up	The machine detects that all covers (doors) are closed and then starts the fusing warming-up. The machine controls the fusing motor, the IH heater, and the pressure roller fusing lamp to increase the fusing temperature up to the target temperature.

State	Descriptions
54. Rotation after Reload	After fusing warming-up finishes, the fusing motor turns on for a certain time to keep the fusing temperature at a specified level (adjusted with "SP1107-001: Heating R", "SP1107-002: Pressure R").
55. Before Paper Passing	The machine increases the temperature of the hot roller and of the pressure roller to reach "Paper Passing-start Temperature".
56. While Paper Passing	While paper is passing through the machine.
57. After Paper Passing	After the last sheet of a job passes the fusing exit sensor, the machine controls the fusing motor, IH heater, and the pressure roller fusing lamp to keep the target temperature (target temperature is adjusted with "SP1108-001: Heating R", "SP1108-002: Pressure R").
58. Ready	When the "After Paper Passing" state finishes, the machine turns to the "Ready" state. The machine controls the fusing motor, the IH heater, and the pressure roller fusing lamp in order to maintain the fusing temperature (can be adjusted with "SP1107-001: Heating R", "SP1107-002: Pressure R")
59. Low Power Mode	A specified time passes after fusing reload, and then the IH heater and fusing motor turn off. At the same time, the pressure roller fusing lamp turns on in order to keep the target temperature (can be adjusted with "SP1107-006") of the pressure roller.
60. Sleep Mode	A specified time (normal: 1 minute) passes after the machine turns to the "ready" state, and then the machine cuts power supply for the IH heater, the pressure roller fusing lamp, and the fusing motor.

### 13.2.3 FUSING ANTI-OVERHEAT

As an anti-overheat in the fusing unit, this machine has 3 step preventions (soft-overheat detection, hard-overheat detection, thermostat)

\*The component call-outs are corresponded with the diagram below.

	Heating Roller	Hot Roller	Pressure Roller
Soft-overheat Detection	For all types machine <SC543-00> Name: Thermopile [H] Detection Temp.: More than 240°C <SC563-00> Name: Thermistor [I] Detection Temp.: More than 250°C	For all types machine <SC577-00> Name: NC Sensor [B] Detection Temp.: 250°C	For all types machine <SC553-00> Name: Thermopile [J] Detection Temp.: More than 220°C
Hard-overheat Detection	For all types machine <SC544-00> Name: Thermopile [H] Detection Temp.: More than 250°C <SC564-00> Name: Thermistor [I] Detection Temp.: More than 260°C	For all types machine No Detection	For all types machine <SC554-00> Name: Thermopile [J] Detection Temp.: More than 250°C
Thermostat	If a thermostat has worked, replace the entire fusing unit. It's possible that the IH coil [F] / the fusing belt [D] / the heating roller [E] / the hot roller [C] / the pressure roller [L] are damaged.		

**Comment [オブライエン52]:** For each component (thermopile, thermistor, etc) is it possible to say which one in the diagram in the Thermal Control section

RE: 12/18

I gave call-outs to the diagram in the Thermal Control section. And also added the diagram in this section below.

12/19

Thanks, but sometimes the table contains words like 'Thermo Sensor NC-F10'. I hope to use the correct sensor names (as in your diagram) for all the sensors in this table.

RE: 12/19

I renamed and related the components in the list with the diagram below.

**Related Components Location Diagram**

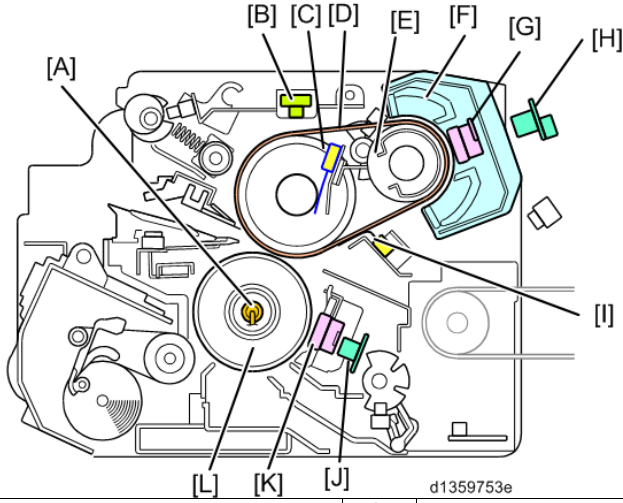

d1359753e

A	Pressure Fusing Lamp	G	Thermostat (For Heating Roller)
B	NC Sensor	H	Thermopile (For Heating Roller)
C	Thermistor (Hot Roller Axis) [Pro only]	I	Thermistor (Fusing Belt)
D	Fusing Belt	J	Thermopile (For Pressure Roller)
E	Heating Roller	K	Thermostat (For Pressure Roller)
F	IH Coil	L	Pressure Roller

### 13.2.4 FUSING DRIVE

Through gears, the fusing motor [C] drives the pressure roller [B] that rotates the hot roller [A] only when the hot roller [A] and the pressure roller [B] separate from each other.

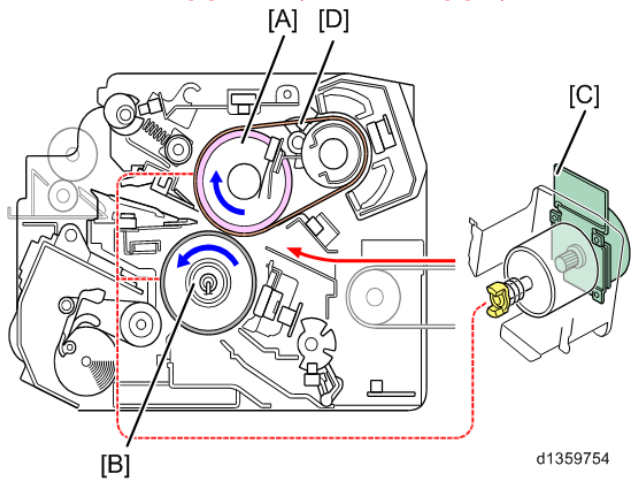

### 13.2.5 ROTATION DETECTION

Heating roller rotation sensor [A] detects the rotation of the fusing belt in order to feed back to the fusing motor. Heating roller rotation sensor prevents too much heating by the IH heater that can cause fire damage or breaking the machine down.

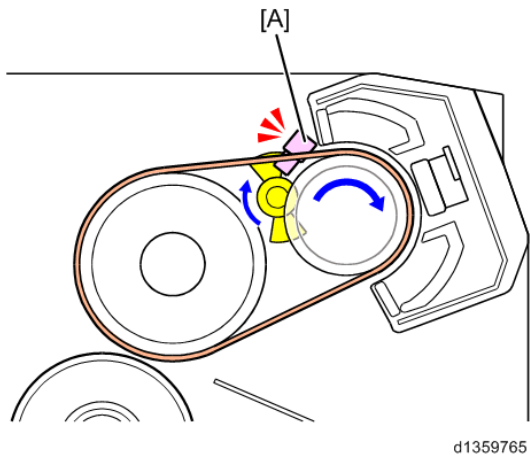

### 13.2.6 PRESSURE MECHANISM

The pressure roller has a release control mechanism to release fusing pressure when a job is not in progress. This contributes to reducing deformation of the pressure roller. In addition, the nip pressure is adjustable in 3 steps by changing the angle of the cam, depending on thickness of paper.

	State	Default Value
Pressure Position 0	Released	-
Pressure Position 1	The fusing drive motor drives in reverse to remove jammed paper (unchangeable in SP mode)	2mm
Pressure Position 2	For Envelop Passing (changeable in SP mode)	5mm
Pressure Position 3	For Paper Passing (unchangeable in SP mode)	14±0.3mm (Office) 14.7±0.3mm (Pro)

When a job starts, the fusing contact motor [A] drives, the pressure cam [B] turns, and the pressure roller unit [C] shifts up.

When a job finishes, the fusing contact motor [A] drives in the opposite direction, and the pressure roller unit [C] shifts down and pressure is released.

With the actuators [D], the front and rear sensors near the axial points of the cam detect the following:

- Pressure Roller Sensor (Front): Detects the angle of the cam in 3 steps to control the nip pressure
- Pressure Roller Sensor (Rear): Detects **HP**

The fusing contact motor [A] is driven by a DC brushless motor with an encoder. After the motor has applied pressure, it stays on because otherwise the roller rotation while paper is passing would tend to release the pressure.

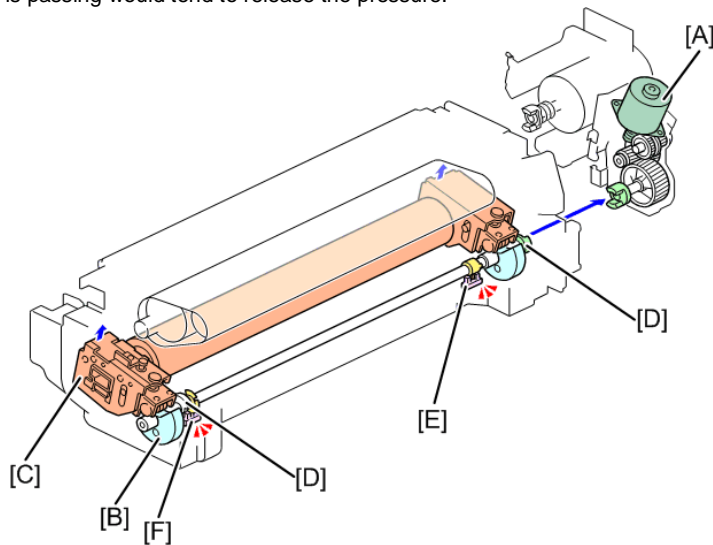

d1359755

**Comment [オブライエン53]:** 12/17:I think the yellow disks in the diagram below are the actuators for the sensors.

RE: 12/18

I thought all things which interrupt a sensor is called feeler.

Thanks to your pointing out.

12/19

It is OK to say feeler for a part that touches the paper for example, but the part that interacts with the sensor should be an actuator.

**Comment [オブライエン54]:** Sensor names: I called them fusing pressure sensors (front, rear) in the TTP

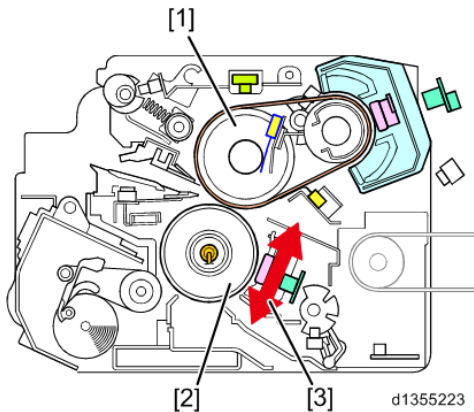

- 61. Hot Roller
- 62. Pressure Roller
- 63. Nip-band Change (by pressure position change)

### 13.2.7 FUSING NIP-BAND ADJUSTMENT (ENVELOPE)

In this machine, if you choose the followings to prevent the crease on envelope passing:

- “Envelope” in “Paper Thickness Setting”
- “Envelope” in “IMSS Paper Library” (ProC5100S/5110S only)

The pressure position 2 (envelope position) is selected automatically as a nip-band so that the nip-band on envelope printing becomes narrower in order to reduce the nip-pressure. By controlling the rotation-stop location of the fusing pressure motor, the stop-location of the pressure lever is changed to control the pressure strength of the pressure roller and the hot roller.

### 13.2.8 JAM DETECTION

The fusing exit sensor [A] that is installed in the fusing belt exit detects jams by monitoring the ejected paper.

The paper remaining sensor [B] that locates near the fusing entrance detects paper remaining in the fusing area after a jam occurs.

In normal printing, it doesn't function as a transport sensor.

If the paper remaining sensor [B] has been wrong and you replace it, do the following initial procedures:

64. Make sure that remaining paper doesn't exist on the optical path (arrow from the sensor) of the paper remaining sensor [B].
65. Close Drawer Unit and the Right Cover.
66. Do the "SP1-134-001".
67. Make sure that the value is 200~400 in "SP1-134-002" 200~400.
68. Reboot the machine

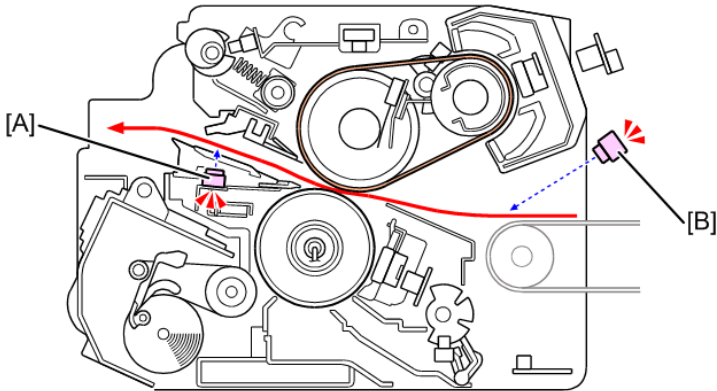

d1359756

### 13.2.9 CLEANING MECHANISM (CH-C1 PRO ONLY)

The Pro type has the cleaning web as C901 or C751EX series have. Taint attached on the fusing belt is cleaned indirectly by the cleaning web unit [B] through the pressure roller [A], in order to prevent tainted print (black spot).

The cleaning unit [B] removes dirt from the fusing belt through the pressure roller [A]. The cleaning web method (heatproof non-woven fabric) is adopted in the cleaning unit [B]. The cleaning web contacts the pressure roller [A] and wipes off toner and paper dust on the roller's surface while being rolled up by the web take-up roller [C]. The cleaning web [D] contains silicone oil in order to lubricate the pressure roller and the fusing belt. The cleaning web is driven by the fusing cleaning web motor [E], which turns on every time a certain number of sheets are printed in a job, and rolls up a certain length of the cleaning web. The web take-up roller [C] rolls up the used web.

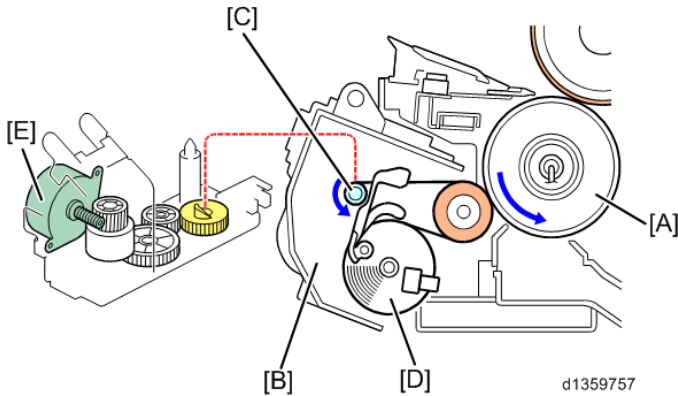

- Web Near-End**  
 When the cleaning web consumption reaches the setting in SP1902-004, the operation panel shows "Web Near-End". The default (81%) in the SP means the web lasts for approximately 450k prints.
- Web End**  
 The cleaning web unit has the actuator [A]. As the web take-up roller [B] rolls the used web up, the actuator [A] shifts down. When the web is all used up, the web end sensor [C] detects the actuator [A]. The machine stops printing after this is detected.

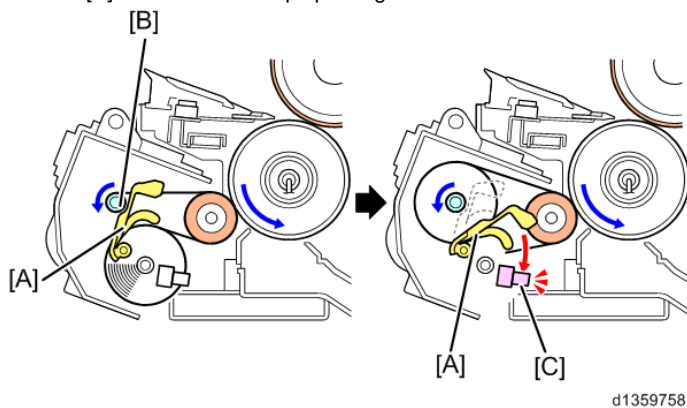

- **Cleaning Web Sensor**

The cleaning web unit set sensor [A] detects whether the cleaning web unit exists or not. The cleaning web contact motor [B] rotates the axis on which two disks [C] are attached. The disks [C] push up the cleaning web roller unit to make the cleaning web roller [D] contact on the pressure roller. At this time, the cleaning web contact / separation sensor [E] detects the actuator [F] on the axis and judges that the web cleaning roller contacts the pressure roller..

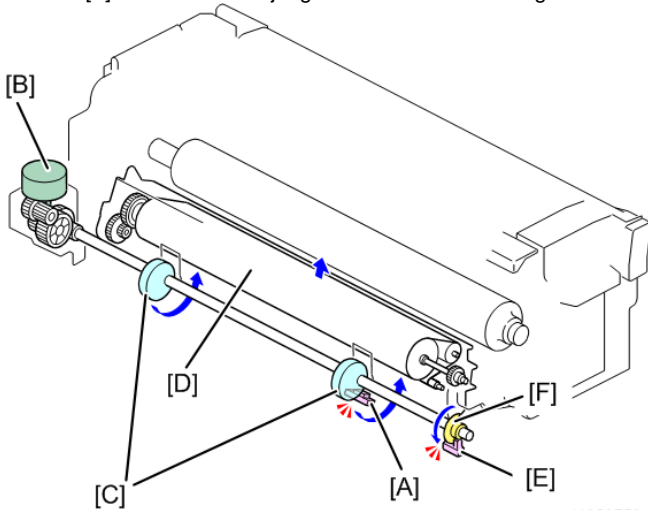

d1359759e

- **Counter Measure for Cleaning Web Jam**

In the pro C5100S series, when small size paper jams, the pressure roller [A] drives in reverse so the machine can detect the remaining paper. Then the remaining paper moves to an area where it can be removed easily.

But if the pressure roller [A] drives in reverse while the web [B] contacts it, the web can become wrapped around the roller. So to prevent it, the web separates from the pressure roller **when jam occurs**.

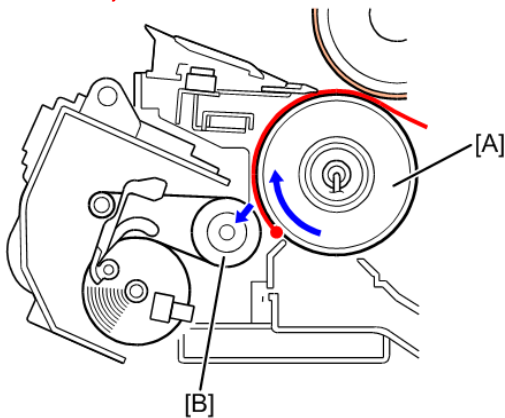

d1359760

### 13.2.10 FUSING BELT SMOOTHING ROLLER (CH-C1 PRO ONLY)

The fusing belt smoothing roller [A] is a countermeasure against damage to the belt caused by the edges of small sizes of thick paper.

The fusing belt smoothing roller [A] polishes the surface of the fusing belt [B] in order to remove roughness caused by paper edges and to prevent glossy streaks on prints.

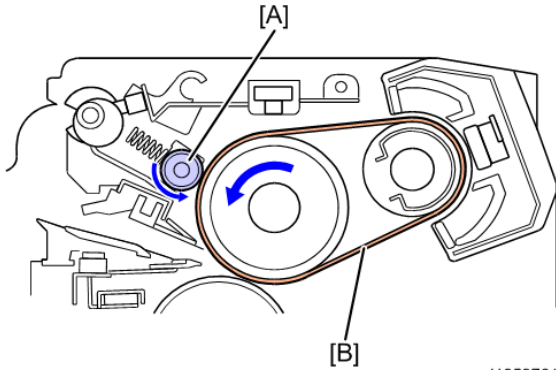

d1359761

#### ◆ Separation / contact

In the fusing belt smoothing roller operation, the fusing belt smoothing roller drive motor [A] drives the fusing belt smoothing roller. The fusing belt smoothing roller contacts on / separates from the fusing belt.

The refresh roller contact motor [B] rotates the cam [C] to move the fusing belt smoothing roller forward / backward. At this time, the contact sensor [D] detects the actuator [E] with which the cam [C] rotates.

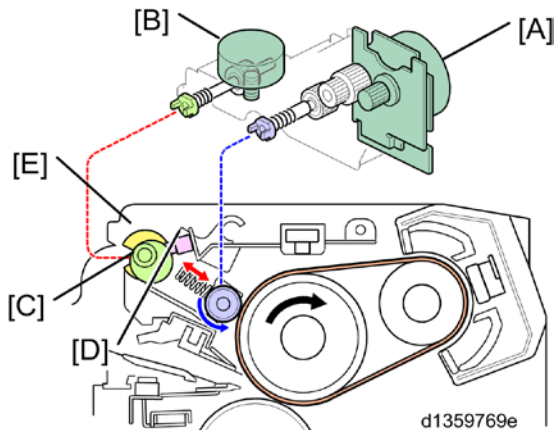

d1359769e

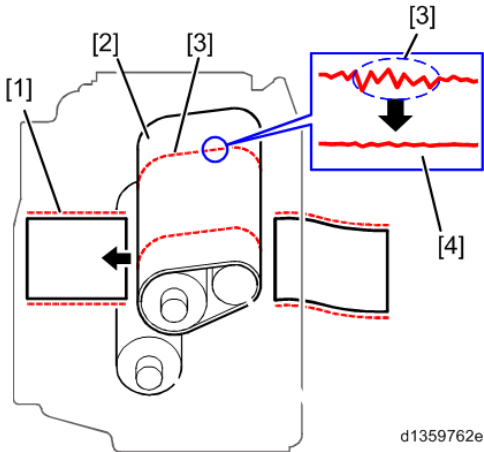

- 69. Paper Edge
- 70. Fusing Belt
- 71. Paper Edge Trace (roughness)
- 72. Polished Belt Surface with the fusing belt smoothing roller

**[How to use the fusing belt smoothing roller function]**

The fusing belt smoothing roller doesn't work automatically. Do "SP1133-110" or Special Operator Adjustment (0210-01). The specification is as below:

Item	Descriptions
SP Num.	SP 1133-110
Special Operator Num.	0210-01
Operator Num.	0210-01
Operation Specification	Roller rotates in 3 minutes in 1 cycle
Yield	180 minutes (60 cycles)
Near-End	Default 168 minutes (rest 6 cycles); modifiable in "SP1133-131"
End	Default 180 minutes : modifiable in "SP1133-132"
How to check the use rate	With the PM parts list shown on the operation panel display.

**Comment [ n 55]:** I don't know what this is like, but I heard that the refresh roller operation can be executed by an user operation on the panel.  
12/14  
12/17 - Looks like for trained operators (TCRU)

**Comment [オプライエン56]:** What does this mean? Looks like 4 cycles remaining (12 minutes)

RE: 12/18  
Certainly it's strange. But the original says "6" cycles.  
I think this is a mere mistake. As you say, it must be "rest 4 cycles".

**Comment [ n 57]:** I'm not sure about this. So we need to ask someone else to make sure.  
12/14  
12/17: Your explanation (PM parts list) sounds good, but of course, I don't know about this machine

**When you execute the fusing belt smoothing belt roller function more than three times in a row but no improvement appears, replace the fusing belt.**

### 13.2.11 FUSING HEAT-SHUTOUT / COOLING MECHANISM

#### ◆ Fusing Heat-shutout

To prevent the heat of the fusing unit from affecting the laser unit, this machine has cooling pipes. Five cooling pipes [G] are integrated in the aluminum panel. The cooling pipes reach the heat sink [B] that locates in the left-upper of the machine.

The heat pipe panel intake fan [A] cools down the heat sink [B] whose temperature rises up because of the circulation in the cooling pipes. The heat pipe panel exhaust fan [C] sucks the heat air out of the rear of the machine.

#### ◆ IH Coil Cooling

The IH coil cooling fan [F] that locates in the front side of the machine sucks in air to cool the IH coil (IH unit) [E]. The sucked air goes through the IH unit [E]. Then the transfer / fusing exhaust fan [D] sucks air out of the rear of the machine.

The transfer/fusing exhaust fan [D] also sucks out the heat around the PTR.

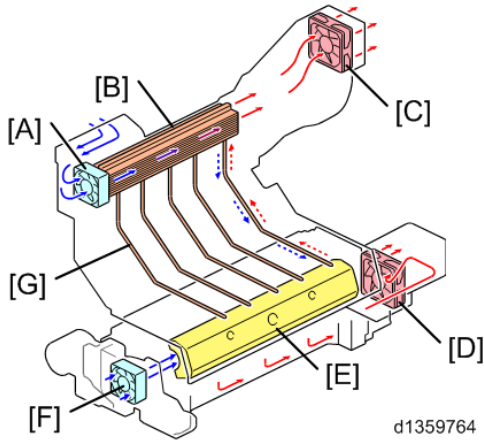

### 13.2.12 PRESSURE ROLLER COOLING (CH-C1 PRO ONLY)

The fusing pressure roller intake fan [A] sucks air out of the machine to makes air current under the pressure roller [C], in order to cool the pressure roller down. The fusing pressure roller exhaust fan [B] sucks air out of the rear of the machine.

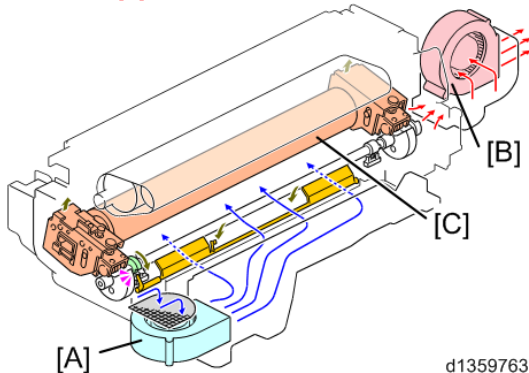

This mechanism prevents the pressure roller from increasing its temperature. This mechanism allows the machine to reduce the frequency of downtime due to the temperature increment of the pressure in consecutive print.

# 14. PAPER TRANSPORT BELT (PTB)

## 14.1 MECHANISM DESCRIPTIONS

### 14.1.1 LAYOUT

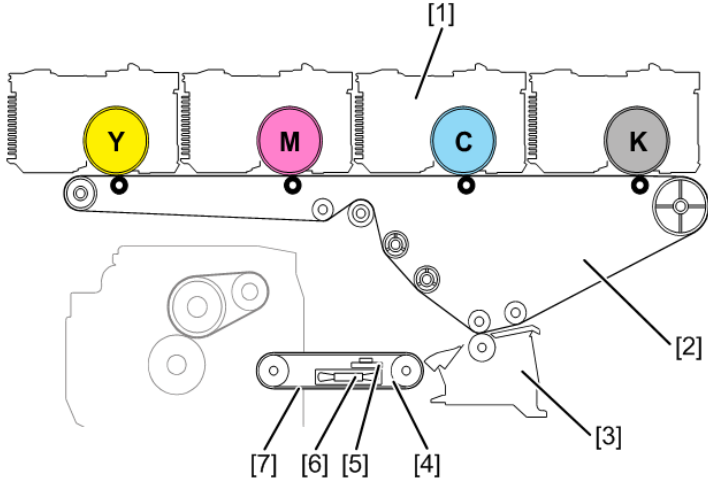

d1359701

1	PCU	5	Paper Transport Belt (PTB) Sensor
2	Image Transfer Belt (ITB) Unit	6	Paper Transport Belt (PTB) Fan
3	Paper Transfer Roller (PTR) Unit	7	Transport Belt
4	Paper Transport Belt (PTB) Unit		

### 14.1.2 TRANSPORT BELT MECHANISM

The PTR drive motor [B] drives the transport belt [A] through gears and the transport belt drive roller. The PTB fan [C] draws air in and exhausts it below through holes in the transport belt [A], in order to hold paper on the transport belt. In this way, paper is transferred to the fusing unit while keeping it on the transport belt [A]. In the PTB unit, the PTB sensor [D] detects paper jams.

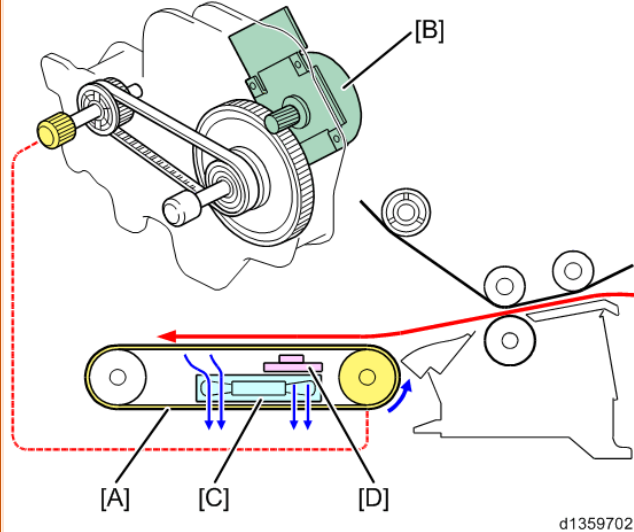

d1359702

**Comment [オブライエン59]:** 12/17 - I modified

**Comment [オブライエン60]:** Do you plan to add a description for d1359703?

RE: Yes, I'll add later.  
By the way, there seems to be a lot of descriptions I haven't written as like d1359703. And I know you have questions in the documents you have already checked.

I do want to ask you is which way do you prefer; I first answer your questions and then translate unfinished-part later, or I first translate unfinished-part and then answer your questions later?

I don't know which is the better way for your ttp writing work. So I would appreciate if you would tell me.

Thanks for asking –  
Answering my questions: I prefer to have answers as soon as possible, so that I can learn about the machine. But I think this way will disturb your translation work. So, please do as you like. Also please note that I send a list of questions to Mr Matsui and the other project leaders once a week, so they may also give me answers (they have to study the machine too, because they have to do training, so it is good for them). But if that is not good for you, it is better to answer my questions first. Anyway – its up to you.

**Comment [n 61]:** Thanks for your reply. OK then I'll answer some of the questions that you cannot make sense due to my English writing. And then I'll finish unfinished-parts. After that I'll answer the rest of your questions about contexts.

**Comment [n 62]:** Added 12/10

### 14.1.3 PTB TRANSPORT UNIT SET SENSOR

The PTB can be lowered by raising the lever [A] up, in order to facilitate a jam removal. (former model doesn't have this mechanism)  
The PTB unit set sensor [B] detects whether the PTB is seated on the operational position or not.

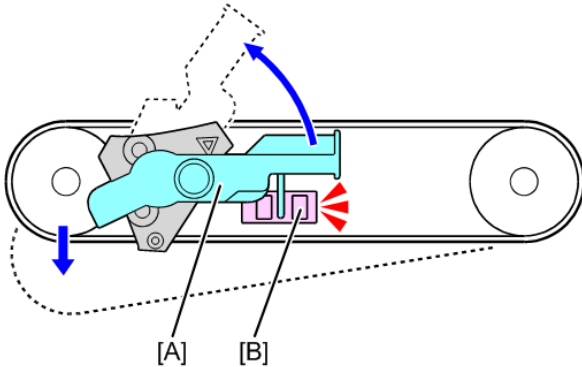

d1359703

## 15. PAPER FEED UNIT

### 15.1 MECHANISM DESCRIPTIONS

#### 15.1.1 LAYOUT

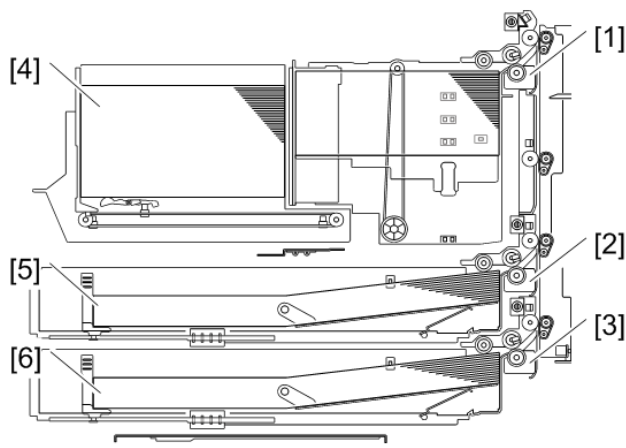

d1359631

1	1st Paper Feed Unit	4	1st Tray (Tandem Tray)
2	2nd Paper Feed Unit	5	2nd Tray
3	3rd Paper Feed Unit	6	3rd Tray

Feed / Separation	FRR method that has a press-release function, with a hysteretic maintenance-free torque limiter. Driven by a DC motor.
Tray Shift-up/down	A lift motor raises the bottom plate. The bottom plate drops under its own weight when the tray is pulled out of the copier because the coupling latch comes off.
Paper Size Auto-Detection	Using the end fence to detect the size. The paper thickness sensor detects the thickness of paper and overlapped paper (double feed).
Paper End Detection	Using the paper end sensor
Vertical Transport	Grip roller transport that is done with transport motors installed in each layer.

## 15.2 MECHANISM DETAILS

### 15.2.1 BANK

#### 73. Feed/Separation

The feed motor turns ON to drive the feed roller axis that drives the feed roller [A]. And through the relay belt, the pick-up roller [B] rotates to feed the top sheet of paper. And also through the belt, the separation axis rotates to drive the reverse roller [C]. The reverse roller [C] rotates in accordance with the feed roller [A] due to the friction power between the reverse roller [C] and the feed roller [A].

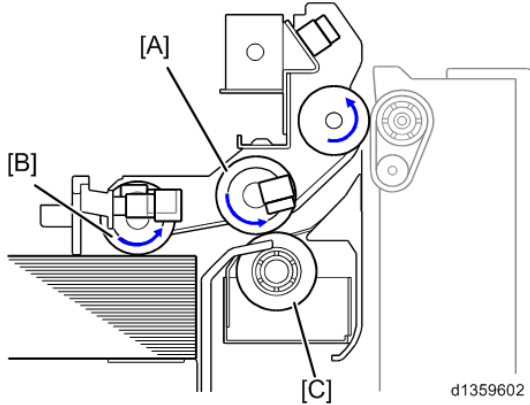

This friction power is stronger the limitation of the limiter. But when paper feed, more than two sheets of paper are fed, the limiter turns the direction of the rotation of the reverse roller [C] to push lower paper back to the tray. Fed paper is brought to the registration roller.

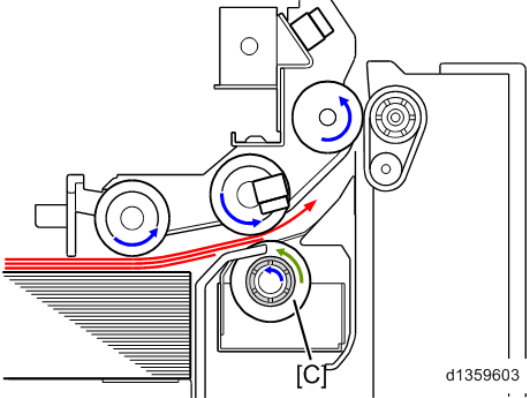

In a ready state, the feed motor [A] drives the feed roller [B], and then the axis of the reverse roller rotates to the arrowed direction.

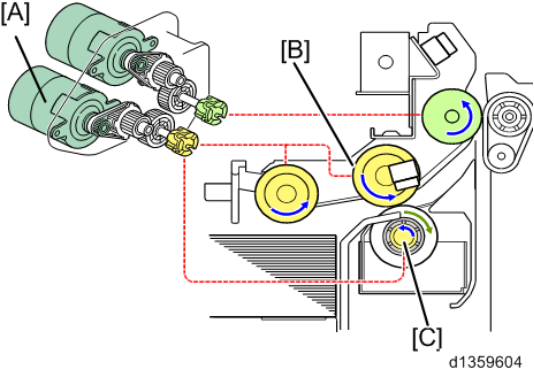

74. Reverse Roller Release

The reverse roller [B] is off from the feed roller [A]. The reverse roller [B] is pressed in paper when a paper feed tray placement.

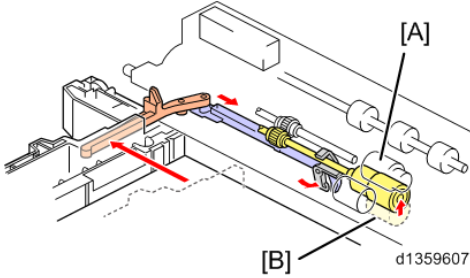

75. Tray Shift-up/down

a) With the rotation of the lift motor [A] located on the rear side, the coupling [B] latches on the pin [C] on the lift arm of the bottom plate [D] lifts. The latch with the coupling [B] and the pin [C] is released when the tray is withdrawn and the bottom plate downs under its own weight. The angle of the lift motor rotation affects the paper remaining level detection.

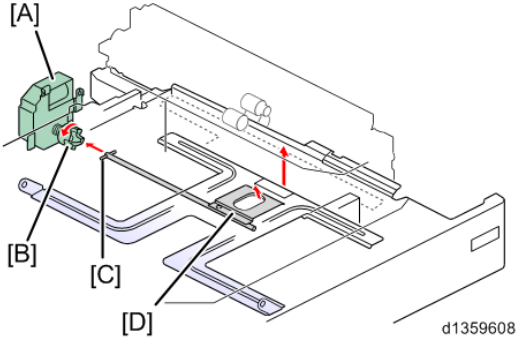

b) When feed tray placement, the pick-up roller [A] downs. In this time, the bottom plate lifts and the pick-up roller is lifted by the paper in the tray. And then the interrupting plate turns the lift sensor [C] OFF and the lift motor also turns OFF. As the level of paper in the tray downs and the sensor turns ON, the motor drives to lift the paper level [B] up.

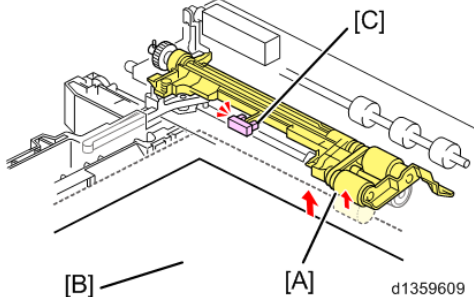

76. Paper End Detection

When run out of paper, the interrupting plate [A] turns the paper end sensor [B] ON and paper end detection occurs.

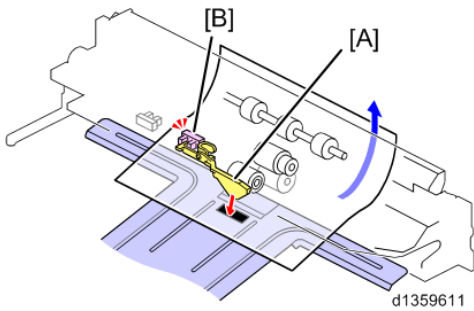

77. Tandem Tray (1st Tray)

a) Size Detection

The tandem feed tray cannot detect the size of paper. With the side and the back fence adjustment and SP mode, you can choose the size of paper. (Default: A4)

Comment [オフライン63]: Need to know the SP – I am sure we find out later

b) Tray Shift-up/down

The coupling [E] latches on the pin [B] on the lift axis of the bottom plate and the axis rotates when the lift motor [A] on the rear side of the tray drives. And then the timing pulley [C] rotates to roll up the timing belt and the bottom plate [D] lifts. The lift pin [B] that latches on the coupling of the lift motor is released when the tray is withdrawn, and the bottom plate drops down under its own weight. A damper is installed to prevent the plate from dropping intensely. The lift-up limitation detection is done by the lift sensor attached to the pick-up roller assembly unit, while the lower limitation detection is done by the sensor [F] on the rear side of the tray. The lift motor [A] drives and shifts the tray up/down.

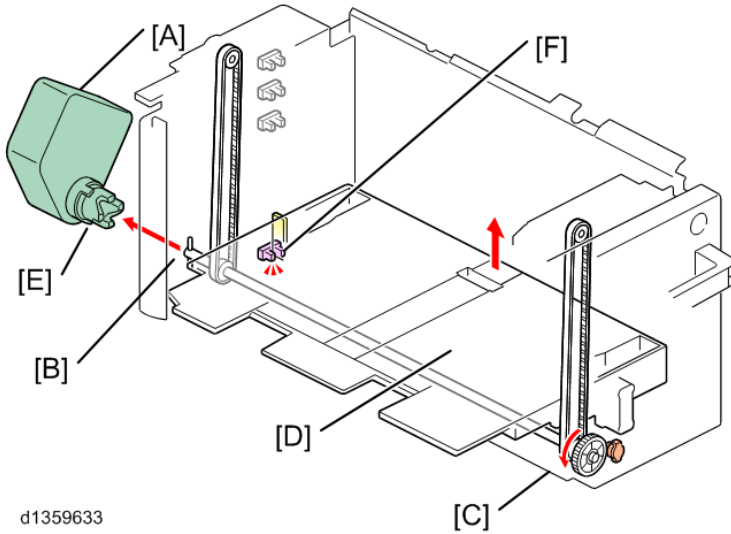

c) Paper Remaining Detection

The Four sensors [A] installed on the rear side of the bank detect paper remaining. After the lift motor [B] stops, the machine checks the near end, 10%, 30%, and 70% sensor in order. And then the operation panel shows paper remaining level that depends on which of the sensors is interrupted first. If none of them is detected as an interrupted sensor, the panel shows paper remaining level is 100%. Besides the paper end sensor judges wheter paper is remaining or not in the right tray.

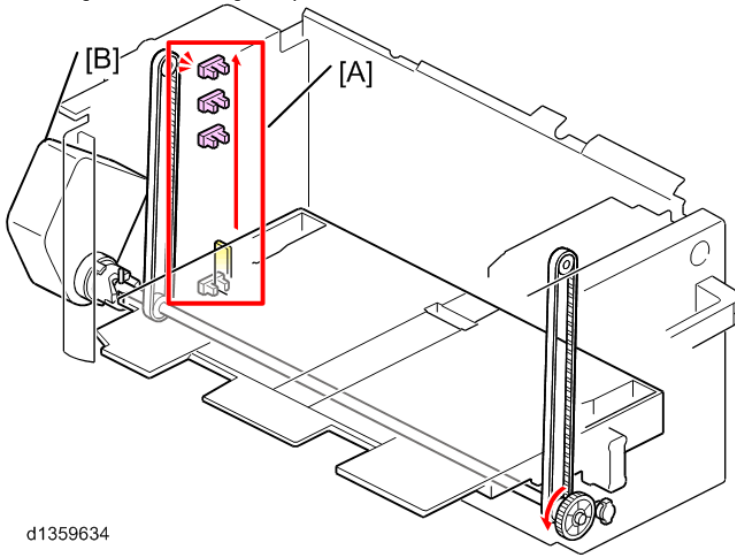

d1359634

**Comment [オブライエン64]:** Bottom sensor is lower limit sensor (see previous section)

Three pink sensors are 10, 30, 70%? Looks more like 10, 20, 30%

RE: 12/20/12

This is DOM values. So maybe these cannot apply to EXP machine. I cannot find the values for EXP. But in Taurus-C3, the values are Near-end, 25%, 50%, 75% (there are four sensors).

So I guess the values are near-end 75%, 50% (from upper to lower). But we need to ask someone else to make sure.

d) Right Tandem Tray End Fence Shift

The tandem tray has the rear end fence solenoid [A]. When paper runs out in the right tray, the solenoid [A] turns ON to operate the fence shift until the interruption against the end fence close sensor [B] is released. **When paper is moved from the left tray, the solenoid [A] turns ON in order to open the end fence [C] that is closed when the operation finishes.** The end fence close sensor [B] detects the open/closed of the end fence. **When the fence is not closed, the operation panel shows the request of placing stacked paper correctly in the tray.**

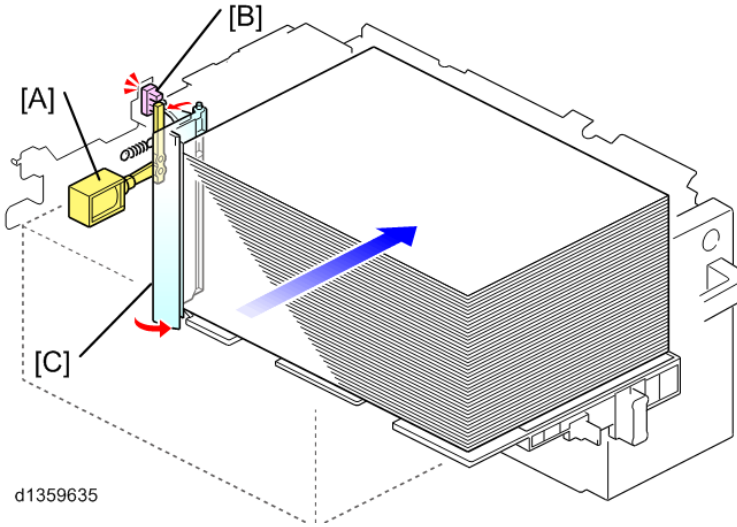

d1359635

**Comment [オフライン65]:** I don't understand this part well – replace what? User must do?

RE: 12/20  
I intended to mean “the request of closing the end fence”.

12/21 – sorry – I still don't get it – does the user have to close this fence?

RE: 12/25  
Actually, this request alerts an user to place stacked paper in the tray correctly. Because the fence cannot close due to stacked paper that prevents the fence from closing completely.

Certainly, I think this description is hard to understand. So I corrected.

e) Left Tandem Tray Back Fence Shift

When the paper end sensor in the right tray detects paper-runout while the paper detecting sensor [A] in the left tray judges that paper exists, the rear fence drive motor (DC motor) [B] turns ON at the same time of right end fence movement, and then the left tray back fence [C] moves to push stacked paper in the left tray to the right tray. When the left tray back fence [C] moves and the rear fence drive sensor [D] turns ON the rear fence drive motor starts to drive reversely. This operation stops when the paper push the home position sensor [E] turns ON.

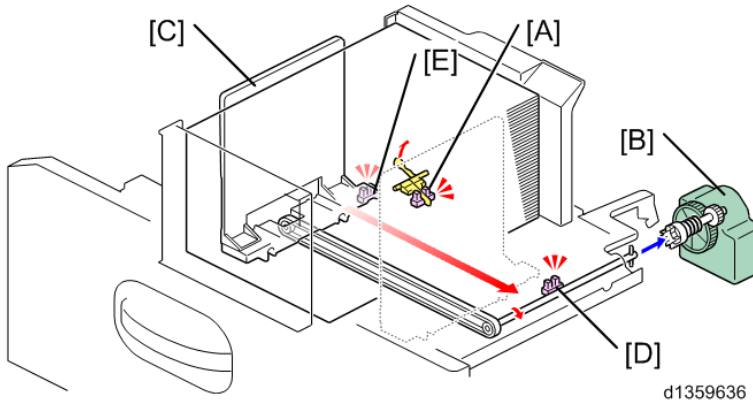

f) Left Tray Lock

The left tray cannot be withdrawn while paper is pushed from the left to the right tray. When paper push starts, the lock solenoid [A] turns ON and the lock latch [B] hooks on the rear convexed part [C] of the left tray. After paper push finishes and the tray back fence returns back to the home position, the lock solenoid [A] turns OFF and the latch [B] is released. This mechanism prevents withdrawing the tray while paper moves.

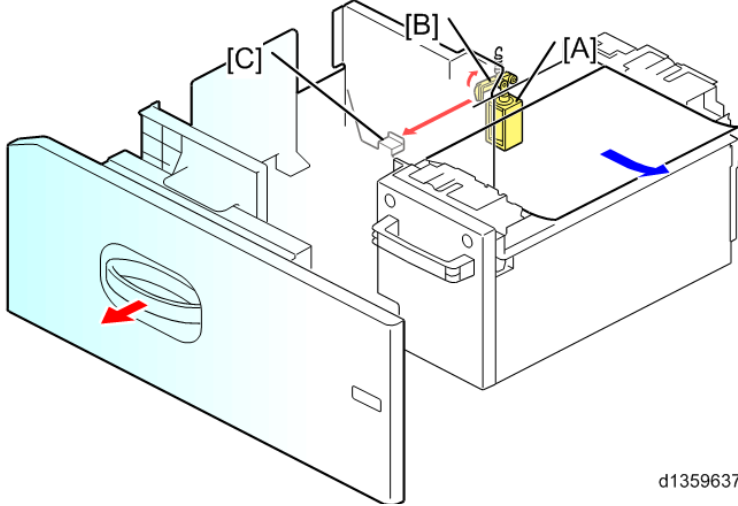

d1359637

**g) Right Tray Lock**

When the bottom plate is in the lowest position, the lock lever of the left tray latches on the joint lever [A] of the left tray and both of the trays are withdrawn at once. The joint lever [A] lifts itself due to its own weight, and the latch with the lock-lever is released. At this state, only the left tray can be withdrawn when the bottom plate is being lifted or is in the feed operation position. **The bottom plate [B] of the right tray lifts and the joint lever [A] lowers under its weight, and then the right tray is locked.**

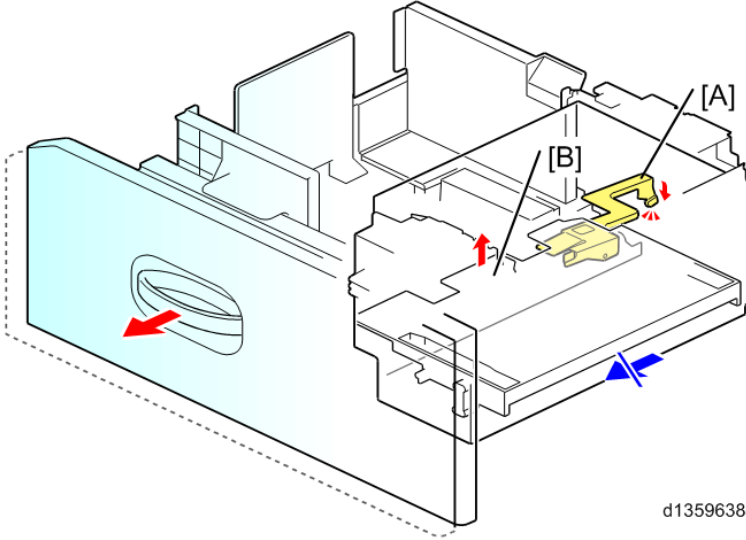

d1359638

**h) Tandem Operation**

When paper is in the left tray but the left tray paper end occurs while bottom plate lift or paper feed operation after the tray is closed, the machine operates as following below after the bottom plate in the right tray reaches the lowest position.

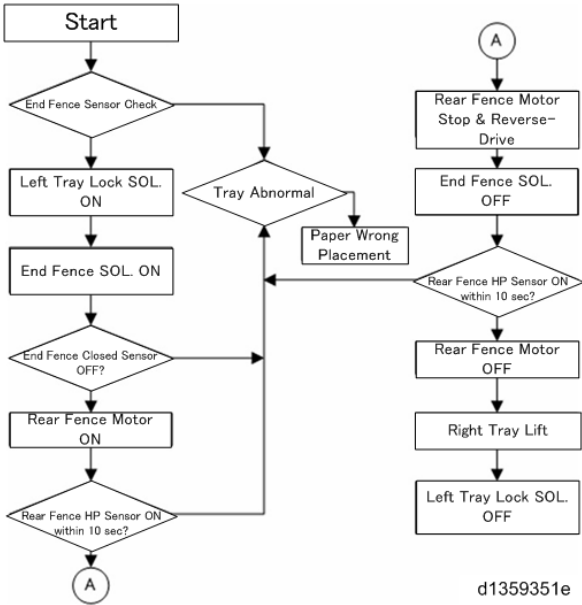

d1359351e

**Comment [ n 66]:** 2/19 translated

78. Dehumidification

As a dehumidification function for the bank unit, the dehumidification heaters [A] is available that can be installed under the 4th tray and 1st tray. **To use the heaters, connect the heater harness (simultaneously, the scanner anti-condensation heater and the LCT heater (for RT4020 / RT4030) also turn on if the machine has).**  
 In a factory shipment, the heater harnesses are not connected. (OFF)

**Comment [ n 67]:** 2/19(21)  
 \*Heater Specification changed (EXP only)  
 Former description is "the switch is needed to turn the heater on."  
 But now, "the heater turns on automatically when the harness is connected." (Diagram also changed)

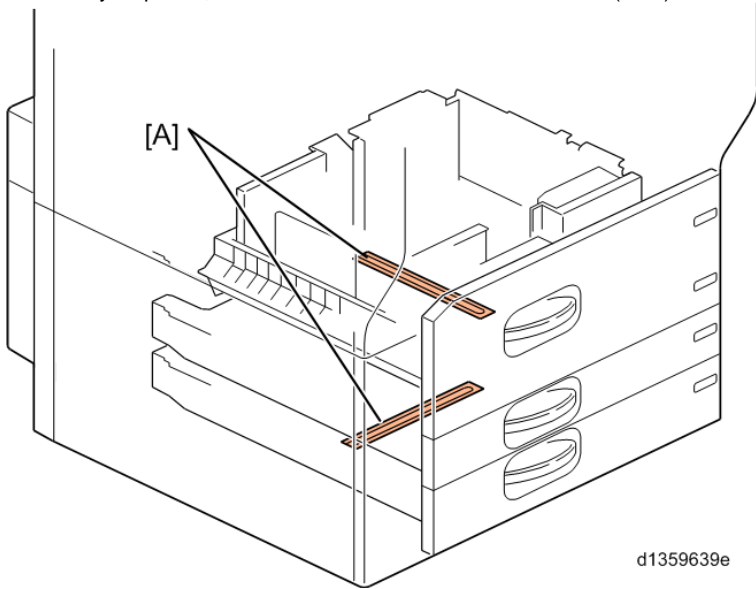

d1359639e

For details about connecting the heater harness, see the service manual (4: Replacement and Adjustment > Paper Feed Section (Tray 2 – 3 / Vertical Feed > Path) > Tray Heater Setting).

79. Papersize Auto-detection

The function in which user adjusts the side and the end fences for auto papersize detection is adopted in this machine. The side and end ones affect the 4-serial switch (bit combination) [A] and the machine detects the papersize to show it on the operation display. (The relation between the switch combination and the detected size is shown below.)

On the right rear side of the tray, the tray placement sensor SW [B] is installed.

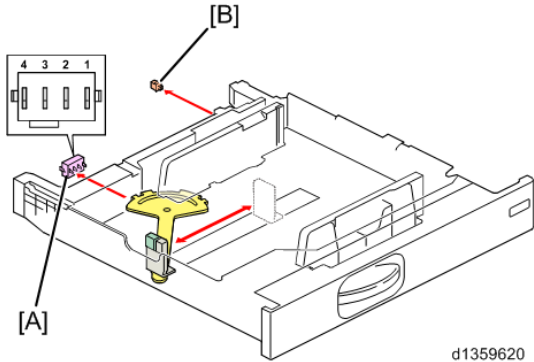

d1359620

0: Switch OFF (Sensor Output: H)  
1: Switch ON (Sensor Output: L)

Destination				Board Information			
DOM	NA	EU	ASIA	Knob 4	Knob 3	Knob 2	Knob 1
13"x19"	13"x19"	13"x19"	13"x19"	1	1	0	1
SRA3 (12"x18")	12"x18" (SRA3)	SRA3 (12"x18")	SRA3 (12"x18")	1	0	1	0
A3 (DLT)	DTL (A3)	A3 (DLT)	A3 (DLT)	0	1	0	0
B4 (LG)	LG (B4)	B4 (LG)	B4 (LG)	0	0	1	1
				0	1	1	1
A4_SEF	A4_SEF	A4_SEF	A4_SEF	1	1	1	0
LT_SEF	LT_SEF	LT_SEF	LT_SEF	1	1	0	0
B5_SEF	B5_SEF	B5_SEF	B5_SEF	1	0	0	0
A4_LEF (LT_LEF)	A4_LEF (LT_LEF)	A4_LEF (LT_LEF)	A4_LEF (LT_LEF)	0	0	0	1
B5_LEF (Exe_LEF)	B5_LEF (Exe_LEF)	B5_LEF (Exe_LEF)	B5_LEF (Exe_LEF)	0	0	1	0
A5_LEF (HLT_LEF)	A5_LEF (HLT_LEF)	A5_LEF (HLT_LEF)	A5_LEF (HLT_LEF)	0	1	0	1

15.2.2 TRAY PULL-IN / PULL-IN RELEASE

The pin [A] on the right rear side of a tray is pulled in by the pull-in lever in the lever unit [B] when a tray is placed, and the tray is pulled in. With a damper [C], the tray is pulled in softly. The release lever [D] is moved away from the machine's frame by pulling the handgrip [E].

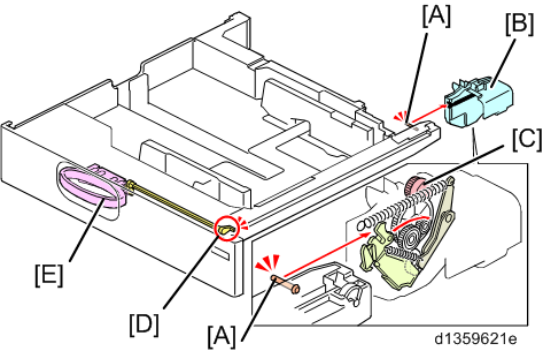

## 16. BYPASS

### 16.1 MECHANISM DESCRIPTIONS

#### 16.1.1 LAYOUT

◆ Office

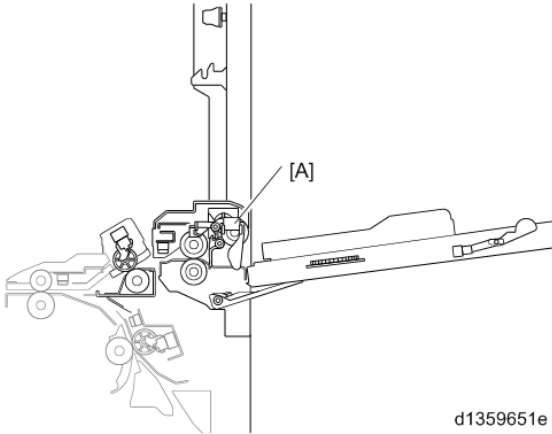

d1359651e

◆ Pro

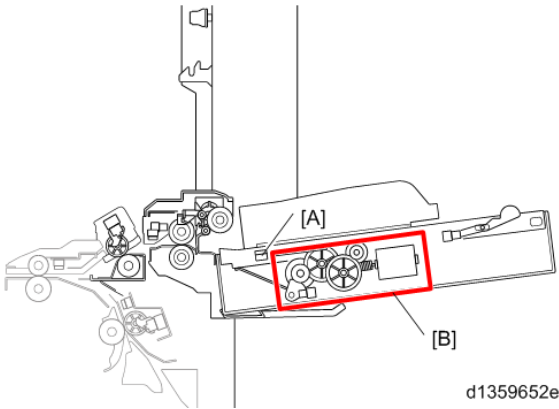

d1359652e

The differences between the Office and the Pro are;

- The location of the paper end sensor [A]
- In the Pro, the bottom plate lift mechanism is installed in the tray [B]

## 16.2 MECHANISM DETAILS

### 80. Bypass unit Open/Close

You can push the bypass lever [A] down to open the cover in which the bypass unit is integrated. This structure facilitates jam removal.

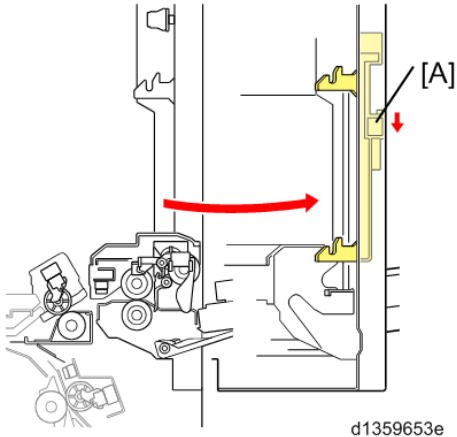

**81. Feed/Transport Drive**

There are two motors. One is the bypass motor [A] that drives the pick-up roller and the feed roller. The other is the bypass/relay transport motor [B] that drives the reverse roller and the relay roller.

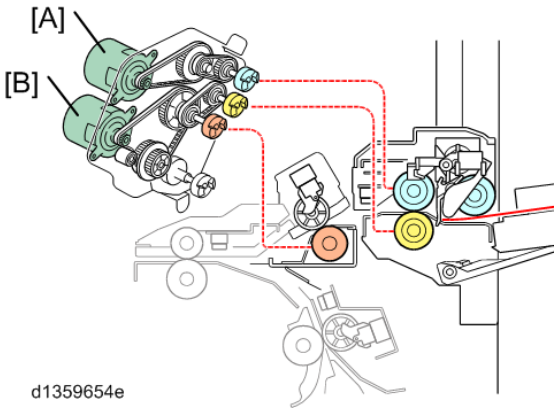

d1359654e

**82. Pick-up/Feed**

The FRR method is employed in this bypass unit. The pick-up roller [A] is shifted up/down by the solenoid [B]. When the solenoid [B] moves the pick-up roller [A] down, the solenoid moves the lever [C] that locks the paper stopper [D] (you cannot insert paper between the feed roller and the reverse roller in this state). This lock is released when the solenoid moves the pick-up roller [A] down in order to let the feed roller and the reverse roller feed paper.

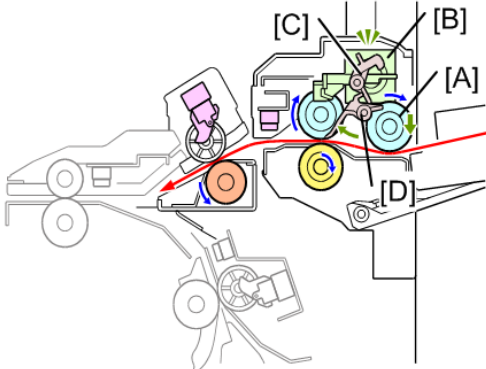

d1359655e

**Comment [オブライエン68]:** This mechanism is different from shown in Mr Nagao's drawings

RE: 12/26/12  
Yes, no clutch is in this bypass tray. I modified descriptions.

### 83. Bypass Paper End Detection MP6502SP/MP8002SP

The paper end sensor [A] has the feeler. When paper end, the feeler moves forward and its upper end interrupts the sensor.

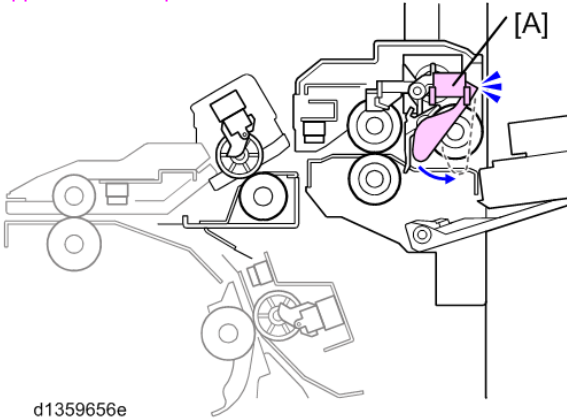

d1359656e

### Pro C5100S/Pro C5110S

The bypass bottom plate has a reflective photosensor [A] that is used for paper end detection. When paper is placed, the sensor turns ON (Interrupted). When paper end, the sensor turns OFF (not interrupted) and it means paper end.

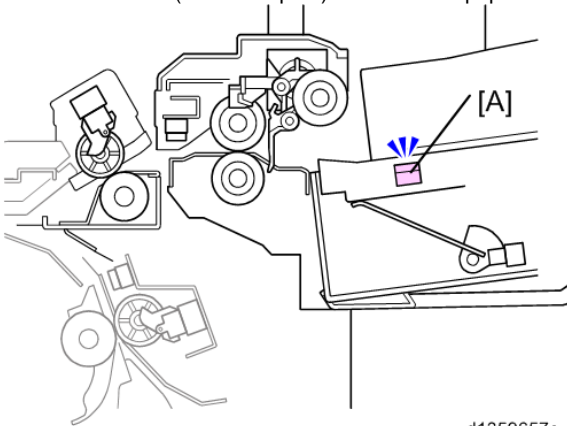

d1359657e

### 84. Size Detection

Paper size is detected by the bypass width switch [A] and the bypass length sensor [B]. There is no difference in the way of the detection between the Office and the Pro.

#### Office

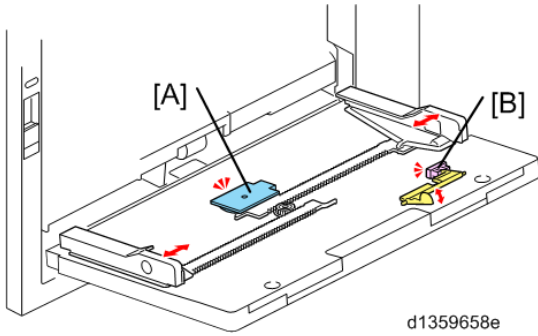

#### Pro

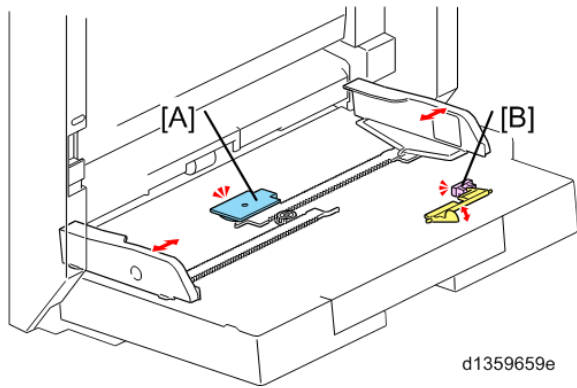

Detected Size			Sensor Output Signal					
DOM	NA	Except DOM/NA	Bypass Width Switch					Bypass Length Sensor
			CN1	CN2	CN3	CN4	CN5	ON:0 (Not interrupted) OFF:1 (interrupted)
Letter_SEF	HLT_SEF	A6_SEF	0	1	1	1	1	0 1
B6_SEF		B6_SEF	0	0	1	1	1	0 1
A5_SEF		A5_SEF	1	0	1	1	1	0 1
B5_SEF	LT_SEF/LG_SEF	B5_SEF	1	0	0	1	1	0 1
A4_SEF		A4_SEF	1	1	0	1	1	0 1
A5_LEF	HLT_LEF	A5_LEF						1
B4_SEF	DLT_SEF	B4_SEF	1	1	0	0	1	0
B5_LEF	LT_LEF	B5_LEF						0
A3_SEF	DLT_SEF	A3_SEF	1	1	0	0	0	1
A4_LEF	LT_LEF	A4_LEF						0
12"x18" _SEF			1	1	1	0	0	1
SRA3_SEF			1	1	1	0	1	0
13"x19" _SEF			1	1	1	0	1	1

**85. Bypass Bottom Plate Lift (Pro only)**

**Pro C5100S/Pro C5110S**

The bypass bottom plate lift sensor [A] is installed in the bypass roller unit. This sensor [A] detects the lift of the bottom plate [B] when the pick-up roller [C] is pushed up. The bottom plate HP sensor [D] is installed in the bypass tray, which detects the protrusion [E] on the backside of the bottom plate [B] when the bottom plate moves down to the home position. The lever (gear) [F] moves up/down the bottom plate [B]. The bottom plate motor [G] drives the lever [F] through the gears.

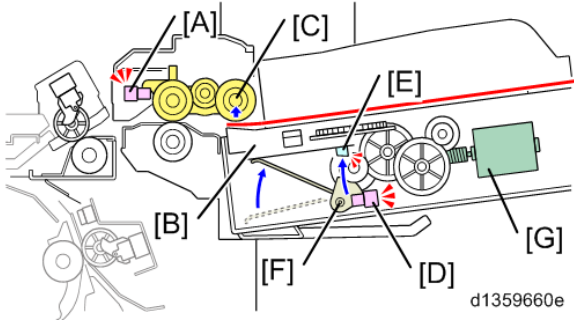

**Comment [オプライエン69]:** Sorry don't understand – Mr Nagaos explanation is also a bit complicated

RE: 12/26/12  
I modified whole descriptions.

# 17. VERTICAL TRANSPORT

## 17.1 MECHANISM DESCRIPTIONS

### 17.1.1 LAYOUT DIAGRAM

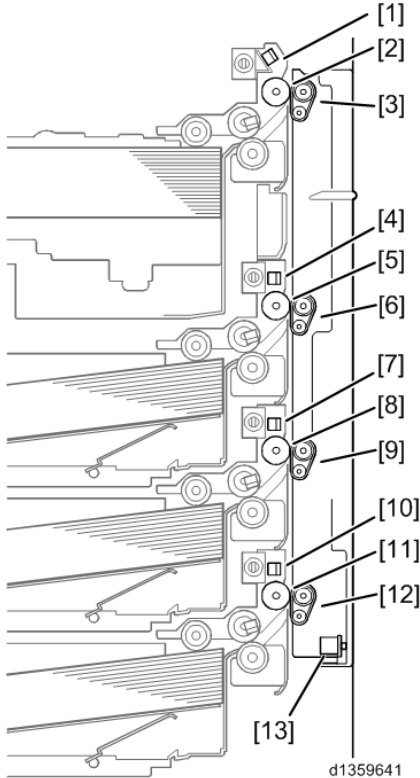

86. 1st Transport Sensor	93. 3rd Transport Roller
87. 1st Transport Roller	94. 3rd Driven Belt
88. 1st Driven Belt	95. 4th Transport Sensor
89. 2nd Transport Sensor	96. 4th Transport Roller
90. 2nd Transport Roller	97. 4th Driven Belt
91. 2nd Driven Belt	98. Vertical Transport Guide Cover SW
92. 3rd Transport Sensor	

## 17.2 MECHANISM DETAILS

### 99. Vertical Transport

The transfer part changes to an integrated part with the exterior cover, which makes it easier to remove jammed paper with opening the vertical transport guide cover [A].

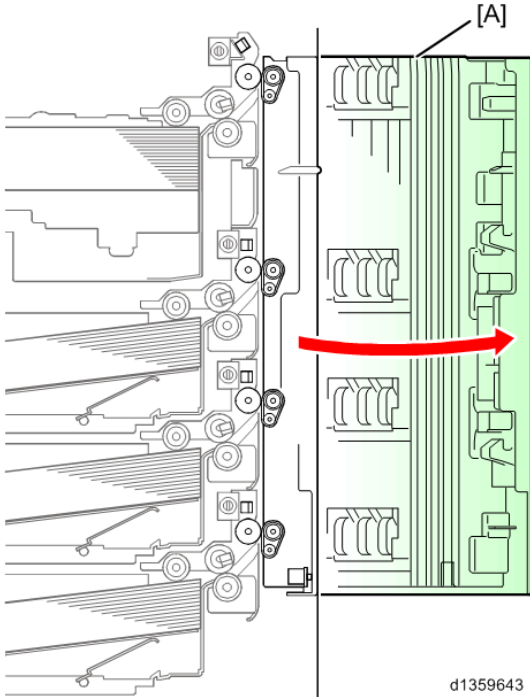

Each layer feed unit has transport rollers [A] that are assembled in the machine. The transport motor [C] drives the transfer roller axis. The vertical transfer door is supported with the support pin on which the door lever [D] latches when it closes. Each transport roller [A] has a driven belt [B] that is pressed on with the pressure spring.

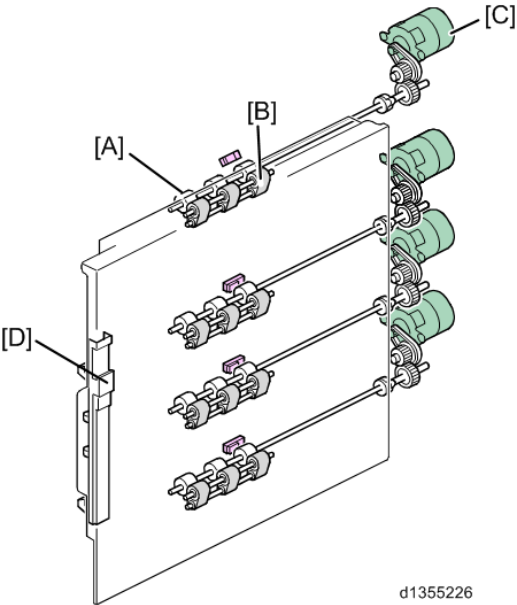

d1355226

## 18. PAPER REGISTRATION

**Comment [ n 70]:** 1/22  
Changed and added some pictures and descriptions.

### 18.1 GENERAL DESCRIPTIONS

#### 18.1.1 GENERAL LAYOUT

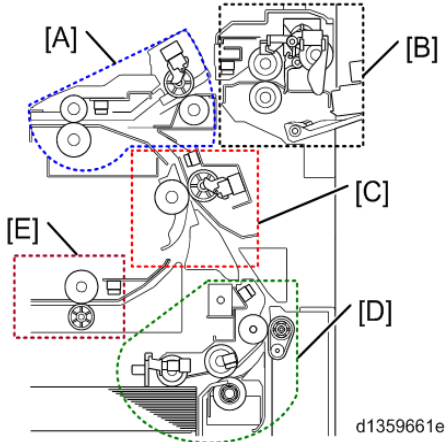

- A: Registration Part
- B: Bypass Part
- C: Relay Transport Part
- D: Paper Feed Part
- E: Horizontal Transport Part

#### 18.1.2 TRANSPORT PATH LAYOUT

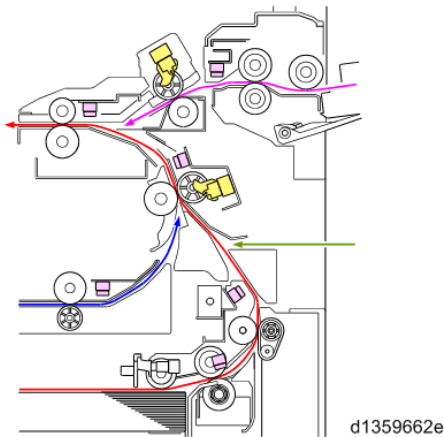

- Red: Main Tray Paper Path
- Green: Bypass Paper Path
- Pink: Option Tray Paper Path
- Blue: Duplex Paper Path (Horizontal Transport)

### 18.1.3 DRIVE LAYOUT

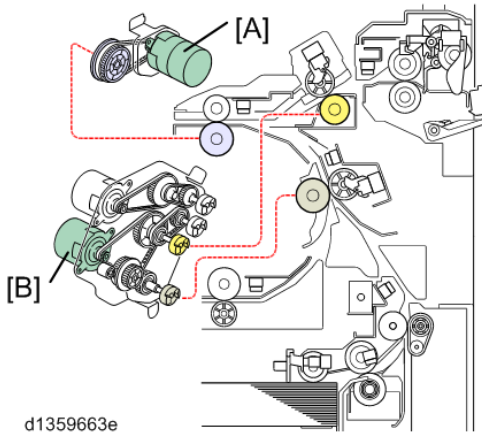

d1359663e

**A:** Registration Motor

**B:** Relay Transport Motor

## 18.2 MECHANISM DETAILS

### 18.2.1 REGISTRATION

#### ◆ Unit Components

Registration Transport	The machine guides paper to the registration from the bank, bypass and duplex part. The registration roller can turn noncontact state to ease jammed paper removal.
Paper Dust Collection	Paper dust collection mylar is installed to cover the full width of the registration roller.

#### ◆ Registration Transport

The registration separation lever [D] allows the registration rollers [B] [E] to contact/separate in order to facilitate a jam removal.

The registration sensor [A] detects the leading edge of paper and then the bypass motor turns off.

The registration rollers [B] [E] stop paper to align it and then the registration motor [C] drives the registration roller (lower) [E].

In this machine, by adding a motor only for the registration, this machine doesn't need to have a registration clutch that occurs shock jitter.

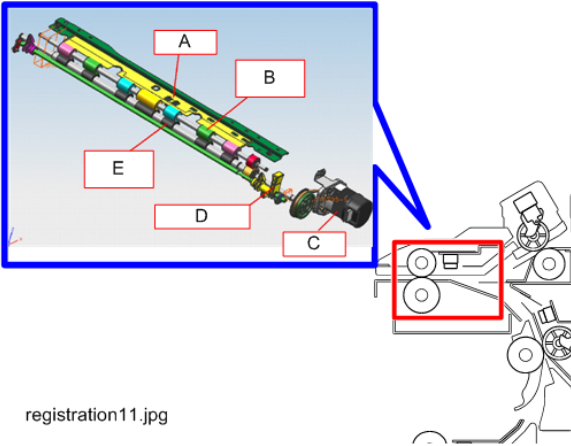

registration11.jpg

A	Registration Sensor
B	Registration Roller (upper)[driven]
C	Registration Motor
D	Registration Separation Lever
E	Registration Roller (lower)[drive]

#### ◆ Skew Correction

The skew correction in this machine is the same method as in [D081/D082](#).

Paper that passes up through the relay transport part bumps onto the registration rollers. At this time, slackness is made on paper, which lets the leading edge of paper sit parallel to the registration rollers. Without sufficient slackness, the correction cannot be applied to paper effectively.

You can adjust the amount of slackness by SP mode. (See the Service Manual "Troubleshooting > Adjustment005:Registration")

#### ◆ Lead-to-Lead Registration

To match the leading edge of an image and of paper, the registration roller stops in a specified time and then drives again to adjust the timing when to transport paper to the downstream section (transport timing). This process is the same as [D081/D082](#).

You can adjust the transport timing by SP mode. (See the Service Manual "Troubleshooting > Adjustment005:Registration")

Comment [ n 71]: 3/7 added

Comment [ n 72]: MPC6000/7000 (DOM)

Comment [ n 73]: MPC6000/7000 (DOM)

### ◆ Paper Dust Collection

The dust collection film [A] contacts the registration roller (upper) [B] in order to collect paper dust. This prevents involving paper dust in the following process.

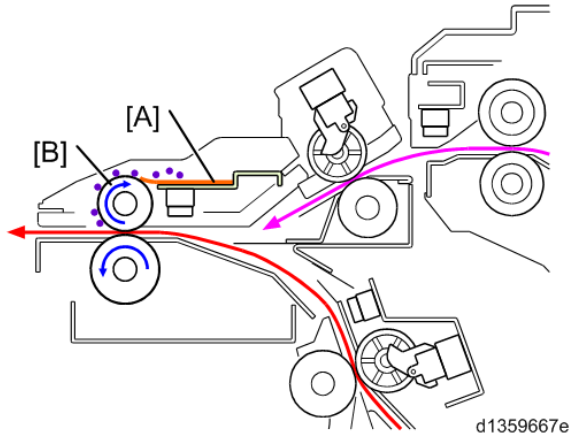

## 18.2.2 PAPER THICKNESS / DOUBLE FEED DETECTION

The proper condition on transfer and fusing varies depending on type and thickness of paper. So it's important to choose correct thickness in order to keep print quality. It's also important because a fusing detection and a jam may occur when the machine feeds paper whose thickness is different from its setting. To prevent troubles, this machine does the paper thickness/ double feed detection.

### ▪ Basic Operation

By using the thickness sensor (lever-type encoder sensor) [A] to measure and compare the thickness of transported paper, the machine detects "paper type difference" and "double feed" to stop paper transport operation.

\* Remaining paper in the machine is removed by the same way as the normal jam removal way.

Thicker paper pushes the thickness sensor largely as shown below.

[1]: When thin paper passes

[2]: When thick paper passes

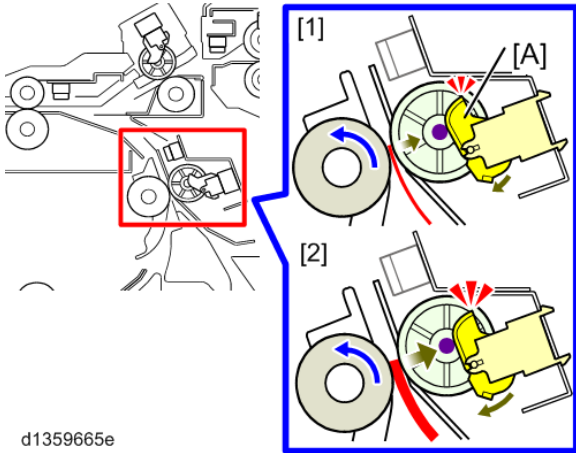

d1359665e

How degree the thickness lever moves is detected by the encoder [A] on the lever. With referring to the degree, the machine judges "paper type difference" and "double feed" to stop paper transport operation.

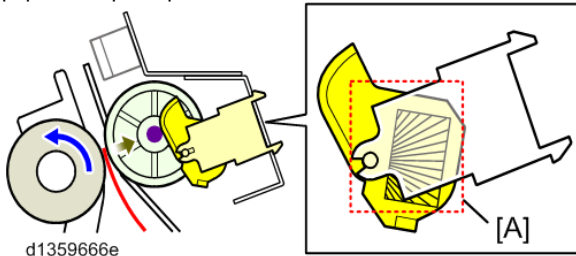

d1359666e

100. Thickness Detection

When 1st-paper reaches the thickness measurement part, the measurement in which the location of the driven roller decides the thickness is done. And then the measurement result and the thickness set-value are compared.

If the thickness is out of the range of the value, the machine judges as wrong-thickness paper and stops transfer operation. ("J098" displayed)

Alert		Paper Type Result							
		Thin	Plain 1	Plain 2	Middle Thick	Thick 1	Thick 2	Thick 3	Thick 4
Tray Setting	Thin	-				JAM	JAM	JAM	JAM
	Plain 1		-				JAM	JAM	JAM
	Plain 2			-				JAM	JAM
	Middle Thick				-				JAM
	Thick 1	JAM				-			
	Thick 2	JAM	JAM				-		
	Thick 3	JAM	JAM	JAM				-	
	Thick 4	JAM	JAM	JAM	JAM				-

Alert		Paper Thickness Result							
		Thickne ss 1	Thickne ss 2	Thickne ss 3	Thickne ss 4	Thickne ss 5	Thickne ss 6	Thickne ss 7	Thickne ss 8
Tray	Thickness	-				JAM	JAM	JAM	JAM

Setting	1								
	Thickness		-				JAM	JAM	JAM
	2								
	Thickness			-				JAM	JAM
	3								
	Thickness				-				JAM
	4								
	Thickness					-			
	5	JAM					-		
Thickness	JAM	JAM					-		
6	JAM	JAM	JAM					-	
Thickness	JAM	JAM	JAM						
7									
Thickness									
8									

## 101. Double Feed Detection

There are two types of double feed;

Precedence paper is double-fed, following paper is normal-fed: "J095"

Precedence paper is normal-fed, following paper is double-fed: "J099"

This machine compares former and later fed paper (2 sheets) from the same tray.

→If the thickness difference between the 2 sheets is larger than the threshold of double feed judge, double feed detection occurs and paper transport operation stops ("J095" or "J099" displayed).

The threshold can be set in "SP1304-001 to 016".

→Former thickness value is reset at the following conditions below;

1. Power source ON (All tray)
2. Tray placement (pulled-out tray only)
3. Bypass paper end switches from "paper end" to "paper exists" (bypass tray only)
4. First printing after paper type / thickness setting (setting-changed tray only)
5. Double feed (double feeding tray only)
6. Startup from energy saving mode

## 102. Note

a) With SP mode or System Initial Setting, you can turn "thickness detection" and "double feed detection" ON/OFF (Default: ON) resectively in each feed entrance.

b) The following paper types can be misdetected.

- Colored Paper
- Punched Paper
- Backed Paper
- Mixed-type Sheets of Paper

**Comment [オブライエン74]:** We need to know which Sps

RE: 12/20/12  
According to the SP database, It seems "SP1302-001 to 006".

001 - 004: Tray1 – Tray4  
005: LCT  
006: Bypass Tray

12/21  
Tray 4 is Japan only I guess

## 19. PAPER EXIT AND DUPLEXING

### 19.1 MECHANISM DESCRIPTIONS

#### 19.1.1 SECTION LAYOUT

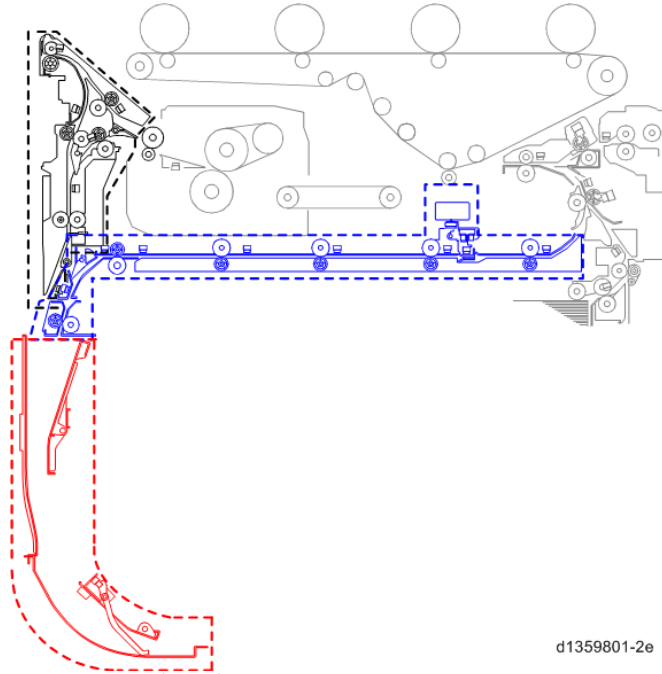

d1359801-2e

**Black:** Inverter / Exit Section

**Blue:** Duplex Path Section

**Red:** Purge Section

### 19.1.2 TRANSPORT PATH

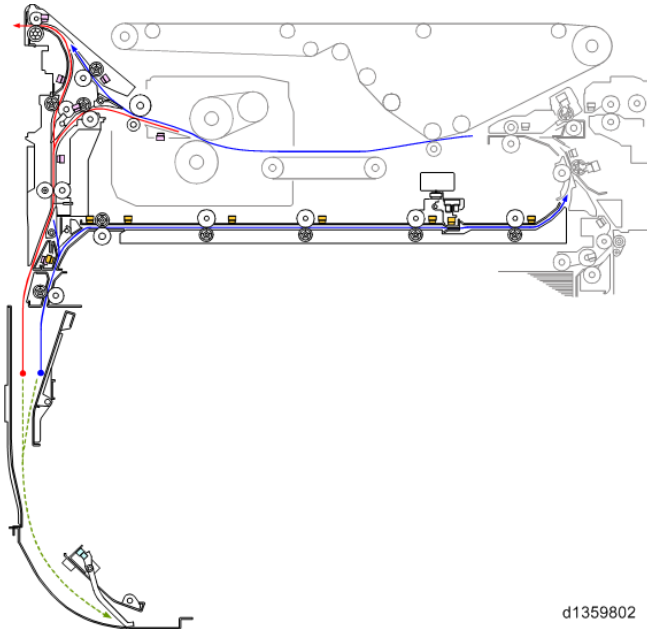

d1359802

**Red:** Inverter / Exit Paper Path (Face-down)  
**Blue:** Duplex Paper Path  
**Green:** Purge Paper Path

### 19.1.3 DRIVE LAYOUT

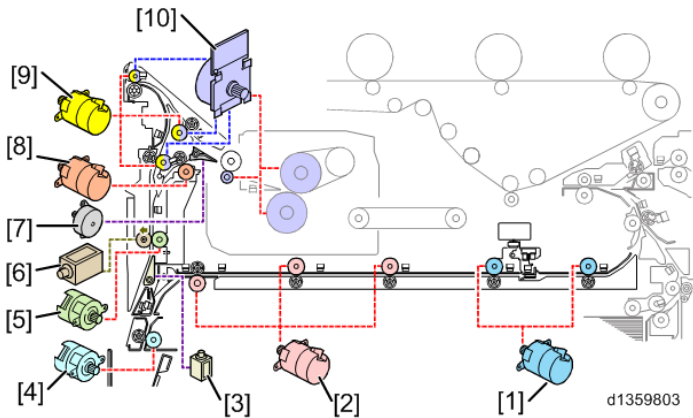

103. Inverter Exit Motor	108. Exit/Inverter Solenoid
104. Duplex Transport Motor	109. Inverter Entrance Junction Gate Motor
105. Duplex Inverter Solenoid	110. Inverter Entrance Motor
106. Duplex Inverter Motor	111. Exit Motor
107. Exit/Inverter Motor	112. Fusing Motor

## 19.2 MECHANISM DETAILS

### 19.2.1 SIDE-TO-SIDE REGISTRATION

In this machine, rollers in duplex paper path shift to perform side-to-side registration. After the leading edge of paper passes by the edge sensor unit [A], the edge sensor [B] that waits in the home position drives to the main-scan direction as the sensor shift motor [C] drives. And then the sensor detects the edge of paper.

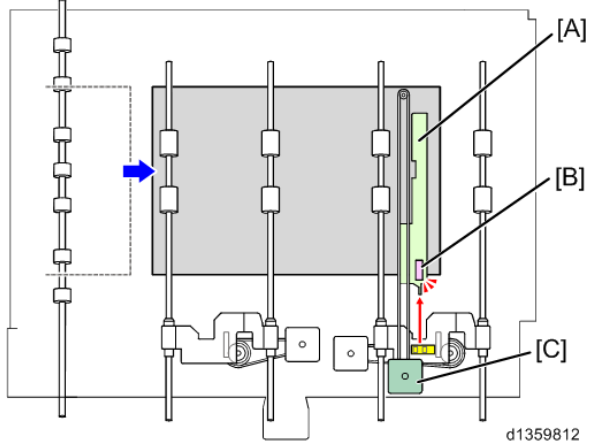

In case of paper that is less than 220mm feed-length (less than A4 LEF / LT LEF), after passing the leading edge of the paper by the duplex exit roller [G], the duplex transport roller 4 [F] and the duplex exit roller [G] shift to the main-scan direction according to the rotation of the roller shift motor 2 [H]. And then, based on the pre-detected data by the edge sensor [B], the machine corrects the main-scan direction of the paper position.

In case of paper that is more than 220mm feed-length (more than B5 SEF), in addition to the roller shift motor 2 [H], the roller shift motor 1 [I] also drives at the same time. So the duplex exit roller [G] and the duplex transport roller 2 / 3 / 4 [D] [E] [F] all shift at the same time in order to correct the position.

The amount of the registration can be adjusted with SP mode (See the Service Manual "Troubleshooting > Adjustment005:Registration").

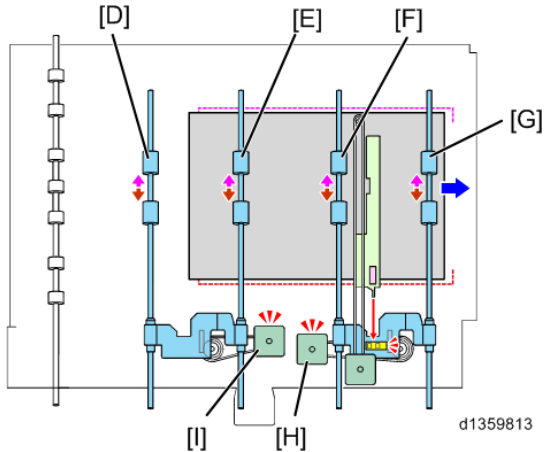

◆ **Side-to-side Registration Method Difference (Between each machine type)**

**113. MPC7501/MPC6501 (Jogger Fence Method)**

By the jogger fence, the registration correction is done and paper goes to the duplex path. Paper registration applies at switch-backing. So when paper passes in simplex (before image-transferring), paper position and the difference of spaces between the former passing paper and the latter passing paper are not adjusted. The transport path distance from the switch-backing area to the face / back image-transferring part is long

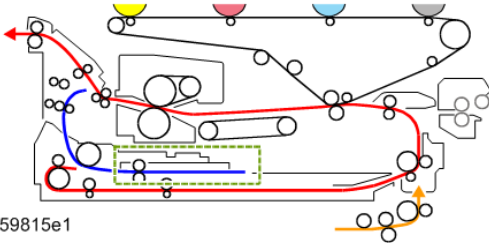

d1359815e1

\***Green:** Registration area (jogger fence area)

**114. MPC8002SP/MPC6502SP//ProC5100S/ProC5110S (Roller Shift Method)**

By detecting the edge of paper while paper passes through the duplex path, the registration correction is done. Paper position adjustment applies after switch-backing. So when paper passes in simplex (before image-transferring), paper position and the difference of spaces between the former passing paper and the latter passing paper are not adjusted. Compared to MPC7501/MPC6501, after paper adjustment, the transport path distance from the switch-backing area to the back image-transferring part is shorter, that means this type is superior to MPC7501/MPC6501 in paper transport stability.

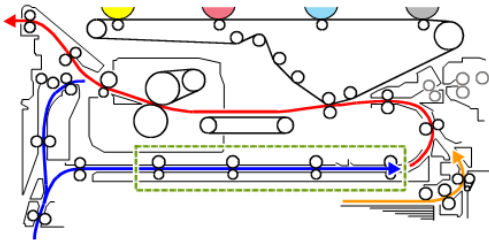

d1359815e2

\***Green:** Registration area (edge detection area)

\*About the roller shift method, see "Roller Shift" mentioned above.

**115. Proc751EX/Proc651EX (Roller Unit Shift Method)**

Regardless of feed / duplex, the registration correction is done when paper passes through the shift unit. Both sides of paper pass through the mechanical registration part. So this type has high stability for paper transport and high registration accuracy for both sides of paper.

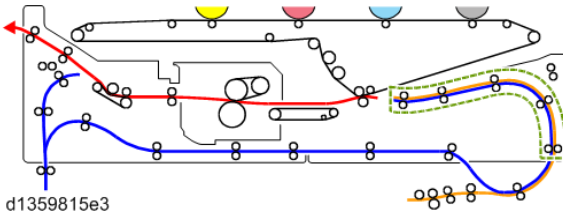

\*Green: Registration area (edge detection area)

**19.2.2 INVERT / EXIT****◆ Paper Cooling**

The paper cooling pipe roller [A] cools paper that is just output from the fusing unit.

The paper cooling pipe [A] has fins on the end of its shaft. The cooling fan [B] cools the pipe fins in order to cool the entire pipe.

On the rear side of the paper cooling pipe, the heat pipe set sensor switch [C] is installed that detects whether the paper cooling pipe unit is placed or not.

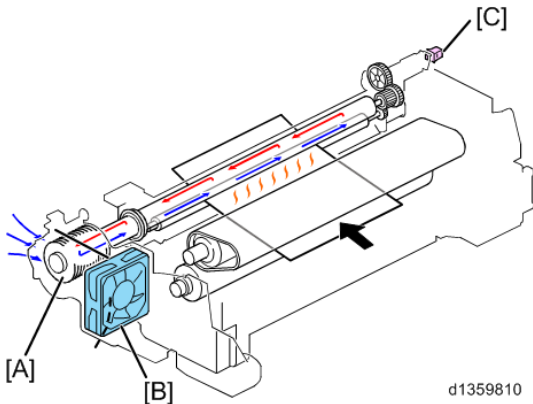
**◆ Straight Through Output (Face-up Output)**

When straight through output, transferred paper from the fusing unit passes through under the paper cooling pipe [A]. When the inverter entrance junction-gate motor [C] keeps driving the CCW direction in a certain time, the inverter entrance junction-gate [B] is pushed down and paper is sent to the exit roller [D] that transfers paper to the decurler unit.

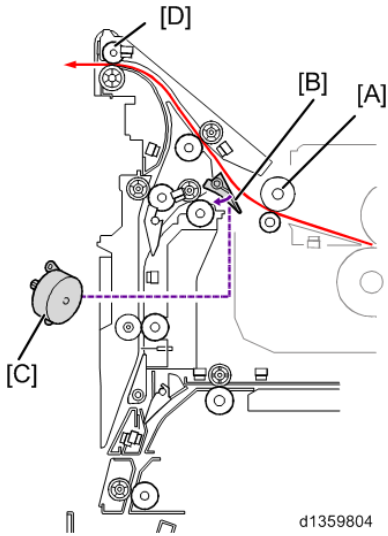

◆ **Invert Output (Face-down Output)**

In invert output (face-down output) operation, paper is transferred from the paper cooling pipe to the inverter exit path with the inverter entrance junction gate [B]. The inverter entrance junction gate motor drives to the CW direction in a certain time before it stops.

The rear edge of paper passes through the paper cooling pipe and the inverter entrance motor [B] gathers its speed at the same time. And then, with the inverter entrance motor [B] and the inverter exit motor [C], paper is output.

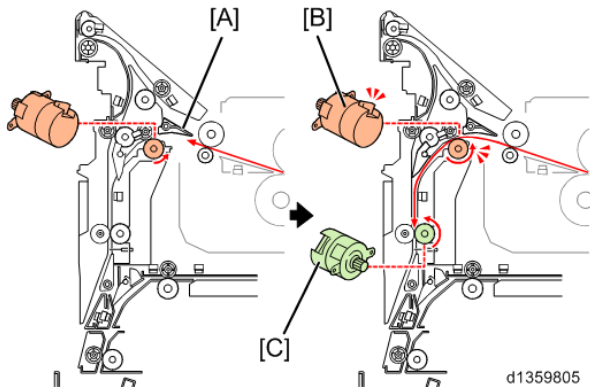

The inverter exit sensor [A] detects the rear edge of paper and the inverter entrance motor stops. Then the inverter exit motor rotates in reverse to transport paper to the exit part (invert transport).

In the exit part, the inverter exit motor [C] drives the exit roller [D] and the inverter exit roller [C] in order to output paper.

**Comment [オブライエン75]:** What is the name of sensor [A] – before you say inverter exit sensor, please see D in the next section (maybe this D should be duplex entrance sensor?) – names of sensors are not clear yet –

RE: 12/26  
 [A] is “inverter exit sensor”  
 [D] in the diagram in the next section is “duplex inverter sensor” (I corrected).

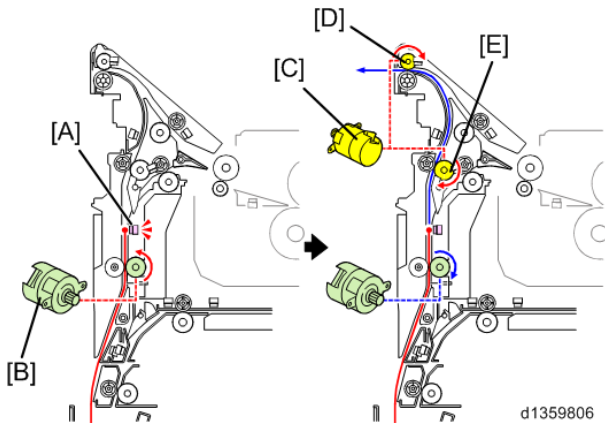

### 19.2.3 DUPLEX

#### ◆ Drive Components

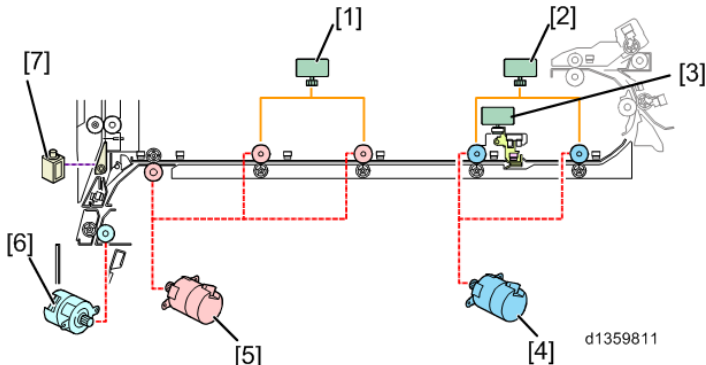

116.	Roller Shift Motor 1
117.	Roller Shift Motor 2
118.	Sensor Shift Motor
119.	Duplex Exit Motor
120.	Duplex Transport Motor
121.	Duplex Inverter Motor
122.	Duplex Inverter Solenoid

#### ◆ Duplex Transfer

After the duplex inverter sensor [D] detects the leading edge of paper, the duplex inverter solenoid [A] turns ON and paper goes to the duplex transfer part. The duplex inverter motor [C] drives to send the paper to the inverting area. Paper passes through duplex transport path via that of the inverter exit unit and the duplex unit.

Transferred paper, after the timer-time for duplex transfer control passes, is sent to the duplex path with the duplex transport motor [E] drives inversely (switch-back operation).

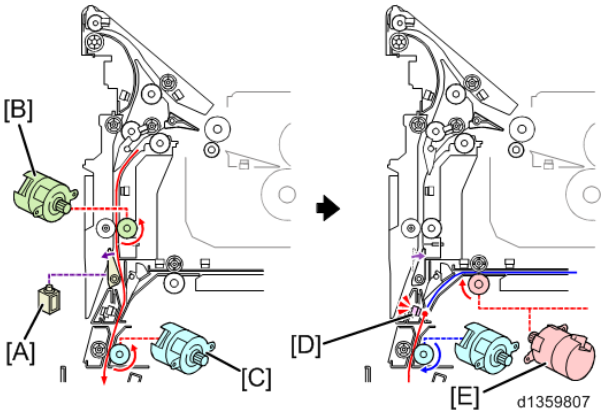

◆ **Duplex Interleaving**

The number of interleaving in duplex printing depends on the size of paper and there are two following patterns;

- More than 139.7 mm to 220 mm size: 3-sheet interleaving
- More than 221 mm to 487.7 mm size: 2-sheet interleaving

**Paper location and flow in 3-sheet interleaving pattern**

The image transfer order in 3-sheet interleaving pattern is as follows;

1st sheet face-up → 2nd sheet face up → 3rd sheet face up → 1st sheet face down → 4th sheet face up → 5th sheet face up → 3rd sheet face down → 6th sheet face up → 4th face down → 7th face up

\*Refer to the diagram below

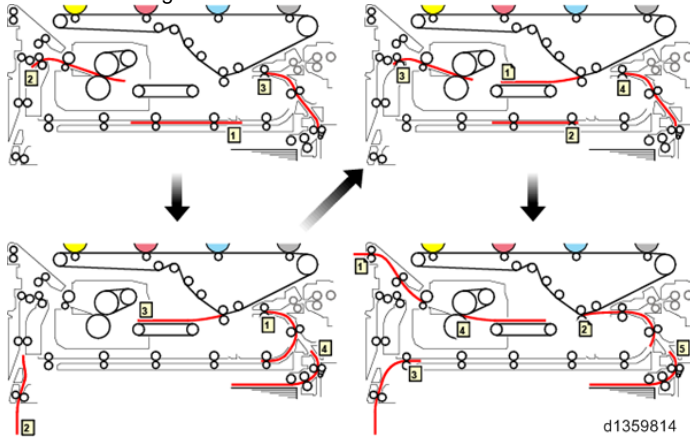

## 20. PAPER PURGE

### 20.1 MECHANISM DESCRIPTIONS

With the switch installed on the inverter exit duplexing part, the left-under of the machine, you can eject jam paper to a specified tray.

- With the left switch (red-arrowed), jam paper in the exit inverter path in the machine can be transported to the paper exit tray.
- With the right switch (blue-arrowed), jam paper in the duplexing inverter path in the machine can be transported to the purge tray.

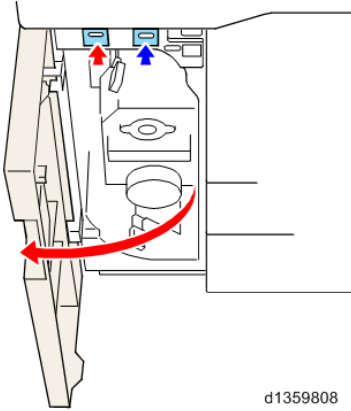

d1359808

## 20.1.1 MECHANISM DETAILS

### 123. Inverting (Purge)

When jam occurs, jammed paper that remains over the main machine to the drawer unit (Paper feed part) is sent to the purge part to clear up.

When the duplex inverter sensor [A] or the inverter relay sensor [B] detects paper, the right side of the main LED-SW is pushed to operate the following parts below (in order to send paper to the purge part):

- Paper Exit Motor ON (CCW)
- Inverter Entrance Motor ON (CW)
- Paper Exit Inverter Motor ON (CW)
- Fusing Motor ON (CW)
- \*Except the case of jam caused by fusing wrong
- Exit Inverter SOL ON
- Duplex Inverter Motor ON (CW)
- \*At the time of Duplex Inverter Sensor ON
- Duplex Transfer Motor (CW) [In the opposite direction to normal operation]
- \*At the time of the duplex entrance sensor ON

In the inverter part, the purged paper sensor [C] exists that detects whether paper is there or not.

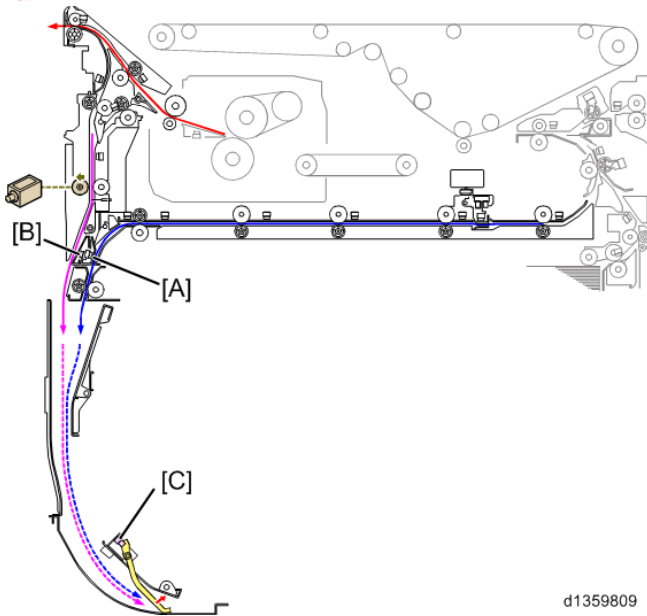

d1359809

## 21. ELECTRICAL COMPONENTS

### 21.1 BLOCK DIAGRAM

#### 21.1.1 BOARD LOCATION

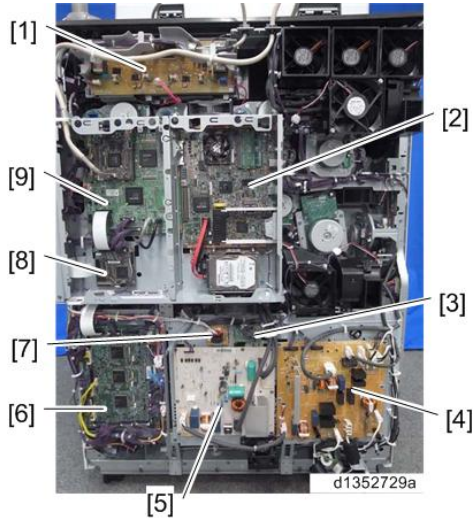

- 124. HVPS C/B
- 125. Controller Board
- 126. FDB-M (Pro only)
- 127. AC Drive
- 128. IH Inverter
- 129. PFB
- 130. ACRY (Pro only)
- 131. BCU
- 132. IPU

Block Diagram



[1]

[3]

[2]

d1352730a

- 133. Potential Sensor Board (Back of the fan)
- 134. PSU 2 (Back of the IH Inverter)
- 135. PSU 1 (Back of the IH Inverter)



[1]

d1352731a

- 136. IOB

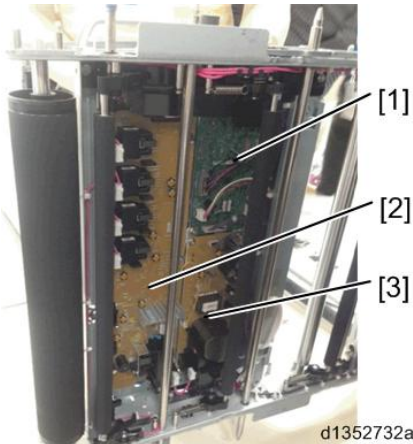

d1352732a

- 137. TDRB
- 138. ITB / PTR Power Pack
- 139. AC Power Pack (Pro only)



d1352733a

- 140. HVPP : D
- 141. DUB
- 142. FDB-D (Pro only)

Block Diagram



143. TSB

[1]

d1352734a

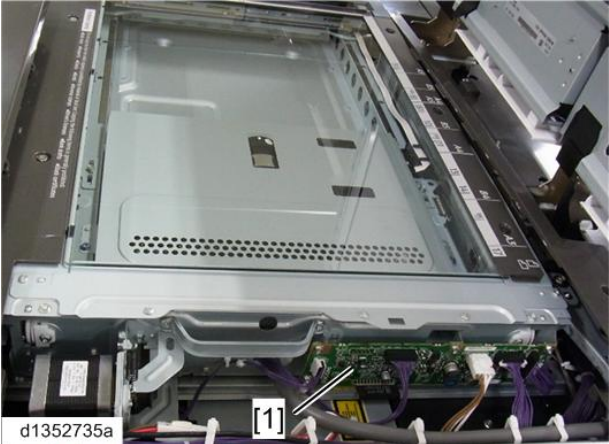

144. SIOB

[1]

d1352735a

## 21.2 MECHANISM DESCRIPTIONS

### 21.2.1 EACH BOARD OUTLINE

- IOB (IN/Out Control Board)  
Controls loads of solenoids, motors and sensors in an engine part
- PFB (Paper Feed Board)  
Controls loads of solenoids, motors and sensors in a paper transfer part
- DUB (Drawer Unit Board)  
Controls loads of solenoids, motors and sensors in a drawer unit part
- TSB(Toner Supply Board )  
Controls loads of motors and sensors in the toner supply unit part
- BCU(Base-engine & Control Unit)  
Controls the engine
- IPU(Image Processing Unit)  
Controls an image process
- Controller Board  
Controls whole machine systems such as;  
Printer / Scanner Control  
Memory Control (including HDD)  
Operation Panel Control  
**This board has a Dip switch (default: on) But this should not be changed or used normally.**
- TDCU (Transfer Drive Control Unit)  
Controls an image transfer drive unit
- ACRY (Pro C5100S/Pro5110S only)  
Controls interlock for TCRU
- FDM-M (Pro C5100S/Pro5110S only)  
Controls the belt refresh motor contact / separation in the fusing unit
- FDM-D(Pro C5100S/Pro5110S only)  
Controls WEB contacted / separated
- SIOB (Scanner I/O Board)  
A drive control board for sensor I/F and the stepping motor for carriage drive in a scan unit
- SBU (Sensor Board Unit)  
Converts a CCD scan image into analog signals and also converts analog signals into digital signals.  
SBU has SIOB I/F and controls scanner inner I/O signals according to the order from the CPU.
- ITB / PTB power pack
- TDRB (Transfer Driver Board)  
Controls the ITB unit
- LDB (Laser Diode Drive Board)  
LD control board that works for the VCSEL drive

**Comment [n 76]:** 3/11 added

**Comment [オブライエン77]:** Sorry, don't understand

RE:

This means "ACRY is the board that is for TCRU interlock control." But I cannot find specified things with the Japanese original.

## Mechanism Descriptions

- OPU  
Controls the operation panel
- SUB
- MAIN
- APPLI
  
- AC Drive  
Performs AC control for the fusing heater and the anti-condensation heater
  
- PSU(Power Supply Unit)  
Supplies DC power source with each board
  
- IH Inverter  
Controls the heat roller in the fusing part

When DC power source turns OFF, the existing machines doesn't pass power source to the area beyond the inlet on the AC controller board. But in this machine, turning DC power source OFF cannot cut power source of the whole machine (5V is still energized state). So put the plug out when parts replacement.

### 21.2.2 FUSE LIST

#### ◆ AC Type

AC Controller Board (D0165460) [100V]

Fuse Name	Current Rating	Part No.	Output Connector	Destination	Remarks
FU101	15A	11071252	CN400	Pressure Heater	Fuse Tube (Removable)
			CN401	<ul style="list-style-type: none"> <li>▪ Bank Anti-Condensation Heater (Upper)</li> <li>▪ Bank Anti-Condensation Heater (Lower)</li> </ul>	
			CN402	<ul style="list-style-type: none"> <li>▪ PCU Anti-Condensation Heater</li> <li>▪ Scanner Anti-Condensation Heater</li> </ul>	
			CN405	Anti-Condensation Heater SW	
			CN411	PSU1 PSU2	
FU102	20A	11071350	CN407	IH Inverter	Fuse Tube (No-removable)
FU103	2A	11071225	CN401	<ul style="list-style-type: none"> <li>▪ Bank Anti-Condensation Heater (Upper)</li> <li>▪ Bank Anti-Condensation</li> </ul>	Micro Fuse (No-removable)

			CN402	Heater (Lower) <ul style="list-style-type: none"> <li>▪ PCU Anti-Condense Heater</li> <li>▪ Scanner Anti-Condensation Heater</li> </ul>	
FU105	10A	11071347	CN411	PSU1	Fuse Tube (Removable)
FU106	10A	11071347	CN411	PSU2	

AC Controller Board (D0165460) [200V]

Fuse Name	Current Rating	Part No.	Output Connector	Destination	Remarks
FU101	10A	11071347	CN400	Pressure Heater	Fuse Tube (Removable)
			CN401	<ul style="list-style-type: none"> <li>▪ Bank Anti-Condensation Heater (Upper)</li> <li>▪ Bank Anti-Condensation Heater (Lower)</li> </ul>	
			CN402	<ul style="list-style-type: none"> <li>▪ PCU Anti-Condense Heater</li> <li>▪ Scanner Anti-Condensation Heater</li> </ul>	
			CN405	Anti-Condensation Heater SW	
			CN411	PSU1 PSU2	
FU102	10A	11071347	CN407	IH Inverter	Fuse Tube (No-removable)
FU103	2A	11071225	CN401	<ul style="list-style-type: none"> <li>▪ Bank Anti-Condensation Heater (Upper)</li> <li>▪ Bank Anti-Condensation Heater (Lower)</li> </ul>	Micro Fuse (No-removable)
			CN402	<ul style="list-style-type: none"> <li>▪ PCU Anti-Condense Heater</li> <li>▪ Scanner Anti-Condensation Heater</li> </ul>	
FU105	5A	11071344	CN411	PSU1	Fuse Tube (Removable)
FU106	5A	11071344	CN411	PSU2	

- Fuses Location on AC Controller Board

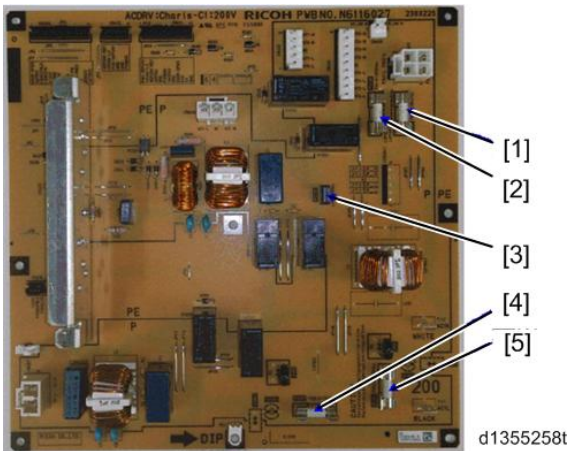

- 145. FU105
- 146. FU106
- 147. FU103
- 148. FU102
- 149. FU101

◆ DC Type

PSU1 (AZ240226) [100V / 200V]

Fuse Name	Current Rating	Output Connector	Destination	Remarks
FU1	5A	CN443 -4,5,6	None	Micro Fuse (No-removable)
FU2	5A	CN443 -1,2,3	None	Micro Fuse (No-removable)

PSU2 (AX240230) [100V / 200V]

Fuse Name	Current Rating	Output Connector	Destination	Remarks
FU1	5A	CN443 -4,5,6	IPU IOB Decurlar Unit	Micro Fuse (No-removable)
FU2	5A	CN443 -1,2,3	DUB TDRB TSB	Micro Fuse (No-removable)
FU3	10A	CN446 -5,6,7,8	ADF	Fuse Tube (Removable)
		CN447 -4,5,6,7	Upstream Peripherals	
FU4	10A	CN448 -5,6,7,8	Downstream Peripherals	Fuse Tube (Removable)
FU5	10A	CN444 -1,2,3,4	SIO Decurlar Unit	Fuse Tube (Removable)

- Fuses Location on PSU

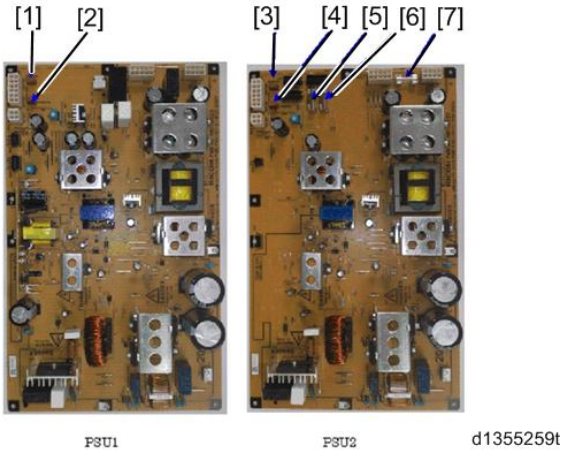

- 150. FU1
- 151. FU2
- 152. FU1
- 153. FU2
- 154. FU3
- 155. FU4
- 156. FU5

Charis-C1 IPU Fuse Specifications (MPC6502SP / MPC8002SP / Pro C5100S / Pro C5110S common)  
 (PCB No.: D1365724A)  
 Fuse List

Fuse Name	Output Connector	Fuse Capacity	Voltage	Destination
FU2	CN582-12 ~ 15	5.0A	5.1V (VCCX)	OPU
FU3	CN579-16, 19	1.6A	5.1V (VCCX)	AKS / DOCSET Sensor
FU5	CN598-1	0.75A	24V (VCC)	Patlite (signal light)
FU6	CN583-1	2.0A	5.1V (VCCX)	OPU(USB)

▪ Fuses Location on IPU board

Comment [ n 78]: イラスト依頼中

## Mechanism Descriptions

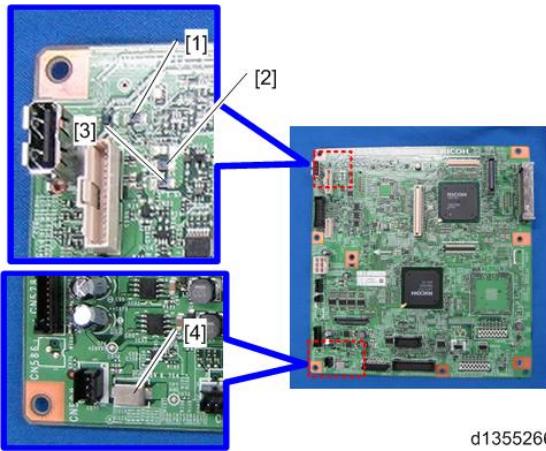

d1355266t

- 157. FU6
- 158. FU2
- 159. FU3
- 160. FU5

### a) CTL Fuse List

Fuse Name	Output Connector	Fuse Capacity	Voltage	Destination
FU1	-	5.0A	5.1V (5VX)	CTL inner guard
FU2	USB-Host CN	5.0A	5.1V (5VX)	USB Bluetooth IC Card etc.
FU3	SD Card Slot CPU FAN Power Source CN CASE FAN Power Source CN RiO3 Option CN PCIe Option CN LAN CN USB Device CN etc.	5.0A	5.1V (5VX)	SD Card CPU FAN CASE FAN RiO3 Option PCIe Option LAN USB Device etc.
FU4	RiO3 Option CN etc.	5.0A	5.1V (5VX)	RiO3 Option CN etc.

#### ▪ Fuses Location

Comment [n 79]: イラスト依頼中

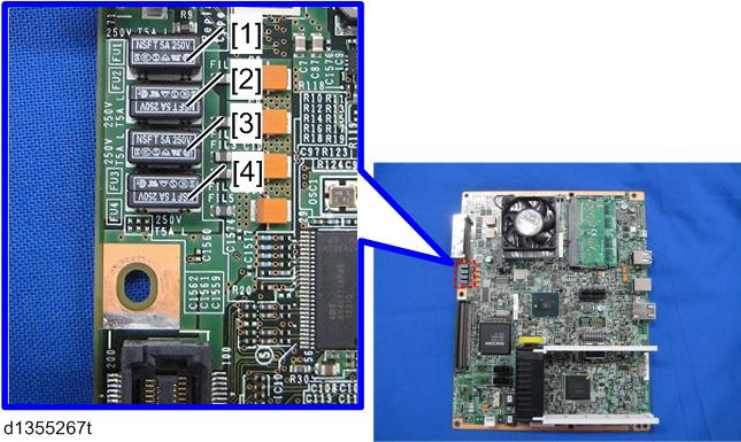

d1355267t

- 161. FU1
- 162. FU2
- 163. FU3
- 164. FU4

### 21.2.3 HDD DETAILS (MEMORY CAPACITY FOR STORED DOC.)

MPC6502SP / MPC8002SP: 250GBx2 are available for image-storing

Pro C5100S / Pro C5110S: 250GBx2 are available for image-storing

	MPC6502SP / MPC8002SP / Pro C5100S / Pro C5110S common
Memory Capacity	320GBx2
Memory Capacity for Document Box	170.9GB
Store Capacity	<b>Storing only with the copy function:</b> BW Original: Approx. 15,000 pages Full-color Original: Approx. 5,000 pages *Condition 600dpi/ A4 / BW / 8bit / NFC1 compression
	<b>Storing only with the printer function:</b> BW Original: Approx. 15,000 pages Full-color Original: Approx. 15,000 pages *Condition 600dpi/ A4 / BW / 2bit / HAIC-P2
	<b>Storing only with the scanner function:</b> Approx. 15,000 pages *Condition 200dpi/ A4 / Full-color / 8bit / JPEG
Document Box Capacity	Max. 3,000 docs
Total Page Capacity in All Functions	Total 15,000 Pages
Page Capacity per doc.	Max. 3,000 Pages /doc.
Memory Sort Capacity	Approx. 40GB
	<Details>
	For copy: 25GB
	For printer: 8GB
	For printer interruption: 8GB

## 22. USED TONER COLLECTION

### 22.1 MECHANISM DESCRIPTIONS

#### 22.1.1 GENERAL

Toner, developer and paper dust which are dumped from the each unit are collected in the toner bottle as used toner automatically.

The used toner path is composed of used toner upper transfer, vertical transfer, and under transfer.

#### 22.1.2 LAYOUT

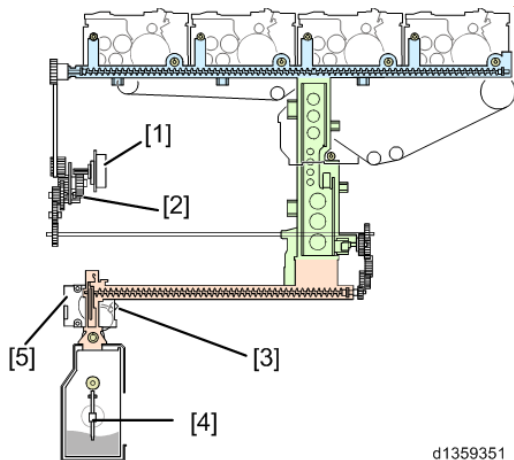

- 165. Used Toner Collection Motor
- 166. Used Toner Transport Lock Sensor
- 167. Used Toner Bottle Lock Sensor
- 168. Used Toner Bottle Near-full Sensor
- 169. Used Toner Bottle

Comment [n 80]: 12/21/12  
added

#### 22.1.3 COMPONENTS

Flow Diagram

## 22.2 MECHANISM DETAILS

### 22.2.1 USED TONER TRANSFER

#### ◆ Used Toner Transfer

There are three paths as a used toner transfer.

##### a) Used Toner Upper Transfer

Used toner from the drum cleaning [B]

Used developer from the development unit [A]

##### b) Used Vertical Transfer

Used toner and paper dust from the ITB cleaning [C]

##### c) Used Toner under Transfer

Transfers used toner, developer and paper dust which are collected from the each part to the used toner collection bottle [D].

The operation panel shows "SC488" (used toner motor lock) in which the used toner motor lock sensor acts and the used toner collection motor is stopped because the transfer screw is clogged and cannot rotate in transferring used toner.

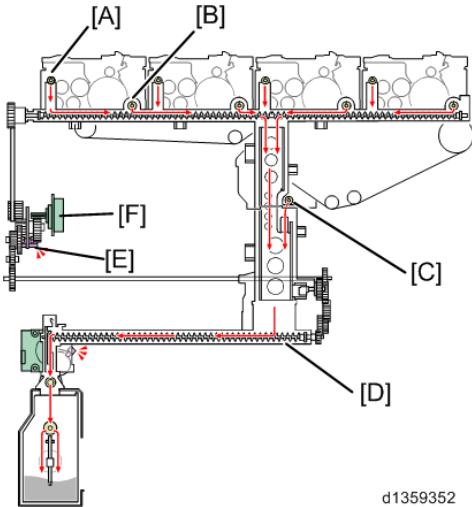

Comment [n 81]: 12/21/12  
Added.

## 22.2.2 USED TONER BOTTLE TRANSFER / USED TONER BOTTLE DRIVE / TORQUE SENSOR PART

Used toner that is sent from the used toner under transfer falls into the used toner bottle [C] via the toner collection transfer screw and the collection bottle transfer screw [A].

The operation panel shows "SC486" (Used toner bottle motor abnormal) where rotate torque of the screw [A] in the toner collection part and the collection bottle transport screw [B] rises while rotating speed downs. And then the used toner motor lock sensor [D] acts and the used toner bottle collection motor [E] is stopped.

The used toner bottle motor lock is detected when some burden applies to the toner collection bottle screw and feeler cannot rotate.

- Used Toner Bottle Drive**  
 The used toner bottle collection motor [E] drives the collection part transport screw [A] and the collection bottle transport screw [B] through the gears.
- Torque Detection Part**  
 When any of the parts; the used toner collection screw [B], the lower inner transport screw [F] (used toner transport pipe) gains the torque, the torque limiter slips and the photo interrupter [D] detects the slip state.

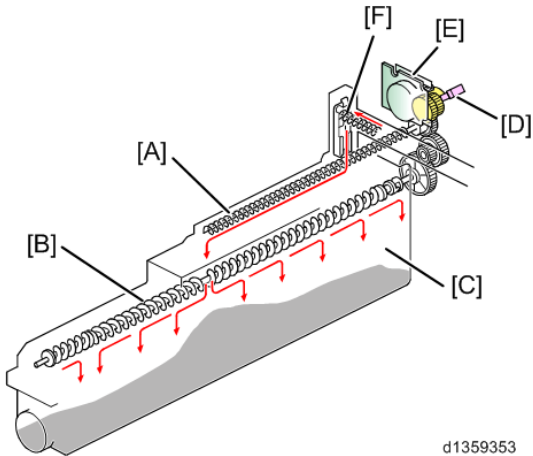

d1359353

### 22.2.3 EACH SENSOR DETECTION

The used toner bottle set sensor switch [A] judges whether the used toner bottle [B] is set properly or not.

To detect the amount of toner in the used toner bottle, the used toner bottle near-end full sensor [C] is installed. The used toner bottle near-end full sensor judges used toner bottle near-full when the feeler [E] interrupts the used toner bottle near-end full sensor.

The full detection is occurred on a certain amount of sheets is copied (MP C6502SP/MP C8002SP: about 30k, Pro C5100S/C5110S: about 12k) after the used toner bottle near full detection.

Used toner falls in the bottle from front to rear, then rear to front in order not to accumulate used toner disproportionately.

In a bottle placement, the magnet catch [D] attracts the plate that is attached on the used toner collection bottle [B] in order to seat the used toner bottle correctly. At this time, the used toner collection bottle pushes the used toner collection bottle set sensor switch [A] that detects whether the used toner collection bottle is placed or not.

Besides, the feeler [E] that is attached on the used toner collection bottle interrupts the used toner bottle near-full sensor

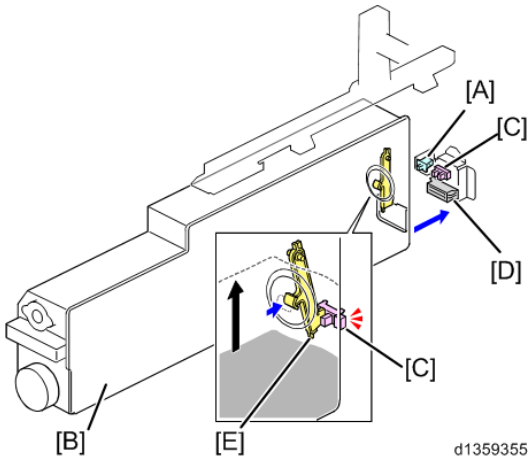

**Comment [ n 82]:** 12/21/12  
Added.

---

## 23. BUFFER PASS UNIT TYPE 5020

### 23.1 OVERVIEW

#### 23.1.1 GENERAL SPECIFICATIONS

Item	Descriptions	Remarks
Supported Thickness	52~300g/m2	
Supported Paper Size	Postcard (SEF), A6 (SEF), HLT, 100×139.7mm ~ 330×630mm	
Power Source	100V, 50/60Hz, 3A	
Max Energy Consumption	200W or less	
Dimensions (W x D x H)	330×730×1000mm	
Weight	Approx. 90 kg	

### 23.1.2 OVERVIEW LAYOUT

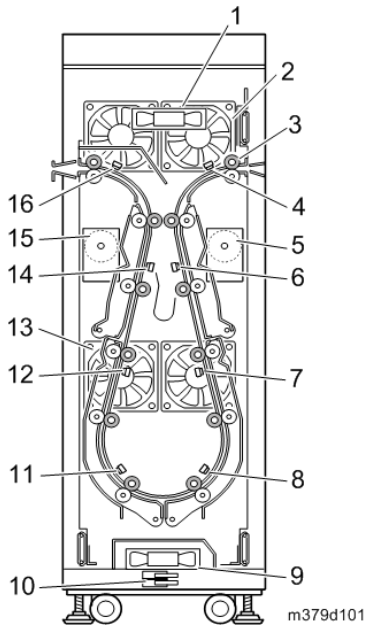

- 170. Upper Cooling Fan
- 171. Upper Exhaust Fan
- 172. Transport Roller
- 173. Transport Sensor1
- 174. Right Transport Motor
- 175. Transport Sensor2
- 176. Transport Sensor3
- 177. Transport Sensor4
- 178. Lower Cooling Fan
- 179. Front Door Open/close Switch
- 180. Transport Sensor5
- 181. Transport Sensor6
- 182. Lower Exhaust Fan
- 183. Transport Sensor7
- 184. Left Transport Motor
- 185. Transport Sensor8

### 23.1.3 DRIVE LAYOUT

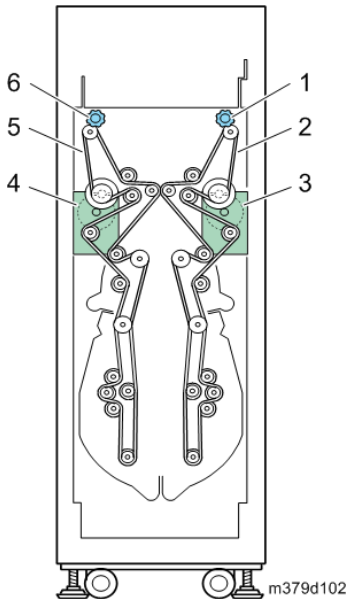

- 186. Right Transport Knob
- 187. Right Timing Belt
- 188. Right Transport Motor
- 189. Left Transport Motor
- 190. Left Timing Belt
- 191. Left Transport Knob

## 23.2 DETAILS

### 23.2.1 PAPER PATH

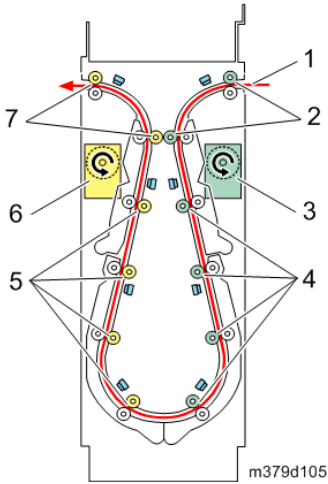

- 192. Transport Path
- 193. Transport rollers driven by the right transport roller.
- 194. Right Transport Roller
- 195. Transport rollers driven by the right transport roller.
- 196. Transport rollers driven by the left transport roller.
- 197. Left Transport Roller
- 198. Transport rollers driven by the left transport roller.

Paper that comes from the main machine passes to the entrance of the buffer pass unit. The drive motor (right) starts 1.05 seconds after the start of a copy or print job, and six transport rollers on the right side of the path rotate to transport paper to the left side. The drive motor (left) starts to rotate 1.05 seconds after the drive motor (right) starts and this rotates six transport rollers on the left side to send paper to the exit. The buffer pass unit has eight sensors that detect jams; operation stops when a jam is detected.

### 23.2.2 PAPER COOLING

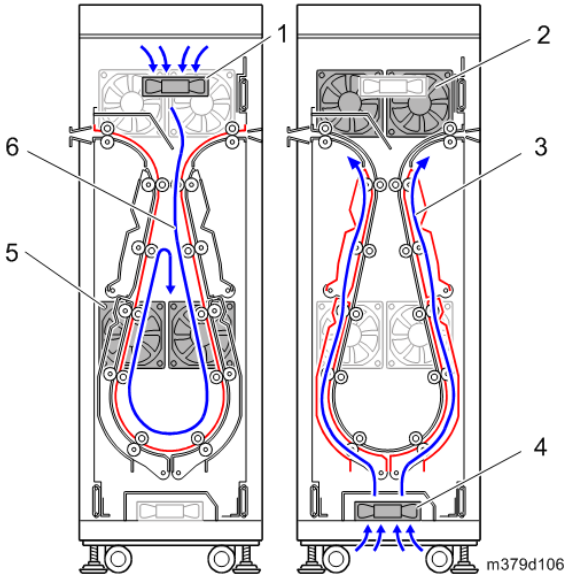

- 199. Upper Cooling Fan
- 200. Upper Exhaust Fan
- 201. Air Current
- 202. Lower Cooling Fan
- 203. Lower Exhaust Fan
- 204. Air Current

The buffer pass unit includes two sets of two exhaust fans and two sets of two cooling fans. After copy job or a printer job has been received, these fans start at 0.1 second intervals in the following order:

**Upper Exhaust Fans > Lower Exhaust Fans > Upper Cooling Fans > Lower Cooling Fans**

Air pulled in by the upper cooling fans passes through the inner side of the paper path, and goes out of the machine through the lower exhaust fan. Air pulled in by the lower cooling fan passes along the outer side of the paper path, and goes out of the machine through the upper exhaust fan. These air flows cool down both faces of the paper, then the paper goes to the exit. You can adjust the length of time that the fans operate after the end of a job with SP1932-001. (0 min. to 60 min. / default: 1 min.)

## 24. COVER INTERPOSER TRAY CI4010

### 24.1 OVERVIEW

#### 24.1.1 GENERAL SPECIFICATIONS

Item	Descriptions	Remarks
Name	Cover Interposer Tray CI4010	
System	Cover Interposer for Finisher	
Separation Method	FRR Separation	
Transfer Method	Roller	
Passable Paper Size	A3 SEF ~ A5, DLT SEF ~ HLT	Feed straight through: 13" x 19"
Thickness (Paper Weight)	64 ~ 216g/m2	Feed straight through: 300g/m2
Paper Type	White Paper, Print Paper, Ricoh PPC, Image-transferable Print Paper	
Allowable Curl Amount	H: 5mm or less, more than 30R	
Tray Capacity	200 Sheets (80g/m2)	
Paper End Detection	Available	
Supported Supplied DC	DC24V±10%、DC5V±5%	
Power Consumption	43W or less	
Dimensions	(W) 500 x (D) 600 x (H) 600	
Weight	12kg or less	

#### 24.1.2 SUPPORTED PAPER

Paper Quality, Paper Type	Designated Paper		Plain Paper								Woody Paper	Recycled Paper
	T6000, 6200	HQ paper 20 lb	HQ paper 80g/m2	HQ paper 157.0g/m2	HQ paper 127.9g/m2	HQ paper 104.4g/m2	HQ paper 81.4g/m2	HQ paper 64.0g/m2	HQ paper 52.3g/m2			
A3 Short Edge (SE)	•	-	•	•	•	•	•	•	•	x	-	-
B4 SE	•	-	•	•	•	•	•	•	•	x	-	•
A4 SE	•	-	•	•	•	•	•	•	•	x	x	•
A4 Long Edge (LE)	•	-	•	•	•	•	•	•	•	x	x	•
B5 SE	•	-	•	•	•	•	•	•	•	x	x	•
B5 LE	•	-	•	•	•	•	•	•	•	x	x	•
A5 SE	•	-	•	•	•	•	•	•	•	x	-	-
A5 SE LE	•	-	•	•	•	•	•	•	•	x	-	-
B6 SE	x	-	x	x	x	x	x	x	x	x	-	-
B6 LE	x	-	x	x	x	x	x	x	x	x	-	-
8 1/2"x14"SE	•	•	•	•	•	•	•	•	•	x	-	•

	Designated Paper			Plain Paper								
8 1/2"x1 1" SE	●	●	●	●	●	●	●	●	●	x	-	●
8 1/2"x1 1"LE	●	●	●	●	●	●	●	●	●	x	-	●
5 1/2"x8 1/2" SE	●	●	●	●	●	●	●	●	●	x	-	●
5 1/2"x8 1/2" LE	●	●	●	●	●	●	●	●	●	x	-	●

●: Passable  
x: Impassable  
-: Not Supported

Paper Quality, Paper Type	Application							
	Colored Paper	2nd Drawing Issue	Released paper SA	Letter, Ricoh Post Card	Off Master	OHP	Payment Slip	Business Card
A3 Short Edge (SE)	●	x	-	-	-	-	-	-
B4 SE	●	x	-	-	x	-	-	-
A4 SE	●	x	x	-	x	-	-	-
A4 Long Edge (LE)	●	x	x	-	x	x	-	-
B5 SE	●	x	-	-	x	x	-	-
B5 LE	●	x	-	-	x	x	-	-
A5 SE	-	-	-	-	-	-	x	-
A5 SE LE	-	-	-	-	-	-	x	-
B6 SE	-	-	-	-	-	-	-	-
B6 LE	-	-	-	-	-	-	-	-
8 1/2"x14"SE	●	-	-	-	-	-	-	-
8 1/2"x11" SE	●	-	-	-	-	-	-	-
8 1/2"x11"LE	●	-	-	-	-	-	-	-
5 1/2"x8 1/2" SE	●	-	-	-	-	-	-	-
5 1/2"x8 1/2" LE	●	-	-	-	-	-	-	-

●: Passable  
x: Impassable  
-: Not Supported  
SE: Short Edge Feed  
LE: Long Edge Feed

### 24.1.3 MAIN COMPONENTS

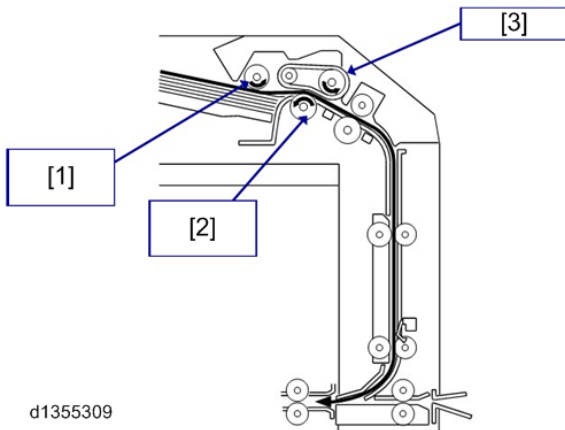

- d1355309
- 205. Pick-up Roller
  - 206. Reverse Roller
  - 207. Feed Belt

### 24.1.4 ELECTRICAL COMPONENT LAYOUT

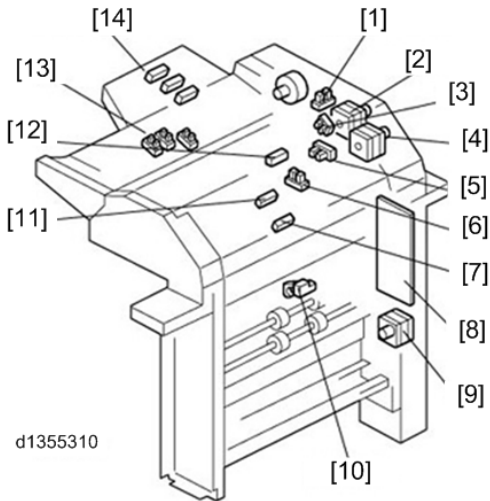

- d1355310
- 208. Feed Cover Set Sensor
  - 209. Feed Motor
  - 210. Bottom Plate Sensor
  - 211. Transport Roller
  - 212. Near End Sensor
  - 213. Bottom Plate HP Sensor
  - 214. Pick-up Sensor
  - 215. Controller Board
  - 216. Exit Motor
  - 217. Exit Sensor

- 218. Feed Sensor
- 219. Feed Set Sensor
- 220. Width Sensors 1 ~ 3
- 221. Length Sensor 1 ~3

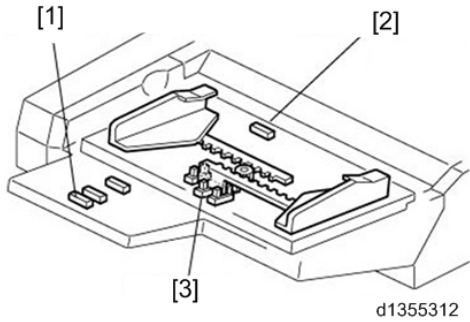

d1355312

- 222. Length Sensor 1 ~ 3
- 223. Feed Set Sensor
- 224. Width Sensor 1 ~ 3

### 24.1.5 DRIVE LAYOUT

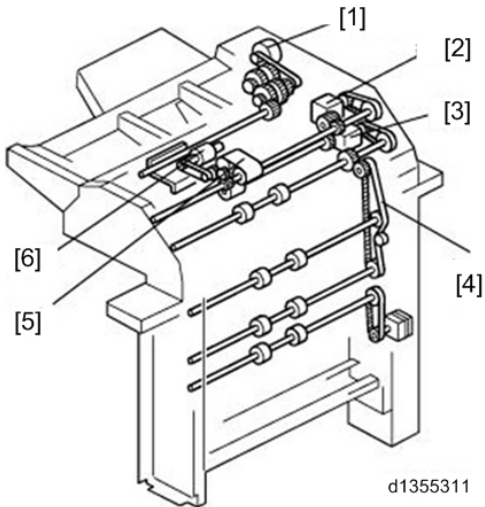

d1355311

- 225. Bottom Plate Motor
- 226. Feed Motor
- 227. Transport Motor
- 228. Timing Belt
- 229. Feed Belt
- 230. Pick-up Roller

## 24.2 DETAILS

### 24.2.1 PAPER FEED

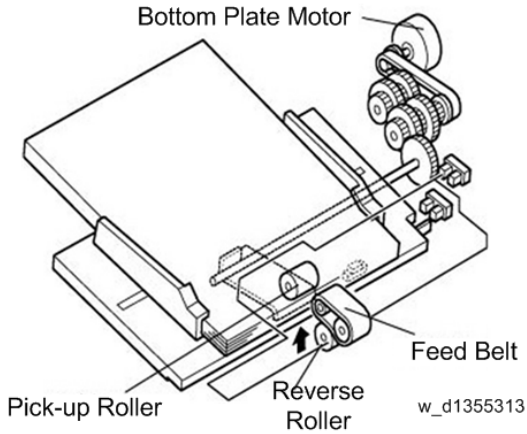

This machine has a feed belt and a reverse roller (FRR method).

The direction that the reverse roller turns depends on the frictional forces acting on it. When there is a single sheet of paper between the feed belt and reverse roller, the friction between the feed belt and the paper is greater than the reverse force from the reverse roller. So, the reverse roller turns in the direction of paper feed.

If two or more sheets are fed between the belt and roller, the forward force on the second sheet becomes less than reverse force from the reverse roller because of the low friction between the two sheets. So, the reverse roller drives the second sheet back to the tray.

Finally, the feed belt and the reverse roller feed the paper into the machine.

## 25. COVER INTERPOSER TRAY CI4020

### 25.1 OVERVIEW

#### 25.1.1 GENERAL SPECIFICATIONS

Item	Descriptions
Name	Cover Interposer Tray CI4020
System	Cover Interposer
Separation Method	Belt Friction Separation
Transfer Method	Roller
Passable Paper Size	Width: A5 SEF / HLT SEF ~ 13 inch (330mm) Length : A5 LEF / HLT LEF ~ 19.2 inch (487.7mm)
Thickness (Paper Weight)	64g/m <sup>2</sup> ~ 216g/m <sup>2</sup>
Paper Type	Ricoh PPC, Image-Transferable print paper
Allowable Curl Amount	H: 5mm or less, more than 30R
Tray Capacity	200 sheets (80g/m <sup>2</sup> ) × 2 drawers
Paper End Detection	Available
Supported Supplied DC	DC24V±10%
Power Consumption	84W or less
Dimensions	(W)540 mm × (D)730 mm × (H)1,270 mm
Weight	45kg or less

#### 25.1.2 ELECTRICAL COMPONENTS

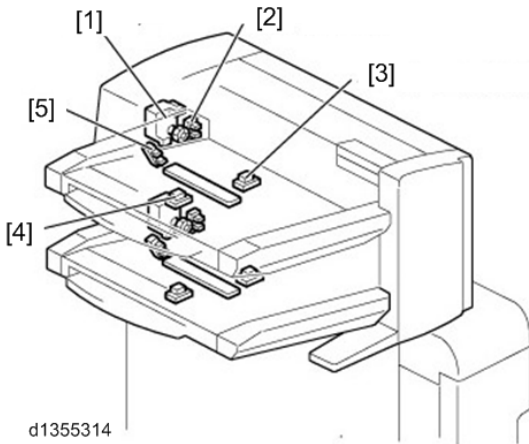

- 231. Lift Motor
- 232. Tray Lower Limit Sensor
- 233. Paper End Sensor
- 234. Length Sensor
- 235. Near End Sensor

## Overview

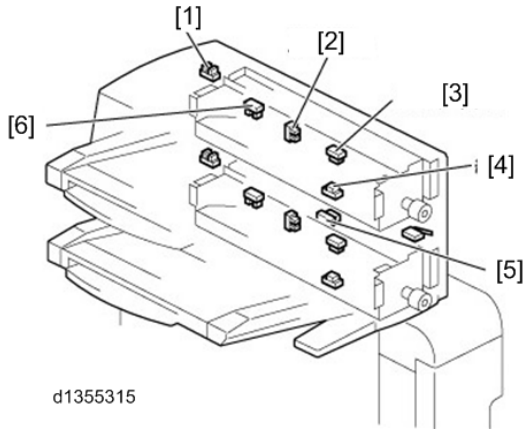

d1355315

- 236. Cover Open Sensor
- 237. Upper Limit Sensor
- 238. Pick-up Sensor
- 239. Feed Sensor
- 240. 1st Transport Sensor
- 241. Pick-up Arm HP Sensor

## 25.1.3 DRIVE LAYOUT

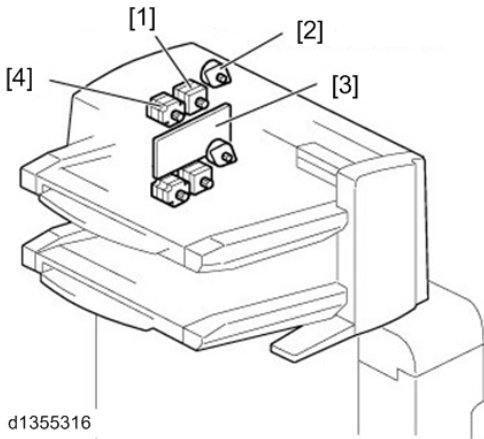

d1355316

- 242. Pull out Motor
- 243. Pick-up Motor
- 244. PCB
- 245. Feed Motor

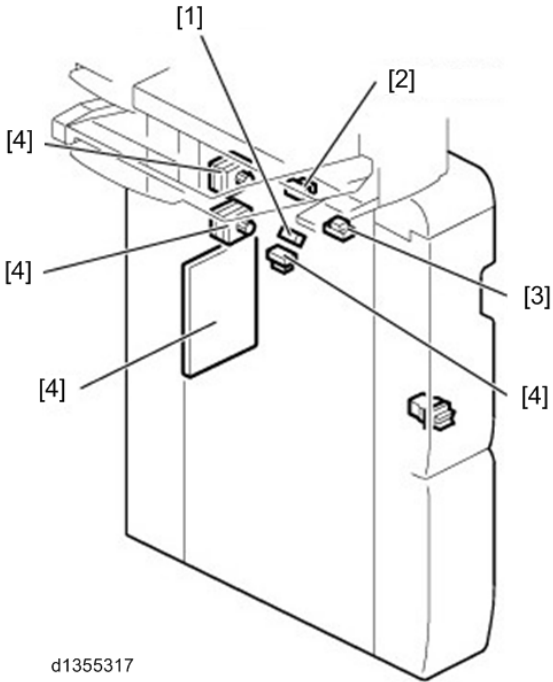

d1355317

- 246. Exit Sensor
- 247. 2nd Transport Sensor
- 248. Entrance Sensor
- 249. Exit Sensor
- 250. PCB
- 251. Horizontal Transport Sensor
- 252. Vertical Sensor

## 25.2 DETAILS

This machine has a feed belt and a reverse roller (FRR method).

The direction that the reverse roller turns depends on the frictional forces acting on it. When there is a single sheet of paper between the feed belt and reverse roller, the friction between the feed belt and the paper is greater than the reverse force from the reverse roller. So, the reverse roller turns in the direction of paper feed.

If two or more sheets are fed between the belt and roller, the forward force on the second sheet becomes less than reverse force from the reverse roller because of the low friction between the two sheets. So, the reverse roller drives the second sheet back to the tray.

Finally, the feed belt and the reverse roller feed the paper into the machine.

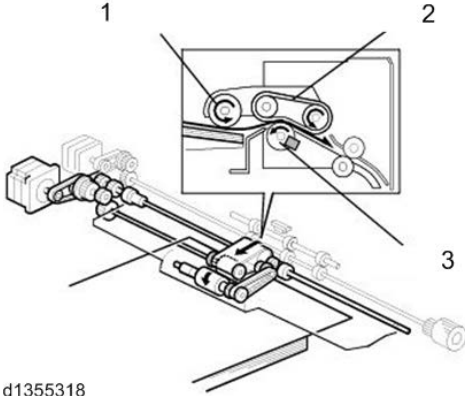

d1355318

- 253. Pick-up Roller
- 254. Feed Belt
- 255. Reverse Roller

## 26. 9-BIN MAILBOX CS4010

### 26.1 OVERVIEW

#### 26.1.1 GENERAL SPECIFICATIONS

Item	Descriptions	Remarks
Number of Bins	9	-
Stack capacity of each bin	100 Sheets (80g / m <sup>2</sup> )	For paper heavier than 80g / m <sup>2</sup> or more than 0.12mm thick, the limit on the paper stack depends on the paper weight.
Paper Size	A3 ~ A5 DLT ~ HLT	
Paper Weight	60 ~ 128g/m <sup>2</sup>	52 ~ 110kg
Power Consumption	Approximately 30W or less	
Power Source	DC24V, 5V	Supplied from the finisher
Dimensions	540mm(W) x 600mm(D) x 660mm(H) or less	Excluding the docking unit
Weight	15kg or less	

### 26.1.2 OVERVIEW LAYOUT

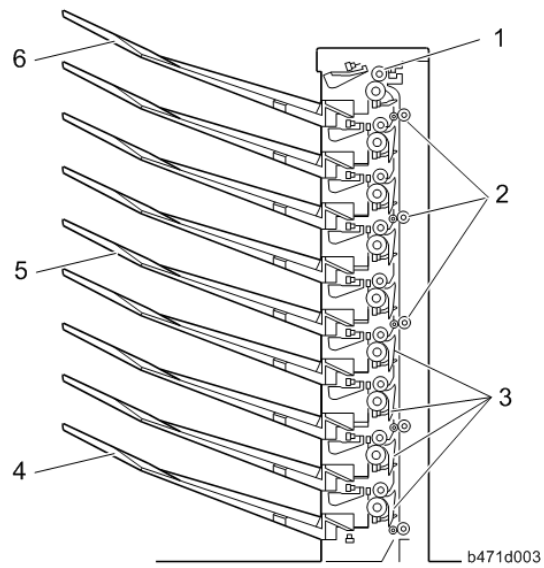

- 256. Exit Roller
- 257. Transport Roller
- 258. Junction Gate
- 259. 1 Bin Tray
- 260. 5 Bin Tray
- 261. 9 Bin Tray

### 26.1.3 DRIVE LAYOUT

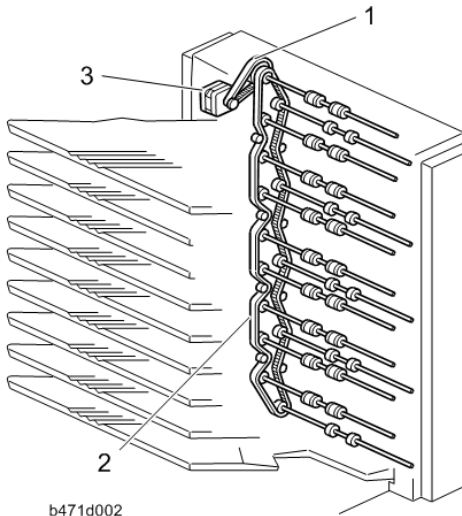

b471d002

- 262. Drive Timing Belt
- 263. Driven Timing Belt
- 264. Transport Motor

## 26.1.4 ELECTRICAL COMPONENTS

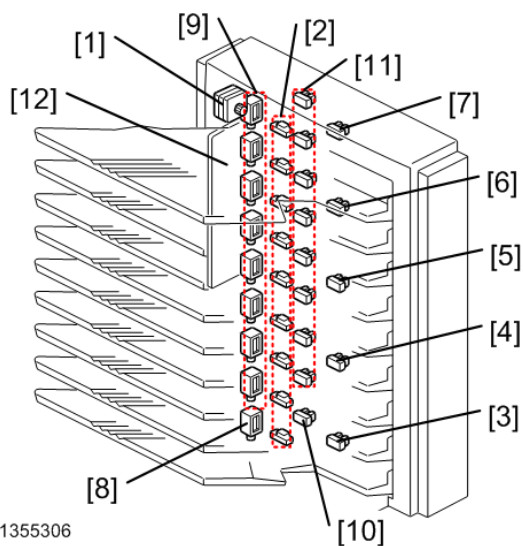

d1355306

Name	Function
1: Main Motor	Drives all the rollers in the unit
2: Tray Sensor (tray 1) ~ (Tray 9)	Detects paper in tray 1 ~ 9
3: Vertical Transport Sensor 1	Detects misfeeds (located between trays 1 and 2)
4: Vertical Transport Sensor 2	Detects misfeeds (located between trays 3 and 4)
5: Vertical Transport Sensor 3	Detects misfeeds (located between trays 5 and 6)
6: Vertical Transport Sensor 4	Detects misfeeds (located between trays 7 and 8)
7: Vertical Transport Sensor 5	Detects misfeeds (located at the exit to tray 9)
8: Junction Gate Solenoid 1	Opens/closes the junction gate at the entrance to the mailbox
9: Junction Gate Solenoids 2-9	Opens/closes the junction gates for trays 1-8.
10: Paper Tray Full Sensor 1	Detects paper full in tray 1.
11: Paper Tray Full Sensor 2-9	Detects paper full in trays 2 to 9. (cannot detect A5)
12: Controller Board	Controls the unit.

## 26.2 DETAILS

### 26.2.1 BASIC OPERATION

This 9-pin mailbox connects electrically to the finisher with a 14-pin drawer connector. When a print job starts, the main motor drives to rotate all rollers, and the specified bin receives the paper.

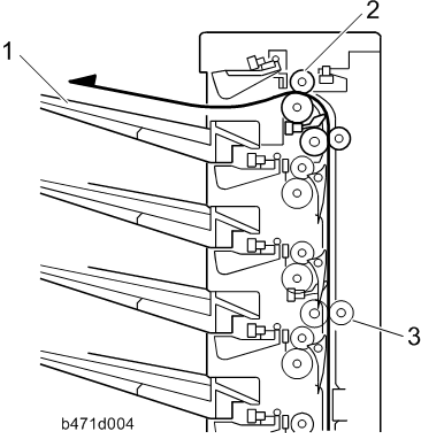

- 265. 9 Bin Tray
- 266. Exit Roller
- 267. Transport Roller

When the junction gate solenoid turns on, the gate switches and the tray receives the paper. When the uppermost tray is selected, all solenoids stay off. When the last paper's trailing edge passes the overflow sensor and the sensor turns off, the paper has gone to the tray, so the selected tray's junction gate solenoid and the main motor turn off. Normally, the speed of paper transport in this unit is nearly the same as in the finisher.

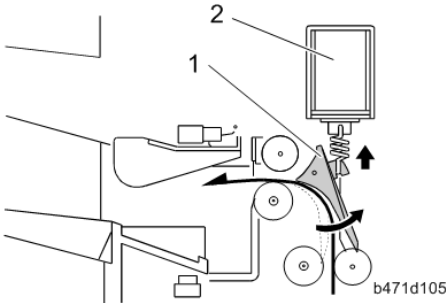

- 268. Junction Gate
- 269. Junction Gate Solenoid

### 26.2.2 PAPER TRAY FULL DETECTION

Each bin has a paper overflow sensor and it monitors each tray so that it does not become overloaded.

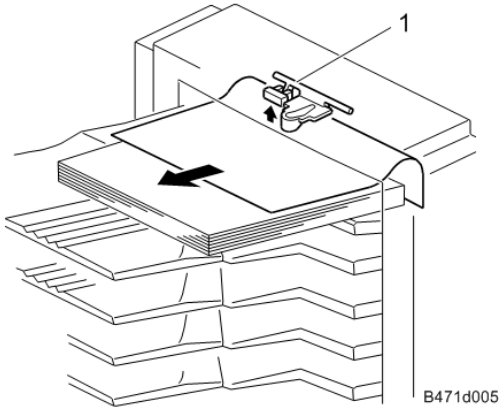

270. Tray Full Sensor

#### Paper Tray Full Detection Timing

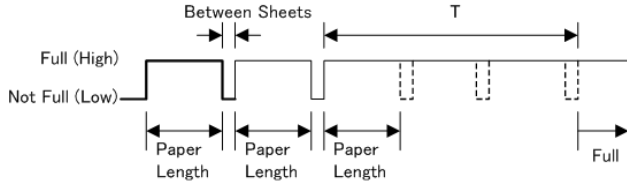

When output from the paper overflow sensor is more than (T) seconds at the "High" level, full detection will occur.

For example, at the lowest PPM (12 sheets / A3), when the sensor doesn't switch to "Low" by 40 sec after the detection, the print job will be stopped.

The machine determines the following depending on the result of the detection and the machine state.

Judge	Machine State	Trigger
Full	While receiving paper	Output 8 sheets of paper in a row in the same tray while the paper overflow sensor remains ON.
	In all states other than receiving paper (with door closed, no jam, and no remaining paper)	The sensor stays on for more than 1.5 sec.
Not Full	-	The sensor turns OFF

### 26.2.3 JAM DETECTION

Jam is detected with the five sensors in the picture below;

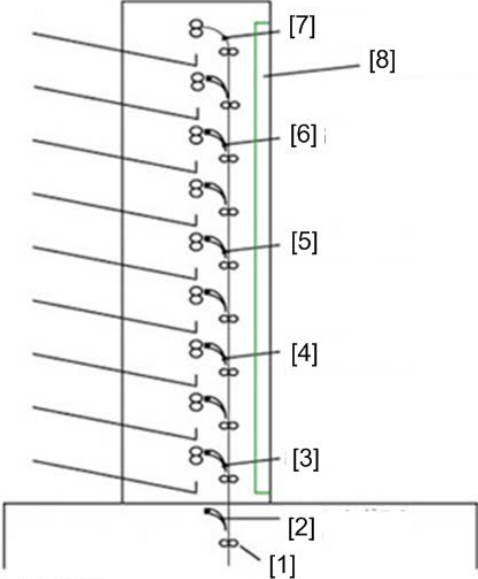

d1355308

- 271. Finisher Exit Roller
- 272. Entrance Junction Gate (CS4010)
- 273. Vertical Transport Sensor
- 274. Vertical Transport Sensor 2
- 275. Vertical Transport Sensor 3
- 276. Vertical Transport Sensor 4
- 277. Vertical Transport Sensor 5
- 278. Open/Close Guide Plate

**Jam Detection Details**

Jam Name	Detection Trigger	Logging Code
Transport Sensor 1 Late Jam	Even though paper moves "pulse x 1.5" ("distance L") from the finisher exit roller, the vertical transport sensor 1 in the 9-bin mailbox doesn't turn ON.	350
Transport Sensor 1 Lag Jam	(No Change)	351
Transport Sensor 2 Late Jam	(No Change)	352
Transport Sensor 2 Lag Jam	(No Change)	353
Transport Sensor 3 Late Jam	(No Change)	354
Transport Sensor 3 Lag Jam	(No Change)	355
Transport Sensor 4 Late Jam	(No Change)	356
Transport Sensor 4 Lag Jam	(No Change)	357
Transport Sensor 5 Late Jam	(No Change)	358
Transport Sensor 5 Lag Jam	(No Change)	359
Main Machine Ordering Data-Wrong Jam	Cannot continue to receive paper because the ordering data from the main machine is wrong or rebooting is demanded because paper reception is unavailable.	360

## 27. DECURLER UNIT DU5020

### 27.1 OVERVIEW

#### 27.1.1 GENERAL SPECIFICATIONS

Item	Descriptions	Remarks
Configuration	External (Optional) Console	
Power Source	5.1V $\pm$ 3%, 24V $\pm$ 5%	Supplied from the main machine
Power Consumption	30W or less	
Dimensions	170(W) x 730(D) x 990(H)	
Weight	30kg or less	

Decurler Unit				
Sheet Capacity	No stacking, paper passing only			
Passable Paper Size	331 x 488mm (13"x19.2") ~ A6T / Letter			
Supported Paper Thickness	40g/m2 ~ 300g/m2			40g/m2 is Ricoh-designated paper only
Supported Paper Type	Plain (including color dedicated paper), Recycled, Colored, Coated, Letterhead, Leathac, Indexed (tab), Backing, Labeled, Envelope, Pre-punch, Bond, Film, Crimped, Already-Printed paper			
Direction of Decurl	Face curl / Back curl			
Curl Amount after Decurling	Thickness	Basis Weight (g/m2)	EP/SP-A, B	AP
	Thin	40~51	-	
	Plain	52~105	$\pm$ 5mm or less More than R40mm	$\pm$ 15mm or less More than R40mm
	Middle Thick	106~163	-	
	Thick 1	164~216	-	
	Thick 2	217~256	-	
	Thick 3	257~300	-	

**Comment [ n 83]:** As you say, this unit doesn't have a purge function. Instead of this unit, the main machine has a purge function. And this unit also doesn't have a store for an used toner spare bottle.

So I deleted some descriptions.

**Comment [ n 84]:** RE: a kind of fancy paper (Leather + Like = Leathac). In Japanese “レザーック”. It's rather like product name. Maybe used only in Japan. So I think you may not need to write it in TTP.

Purge Tray		
Sheet Capacity	10 Sheets	A4 LEF, 81.4g / m2
Paper Size Capacity	331x488mm(13"x19.2") ~ A6 SEF/Letter	
Paper Thickness Capacity	40~300g/m2	40g/m2 (Ricoh-designated paper)
Supported Paper Type	Plain (including color dedicated paper), Recycled, Colored, Coated, Letterhead, Leathac, Indexed (tab), Backing, Labeled, Envelope, Pre-punch, Bond, Film, Crimped, Already-Printed paper	

### 27.1.2 ELECTRICAL COMPONENTS

**Comment [オフライン85]:** Please modify the diagrams – no purge tray

3/15  
Diagram renewed

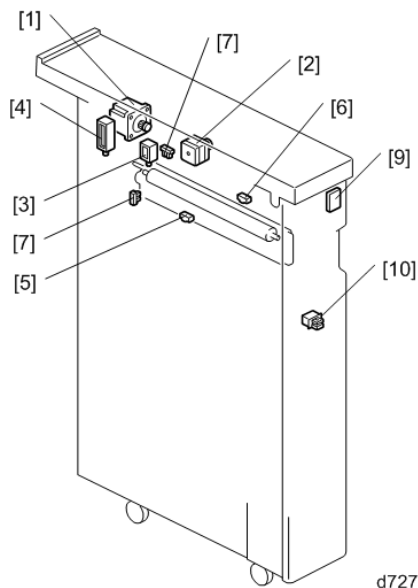

d7279001

Name	Role
1: Transport Motor	Drives the entrance rollers, the exit rollers, and the decurler rollers.
2: Decurl Pressure Adjustment Motor	Adjusts the strength of the pressure of the decurler rollers.
3: Exit Guide Solenoid	Opens the exit guide plate when jam detection occurs downstream.
4: Entrance Sensor	The sensor is 9.8mm before the entrance roller in order to detect paper coming from the print engine.
5: Exit Sensor	Installed 11.8mm before the exit roller.
6: Soft Roller HP Sensor	Detects the home position for the control mechanism of decurl pressure. The control is done after the roller

	returns to the home position.
7: Decurler Roller Unit Set Sensor	Detects whether the roller unit is installed or not.
8: Front Door Jam LED	Lights when a jam occurs.
9: Inner Jam LED	Lights when paper is in the purge tray. It cannot be seen unless the front cover is open.
10: Front Door SW	Interlock switch. Detects when the front cover opens/closes. When the cover is open, the 24V power supply stops.

## 27.2 MECHANISM DETAILS

### 27.2.1 DECURLER ROLLER UNIT

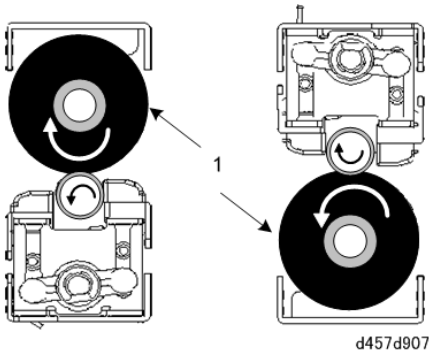

279. Soft Roller

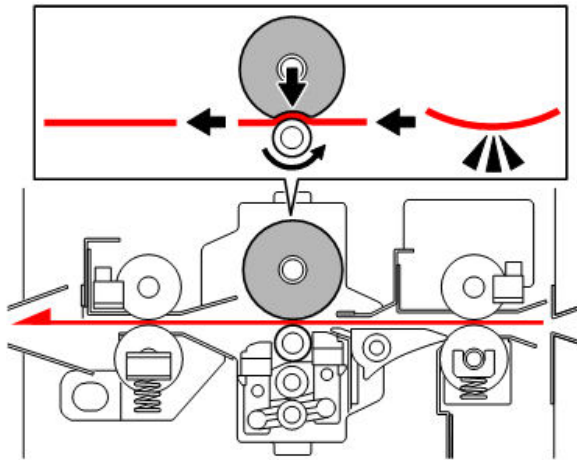

D457D105.jpg

Mechanism Details

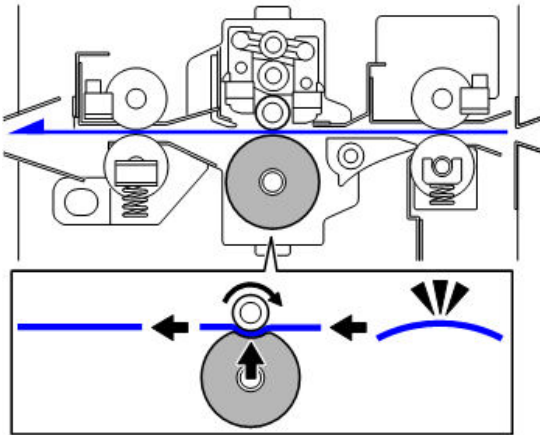

D457D106.jpg

To correct concave curling, the soft roller in the decurler roller unit is located on the upper side to let paper pass under the roller. To correct convex curling, the soft roller is located on the lower side to let paper pass over the roller.

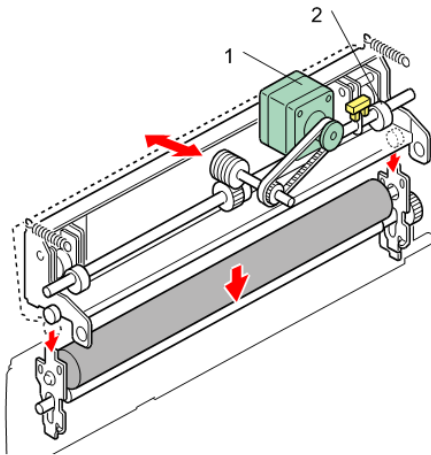

d457d107

- 280. Soft Roller HP Sensor
- 281. Press Switch Motor

The decurl pressure adjustment motor drives the cam that drives the roller bracket through the gear, which pushes the soft roller in on the metal roller. The soft roller HP sensor detects the cam when the soft roller is released.

## 28. MULTI-FOLDING UNIT FD 4000

### 28.1 OVERVIEW

#### 28.1.1 GENERAL LAYOUT

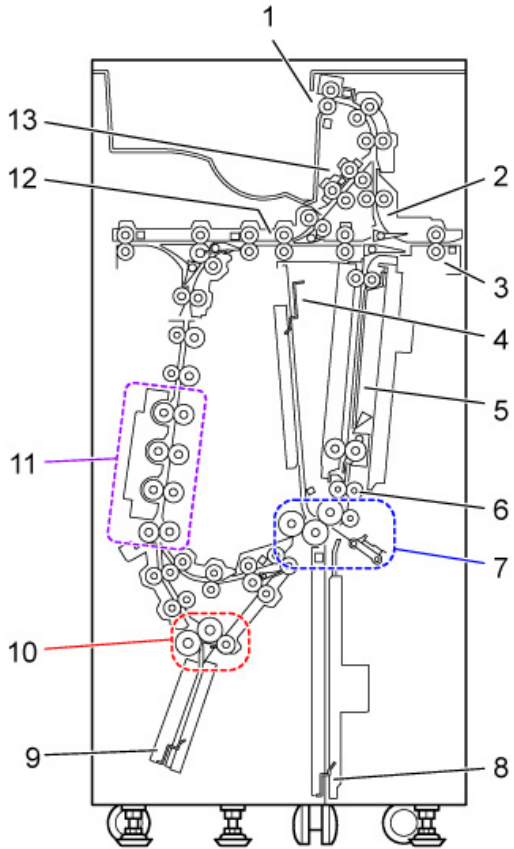

D6150100

- |                                |                          |
|--------------------------------|--------------------------|
| 1. Top Tray Exit               | 8. 1st Stopper Part      |
| 2. Mixed-Size Flat Paper Part  | 9. 3rd Stopper Part      |
| 3. Entrance Transport Part     | 10. 2nd Fold Part        |
| 4. 2nd Stopper                 | 11. Crease Part          |
| 5. Vertical Transport Part     | 12. Horizontal Transport |
| 6. Registration Transport Part | 13. Top Tray Transport   |
| 7. 1st Fold Part               |                          |

## 28.1.2 TRANSPORT LAYOUT

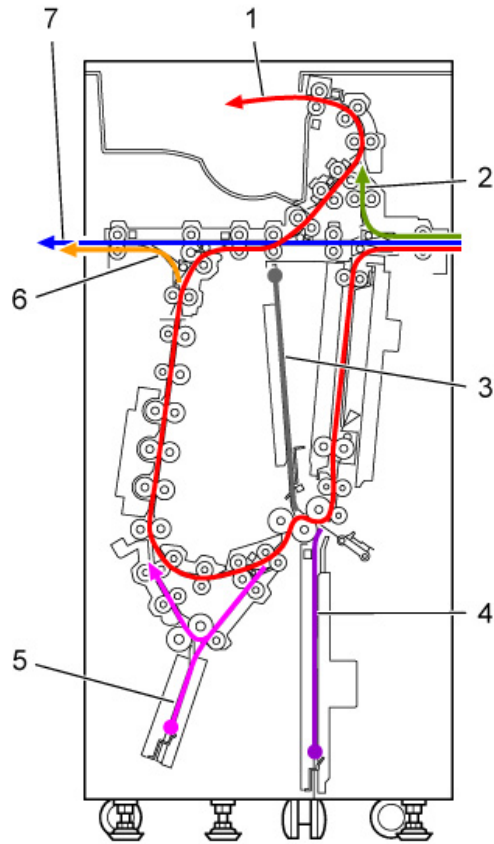

D6150101

- 1. Paper Fold Transport Path (Top Tray Output)
- 2. Mixed-Size Flat Paper Path
- 3. 2nd Stopper Transport Path
- 4. 1st Stopper Transport Path
- 5. 3rd Stopper Transport Path
- 6. Folded Paper Exit Path (to downstream-process [optional finisher])
- 7. Straight Through Path

### 28.1.3 ROLLER LAYOUT

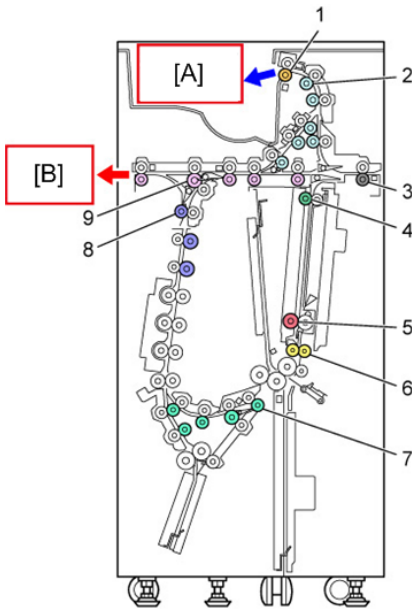

D6150102

A: Fold Paper Tray (Top Tray)

B: For Straight Through Path or For Downstream-process path

1. Top Tray Exit Roller

6. Registration Transport Roller

2. Top Tray Transport Roller

7. Bypass Transport Roller

3. Entrance Transport Roller

8. Vertical Transport Roller

4. Vertical Transport Roller

9. Horizontal Transport Roller

5. Vertical Transport Roller  
(Dynamic)

Overview

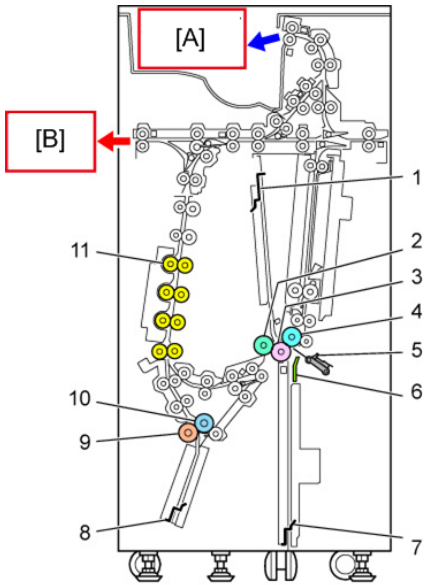

D6150103

A: Fold Paper Tray (Top Tray)  
B: For Straight Through Path or For Downstream-process path

- 1. 2nd Stopper
- 2. 3rd Fold Roller
- 3. 2nd Fold Roller
- 4. 1st Fold Roller
- 5. Fold Plate
- 6. Jogger Fence
- 7. 1st Stopper
- 8. 3rd Stopper
- 9. 5th Fold Roller
- 10. 4th Folding Roller
- 11. Crease Roller x 4

### 28.1.4 TRANSPORT SENSOR LAYOUT

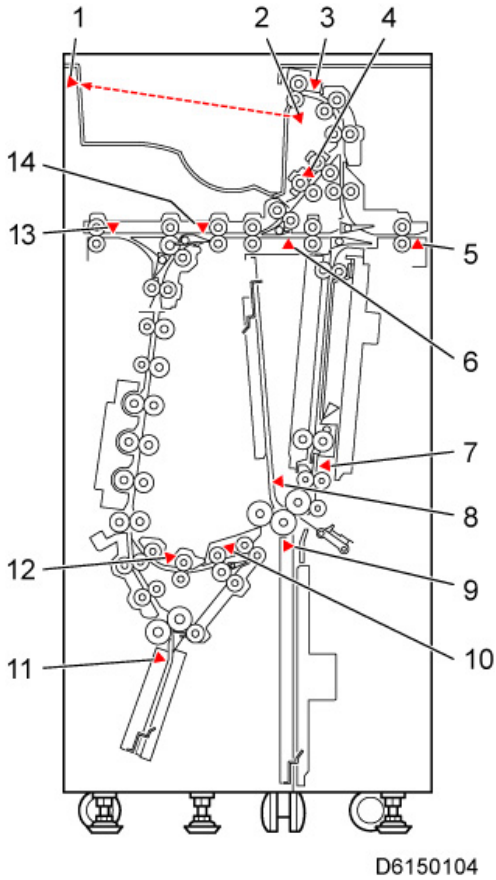

- |   |  |
|---|--|
| 1. Tray Full Sensor (Receiver)              | 8. 2nd Stopper Paper-Face Sensor                     |
| 2. Tray Full Sensor (Emitter)               | 9. 1st Stopper Paper-Face Sensor                     |
| 3. Top Tray Exit Sensor                     | 10. Bypass Entrance Paper-Remain Sensor              |
| 4. Top Tray Transport Paper-Remain Sensor   | 11. 3rd Stopper Paper-Face Sensor                    |
| 5. Entrance Sensor                          | 12. Bypass Paper Remain Sensor                       |
| 6. Horizontal Transport Paper-Remain Sensor | 13. Horizontal Exit Sensor                           |
| 7. Registration Sensor                      | 14. Horizontal-Reverse-Transport Paper-Remain Sensor |

### 28.1.5 DRIVE / SOLENOID LAYOUT

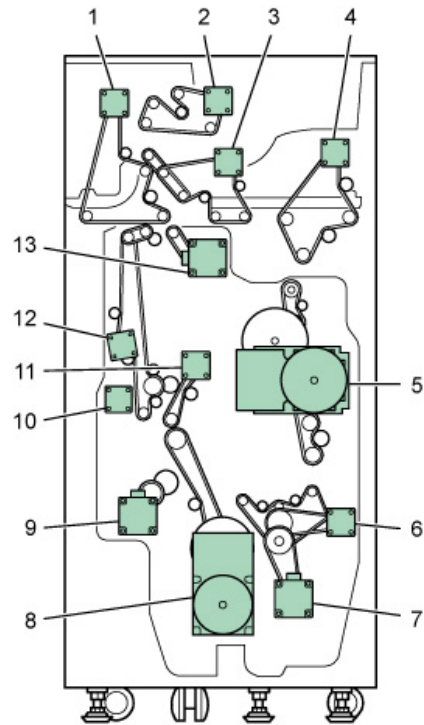

#### D6150105

- 1. Horizontal Transfer Motor
- 2. Top Tray Exit Motor
- 3. Top Tray Transfer Motor
- 4. Horizontal Exit Motor
- 5. Crease Motor
- 6. Double-Pawl Drive Motor
- 7. 2nd Fold Motor
- 8. 1st Fold Motor
- 9. Fold Plate Motor
- 10. Registration Roller Transport Motor
- 11. Registration Roller Release Motor
- 12. Dynamic Roller Transport Motor
- 13. Dynamic Roller Up-Down Motor

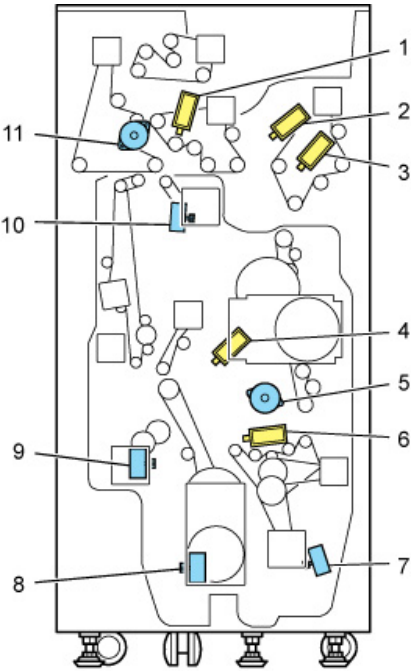

D6150106

- 1. TopTray Junction gate Pawl Solenoid
- 2. Reverse-Transport Pawl Solenoid
- 3. Exit Junction gate Pawl Solenoid
- 4. Leading Edge Stop Pawl Solenoid
- 5. Direct Send Junction Gate Motor
- 6. Bypass Junction Gate Pawl Solenoid
- 7. 3rd Stopper Motor
- 8. 1st Stopper Motor
- 9. Jogger Shift Motor
- 10. 2nd Stopper Motor
- 11. Entrance Junction gate Pawl Motor

## 28.1.6 ELECTRICAL COMPONENT LAYOUT (TRANSPORT)

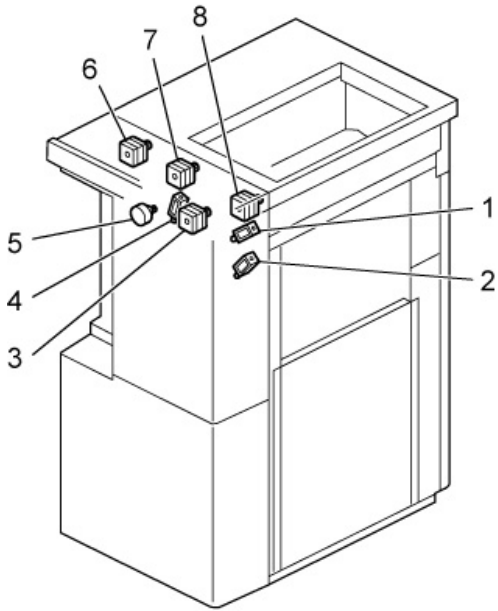

D6150901

- |  |                                      |
|--|--------------------------------------|
| 1. Reverse Junction Gate Pawl Solenoid | 5. Entrance Junction Gate Pawl Motor |
| 2. Exit Junction Gate Pawl Solenoid    | 6. Horizontal Transport Motor        |
| 3. Top Tray Transport Motor            | 7. Top Tray Exit Motor               |
| 4. Top Tray Junction Gate Solenoid     | 8. Horizontal Exit Motor             |

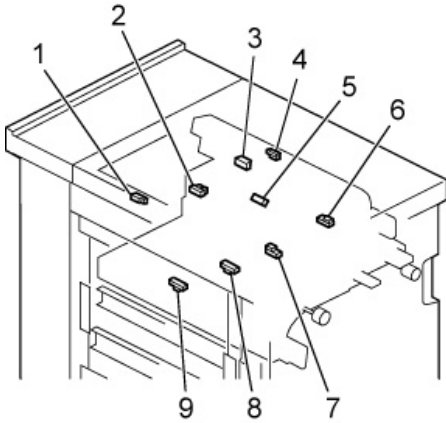

D6150902

- |   |  |
|---|--|
| 1. Tray Full Sensor (Receiver)            | 6. Entrance Sensor                             |
| 2. Entrance Junction Gate Pawl HP Sensor  | 7. Horizontal Transport Paper-Remain Sensor    |
| 3. Top Tray Exit Sensor                   | 8. Horizontal Reverse-Send Paper-Remain Sensor |
| 4. Top Tray Transport Paper-Remain Sensor | 9. Horizontal Exit Sensor                      |
| 5. Tray Full Sensor (Emitter)             |  |

### 28.1.7 ELECTRICAL COMPONENTS LAYOUT (VERTICAL TRANSPORT)

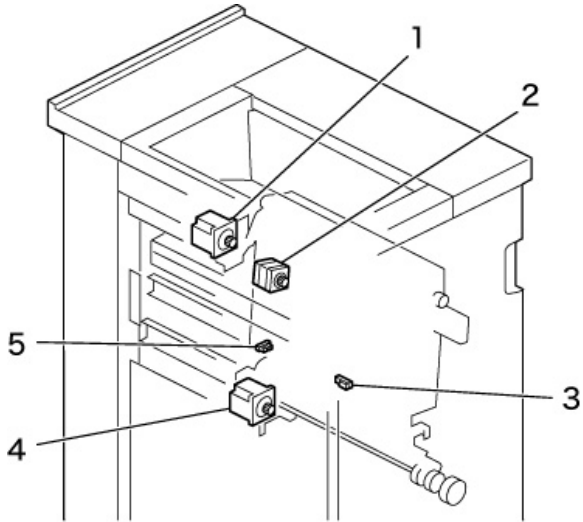

D6150904

- 1. Dynamic Roller Up-down Motor
- 2. Dynamic Roller Transport Motor
- 3. Registration Motor
- 4. Fold Plate Motor
- 5. Dynamic Roller HP Sensor

### 28.1.8 ELECTRICAL COMPONENTS LAYOUT (1ST, 2ND, 3RD, STOPPER)

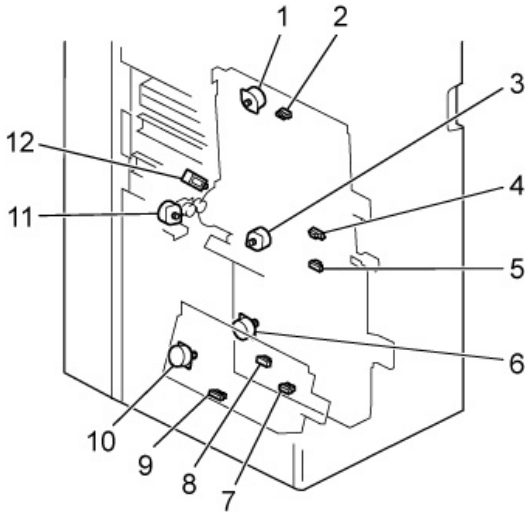

D6150903

1. 2nd Stopper Motor	7. 1st Stopper HP Sensor
2. 2nd Stopper HP Sensor	8. 3rd Stopper Paper-Face Sensor
3. Jogger Shift Motor	9. 3rd Stopper HP Sensor
4. 2nd Stopper Paper-Face Sensor	10. 3rd Stopper Motor
5. 1st Stopper Paper-Face Sensor	11. Direct Send Pawl Sensor
6. 1st Stopper Motor	12. Leading Edge Stop Pawl Solenoid

### 28.1.9 ELECTRICAL COMPONENTS LAYOUT (REGISTRATION, 1ST FOLD)

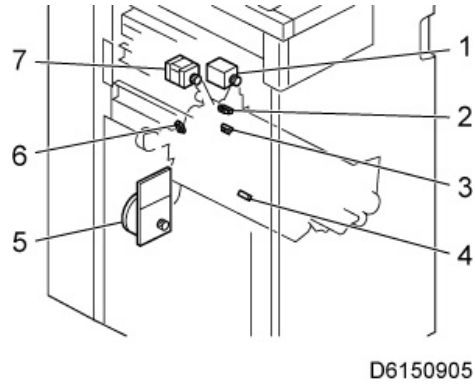

- |  |  |
|--|--|
| 1. Registration Roller Release Motor     | 5. 1st Fold Motor                      |
| 2. Registration Roller Release HP Sensor | 6. Direct Send Pawl HP Sensor          |
| 3. Fold Plate HP Sensor                  | 7. Registration Roller Transport Motor |
| 4. Bypass Entrane Paper Remain Sensor    |  |

### 28.1.10 ELECTRICAL COMPONENTS (2ND FOLD, CREASE)

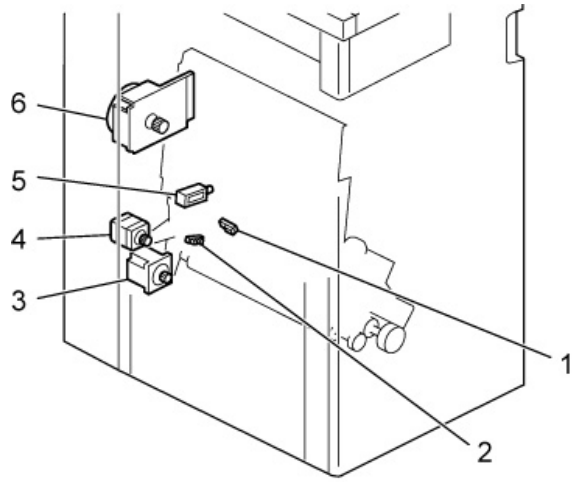

D6150906

- 1. Bypass Exit Paper Remain Sensor
- 2. Double Pawl HP Sensor
- 3. 2nd Fold Motor
- 4. Double Pawl Motor
- 5. Bypass Junction Gate Pawl Solenoid
- 6. Crease Motor

### 28.1.11 ELECTRICAL COMPONENTS (ELECTRICAL PARTS)

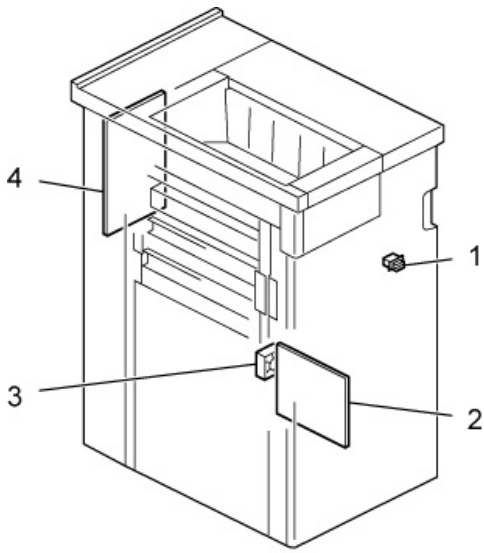

D6150907

1. Front Cover Switch  
2. PSU

3. PSU Fan  
4. Main Controller Board

## 28.2 DETAILS

### 28.2.1 FOLD PROCESS

#### ◆ Single Sheet Fold Mode

The leading edge of paper bumps on the stopper pawl [A] but goes further to make deflection on its face. Then the deflected part is fed into the fold roller nip [B] and the fold is formed.

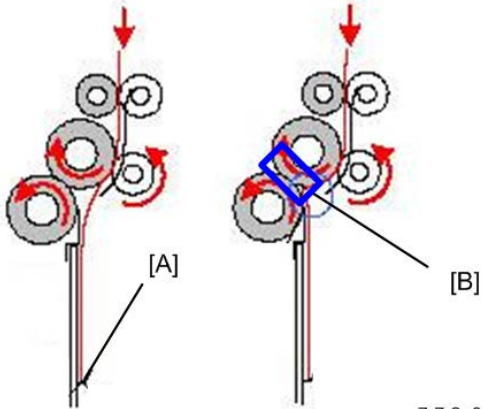

7-7-2\_006

#### ◆ Double Sheet Fold Mode

One, two, or three sheet(s) of paper is (are) stacked on the pre-stack part. At this time, the transport roller that makes a deflection on paper is evacuated so no deflection is made. The fold plate [A] moves forward to press paper into the roller nip [B]. Paper goes into the roller nip while being folded.

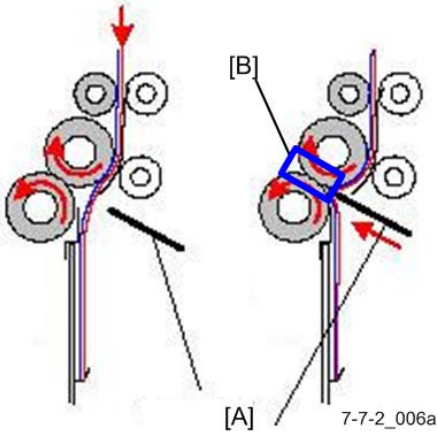

7-7-2\_006a

### 28.2.2 EACH FOLD OPERATION

	1st Stopper Location	Fold Plate	2nd Stopper Location	3rd Stopper Location	Output
Z-Fold	Through		Short	Short	
Half-fold	1/2	o	Through	Through	Fold Output
Letter Fold-in	Long	o	Long	Through	Fold Output
Letter Fold-out	Short	o	Long	Through	Fold Output
Double-parallel Fold	1/2		1/2	Through	Fold Output
Gate Fold	Long		Long	1/2	Fold Output

\*The fold plate is used only in double fold.

- Z-Fold**  
 Paper passes through the 1st folding part [A] without any treatment and bumps onto the 2nd stopper [B] to make a deflection on itself. With this deflection, paper is fed into the 2nd-fold part nip and 1st fold is made. Then paper bumps onto the 3rd stopper [C] where paper is fed into to form 2nd fold. Finally Z-fold is formed.

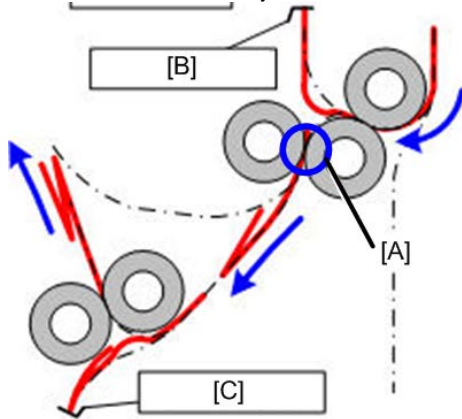

7-7-3\_001-1

- Half-fold**  
**Single Sheet Fold:** paper bumps onto the 1st stopper [A] and makes a deflection on itself near the 1st fold nip [B]. With this deflection, paper is fed into the 1st fold nip [B] to be half-folded.  
**Double Sheet Fold:** 1 to 3 sheet(s) of paper is (are) pre-stacked while bumping onto the 1st stopper [A]. The fold plate [C] presses paper into the 1st fold nip [B] and paper is folded to be double half-fold paper.

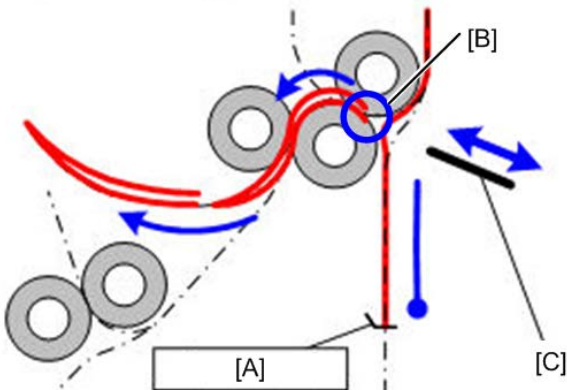

7-7-3\_001-2

- Letter Fold-in [1] / Letter Fold-out [2] / Double-parallel Fold [3]  
**Single Sheet Fold:** Paper bumps onto the 1st stopper [A] to make a deflection on itself near the 1st fold nip [B]. With this deflection, paper is fed into the 1st fold nip [B] and 1st fold is formed. Then paper bumps onto the 2nd stopper [C] and 2nd fold is formed at the 2nd fold nip [D]. At this time, the location of the 1st stopper [A] and the 2nd stopper [C] varies depending on the mode: Letter Fold-in / Letter Fold-out / Double-parallel Fold.  
**Double Sheet Fold:** 1 to 3 sheet(s) of paper is (are) pre-stacked while bumping onto the 1st stopper [A]. The fold plate [E] presses paper into the 1st fold nip [B] and 1st-fold is formed. The following steps are same as the steps in single sheet fold.

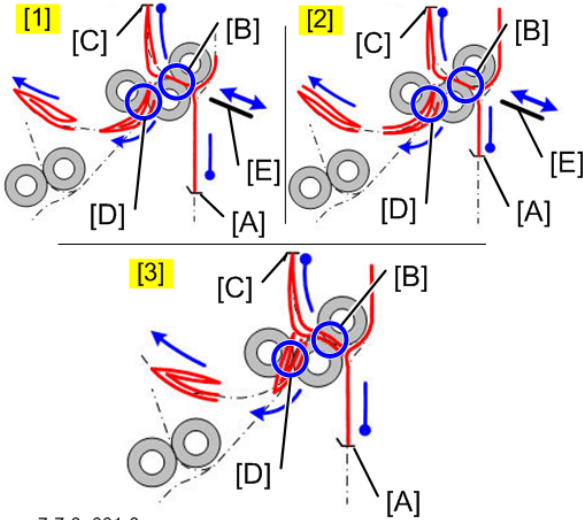

7-7-3\_001-3

- Gate Fold  
 Paper bumps onto the 1st stopper [A] to make a deflection on itself near the 1st fold nip [B]. With this deflection, paper is fed into the 1st fold nip [B] and 1st fold is formed. After that, paper bumps onto the 2nd stopper [C] and 2nd fold is made at the 2nd fold nip [D]. After passing through the 2nd fold nip, paper bumps onto the 3rd stopper [E] and 3rd fold is made at the 3rd fold nip [F] and double gate-fold is formed.

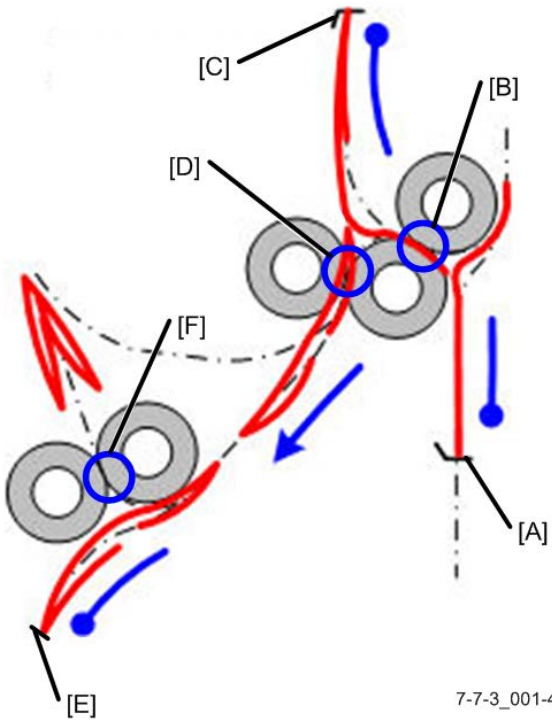

7-7-3\_001-4

### 28.2.3 DOUBLE FOLD

\*Mixed-loading is available within the range 55K ~ 70K

- 282. The 1st paper goes into the pre-stack area which includes the TE stopper pawl [A] and the 1st stopper [B].
- 283. Paper pushes the TE stopper pawl [A] aside and open it to pass by. The pawl [A] moves up when paper passes through a certain amount.
- 284. At the time when the trailing edge of paper goes off the TE stopper pawl [A], the pawl [A] switch its pawl to close.

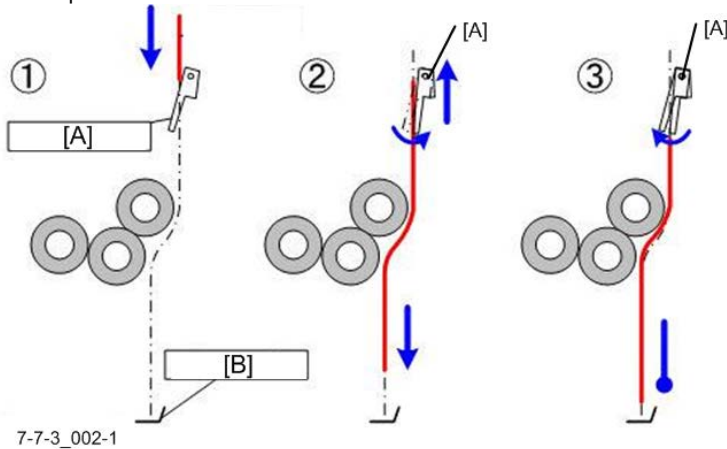

- 285. The leading edge of the 1st paper reaches the 1st stopper [B] and the TE stopper pawl [A] switches its pawl to close in order not for the leading edge of the 2nd paper to bump onto the trailing edge of the 1st paper. The 2nd paper goes into the pre-stack area.
- 286. As the "step 2", the 2nd paper begins to go into the pre-stack area while pushing the TE stopper pawl [A] out. Then the pawl [A] moves up at the timing when a certain amount of the 2nd paper goes into.
- 287. As the "step 3", when the trailing edge of the 2nd paper goes off the TE stopper pawl [A], the pawl [A] switch its pawl to close.

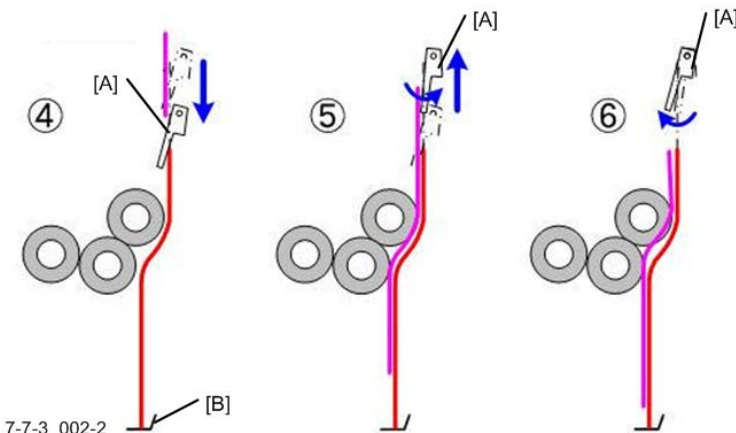

- 288. The 3rd paper comes and the same operation (step.4 ~ 6) is applied to it.
- 289. After 1 to 3 sheet(s) of paper is (are) stacked on the pre-stack part, the fold plate [A] moves forward to press paper into the direction of the roller nip [B] to fold the stack.

Details

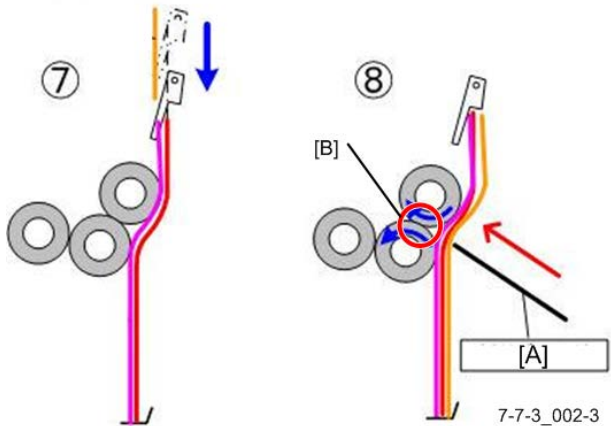

## 28.3 FOLD ADJUSTMENT

### 28.3.1 FOLD MEASUREMENT LOCATION

Mark the top face of folded stack on the top exit tray. Then keep the folded part on the paper stretched to measure the length of L1, L2, and L3. If there is wrong, correct a skew of the 1st, the 2nd, and the 3rd stopper.

- Direction of a folded sheet stack on the top tray

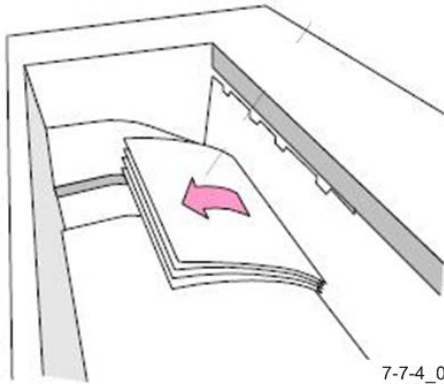

7-7-4\_001-1

- Definition of the areas you should measure

----- Mountain Fold

----- Valley Fold

① Folded with 1st stopper

② Folded with 2nd stopper

③ Folded with 3rd stopper

Letter Fold-out

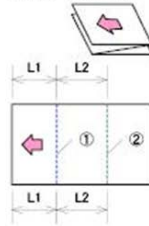

Letter Fold-in

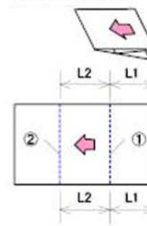

Z-fold

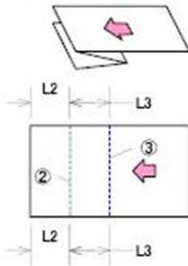

Half-fold

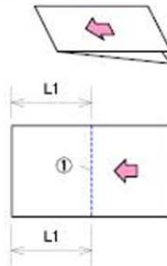

Double-parallel Fold

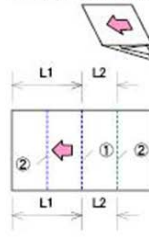

Gate Fold

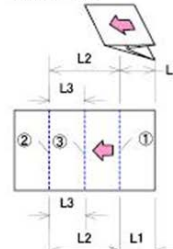

w\_7-7-4\_001-1

- Foldtype-Catagolized Adjustment List

	L1	L2	L3	1st Stopper	2nd Stopper	3rd Stopper
Z-Fold	-	F Long	F Long	-	F Lower	F Raise
	-	F Short	F Short	-	F Raise	F Lower

Fold Adjustment

Half-fold	F Long	-	-	F Raise	-	-
	F Short	-	-	F Lower	-	-
Letter Fold In	F Long	F Long	-	F Raise	F Lower	-
	F Short	F Short	-	F Lower	F Raise	-
Letter Fold Out	F Long	F Long	-	F Lower	F Lower	-
	F Short	F Short	-	F Raise	F Raise	-
Double-Parallel Fold	F Long	F Long	-	F Raise	F Lower	-
	F Short	F Short	-	F Raise	F Raise	-
Gate Fold	F Long	F Long	F Long	F Lower	F Lower	F Raise
	F Short	F Short	F Short	F Raise	F Raise	F Lower

When fold operation finishes, it is difficult to determine which stopper to be adjusted even if you measure a skew of a fold end (Excluding half-fold case). So confirm the direction of a skew by measuring the length of each fold while paper is spreaded out.

\*Except the case of half-fold mode, you need to determine which stopper to be adjusted from the length of the 1st fold part that affects following fold parts.

### 28.3.2 CREASE ROLLER ADJUSTMENT

Detach the screw [A] to move the pressure adjustment bracket [B] that affects the length of the pressure spring [C].

- **To strengthen the pressure:** Move the bracket [B] up
- **To weaken the pressure:** Move the bracket [B] down

After the adjustment, attach the screw on the other hole [D] to fix the location of the pressure adjustment bracket [B].

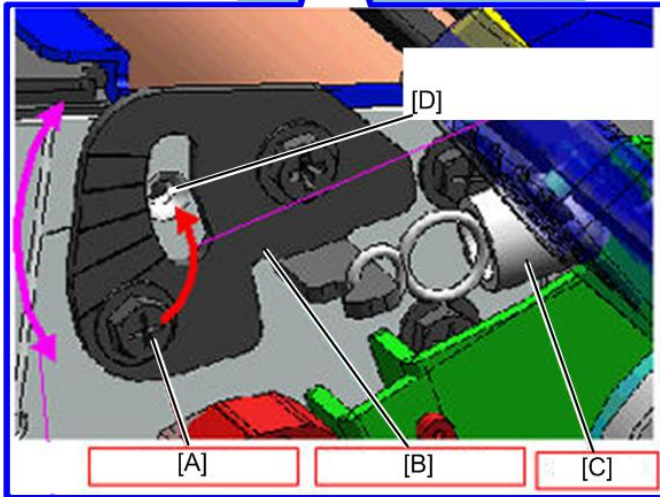
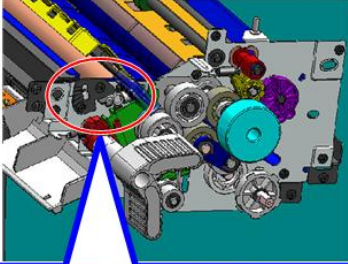

7-7-4\_003

### 28.3.3 FOLD-AREA ADJUSTMENT

#### 1) Z-Fold

##### User Tool Setting

Input the change value (S) for the fold area with the operation panel;

Size	Set Area	Default	Value Range
A3 SEF	S	0mm	±10mm
B4 SEF	S	0mm	±10mm
A4 SEF	S	0mm	±10mm
DLT	S	0mm	±10mm
LG	S	0mm	±10mm
LT SEF	S	0mm	±10mm
Others	S	0mm	±10mm
Adjustment Pitch	1mm		

Adjust with SP mode\*1,3, user setting\*2, operator adjustment\*3, special operator adjustment\*3.  
Input the adjustment value for fold size (L, S) with the operation panel.

Size	Set Area	Default	Value Range
A3 SEF	S	0mm	±4mm
B4 SEF	S	0mm	±4mm
A4 SEF	S	0mm	±4mm
DLT	S	0mm	±4mm
LG	S	0mm	±4mm
LT SEF	S	0mm	±4mm
12"×18"	S	0mm	±4mm
8k	S	0mm	±4mm
13"×19"	S	0mm	±4mm
Others	S	0mm	±4mm
Adjustment Pitch	0.2mm		

\*1 FD4000

\*2 FD5010: For single fold

\*3 FD5010: For Double fold

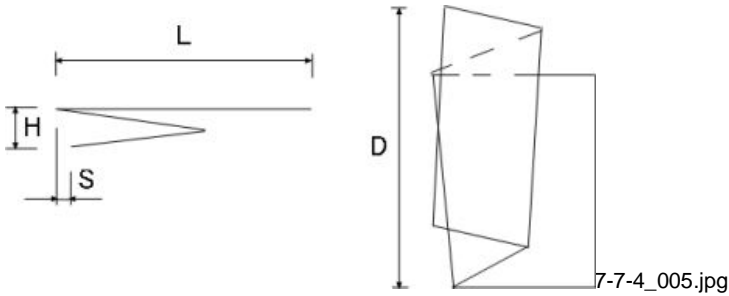

2) Half-fold

User Tool Setting

Input the change value (S) for a fold area with the operation panel;

Size	Set Area	Default	Value Range
A3 SEF	S	0mm	±10mm
B4 SEF	S	0mm	±10mm
A4 SEF	S	0mm	±10mm
B5 SEF	S	0mm	±10mm
DLT	S	0mm	±10mm
LG	S	0mm	±10mm
LT SEF	S	0mm	±10mm
12×18	S	0mm	±10mm
8K	S	0mm	±10mm
Others	S	0mm	±10mm
Adjustment Pitch	1mm		

Adjust with SP mode\*1, 3, user setting\*2, operator adjustment\*3, special operator adjustment\*3.

Input the adjustment value for a fold area (S) with the operation panel.

Size	Set Area	Default	Value Range
13×19.2	S	0mm	-
13×19	S	0mm	-
12.6×19.2	S	0mm	-
12.6×18.5	S	0mm	±5mm
13×18	S	0mm	±10mm
SRA3	S	0mm	±10mm
SRA4	S	0mm	±10mm
226×310	S	0mm	±10mm
310×432	S	0mm	±10mm
A3 SEF	S	0mm	±10mm
B4 SEF	S	0mm	±10mm

## Fold Adjustment

A4 SEF	S	0mm	±10mm
B5 SEF	S	0mm	±10mm
DLT	S	0mm	±10mm
LG	S	0mm	±10mm
LT SEF	S	0mm	±10mm
12×18	S	0mm	±10mm
8K	S	0mm	±10mm
Others	S	0mm	±10mm
Adjustment Pitch	0.2mm		

\*1 FD4000

\*2 FD5010: For single fold

\*3 FD5010: For double fold

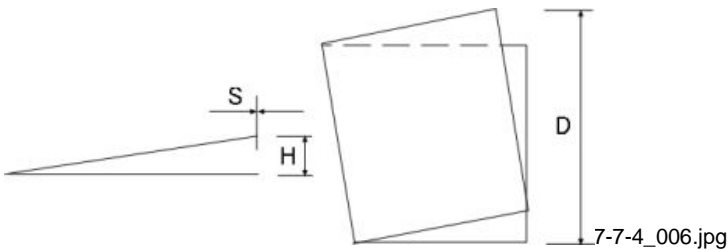

### 3) Letter Fold-in

#### User Tool Setting

Input the change value (S1) for a fold area with the operation panel;

Size	Set Area	Default	Value Range
A3 SEF	S1	4mm	±10mm
B4 SEF	S1	4mm	±10mm
A4 SEF	S1	4mm	±10mm
DLT	S1	4mm	±10mm
LG	S1	4mm	±10mm
LT SEF	S1	4mm	±10mm
12×18	S1	4mm	±10mm
8K	S1	4mm	±10mm
Others	S1	4mm	±10mm
Adjustment Pitch	1mm		

Adjust with SP mode\*1, 3, user setting\*2, operator adjustment\*3, special operator adjustment\*3.

Input the adjustment value for fold area (L, S2) with the operation panel.

Size	Set Area	Default	Value Range	Set Area	Default	Value Range
A3 SEF	L	0mm	±4mm	S2	0mm	±4mm

B4 SEF	L	0mm	±4mm	S2	0mm	±4mm
A4 SEF	L	0mm	±4mm	S2	0mm	±4mm
DLT	L	0mm	±4mm	S2	0mm	±4mm
LG	L	0mm	±4mm	S2	0mm	±4mm
LT SEF	L	0mm	±4mm	S2	0mm	±4mm
12×18	L	0mm	±4mm	S2	0mm	±4mm
8K	L	0mm	±4mm	S2	0mm	±4mm
Others	L	0mm	±4mm	S2	0mm	±4mm
Adjustment Pitch	0.2mm					

\*1 FD4000

\*2 FD5010: For single fold

\*3 FD5010: For double fold

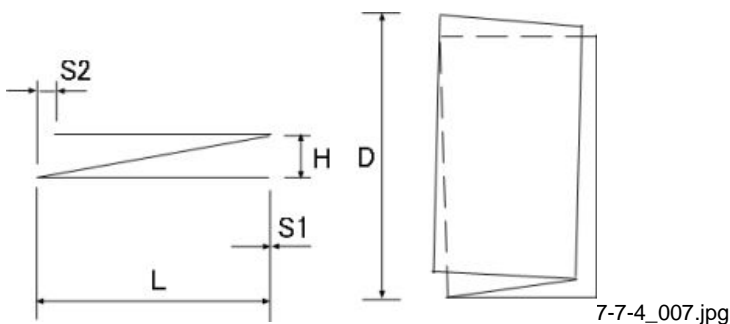

4) Letter Fold-in

User Tool Setting

Input the change value (S1) for a fold area with the operation panel;

Size	Set Area	Default	Value Range
A3 SEF	S1	2mm	2~7mm
B4 SEF	S1	2mm	2~7mm
A4 SEF	S1	2mm	2~7mm
B5 SEF	S1	2mm	-
DLT	S1	2mm	2~7mm
LG	S1	2mm	2~7mm
LT SEF	S1	2mm	2~7mm
12×18	S1	2mm	2~7mm
8K	S1	2mm	2~7mm
Others	S1	2mm	2~7mm
Adjustment Pitch	1mm		

Adjust with SP mode\*1, 3, user setting\*2, operator adjustment\*3, special operator adjustment\*3.

Input the adjustment value for fold area (L1, L2) with the operation panel.

## Fold Adjustment

Size	Set Area	Default	Value Range	Set Area	Default	Value Range
A3 SEF	L1	0mm	±4mm	L2	0mm	±4mm
B4 SEF	L1	0mm	±4mm	L2	0mm	±4mm
A4 SEF	L1	0mm	±4mm	L2	0mm	±4mm
B5 SEF	L1	0mm	±4mm	L2	0mm	±4mm
DLT	L1	0mm	±4mm	L2	0mm	±4mm
LG	L1	0mm	±4mm	L2	0mm	±4mm
LT SEF	L1	0mm	±4mm	L2	0mm	±4mm
12×18	L1	0mm	±4mm	L2	0mm	±4mm
8K	L1	0mm	±4mm	L2	0mm	±4mm
Others	L1	0mm	±4mm	L2	0mm	±4mm
Adjustment Pitch	0.2mm					

\*1 FD4000

\*2 FD5010: For single fold

\*3 FD5010: For double fold

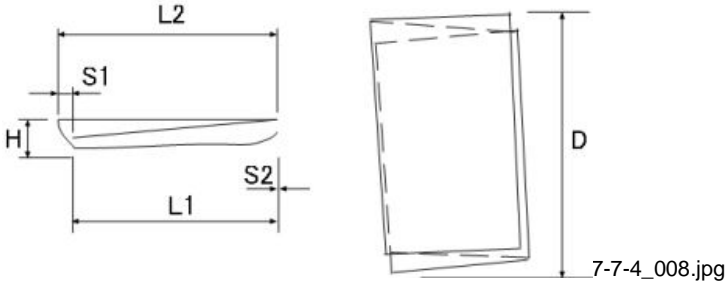

## 5) Double-parallel Fold

User Tool Setting

Input the change value (S1, S2) for a fold area with the operation panel;

Size	Set Area	Default	Value Range	Set Area	Default	Value Range
A3 SEF	S1	0mm	±10mm	S2	0mm	±10mm
B4 SEF	S1	0mm	±10mm	S2	0mm	±10mm
A4 SEF	S1	0mm	±10mm	S2	0mm	±10mm
B5 SEF	S1	0mm	±10mm	S2	0mm	±10mm
DLT	S1	0mm	±10mm	S2	0mm	±10mm
LG	S1	0mm	±10mm	S2	0mm	±10mm
LT SEF	S1	0mm	±10mm	S2	0mm	±10mm
12×18	S1	0mm	±10mm	S2	0mm	±10mm
8K	S1	0mm	±10mm	S2	0mm	±10mm
Others	S1	0mm	±10mm	S2	0mm	±10mm
Adjustment Pitch	1mm					

Adjust with SP mode\*1, 3, user setting\*2, operator adjustment\*3, special operator adjustment\*3.  
 Input the adjustment value for fold area (S1, S2) with the operation panel.

Size	Set Area	Default	Value Range	Set Area	Default	Value Range
A3 SEF	S1	0mm	±4mm	S2	0mm	±4mm
B4 SEF	S1	0mm	±4mm	S2	0mm	±4mm
A4 SEF	S1	0mm	±4mm	S2	0mm	±4mm
B5 SEF	S1	0mm	±4mm	S2	0mm	±4mm
DLT	S1	0mm	±4mm	S2	0mm	±4mm
LG	S1	0mm	±4mm	S2	0mm	±4mm
LT SEF	S1	0mm	±4mm	S2	0mm	±4mm
12x18	S1	0mm	±4mm	S2	0mm	±4mm
8K	S1	0mm	±4mm	S2	0mm	±4mm
Others	S1	0mm	±4mm	S2	0mm	±4mm
Adjustment Pitch	0.2mm					

- \*1 FD4000
- \*2 FD5010: For single fold
- \*3 FD5010: For double fold

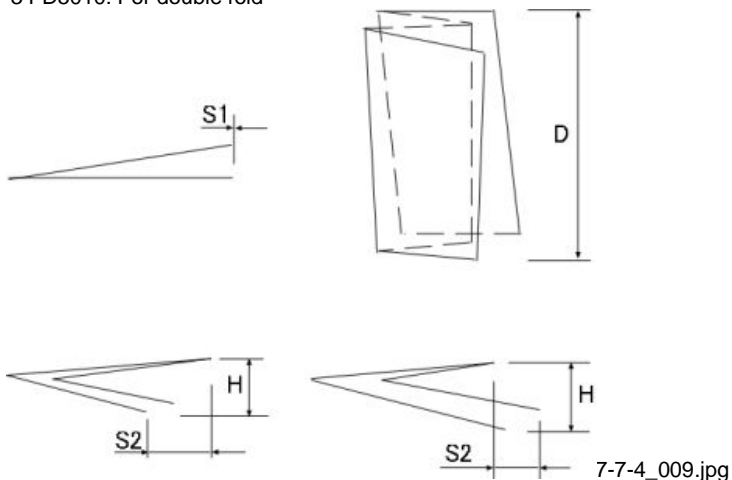

6) Gate Fold  
 User Tool Setting  
 Input the change value (S1, S2) for a fold area with the operation panel;

Size	Set Area	Default	Value Range
A3 SEF	S1 (S2)	2mm	2~12mm
B4 SEF	S1 (S2)	2mm	2~12mm
A4 SEF	S1 (S2)	2mm	2~12mm

## Fold Adjustment

B5 SEF	S1 (S2)	2mm	2~12mm
DLT	S1 (S2)	2mm	2~12mm
LG	S1 (S2)	2mm	2~12mm
LT SEF	S1 (S2)	2mm	2~12mm
12x18	S1 (S2)	2mm	-
8K	S1 (S2)	2mm	2~12mm
Others	S1 (S2)	2mm	2~12mm
Adjustment Pitch	1mm		

Adjust with SP mode\*1,3, user setting\*2, operator adjustment\*3, special operator adjustment\*3.  
Input the  $\pm$  adjustment value for fold area (S1, S2, S3) with the operation panel.

Size	Set Area	Default	Value Range	Set Area	Default	Value Range	Set Area	Default	Value Range
A3 SEF	S1	0mm	$\pm 4$ mm	S2	0mm	$\pm 4$ mm	S3	0mm	$\pm 4$ mm
B4 SEF	S1	0mm	$\pm 4$ mm	S2	0mm	$\pm 4$ mm	S3	0mm	$\pm 4$ mm
A4 SEF	S1	0mm	$\pm 4$ mm	S2	0mm	$\pm 4$ mm	S3	0mm	$\pm 4$ mm
B5 SEF	S1	0mm	$\pm 4$ mm	S2	0mm	$\pm 4$ mm	S3	0mm	$\pm 4$ mm
DLT	S1	0mm	$\pm 4$ mm	S2	0mm	$\pm 4$ mm	S3	0mm	$\pm 4$ mm
LG	S1	0mm	$\pm 4$ mm	S2	0mm	$\pm 4$ mm	S3	0mm	$\pm 4$ mm
LT SEF	S1	0mm	$\pm 4$ mm	S2	0mm	$\pm 4$ mm	S3	0mm	$\pm 4$ mm
12x18	S1	0mm	$\pm 4$ mm	S2	0mm	$\pm 4$ mm	S3	0mm	$\pm 4$ mm
8K	S1	0mm	$\pm 4$ mm	S2	0mm	$\pm 4$ mm	S3	0mm	$\pm 4$ mm
Others	S1	0mm	$\pm 4$ mm	S2	0mm	$\pm 4$ mm	S3	0mm	$\pm 4$ mm
Adjustment Pitch	0.2mm								

\*1 FD4000

\*2 FD5010: For single fold

\*3 FD5010: For double fold

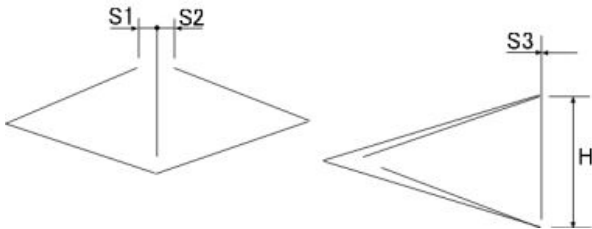

7-7-4\_010.jpg

Detach the stopper screw and then relocate it to the screw hole for adjustment before fix it loosely. After that, move the adjustment screw to adjust the tilt and then fasten the stopper screw to fix the location.

The location of each stopper screw and adjustment screw is shown below:

2nd Stopper Adjustment

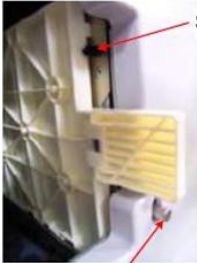

Stopper Screw



Adjustment Screw  
Right Rotation: Move Down  
Left Rotation: Move Up

1st Stopper Adjustment



Stopper Screw

Adjustment Screw  
Right Rotation: Move Down  
Left Rotation: Move Up

3rd Stopper Adjustment

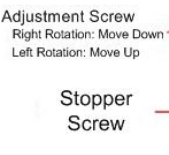

Adjustment Screw  
Right Rotation: Move Down  
Left Rotation: Move Up

Stopper Screw

w\_7-7-4\_002

## 29. LCIT RT4020

### 29.1 OVERVIEW

#### 29.1.1 SPECIFICATIONS

##### ◆ General

Item	Descriptions
Supported Paper Sizes	A4 (LEF), B5 (LEF), 8 <sup>1</sup> / <sub>2</sub> " x 11" (LEF)
Sheet Capacity	4,780 Sheets (When Ricoh MyPaper)
Supported Thickness (Paper Weight)	52.3 ~ 216.0g/m <sup>2</sup> (45~110kg)
Feed Method	FRR Method
Power Source	DC24V.5V (supplied from the main machine)
Max Power Consumption	50W or less (supplied from the main machine)
Dimensions (W x D x H)	352 x 458 x 625 mm
Weight	Approximately 20kg

##### ◆ Supported Sizes

A4 LEF, B5 LEF, LT LEF

\*No APS function (platen mode) for LT LEF

##### ◆ \*Supported Paper Thickness (Paper Weight)

45 K ~ 180K (R)      52.3 ~ 216.0 g/m<sup>2</sup> (gsm)

**Comment [ n 86]:** I deleted wrong LCIT's descriptions.

3/15

Japanese diagram fixed

### 29.1.2 LAYOUT

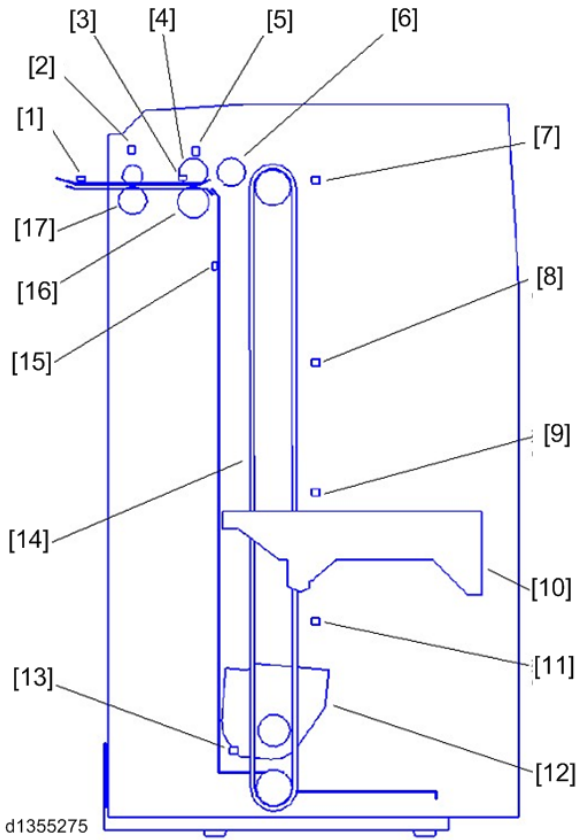

- 290. LCIT Relay Sensor
- 291. Slide Sensor (x 2)
- 292. Feed Sensor
- 293. Feed Roller
- 294. Upper Limit Sensor
- 295. Pick-up Roller
- 296. Paper Height Sensor (Near End)
- 297. Paper Height Sensor (Paper Remaining: 25%)
- 298. Paper Height Sensor (Paper Remaining 50%)
- 299. Bottom Tray
- 300. Paper Remaining Sensor (Paper Remaining: 75%)
- 301. Lift Motor
- 302. Lower Limit Sensor
- 303. Tray Drive Belt
- 304. Paper Sensor
- 305. Reverse Roller
- 306. Grip Roller

## 29.2 DETAILS

- ◆ **Feed / Separation**  
FRR method including a non-contact magnetic maintenance-free torque limiter (same the bypass tray of the main machine)
- ◆ **Tray Up / Down**  
A lift motor and a timing belt shift the tray up / down
- ◆ **Size Detection**  
Adjusted with SP mode input, not with the side fence (fixed)
- ◆ **Paper Height Sensor**  
Four photointerrupters and a feeler detect the height of the tray
- ◆ **Paper End Detection**  
A reflective sensor installed in the upper stay detects paper

### 29.2.1 TRAY SHIFT UP / DOWN

The tray motor [G] drives the tray drive belt [A] through a gear and the tray drive pulley. The tray drive belt [A] shifts the tray [B] up / down. ([C]: Near End Sensor, [D][E][F]: Paper Height Sensor 1 ~ 3)

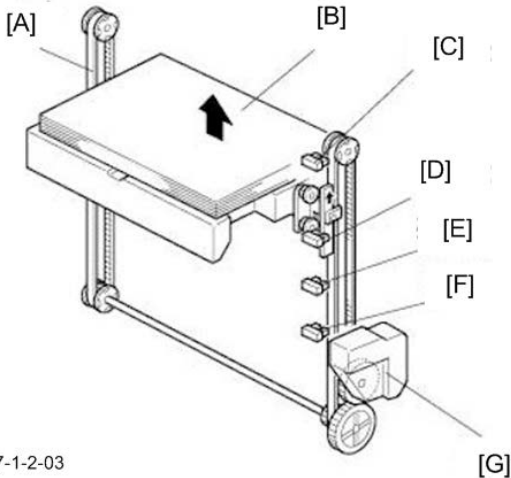

After adding paper, when the upper cover is closed, the pickup solenoid [A] turns ON for the pickup roller [C] to drop down. In this state, if none of the paper height sensors are interrupted, the tray [B] shifts down until a sensor is interrupted. Then the tray shifts up. To check the tray [B] position, the following process is done and then the tray [B] stops: the tray motor drives in reverse until the lift sensor [B] is not interrupted → the tray motor drives forward until the lift sensor [B] is interrupted.

After some sheets are fed, when the top of the stack drops so that the actuator leaves the lift sensor [B], the tray motor drives forward again in order to lift the top of the paper stack to the correct position for feed.

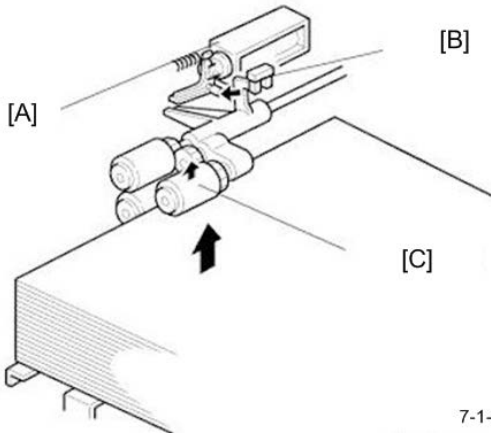

7-1-2-08

When the tray down button [A] is pushed, the tray motor drives in reverse and the tray shifts down until the top of the paper stack reaches the paper sensor [B]. Then the tray motor [C] stops (approximately 500 sheets can be added).

The lower limit sensor [D] detects the lowest point that the tray can shift.

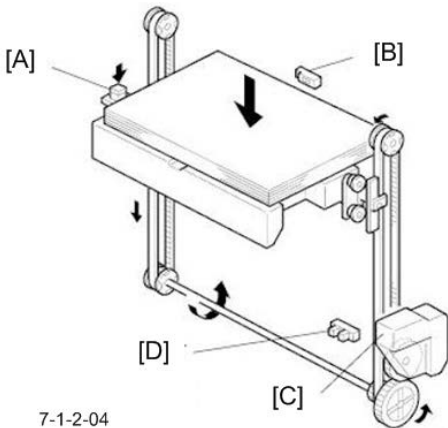

7-1-2-04

◆ **Tray Shift-up Trigger**

- Power switch ON
- Lift sensor ON (Interrupted) while copying
- Closing the upper cover when lift sensor is ON  
⇒Lift Sensor OFF (Not Interrupted) means "shift-up stop".

◆ **Tray Shift-down Trigger**

- Pushing the tray down button
- At paper-end  
⇒Shift-down stops when the stack sensor is OFF.

### **29.2.2 SIZE DETECTION**

By changing the location of the side fence and the rear edge supporting rod, you can switch among A4 LEF / B5 LEF / LT LEF. The size detection is adjusted with [SP5959-003](#).

### **29.2.3 PAPER REMAINING AMOUNT DETECTION**

This detection is done with four photointerrupters, and the operation panel shows the remaining amount.

### **29.2.4 PAPER-END DETECTION**

A reflective photosensor on the upper stay detects the top of the paper stack. If it cannot detect paper, the machine signals paper end.

## 30. LCIT RT4030

### 30.1 OVERVIEW

#### 30.1.1 OVERVIEW LAYOUT

Comment [n 87]: 3/15  
Turned some diagrams J to numbers

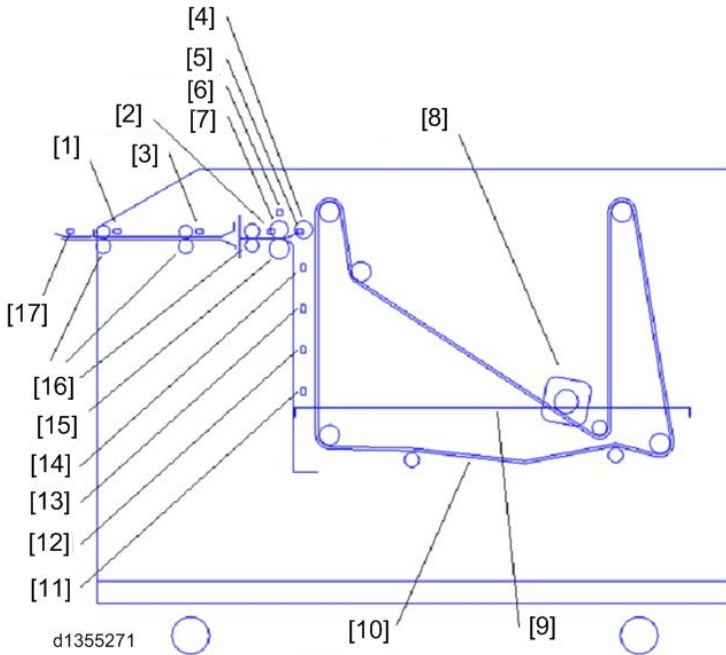

- 307. Exit Sensor
- 308. Feed Sensor
- 309. Transport Sensor
- 310. Pick-up Roller
- 311. Paper End Sensor
- 312. Upper Limit Sensor
- 313. Feed Roller
- 314. Tray Lift Motor
- 315. Tray
- 316. Tray Belt Drive Motor
- 317. Paper Height Sensor 4
- 318. Paper Height Sensor 3
- 319. Paper Height Sensor 2
- 320. Paper Height Sensor 1
- 321. Reverse Roller
- 322. Transport Roller
- 323. LCIT Relay Roller

### 30.1.2 DRIVE LAYOUT

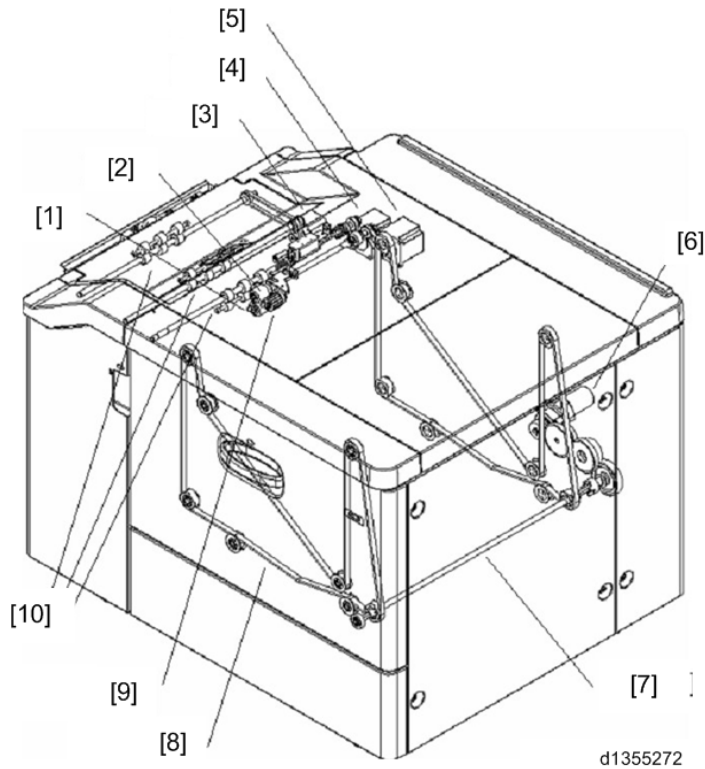

d1355272

- 324. Reverse Roller
- 325. Feed Roller
- 326. Exit Motor
- 327. Transport Motor
- 328. Feed Motor
- 329. Lift Motor
- 330. Tray Lift Shaft
- 331. Tray Drive Belt
- 332. Pick-up Roller
- 333. Transport Roller

### 30.1.3 ELECTRICAL COMPONENTS LAYOUT

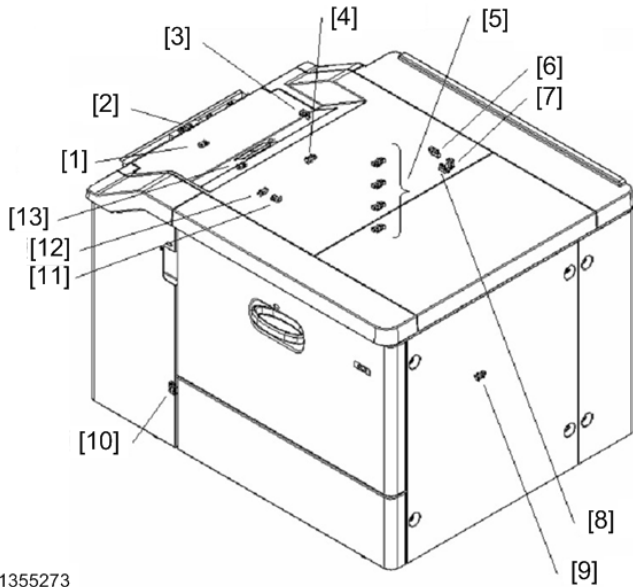

d1355273

- 334. Exit Sensor
- 335. LCIT Relay Sensor
- 336. Left Upper Cover Open/Close Sensor
- 337. Upper Limit Sensor
- 338. Paper Height Sensor (1 ~ 4)
- 339. Paper Size Sensor 3
- 340. Paper Size Sensor 2
- 341. Paper Size Sensor 1
- 342. Paper Length Sensor
- 343. Front Cover Open/Close Sensor
- 344. Paper End Sensor
- 345. Feed Sensor
- 346. Transport Sensor

### 30.1.4 OTHERS LAYOUT

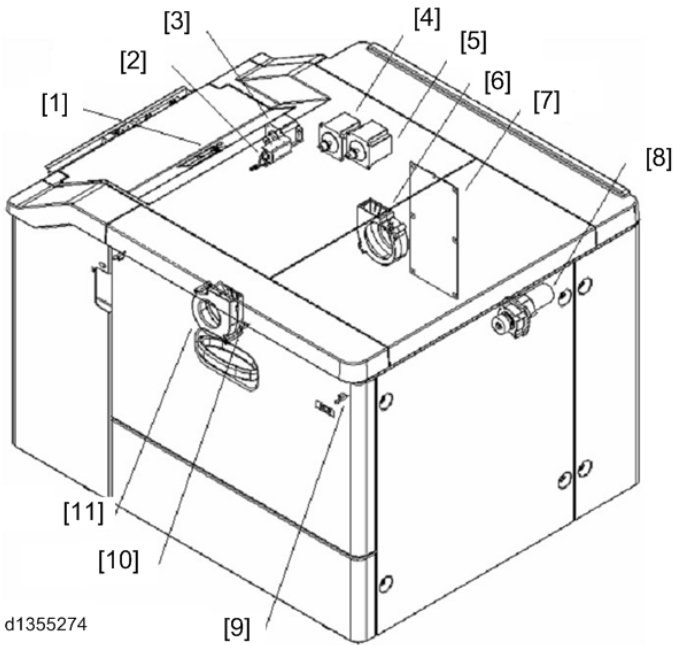

d1355274

- 347. Left Upper Cover LED
- 348. Pick-up Solenoid
- 349. Exit Motor
- 350. Transport Motor
- 351. Feed Motor
- 352. Blower Fan (Rear)
- 353. PCB
- 354. Lift Tray Motor
- 355. LED (suggesting tray lift operation)
- 356. Feed LED
- 357. Blower Fan (Front)

## 30.2 DETAILS

### 30.2.1 FEED / SEPARATION

The feed unit includes a pickup roller, a feed roller, and a reverse roller (FRR feed method). It also includes a  $\phi 20$  grip transport roller.

A magnetic torque limiter is attached to the reverse roller. Reverse pressure is applied in accordance with opening and closing of the tray.

**Comment [ n 88]:** RE:  
 Sorry, I wrote in quite oblique manner.  
 Simply this part means:  
 "This magnetic torque limiter shifts the separation roller up/down responding to the tray open/closed."  
 OK, thanks, but this still seems a bit strange (not the English, but the machine) – I will ask somebody what the machine does

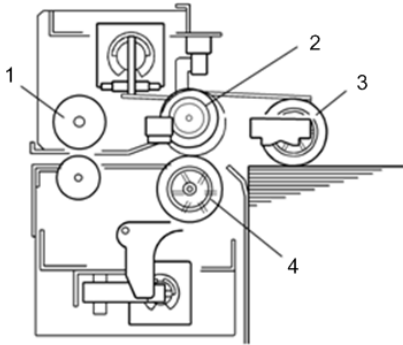

d350d930

- 358. Feed Roller
- 359. Pick-up Roller
- 360. Reverse Roller
- 361. Grip Roller

### 30.2.2 FEED / SEPARATION OPERATION

The grip motor turns on and then the pickup solenoid turns on. The feed motor turns on and the feed roller rotates. At the same time, through a relay gear, the pickup roller rotates to feed the top sheet of the paper stack. The reverse roller contains a torque limiter. The friction between the reverse roller and the feed roller exceeds the limit of the torque limiter, and the reverse roller rotates with the feed roller. When two or more sheets of paper are fed, the torque limiter makes the reverse roller rotate to push the lower sheet of paper back to the tray. When the feed sensor (reflective photosensor) detects paper, the pickup solenoid turns off and the pickup roller lifts away from the paper, to reduce the resistance to paper feed.

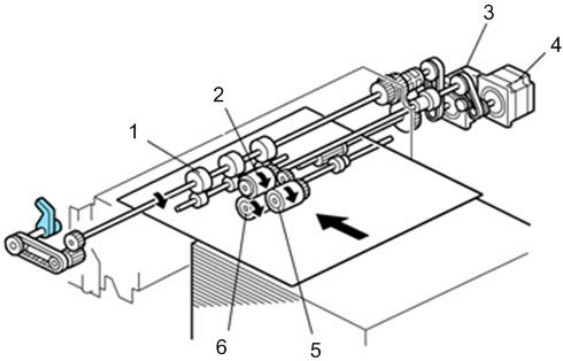

d350d931

- 362. Transport Roller
- 363. Feed Roller
- 364. Transport Motor
- 365. Feed Motor
- 366. Pick-up Roller
- 367. Reverse Roller

### 30.2.3 TRAY SHIFT UP / DOWN

As shown in the picture below, the tray lift motor on the back of the tray drives a belt and pulley in order to lift the tray.

When the tray is pulled out, the tray's coupling with the tray lift motor is released and the tray shifts down under its own weight.

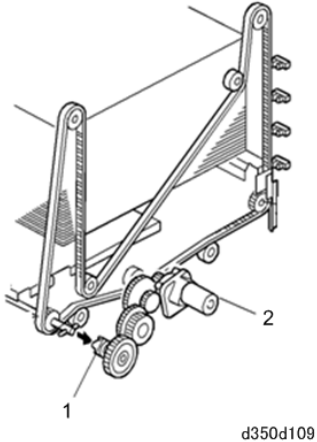

d350d109

- 368. Coupling Gear
- 369. Tray Lift Motor

After paper is added to the tray, the pickup solenoid turns ON and the pickup roller contacts the top sheet of the paper stack. At this time, if the lift sensor detects the actuator, the lift motor turns on in order to lift the bottom plate of the tray. When the tray shifts up, the pickup roller is lifted off the surface of paper. When the actuator exits the lift sensor (sensor turns ON), the lift motor turns off. After that, to enhance the accuracy of the bottom tray lift, the lift motor drives in the reverse direction for 1 s (when reversing, the mechanism acts as a brake), 10ms after the lift motor stops. If the tray is already at the correct height when the pickup roller moves down, this brake operation is done immediately without lift. The top of the paper stack drops during printing, and when the lift sensor becomes "interrupted", the lift motor drives forward again to lift the paper stack.

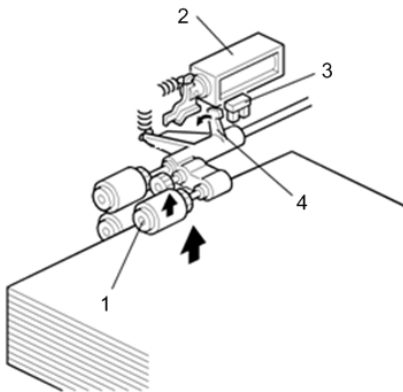

d350d934

- 370. Pick-up Roller
- 371. Pick-up Solenoid
- 372. Lift Sensor

373. Actuator

### 30.2.4 PAPER SIZE DETECTION

The size detection is done with three width sensors and a length sensor.

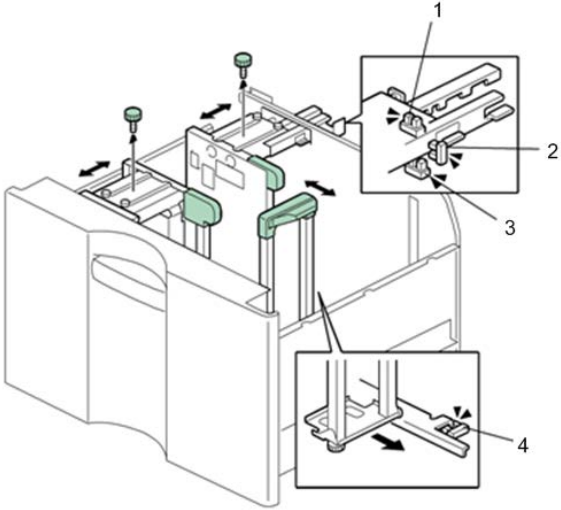

d350d111

- 374. Width Size Sensor (W3)
- 375. Width Size Sensor (W2)
- 376. Width Size Sensor (W1)
- 377. Length Sensor (L1)

The detection pattern is as follows:  
Correlation between Sensor States and Paper Sizes

Size		Width Sensors			Length Sensor
		W1	W2	W3	L1
Paper with Margin	12"x18"	Not Interrupted	Not Interrupted	Not Interrupted	Interrupted
A3 SEF	297 x 420	Not Interrupted	Not Interrupted	Interrupted	Interrupted
A4 LEF	297 x 210	Not Interrupted	Not Interrupted	Interrupted	Not Interrupted
DLT SEF	11"x17"	Not Interrupted	Interrupted	Not Interrupted	Interrupted
LT LEF	11"x8 1/2"	Not Interrupted	Interrupted	Not Interrupted	Not Interrupted
B4 SEF	257x364	Not Interrupted	Interrupted	Interrupted	Interrupted
B5 LEF	257x182	Not Interrupted	Interrupted	Interrupted	Not Interrupted
A4 SEF	210x297	Interrupted	Not Interrupted	Not Interrupted	Interrupted

## Details

LT SEF	8 1/2"x11"	Interrupted	Not Interrupted	Not Interrupted	Interrupted
A5 LEF	210x148	Interrupted	Not Interrupted	Not Interrupted	Not Interrupted
HLT LEF	8 1/2"x5 1/2"	Interrupted	Not Interrupted	Not Interrupted	Not Interrupted
B5 SEF	182x257	Interrupted	Not Interrupted	Interrupted	Interrupted
F SEF	8"x13"	Interrupted	Not Interrupted	Interrupted	Interrupted
A5 SEF	148 x 210	Interrupted	Interrupted	Not Interrupted	Not Interrupted
HLT SEF	5 1/2"x8 1/2"	Interrupted	Interrupted	Interrupted	Not Interrupted

### 30.2.5 PAPER REMAINING AMOUNT DETECTION

This detection is done with four photo-interrupters, and the operation panel shows the remaining amount.

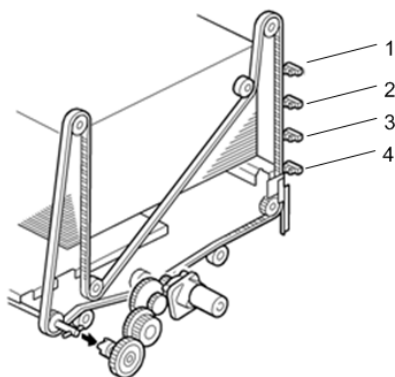

d350d109a

- 378. Paper Height Sensor 1
- 379. Paper Height Sensor 2
- 380. Paper Height Sensor 3
- 381. Paper Height Sensor 4

#### Correlation of Sensor and Paper Amount Remaining

Remain Level	Sensor interrupted / not interrupted			
	Remain Sensor 1	Remain Sensor 2	Remain Sensor 3	Remain Sensor 4
100%	Not Interrupted	Not Interrupted	Not Interrupted	Not Interrupted
75%	Not Interrupted	Not Interrupted	Not Interrupted	Interrupted
50%	Not Interrupted	Not Interrupted	Interrupted	—
25%	—	Interrupted	—	—

Near End	Interrupted	Not Interrupted	—	—

### 30.2.6 PAPER END DETECTION

A reflective photo-sensor on the upper stay detects the surface of the paper. If there is no paper, the sensor detects paper end. When paper end is detected, the lift motor drives in reverse to move the tray down.

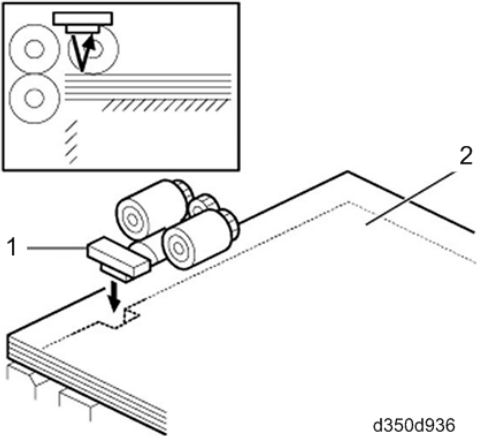

d350d936

- 382. Paper End Sensor
- 383. Paper

#### ◆ Air-Assist Separation

The two air assisting fans use air to separate the top sheet from the rest. This prevents double feed. This mechanism applies only to thick paper.

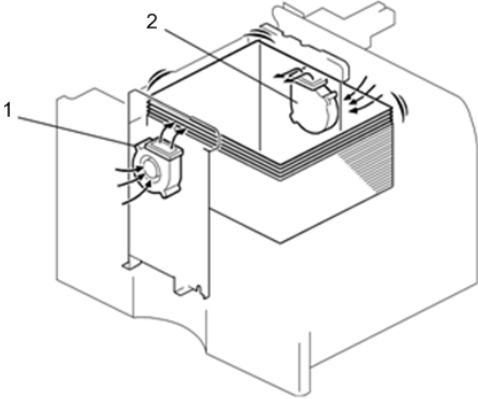

d350d935a

- 384. Blower Fan (Front)
- 385. Blower Fan (Rear)

### 30.2.7 PAPER EXIT

The LCIT exit motor drives the exit rollers through a timing belt in order to output paper. At the output, the entrance roller in the main machine sends the paper into the machine.

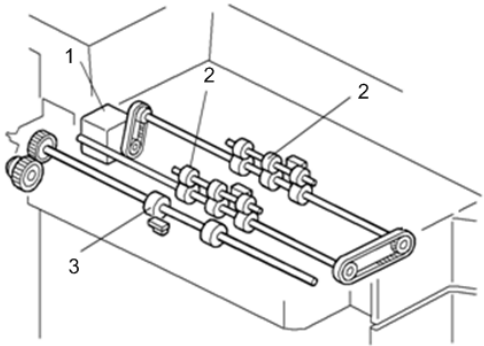

d350d935

- 386. Exit Motor
- 387. Exit Roller
- 388. Entrance Roller (main machine side)

# 31. 2,000-SHEET BOOKLET FINISHER (SR4100) 3,000-SHEET FINISHER (SR4090)

## 31.1 OVERVIEW

### 31.1.1 GENERAL SPECIFICATIONS

**Comment [ n 89]:** 1/18  
With new diagrams, I re-wrote almost all the parts.  
1/28/13  
Revised some parts. (Some pics are revised by Nagao-san.)

		2,000-Sheet Booklet Finisher (SR4100) 3,000-Sheet Non Booklet Finisher (SR4090)	Remarks
Supported Thickness	Proof Tray	52 g / m <sup>2</sup> ~ 220 g / m <sup>2</sup>	Improved the press power of the transport roller
	Shift Tray	52 g / m <sup>2</sup> ~ 300 g / m <sup>2</sup>	Improved the press power of the transport roller
	Corner Staple	52 g / m <sup>2</sup> ~ 105 g / m <sup>2</sup> (Cover sheet 256g / m <sup>2</sup> can be included [max 2 sheets])	Changed the in-body stack method to the half tray method.
	Booklet Staple	64 g / m <sup>2</sup> ~ 105g / m <sup>2</sup>	
	Punch	52 g / m <sup>2</sup> ~ 256g / m <sup>2</sup>	Changed the punch edge shape and improved the motor power
Supported Paper Size	Proof Tray	A3T ~ A5, B6T, A6T, 12"X18", HLT ~ DLTT, SRA3, 13"X19.2"	Sized up the space between the side fence
	Shift Tray	A3T ~ A5, B6T, A6T, 12"X18", HLT ~ DLTT, SRA3, 13"X19.2"	
	Corner Staple	A3T ~ B5, 12"X18", DLTT ~ LT	
	Booklet Staple	A3T, B4T, A4T, B5T, 12"X18", DLTT, LG, LTT, SRA3, 13"X18"	
	Punch	A3 ~ A5, DLT ~ HLT	
Corner Staple Capacity		65 Sheets (A4, LT or less) (80g / m <sup>2</sup> )	Changed the stapler to EH-600
		65 Sheets (B4, LG or less) (80g / m <sup>2</sup> )	
Booklet Staple Capacity		20 Sheets (80g / m <sup>2</sup> )	Changed the stapler to EH-178
Weight		52kg or less (Booklet / Punch available)	Shaped the unit to lighten

### 31.1.2 LAYOUT

◆ General Layout

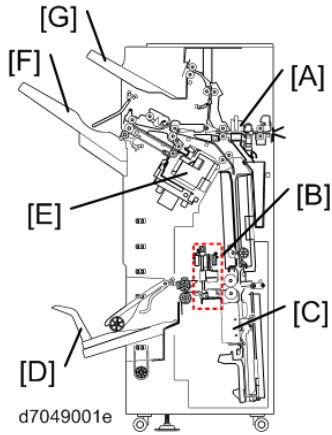

No.	Name	No.	Name
A	Punch Unit	E	Corner Stapler
B	Saddle Shaping Unit	F	Upper Tray
C	Booklet Stapler	G	Proof Tray
D	Lower Tray		

◆ Transport Layout

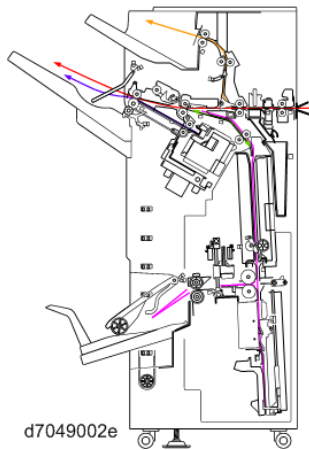

Red	Straight Through Path
Orange	Proof Path
Green	Pre-stack Path
Purple	Corner Staple Path
Pink	Booklet Staple Path

◆ Proof Transport Layout (Drive)

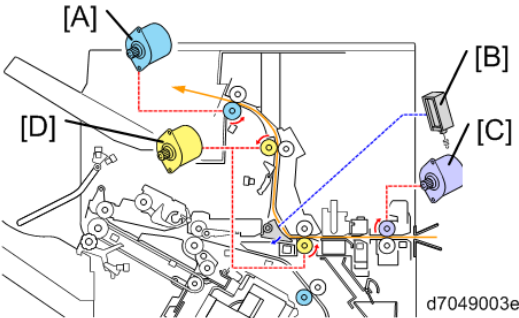

No.	Name	No.	Name
A	Proof Exit Motor	C	Entrance Transport Motor
B	Junction Gate Solenoid	D	Horizontal Transport Motor

◆ Proof Transport Layout (Sensor)

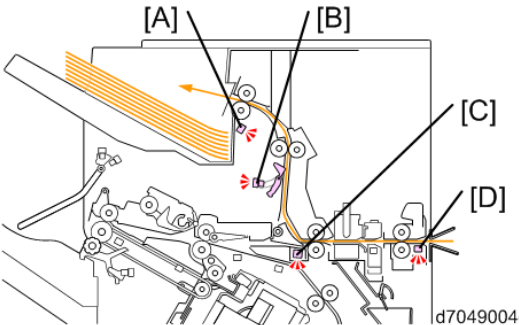

No.	Name	No.	Name
A	Proof Tray Full Sensor	C	Horizontal Transport Sensor
B	Proof Exit Sensor	D	Entrance Sensor

◆ Shift Transport Layout (Drive)

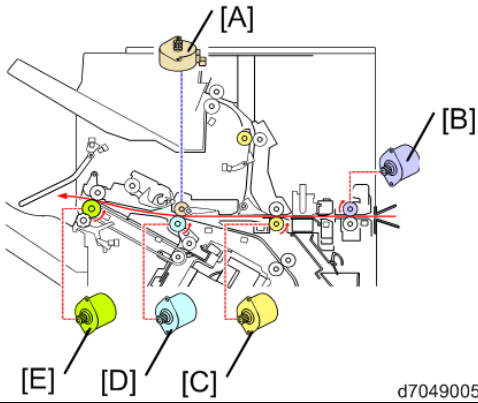

d7049005e

No.	Name	No.	Name
A	Shift Roller Motor (shift only)	D	Relay Transport Motor
B	Entrance Transport Motor	E	Upper Tray Exit Motor
C	Horizontal Transport Motor		

## 31.2 DETAILS

### 31.2.1 SHIFT OPERATION (SHIFT TRANSPORT)

To output paper, the shift roller motor [A] moves the shift roller [B] side-to-side while a transport operation (the shift roller is driven). The shift roller HP sensor [C] is used to control this mechanism.

**Comment [n 90]:** 1/25 revised

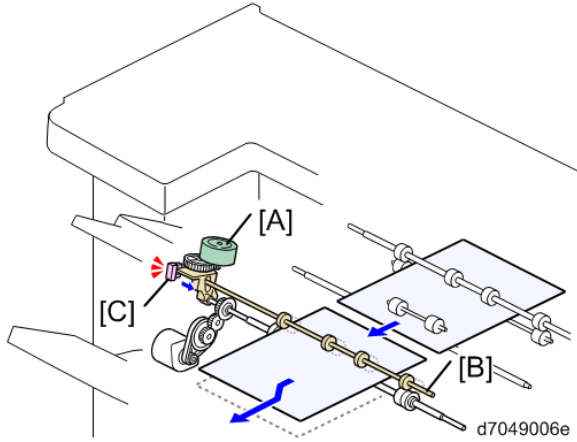

### 31.2.2 PRE-STACK OPERATION (IN CORNER STAPLING)

- **Pre-stack Capacity:** 1 sheet
- **Pre-stack Size:** A4 SEF/LEF, B5 SEF/LEF, LT SEF/LEF

There are four steps as follows:

389. The upper tray exit guide plate [A] shifts up (open). Paper comes through the entrance transport path and reaches the relay transport path.

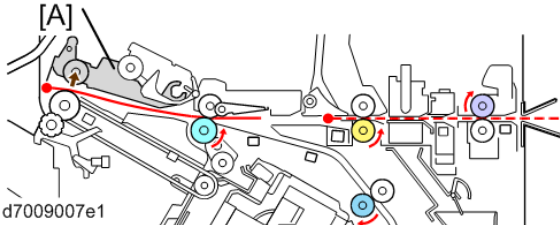

390. After paper passes by the pre-stack junction gate [A], the pre-stack junction gate [A] shifts down (closed) and the relay transport roller [C] rotates in reverse. The pre-stack roller [B] rotates to transport paper to the pre-stack position.

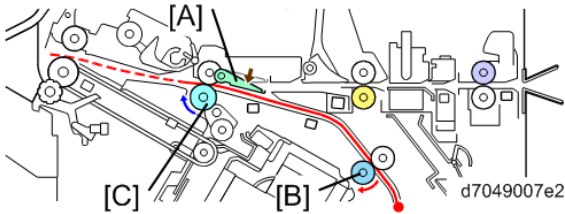

391. The rotation of the relay transport roller [C] and the pre-stack roller [B] stops, and the pre-stack junction gate [A] shifts up (open). The shift roller [D] also shifts up to release the pressure between itself [D] and the relay transport roller [C].

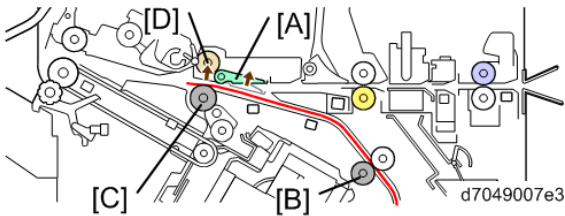

392. The following paper comes through the entrance and reaches the relay transport path. After that, the shift roller [A] that stays in the upper position drops in order to press pre-stacked paper and the following paper. Then with pre-stacked paper, the following paper goes to the next process (corner staple part).

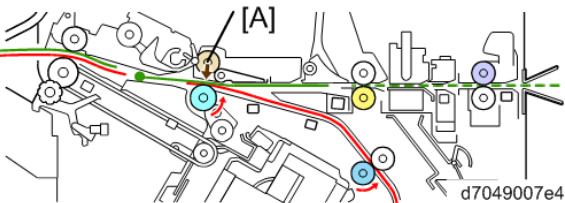

### 31.2.3 PRE-STACK OPERATION (IN BOOKLET STAPLING)

- **Pre-stack Capacity:** 2 sheet
- **Pre-stack Size:** All Sizes

There are five steps as follows:

393. The upper tray exit guide plate [A] shifts up (open). Paper comes through the entrance transport and reaches the relay transport path.

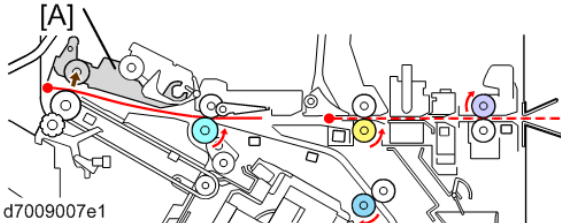

394. The pre-stack junction gate [A] drops (closed) and the relay transport roller [C] rotates in reverse. The pre-stack roller [B] rotates to transport paper to the pre-stack position.

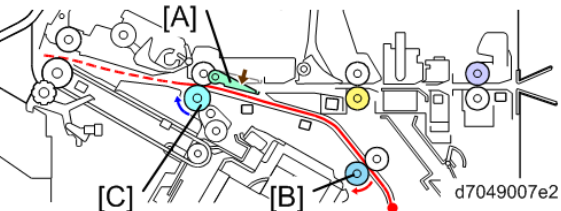

395. The rotation of the relay transport roller [C] and the pre-stack roller [B] stops, and the pre-stack junction gate [A] shifts up (open). The shift roller [D] shifts up to release the pressure between itself [D] and the relay transport roller [C].

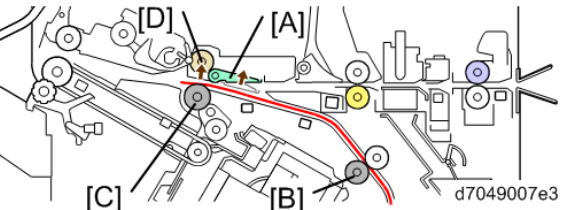

396. The following paper comes through the entrance and reaches the relay transport path. After that the shift roller [A] that stays in the upper position drops to press pre-stacked paper and the following paper. With pre-stacked paper, the following paper goes toward the rest of the path (not passes through completely).

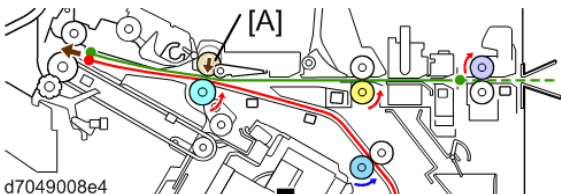

397. The pre-stack junction gate [B] drops (closed) again and the relay transport roller [A] rotates in reverse and the pre-stack roller [C] rotates to send doubled paper (pre-stacked paper and the following paper) to the booklet staple path.

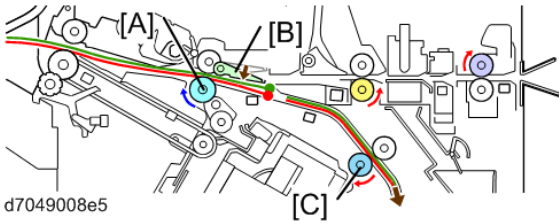

### 31.2.4 UPPER TRAY SHIFT DRIVE / LIMIT SENSOR / FULL SENSOR

◆ **Upper Tray Shift Up/down**

The upper tray lift motor [A] moves the upper tray up/down.

◆ **Upper-position Detection**

With the actuator, the limit sensor [B] detects the upper position of the tray (without output paper). To prevent too much moving upward, the forced stop switch (interlock SW) [C] is installed. When the upper tray moves up to the upper position but doesn't stop, the forced stop switch is pushed and the tray shift motor [A] stops forcibly.

◆ **Upper Tray Full Detection**

Five full sensors [D] are installed on the rear side of the machine. The state of those sensors [D] that are interrupted determines the full state.

Each sensor means as follows: 500 / 1000 / 1500 / 2000 / 3000 sheets (from upper to lower)

\*In D704: 500 / 1000 / 2000 sheets sensors are used.

\*In D703: 500 / 1500 / 3000 sheets sensors are used.

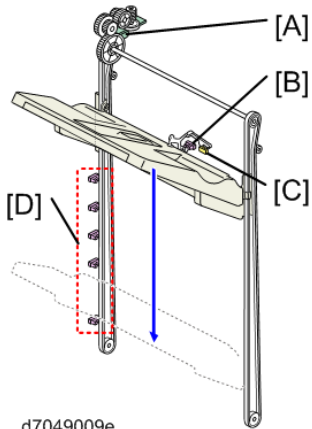

### 31.2.5 PULL-IN ROLLER / PAPER STACK HOLDER

◆ Components

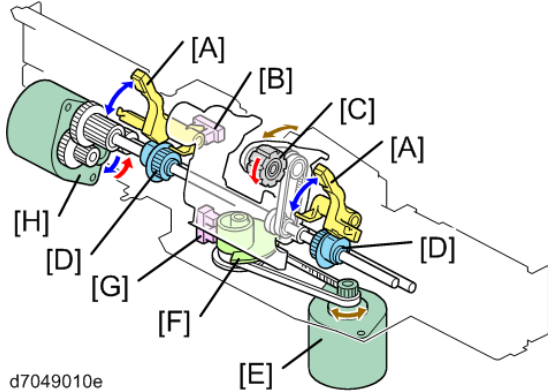

No.	Name	No.	Name
A	Paper Stacking Holder	E	Stacking Sponge Roller Fluctuation Motor
B	Holder HP Sensor	F	Stacking Sponge Roller Cam
C	Stacking Sponge Roller	G	Stacking Sponge Roller HP Sensor
D	Paper Stacking Holder Cam	H	Paper Stacking Holder Motor

◆ Operation

There are five steps in the operation:

- 398. When a job starts, the paper stacking holder motor rotates the paper stacking holder cam [B] to shift the paper stacking holder [A] down.
- 399. The stacking sponge roller fluctuation motor rotates the stacking sponge roller cam [D] to move the stacking sponge roller [E] down. The paper stacking holder motor rotates the paper stacking holder cam [B] to lift the paper stacking holder [A] up to its HP (until the paper stacking holder interrupts the paper stacking holder HP sensor [C]).

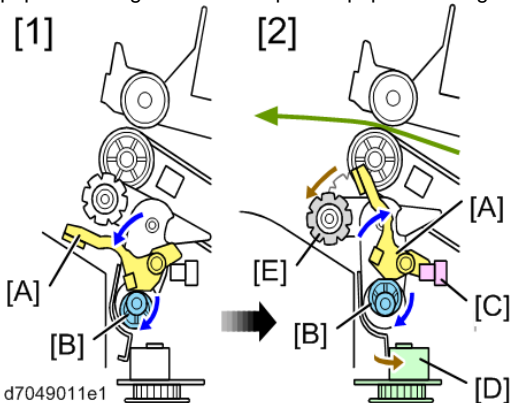

- 400. The paper stacking holder motor drives in reverse to let the stacking sponge roller [A] pull output paper in.
- 401. The paper stacking holder motor rotates the paper stacking holder cam [C] to drop the

paper stacking holder [B] down (until a job end, the machine repeats step3 and step4).

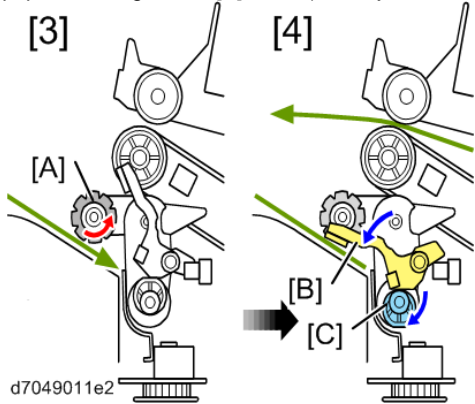

d7049011e2

402. After a job end, the stacking sponge fluctuation motor rotates the stacking sponge roller cam [D] to lift the stacking sponge roller [A] up to its HP position. At the same time, the paper stacking holder motor rotates the holder cam [E] to lift the paper stacking holder [B] up to its HP (until the paper stacking holder HP sensor [C] detects the end of the paper stacking holder [B]).

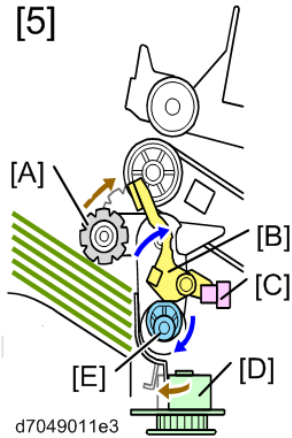

d7049011e3

### 31.2.6 CORNER STAPLING

◆ Components

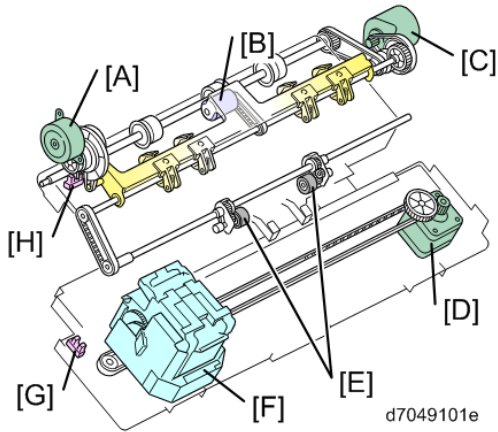

No.	Name	No.	Name
A	Positioning Roller Lift Motor	E	Drag Roller
B	Positioning Roller	F	Stapler
C	Exit Motor	G	Stapler HP Sensor
D	Stapler Movement Motor	H	Positioning Roller HP Sensor

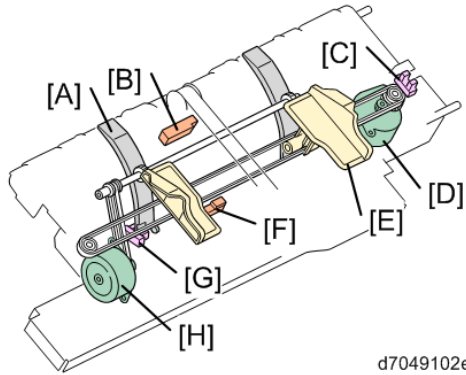

No.	Name	No.	Name
A	Edge Guide	E	Jogger Fence
B	Upper Tray Exit Sensor	F	Staple Tray Paper Sensor
C	Jogger HP Sensor	G	Edge Guide HP Sensor
D	Jogger Motor	H	Edge Guide Motor

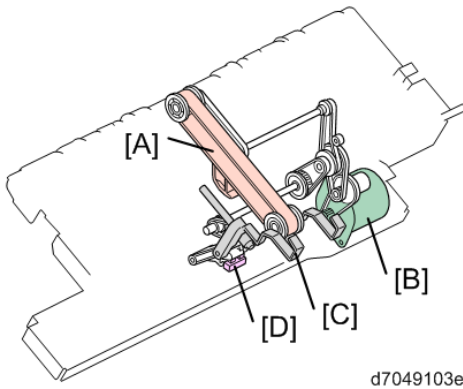

d7049103e

No.	Name	No.	Name
A	Stack Feed-out Belt (with stack feed-out pawl)	C	Bottom Pawl
B	Stack Feed-out Motor	D	Stack Feed-out Pawl HP

◆ **Edge Guide**

This machine applies a corner-staple to a paper stack whose body lingers out of the exit. At this time, to prevent a paper stack from dropping down to the upper tray, the edge guide [D] comes out of the unit.

The edge guide operates as the following way:

403. When a job starts, the upper tray guide plate [A] shifts up.

404. The edge guide motor [B] drives to push the edge guide [D] out. The edge guide retreats to the machine when the last paper of a job is output (the edge guide HP sensor [C] detects the edge guide).

**Comment [ n 91]:** 1/25  
Added some descriptions

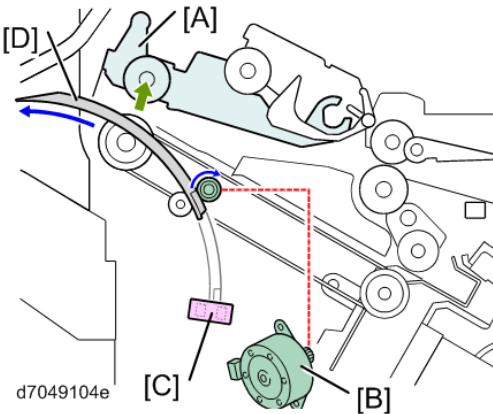

d7049104e

◆ **Stapler Move**

The staple movement motor [A] moves the stapler [C] along the guide rod [B]. After a job finishes, the stapler [C] returns to its HP (the stapler HP sensor [D] detects the base of the stapler).

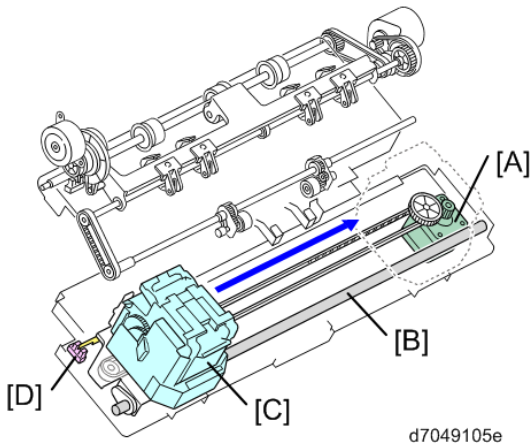

d7049105e

◆ **Positioning Roller / Drag Roller**

The positioning roller and drag roller operate as the following way:

- 405. The positioning roller shift motor [A] moves the positioning roller [D] down in every job.
- 406. The positioning roller motor [B] rotates the positioning roller [D] to transport paper to the staple tray.
- 407. The positioning roller motor [B] also rotates the drag roller [C]. The drag roller [C] is a sponge roller that pushes paper against the bottom pawl, in order to hold paper in the staple position.

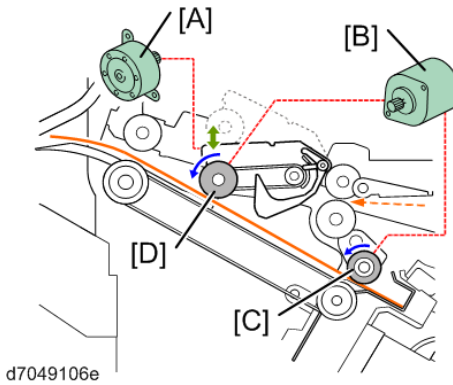

d7049106e

◆ **Jogger**

The jogger motor [A] moves the jogger fences [C] to their ready position. After that, in every job, jogger operation is done, in which paper stack is aligned. After a job end, the jogger fences return to their HP (the jogger fence HP sensor [B] detects the jogger fence).

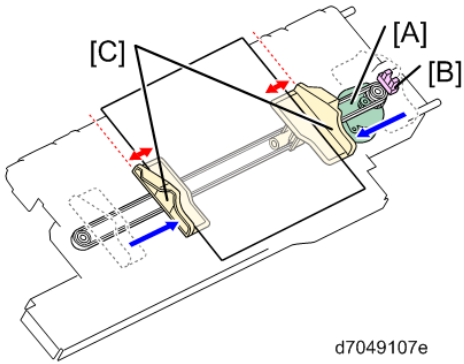

d7049107e

◆ **Stapling**

The staple hammer motor [B] lets the staple hammer [A] down in order to staple a paper stack. The stapling points vary as follows:

- **When oblique stapling:** [1]
- **When horizontally stapling:** [2]
- **When horizontally stapling (2 points stapling):** [3]

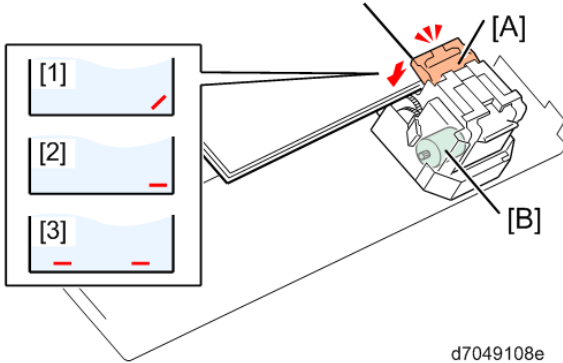

d7049108e

◆ **Feeding-out**

The bottom pawl [B] moves paper up to the proper position to output. Then the stack feed-out pawl [A] that attaches on the stack feed-out belt [C] pushes paper out. The stack feed-out motor [D] moves not only the stack feed-out pawl [A] but also the bottom pawl [B]. After an output, both of the pawls [A] [B] return to their HP.

d7049109e

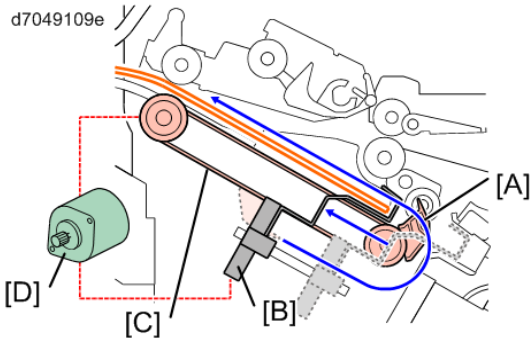

### 31.2.7 SADDLE-SHAPE STAPLING (BOOKLET STAPLING)

◆ **What's Saddle-shape stapling?**

Comparing to normal stapled booklet [A], this machine's stapled (saddle-shape stapled) booklet [B] can reduce bulge of a booklet.

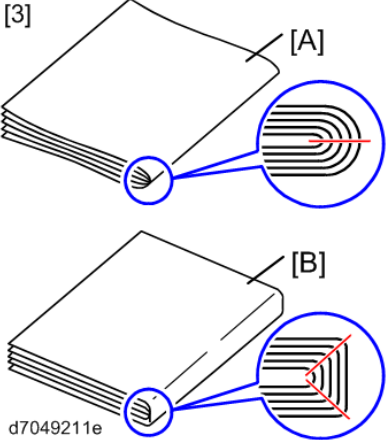

d7049211e

◆ **Saddle-shape Applying-logic**

In this machine, saddle-shape is applied as following way:

- 408. When a roller presses at a point of bent paper, crease is applied on paper.
- 409. When rollers press from the upper and the lower, crease is applied to both upper and lower. Then rollers shift side-to-side as shown. Finally, a paper stack is saddle shaped.

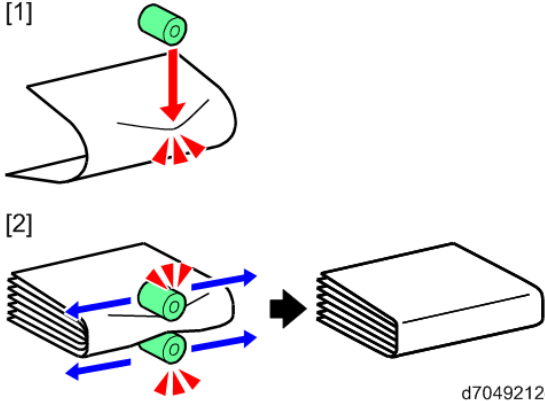

d7049212e

◆ Components

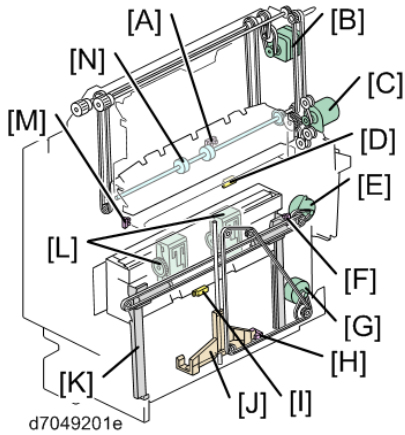

d7049201e

No.	Name	No.	Name
A	Stack junction Gate HP Sensor	H	Bottom Fence HP Sensor
B	Shift Roller Lift Motor	I	Booklet Lower Transport Path Paper Sensor
C	Shift Roller Drive Motor	J	Bottom Fence
D	Booklet Upper Transport Path Paper Sensor	K	Jogger Fence
E	Jogger Fence Motor	L	Booklet Stapler
F	Jogger Fence HP Sensor	M	Guide Open/Closed Sensor
G	Bottom Fence Motor	N	Shift Roller

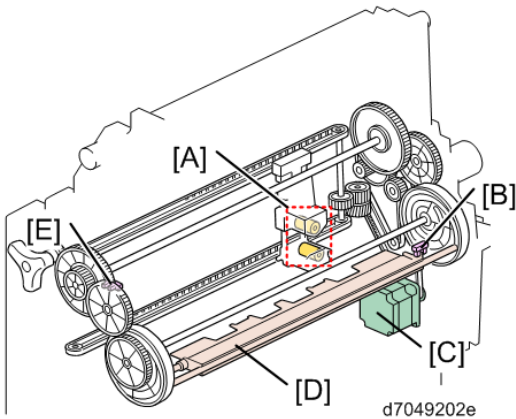

d7049202e

No.	Name	No.	Name
A	Side-to-side Shift Fold Roller	D	Fold Plate
B	Fold Plate HP Sensor	E	Fold Plate Cam Sensor

**Comment [ n 92]:** 1/17  
 In Japanese this is called “紙折りローラ”. Maybe this is a new part. I think we need to give a new name to it. (Here I named provisionally.)

No.	Name	No.	Name
C	Fold Plate Motor		

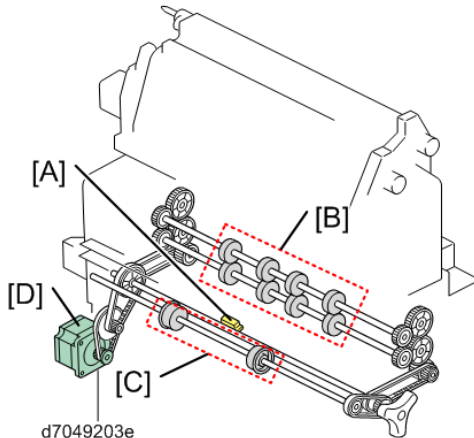

d7049203e

No.	Name	No.	Name
A	Fold Unit Exit Sensor	C	Fold Unit Exit Roller
B	Fold Roller	D	Fold Roller Motor

◆ **Booklet Staple Transport**

When paper begins to go through the booklet staple path, the shift roller unit [A] moves up to its operating position in order to be ready to transport paper. The shift roller lift motor moves the shift roller unit [A].

The shift roller drive motor rotates the shift roller [B] to transport paper to the bottom.

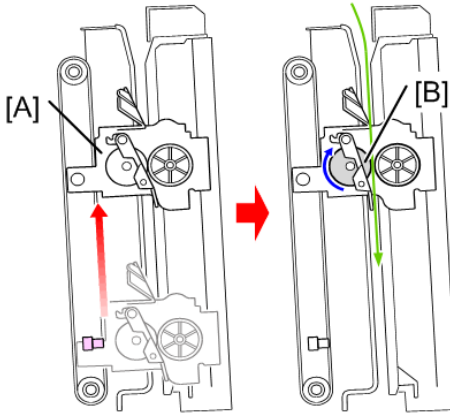

d7049204e

After the transportation has finished, the shift roller unit [B] moves up away from the paper face. While the shift roller unit moves up, the shift roller [A] rotates to feed paper out to the bottom. Then the shift roller unit drops to bump the stack junction gate [C] onto the edge of a paper stack. With this operation, a paper stack is aligned.

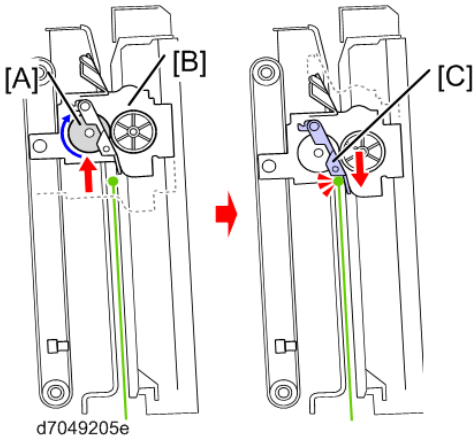

◆ **Jogger**

The jogger fence motor [A] drives to apply jogger operation in every job. When a job starts, the jogger fences [B] move to a ready position that is varied depending on the paper type. After that, jogger operation is applied in every job.

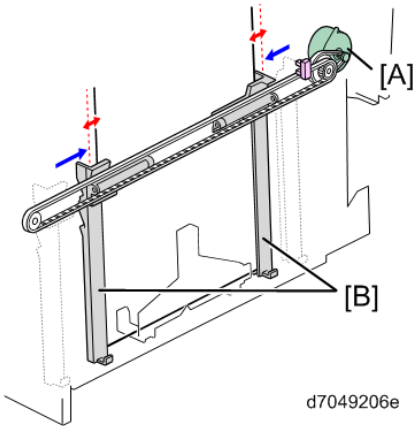

◆ **Bottom Fence Operation / Staple**

Paper that is pushed with the stack junction gate bumps onto the bottom fence [B] in order to align a paper stack. Then the booklet staplers [C] staple at the middle points of a paper stack. After that, the bottom fence motor [A] moves the bottom fence [B] up to the position where a paper stack is folded with the fold plate.

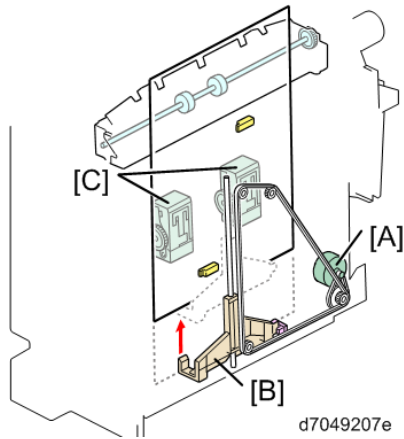

◆ **Fold Operation**

The fold plate [C] fold a paper stack that is lifted up to the fold position with the bottom fence. The fold plate motor moves not only the fold plate [C] but also the side-to-side shift fold roller unit [E] because it needs to engage the operation of the fold plate [C] and the side-to-side shift fold roller unit [E].

**Comment [ n 93]:** 1/28  
Fully revised

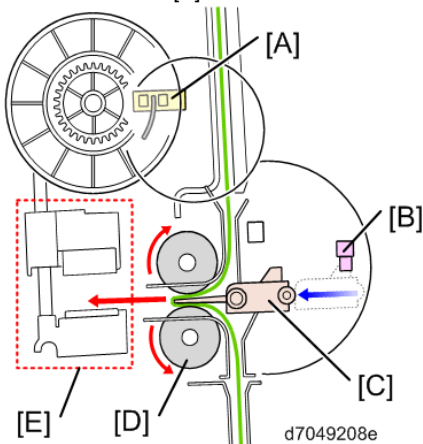

When the operation starts the fold plate [B] pushes a paper stack into between the rollers, the side-to-side shift fold roller unit [A] slides on the upper path [D]. Both operations are done by the fold plate motor. When the fold plate [B] pushes a paper stack fully, the side-to-side shift fold roller unit [A] comes down to the lower path (position [C]) and presses the center of a paper stack that is pushed by the fold plate [B].

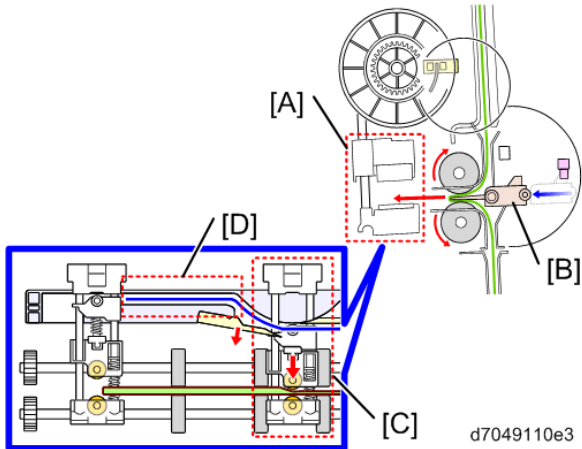

By the cam of the fold plate, the fold plate [C] keeps sticking a paper stack while the side-to-side shift fold roller unit [A] presses the half of a paper stack (for details about the press operation, see "Saddle Shaping Operation" described later). When the HP sensor [B] turns on 2 times (the cam of the side-to-side shift fold roller unit rotates 2 times), the operation of side-to-side fold is half done (the side-to-side shift fold roller unit is in the position [D]) and then the fold plate motor begins to drive in reverse.

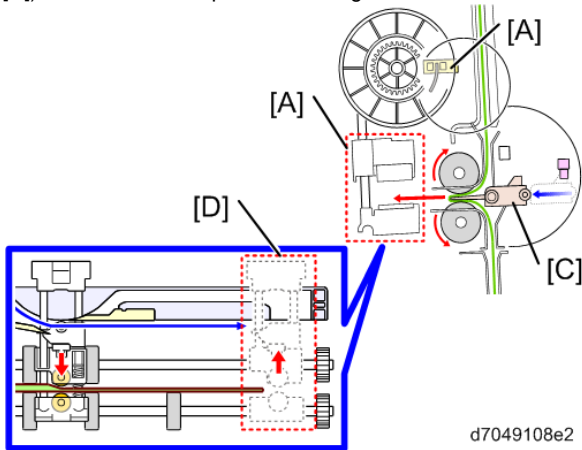

The side-to-side shift fold roller unit slides back on the upper path to the lower path. Then the rest of side-to-side fold is done while the fold plate returns to its HP where the fold plate HP sensor [B] detects the fold plate.

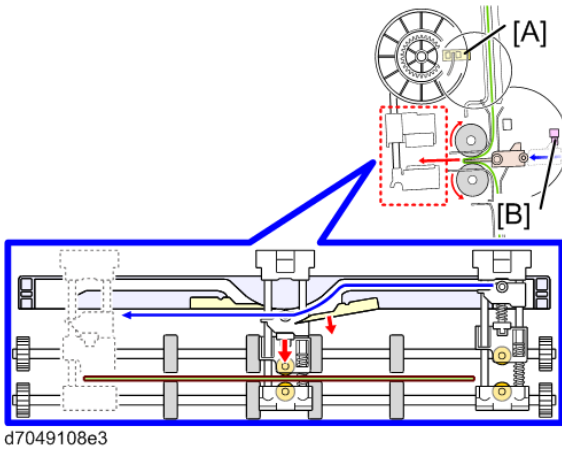

d7049108e3

◆ Saddle Shape Operation Related Components

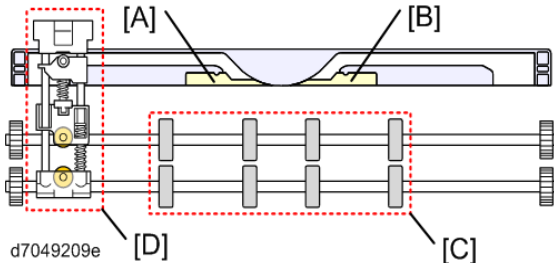

d7049209e

No.	Name	No.	Name
A	Junction Plate 1	C	Fold Roller
B	Junction Plate 2	D	Side-to-side Shift Fold Roller Unit

**Comment [ n 94]:** 1/28/13  
The image diagram is revised by Nagao-san.

**Comment [ n 95]:** 1/17  
In Japanese this is called “紙折りローラ”. Maybe this is a new part. I think we need to give a new name to it. (Here I named provisionally.)

◆ Saddle Shaping Operation

There are five steps in saddle shaping operation as shown below:

- 410. While sliding from the upper path toward the lower path, the side-to-side shift fold roller unit [A] pushes the junction plate 1 [B] out and moves to the center of a paper stack.
- 411. As the side-to-side shift fold roller unit comes to the lower path ([C] position), the upper roller of the side-to-side shift fold roller unit is pushed down. By the pressure of the spring, the side-to-side shift fold roller unit [C]: can apply pressure to a paper stack and make crease on it.
- 412. Applying pressure to a paper stack, the side-to-side shift fold roller unit [C] moves to the front side of the machine (right side in the diagram below).
- 413. At the position [D], the upper roller of the side-to-side shift fold roller unit pops up from the lower path to the upper path.

**Comment [ n 96]:** 1/28/13  
The pics are revised by Nagao-san. So I corrected some texts. (in pink)

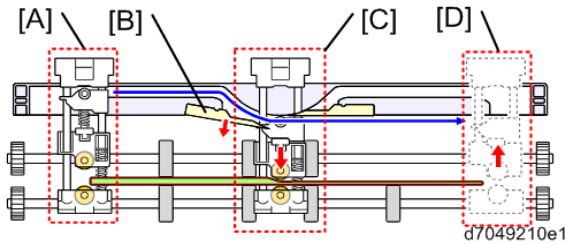

414. The fold plate motor drives in reverse in order to move the side-to-side shift fold roller unit [C] to the rear side (left side in the diagram below) without the pressure to a paper stack. Then the side-to-side shift fold roller unit [C] pushes the junction gate 2 [B] out and comes down to the lower path again.
415. The side-to-side shift fold roller unit [C] returns to the HP [A] with applying the pressure on the other side of a paper stack. In the HP [A], the upper roller of the side-to-side shift fold roller unit pops up from the lower path to the upper path.

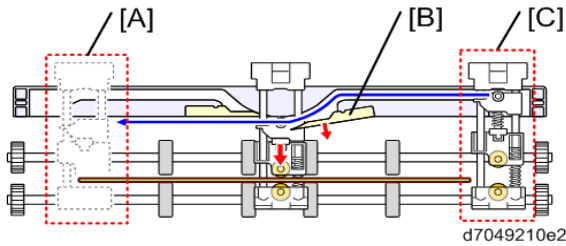

## 32. FINISHER SR 4110

### 32.1 OVERVIEW

#### 32.1.1 GENERAL SPECIFICATIONS

Item	Specification	Remarks	
Type	Console		
Shift Tray Unit			
Capacity	Non-folded Paper	3000 sheets: A4 LEF, B5 LEF, LT LEF	80 g /m <sup>2</sup>
		1500 sheets: A3, A4 SEF, B4, B5 SEF, DL SEF, LG, LT SEF	
		1000 sheets : 12"x18", 13"x19"	
		500 sheets : A5 LEF, HLT LEF	
	100 sheets : A5 SEF, HLT SEF		
	Z-fold Paper	30 sheets	
Size Capacity	A3 ~ A5, DLT ~ HLT	*Tab paper available	
Thickness Capacity	52~216 g /m <sup>2</sup>		
Proof Tray Unit			
Capacity	Non-fold Paper	500 sheets: smaller than A4, LT	
		250 sheets: larger than B4, LG	
	Z-fold Paper	30 sheets	
Size Capacity	A3 ~ A5, DLT ~ HLT, 12"x18", 13"x19"		
Thickness Capacity	52~216 g /m <sup>2</sup>		
Staple Tray Unit			
Capacity	Non-folded Paper	2~100 sheets : A4 SEF, A4 LEF, B5 SEF, B5 LEF, LT SEF, LT LEF	80 g /m <sup>2</sup>
		2~50 sheets: All size except the indicated size above	
	Z-fold Paper	10 sheets	
Stitch Available Size	A3 ~ B5, DLT ~ LT		
Stitch Available Thickness	64~80 g /m <sup>2</sup>		
Stitch Area	Rear, Rear Opposite Corner,		

## Overview

		Front, 2 areas	
Size		800 (W) x 730 (D) x 980 (H) mm	
Weight		75kg or less	
Energy Consumption		100W (Supplied from the main machine)	
Punch Unit			
Equipment Method		Option	
Punch Hole Location		2-hole Punch	
Punch Available Mode		Shift, Proof, Stable Mode	*All Modes
Punch Available Size	2-hole Punch Unit	Short Edge Feed : A3~A5, DLT~HLT	
		Long Edge Feed : A4~A5, LT, HLT	
Punch Available Thickness		52 g / m <sup>2</sup> ~ 163 g / m <sup>2</sup>	45 ~ 135kg

### 32.1.2 SUPPORTED PAPER

Type	Size	Proof	Shift	Staple	2-hole Punch Unit	Punch	
						2-hole / 3-hole Unit	
						2-hole	3-hole
Type 6000	A3	○	○	○	○	○	○
	A4 Short Edge Feed (SE)	○	○	○	○	○	×
	A4 Long Edge Feed (LE)	○	○	○	○	○	○
	A5 SE	○	○	×	○	○	×
	A5 LE	○	○	×	○	○	×
	B4	○	○	○	○	○	○
	B5 SE	○	○	○	○	○	×
	B5 LE	○	○	○	○	○	○
	LT SE	○	○	○	○	○	×
	LT LE	○	○	○	○	○	○
Type 6200	A3	○	○	○	○	○	○
	A4 SE	○	○	○	○	○	×
	A4 LE	○	○	○	○	○	○
	A5 SE	○	○	×	○	○	×

	A5 LE	o	o	x	o	o	x
	B4	o	o	o	o	o	o
	B5 SE	o	o	o	o	o	x
	B5 LE	o	o	o	o	o	o
	LG	o	o	o	o	o	x
	LTT	o	o	o	o	o	x
	LTY	o	o	o	o	o	o
NBS My Paper / Medium Paper (White lily) NBS55K/70K/90K/110K/135K CP80/CB80/CY80 Recycled Paper (NBS My Recycled / Recyclable S.A)	A3	o	o	o	o	o	o
	A4 SE	o	o	o	o	o	x
	A4 LE	o	o	o	o	o	o
	B4	o	o	o	o	o	o
	B5 SE	o	o	o	o	o	x
	B5 LE	o	o	o	o	o	o
NBS180K NBS180K	A3	o	o	o	x	x	x
	A4	o	o	o	x	x	x
	B4	o	o	o	x	x	x
	B5	o	o	o	x	x	x
Type TA/TC	A3	o	x	x	x	x	x
	A4	o	x	x	x	x	x
	B4	o	x	x	x	x	x
	B5	o	x	x	x	x	x
Released Paper (Type SA), Letter Paper	A4 LE	LEF only	x	x	x	x	x
OHP ST	A4	o	x	x	x	x	x

## 32.1.3 ヒューズ一覧表 FUSE LIST

Fuse Name	Output Connector	Capacity	Voltage	Parts No.	Affected Part	Remarks	Removability	
FU100					M1: Shift Paper Output M			
					M2: Tray Upper/Lower M			
					M3: Paper Exit Open/Close M			
		CN120			M4: Staple Paper Exit M			
		CN120			M4: Staple Paper Exit M			
		CN113			M5: Proof Paper Exit M			
		CN121			M5: Proof Paper Exit M			
		CN120			M5: Proof Paper Exit M			
		CN122			M6: Shift M			
		CN123			M7: Proof Switch M			
		CN123			M7: Proof Switch M			
		CN124			M8 Staple Switch M			
		CN146			M8 Staple Switch M			
		CN134			M9: Press Tuck Switch M			
		CN125			M9: Press Tuck Switch M			
		CN128			M9: Press Tuck Switch M			
		CN126			M10: Press Tuck	Full Load		
		CN126			M10: Press Tuck			
		CN127	5A	250V	1107	M11: Press	Punch: Punch Board	Yes
		CN127			1006	M11: Press	Shift Jogger part M:	
		CN128				M11: Press	Shift Jogger Board	
		CN129				Tuck Paw Release M		
		CN129				Tuck Paw Release M		
		CN130				M12: Beat Drive M		
		CN130				M12: Beat Drive M		
		CN131				M13: Beat Transfer M		
		CN125				M13: Beat Transfer M		
		CN133				M14 Return Drive M		
		-				M14 Return Drive M		
		CN118				M15: Return Drive M		
		CN119				M15: Return Drive M		
		CN610				M16: Jogger M		
	CN710				M16: Jogger M			
	CN710				M17: Release M			
	CN132				M17: Release M			
					M18: Holder M			
					M18: Holder M			
					M18: Holder Front M			
					M20: Holder Rear M			
					M20: Holder Rear M			
					M21: Stapler Front/Rear M			
					M21: Stapler Front/Rear M			
					M22: Stapler			

					Opposite Corner M M23: Staple M M24: Leading Edge Stopper M M25: Movable Fence M - M27: Upper Transfer M M28: Lower Transfer M M29: Punch M M30: Shift Jogger M M31: Shift Jogger Retracted M SOL1: Shooter Open/Close SOL		
--	--	--	--	--	--	--	--

### 32.1.4 COMPONENT LAYOUT

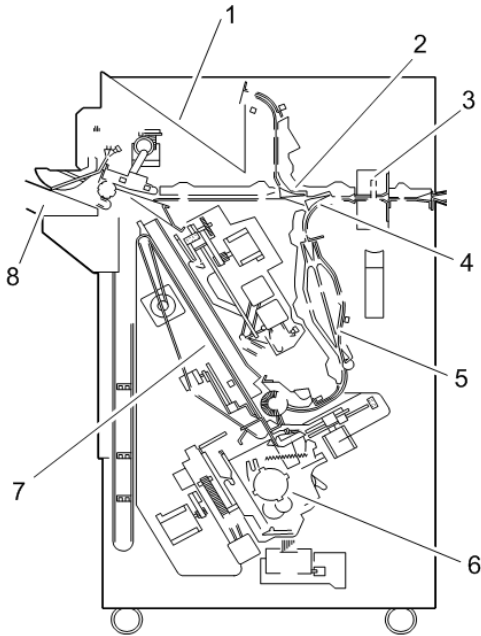

B830v500

- 416. Proof Tray
- 417. Proof Junction Gate
- 418. Punch Unit
- 419. Staple Junction Gate
- 420. Pre-stack Tray
- 421. Stapler
- 422. Staple Unit
- 423. Shift Tray

- Inverter Part  
Distributes paper to the proof tray, the shift mode, or the staple mode. The destination varies depending on the paper sorted or stapled, or not.
- Press Tuck Tray  
At the time of staple mode of more than two sheets, 1st to 3rd sheets wait in the press tuck tray and then are transferred to the staple part. The following sheets (4th, 5th...) are sent to the staple tray two by two. This method contributes to waiting time reduction to enhance production in staple operation.  
< Supported Size: A4Y/B5Y/LTY >
- Proof Tray  
The tray to which paper is output when the sort mode or the staple mode isn't chosen
- Shift Tray  
Performs up-down operation depending on the number of output print, and side-shift operation in sort mode
- Staple Tray Jogger  
With the paper leading edge stopper (Supported press tuck size only), the brush roller, the calling roller and the jogger fence, the staple tray jogger performs staple.
- Punch Unit (Not available in MP1350)  
Punches and makes holes, with the punch motor.

### 32.1.5 ELECTRICAL COMPONENT LAYOUT

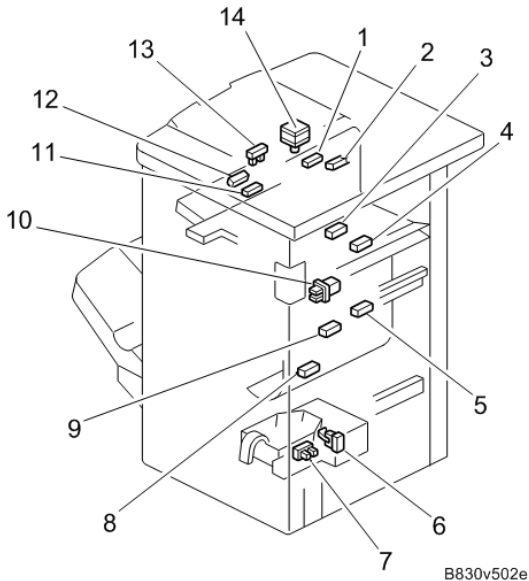

- 424. Proof Exit Sensor
- 425. Proof Full Sensor
- 426. Jam Sensor
- 427. Entrance Sensor
- 428. Pre-stack Sensor
- 429. Used Staple Hopper Set Sensor
- 430. Used Staple Hopper Full Sensor
- 431. Staple Exit Sensor
- 432. Staple Tray Paper Sensor
- 433. Interlock Switch
- 434. Shift Paper Sensor
- 435. Staple Paper Sensor
- 436. Exit Open/close Sensor
- 437. Exit Open/close Motor

Overview

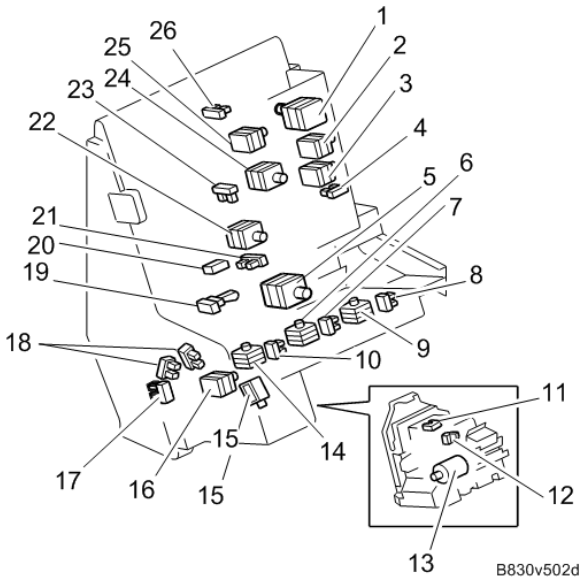

- 438. Leading Edge Stopper Motor
- 439. Drag-in Roller Motor
- 440. Positioning Roller Motor
- 441. Positioning Roller HP Sensor
- 442. Stapler Front/rear Motor
- 443. Paper Hold Center Motor
- 444. Paper Hold HP Sensor
- 445. Paper Hold Rear HP Sensor
- 446. Paper Hold Rear Motor
- 447. Paper Hold Front HP Sensor
- 448. Staple Hammer HP Sensor
- 449. Staple Cartridge Set Sensor
- 450. Staple Motor
- 451. Paper Hold Front Motor
- 452. Used Staple Disposing Solenoid
- 453. Stapler Rotation Motor
- 454. Stapler Movement HP Sensor
- 455. Stapler Rotation Sensor
- 456. Feed Out Belt HP Sensor
- 457. Staple Tray Paper Sensor
- 458. Bottom Fence HP Sensor
- 459. Bottom Fence Motor
- 460. Jogger HP Sensor
- 461. Jogger Motor
- 462. Feed Out Belt Motor
- 463. Leading Edge Stopper HP Sensor

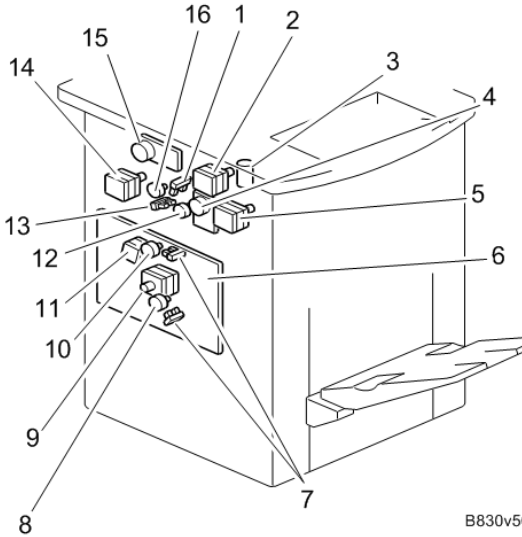

B830v502b

- 464. Staple Junction Gate HP Sensor
- 465. Proof Exit Motor
- 466. Tray Upper/lower Motor
- 467. Lower Transport Motor
- 468. Shift Exit Motor
- 469. Main Controller Board
- 470. Pre-stack Junction Gate HP Sensor
- 471. Pre-stack Junction Gate Motor
- 472. Transport Motor
- 473. Pre-stack Junction Gate
- 474. Vertical Transport Motor
- 475. Proof Junction Gate Motor
- 476. Proof Junction Gate HP Sensor
- 477. Punch Unit Motor
- 478. Upper Transport Motor
- 479. Staple Junction Gate Motor

Overview

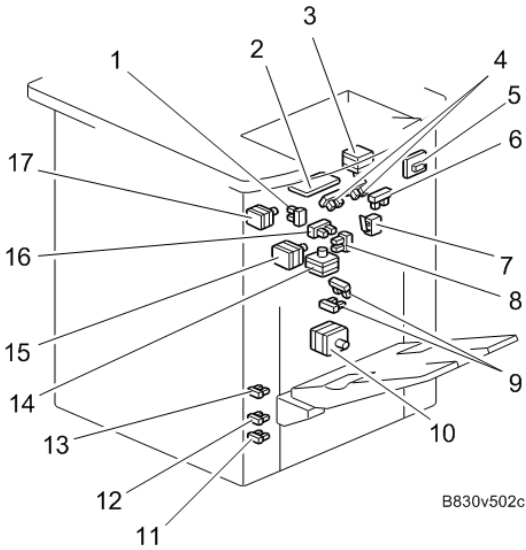

B830v502c

- 480. Jogger HP Sensor
- 481. PCB
- 482. Jogger Motor
- 483. Shift Paper Sensor
- 484. PCB
- 485. Staple Paper Sensor
- 486. Emergency Stop Switch
- 487. Drag-in Drive HP Sensor
- 488. Shift Tray HP Sensor
- 489. Shift Motor
- 490. Tray Lower Limit Sensor
- 491. Tray Near-limit Sensor
- 492. Tray Lower Sensor
- 493. Drag-in Drive Motor
- 494. Drag-in Transport Motor
- 495. Paper Sensor
- 496. Jogger Motor

### 32.1.6 DRIVE LAYOUT

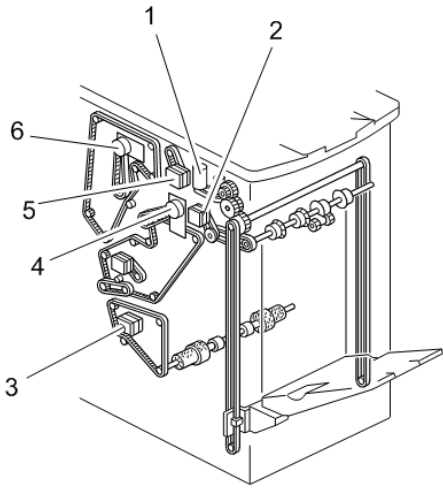

B830v503

- 497. Tray Shift Motor
- 498. Shift Exit Motor
- 499. Staple Transport Motor
- 500. Lower Transport Motor
- 501. Proof Exit Motor
- 502. Upper Transport Motor

## Overview

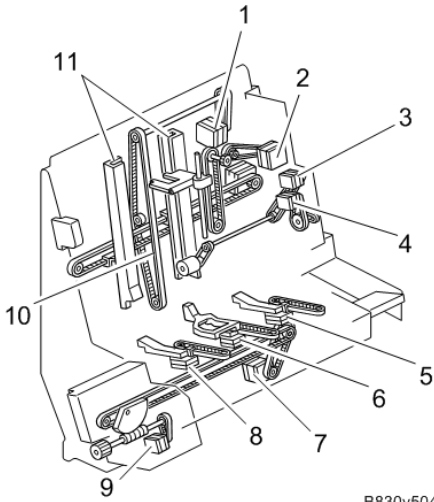

B830v504

- 503. Feed Out Motor
- 504. Jogger Motor
- 505. Drag-in Roller Motor
- 506. Positioning Motor
- 507. Paper Hold Rear Sensor
- 508. Paper Hold Center Motor
- 509. Stapler Front/Rear Motor
- 510. Paper Hold Front Motor
- 511. Staple Rotation Motor
- 512. Feed Out Belt
- 513. Jogger Fence

## 32.2 MECHANISM DETAILS

### 32.2.1 INVERTER

The inverter part has two of inverter plates that lead paper to one of three ways. When proof tray output, the STM of the proof invert plate drives to send paper to the proof tray. In shift mode, paper is sent to the shift tray without two of the STM driving. In staple mode, paper is sent to the staple part with only the STM of the staple invert plate driving.

#### In Proof Mode

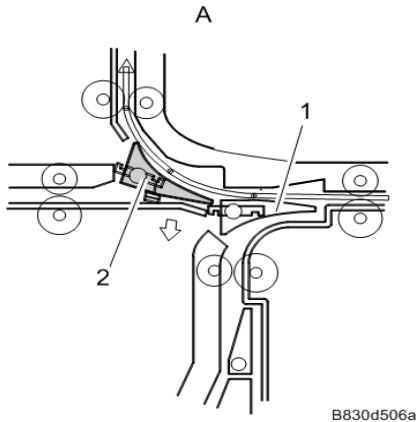

- 514. Proof Junction Gate
- 515. Staple Junction gate

#### In Shift Mode

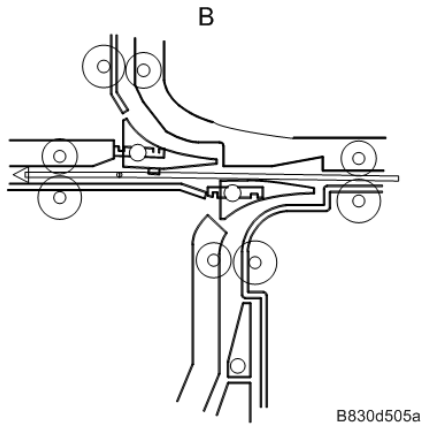

Mechanism Details

In Staple Mode

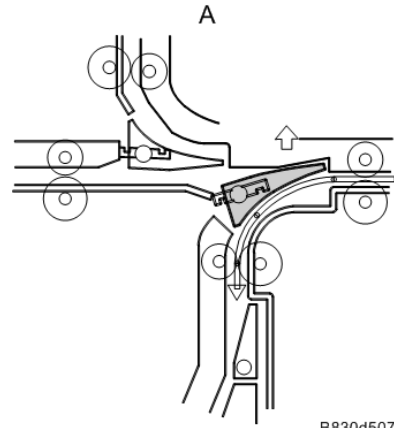

B830d507a

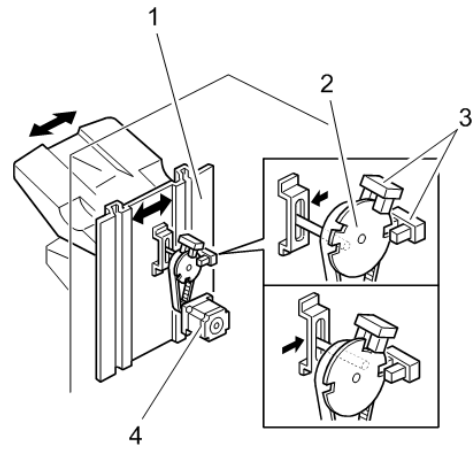

B830d520

- 516. Shift Tray Plate
- 517. Crank Gear
- 518. HP Sensor
- 519. Shift Motor

### 32.2.2 SHIFT TRAY

- **Shift Tray**

In shift mode when the last printed paper output, the shift tray performs shift tray operation, where the crank gear moves to the next HP position and the crank shaft moves left and right. Then the shift tray plate shifts left and right. The shift amount is 15mm.

- **Up / Down**

The shift tray performs up / down depending on the number (the stack height) of output paper. The degree of up or down is adjusted to keep the paper face feeler on the place where both the paper shift sensor and the staple paper face sensor are OFF state (Between the shift sensor and face sensor in the picture below).

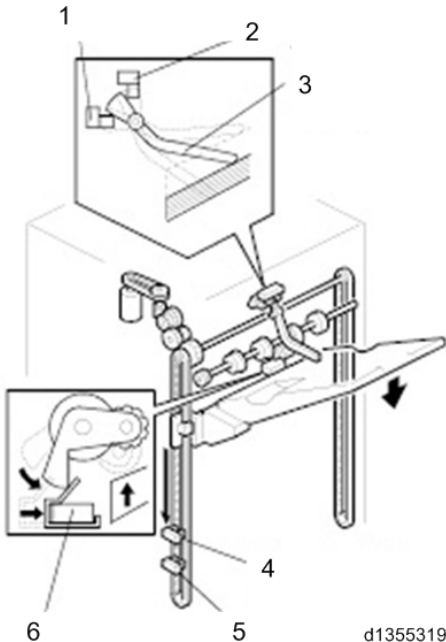

- 520. Shift Paper Sensor
- 521. Staple Paper Sensor
- 522. Paper Sensor Actuator
- 523. Tray Lower Sensor
- 524. Tray Lower Limit Sensor
- 525. Paper Sensor

- **Shift Up**

Paper is removed from the shift tray and the staple paper-face sensor turns ON. Then the shift tray lifts up until the sensor turns "OFF".

- **Shift Down <Shift Mode>**

With stacked paper on the tray, the paper-face sensor is turned "OFF". Then the tray up/down motor turns "ON" to lift the tray until the sensor turns "ON".

- **Shift Down <Staple Mode>**

When paper output, the tray up/down motor keeps ON in a certain time to shift-down the tray. Then until the staple paper face sensor turns "ON" to "OFF" (Home position), the tray is lifted up to shift it to the home position. This operation is performed every time when paper output. There are three of lower sensors but the tray lower sensor and the tray lower larger size sensor are used for the machine display.

Rough Indication:

Larger Size (more than B4): 1,500 sheets  
 Smaller Size (Less than B4): 3000 sheets

▪ **Return Roller Operation**

To enhance the accuracy of paper straightening on the tray, the return roller mechanism is added. The return drive motor with the roller attracts paper on the tray to the tray end fence side.

**32.2.3 PRE-STACK**

◆ **Three Sheets Pre-stack**

526. The rear edge of 1st sheet of paper of 1st unit passes by the entrance sensor. Then the left and the right press tack invert plate shift to the left and close the 2nd and the 3rd path to send paper to the 1st path.

527. The rear edge of 2nd sheet of paper passes by the entrance sensor and the press tack invert plate (Right) shifts to the right to open the 2nd path to send 2nd sheet to the path.

528. The rear edge of 2nd sheet of paper passes by the entrance sensor and the press tack invert plate (Left) shifts to the right to open the 3rd path to send 3rd sheet to the path. Then after the leading edge of the press tack sensor passes by the press tack sensor, three sheets of paper (1st, 2nd, 3rd) are transferred to the staple tray. This method saves the wait time for staple to enhance the copy production.

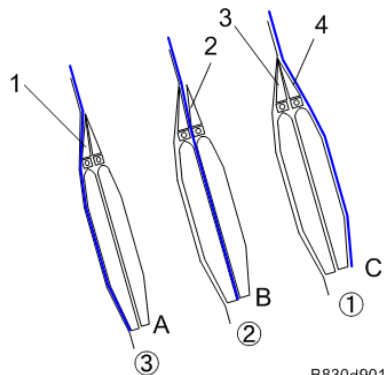

529. Junction Gate (JG) Left

530. JG Right

531. JG Left

532. JG Right

A: 3rd Transport Path

B: 2nd Transport Path

C: 1st Transport Path

◆ **Constant Pre-stack**

The rear edge of 4th sheet of paper passes by the entrance sensor and the press tack invert plate (Left) shifts to the left to open the 2nd path to send 4th sheet to the path. Then after the leading edge of the press tack sensor passes by the press tack sensor, the press tack invert plate (Left) shifts to the right to open the 3rd path to send 5th sheet to the path. And when the leading edge of paper passes by the press tack sensor, sheets of paper are sent to the staple tray two by two.

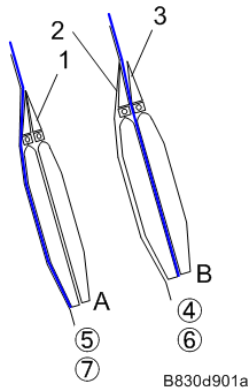

533. Junction Gate (right)

534. JG Left

535. JG Right

A: 3rd Transport Path

B: 2nd Transport Path

## 32.2.4 STAPLE TRAY JOGGER

### 536. Stack

Copy paper that is sent to the staple tray by the brush roller is conveyed to the staple tray. The press tack size that holds the leading edge of the paper with using the leading stopper, straighten stacked paper. It should be noted that, subsequent printed sheets later than 50 sheets are supported by the calling roller not to drop paper. After the staple output sensor was OFF other sizes (A4: 55 ~ 65ms rear), the bumping motor drives a certain amount and straighten the rear edge of paper with pressing it against the reference fence of the tray. At that time, the brush roller performs paper guide to the stopper.

### 537. Jogger

Jogger stack operation straightens the rear edge of paper. Then jogger operation affects the side. ON signal of the main machine (copy start) orders the jogger fence to wait with a 7.2mm off from each side width of paper. The rear edge of the paper that is conveyed passes by the staple output sensor, and the jogger fence closes by 3.7mm inward to straighten the rear edge of paper (Stack). Then the jogger fence closes by 3.5mm inward to straighten the side edge. When the operation is completed, jogger fence state turns wait mode with a 7.2mm off from each side width of paper until the next operation.

From the front and the rear edge, the plate spring extends to enhance the margin of straightening.

### 538. Paper Holding

To staple maximum 100 sheets of paper, the machine holds paper not to let it float. When the jogger returns to the home position from the edge of paper, the paper holding motor operate the paper holding plate to hold paper. The next following sheet turns the staple output sensor OFF and the paper holding motor is turned ON to return the paper holding plate back to the home position. The home position is detected with the paper holding HP sensor. This process is done one by one per sheet, where both the paper holding moves both to the front and the rear but the front and the rear paper holding holds the curl part of paper.

Because the front and the rear paper holding cannot operate at the area where a stapler is there (Stapled area), the holding operates only in the case when a stapler isn't there one by one per sheet. The central paper holding operate constantly regardless the location of a stapler.

Mechanism Details

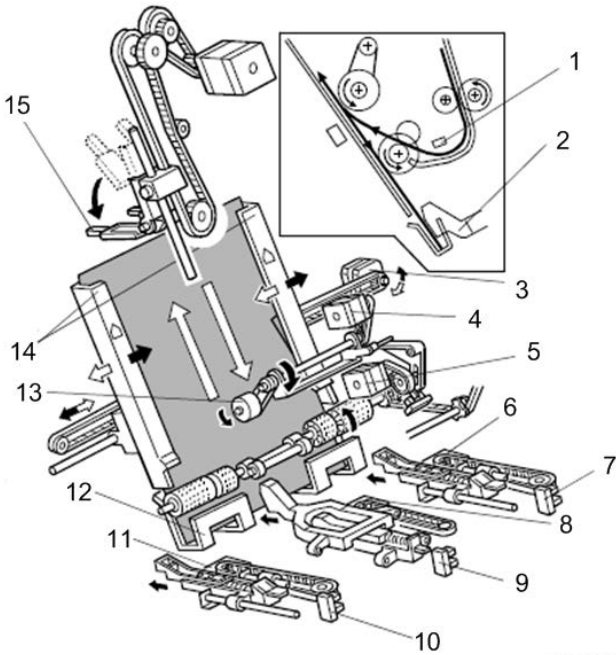

B830d508

- 539. Staple Exit Sensor
- 540. Paper Holder
- 541. Jogger Motor
- 542. Drag-in Roller
- 543. Positioning Roller
- 544. Paper Hold Motor
- 545. Paper Hold Rear HP Sensor
- 546. Paper Hold Motor
- 547. Paper Holder HP Sensor
- 548. Paper Hold Front HP Sensor
- 549. Paper Hold Front Motor
- 550. Bottom Fence
- 551. Drag-in Roller
- 552. Jogger Fence
- Leading Edge Stopper

- **At Front Stapling:** Center + Rear
- **At Rear (Rear Corner) Stapling:** Front + Center
- **At 2-area Stapling:** Front + Center + Rear

## 32.2.5 STAPLE

### ◆ Stapler

The drive motor in the stapler performs staple operation. If motor overload occurs such as staple jam, operation panel shows jam detection. The stapler has a cartridge set sensor and a staple end sensor which cause the panel to show staple supply requirement if staple end (Staple shortage) occurs while coping. If staple jam occurs, copy operation stops. You can remove a jammed staple with releasing the curved part in the picture below.

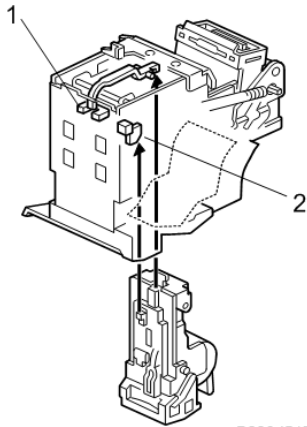
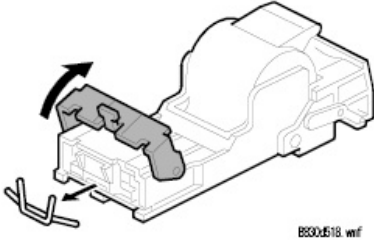

553. Staple Cartridge Set Sensor

554. Staple End Sensor

### ◆ Staple Cut

This machine's stapler uses longer staple needles to do a hundred sheets stapling. When a few sheets, it cuts needles to eliminate remaining extra part. When staple operation, the extra part of needles is cut. The cut extra part is send to the waste staple needle tray. After 1-job end, the solenoid next to the stapler opens the lever to dump the cut extra part to the waste staple needle popper. The popper downs and causes to show the waste staple needle full at the time of tray full detection where the machine requires user to dispose of stored waste needles.

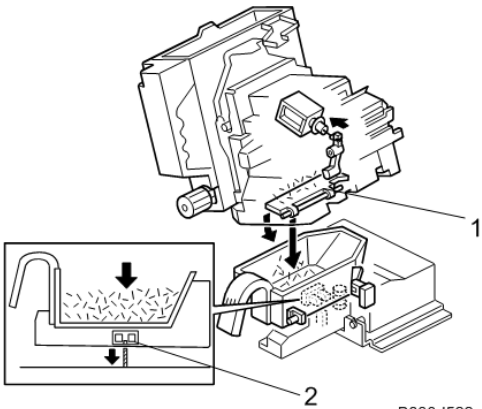

B830d522

- 555. Used Staple Tray
- 556. Used Staple Full Sensor

◆ **Stapler Shifting**

The stapler performs horizontal shift or rotation depending on the four of the staple mode.

- **Staple Shifting**

A rod supports the stapler which shifts to the horizontal direction with a timing belt. The home position of the staple is the front side. When 2-area staple, the stapler staples the front side first and then shifts to the rear side to staple there.

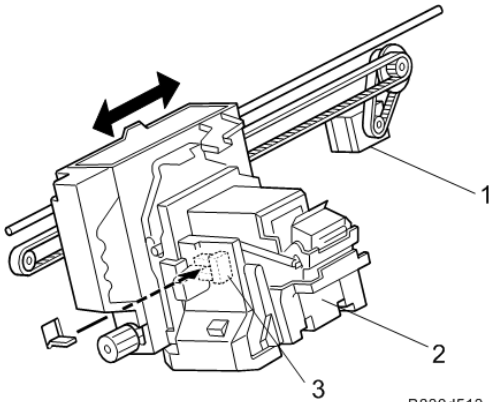

B830d513

- 557. Stapler Movement Motor
- 558. Staple
- 559. Stapler Movement HP Sensor

◆ **Staple Rotation**

When the corner rear staple mode, the stapler shifts to the corner and wait to staple after horizontal shift. The staple rotation motor performs the shift.

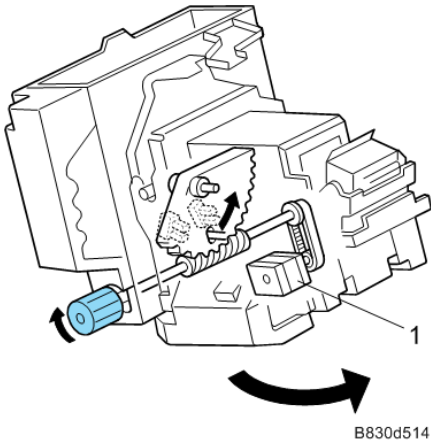

560. Stapler Rotation Motor

◆ **Z-folding Staple**

The shifting fence moves before transferred paper is stacked.

The leading edge stopper stops at the area which is suitable for the size.

Paper is supplied and the leading edge of Z-folded paper bumps on the leading straitening board.

The calling roller drops paper and it is stacked on the shifting fence.

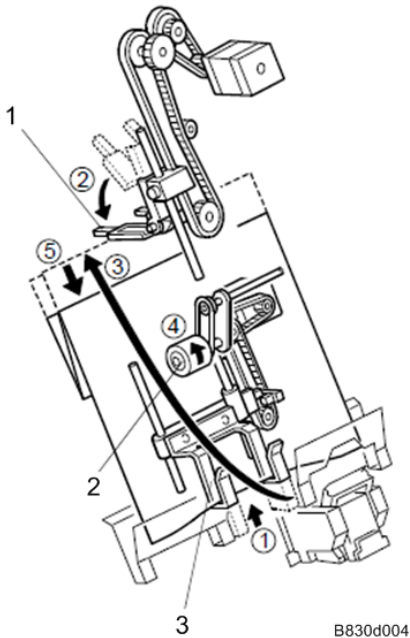

561. Leading Edge Stopper

562. Drag-in Roller

563. Bottom Fence

When the specified amount of paper is stacked, the shifting fence downs. And the leading stopper also downs to straighten the leading edge of paper.

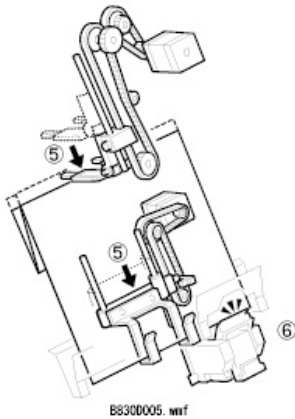

◆ **Output Exit Open/Close**

This machine opens the output exit when output paper in order to output max one hundred stapled sheets of paper to the tray.

When staple turns ON, the output exit open/close motor turns OFF to open the exit, where the release motor turns ON after staple turns OFF. And the ejection belt drives and the ejection paw attached on the belt sends the bulk of paper to the exit and the shift tray. After a certain time from the staple OFF, the output exit open/close motor turns ON to close the exit, where the bulk of paper is output to the shift tray by the exit roller.

Staple mode performs exit open/close operation when more than sixteen sheets of paper need to output.

OFF timing for the output exit open/close motor depends on the disk on the output exit open/close motor and sensor.

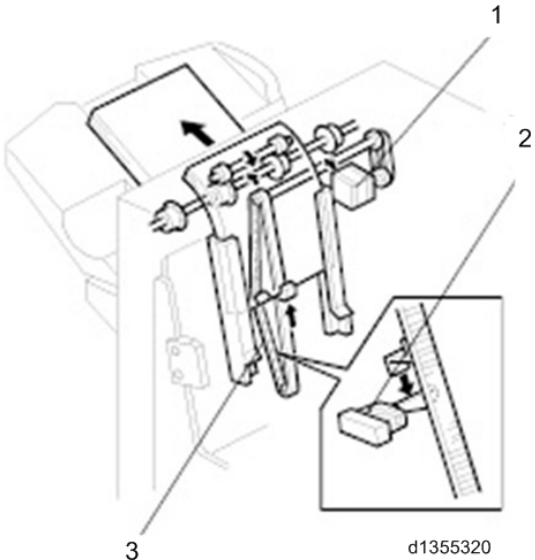

- 564. Feed Out Motor
- 565. Feed Out Belt HP Sensor
- 566. Feed Out Belt

d1355320

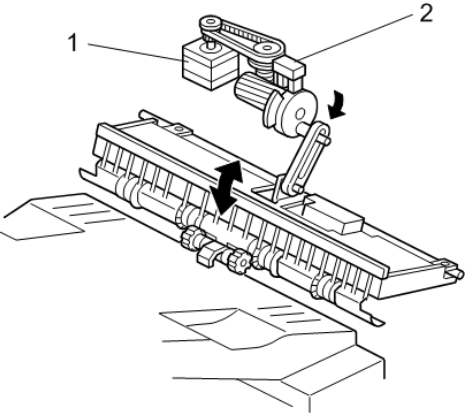

- 567. Exit Open/close Motor
- 568. Exit Open/close Sensor

B830d512

## 32.2.6 PUNCH (2-HOLE PUNCH UNIT)

\*MP1350 cannot punch

Punch applies one by one sheet. 2-hole punch applies to the rear edge of paper.

\*By UP mode switch, 3-hole punch is enabled.

- Punch Drive

The punch motor drives the punch unit where the punch axis rotates in accordance with copy paper transport to punch it. The punch axis waits at the home position. After the finisher entrance sensor detects the rear edge of paper (OFF), the motor drives to punch at the specified timing. The adjustment of the punch area is done by SP mode and the spacer.

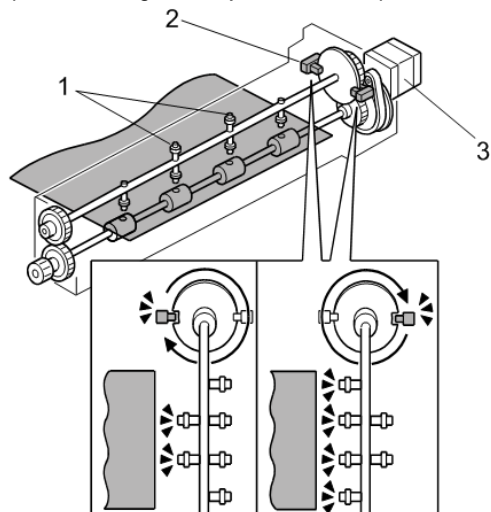

B830d102

569. Punch Tooth

570. Punch Shaft HP Sensor

571. Punch Motor

- Punch Waste Collection

Punch waste is collected with the popper installed under the punch unit. The popper unit has a full detection sensor which detects full when punch waste is piled up to the sensor. In this time, the operation panel shows full detection at the end of copy job.

And the punch waste popper has a set detection sensor to alert that "the popper is not set" when the popper is not placed.

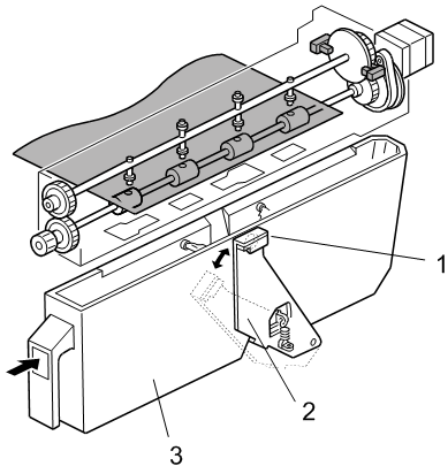

B830d103

572. Used Staple Full Sensor  
 573. Sensor Bracket  
 574. Used Staple Hopper

	Parts Name	Function
1	Vertical Shift Motor	The stepping motor that drives the straightening arm vertically
2	Horizontal Shift Motor	The stepping motor that drives the straightening arm horizontally
3	Main Drive Belt	The belt that relays horizontal motor drive to the gear
4	Gear	The gear that relays main motor belt to the relay drive belt
5	Relay Drive Belt	The belt that repeats right-left rotation in accordance with the straightening arm
6	Straightening Arm	The arm that straightens the edge face of paper with open and close
7	Sensor 1	The sensor that detects the horizontal home position of the straightening arm (edge face)
8	Sensor 2	The sensor that detects the vertical home position of the straightening arm (lower)
9	Vertical Detector	Interrupts the detecting sensor 1
10	Horizontal Detector	Interrupts the detecting sensor 2

The home position of the straightening arm is on the output exit where the arm waits. Just before finisher tray ejection, the arm downs. After ejection, it straightens the edge face of paper (open/close repetition).

The straightening arm repeats up-down operation in accordance with the amount shift of the finisher tray. At the end of the copy ejection, the arm returns to the home position to be ready to do the next operation. The sizes that can be straightened are as follows;

**Non-Folded:** A3~A5, DLT~HLT, 12"x18", 13"x14"

**Z-Folded:** A3, B4, A4 SEF, DLT, LG, LT LEF

### 32.2.7 JAM DETECTION

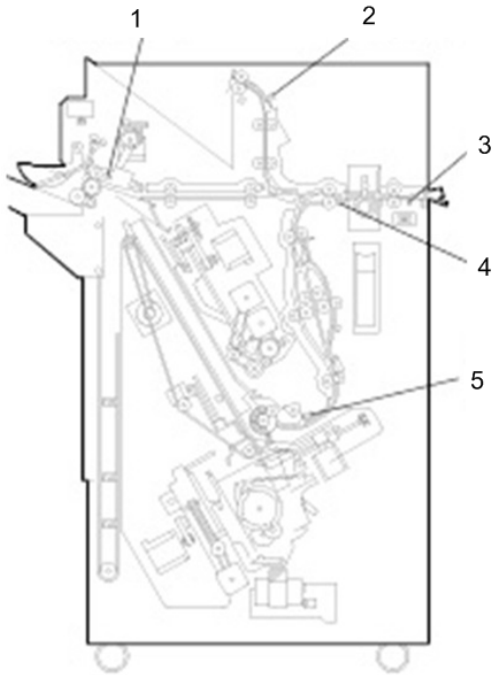

d1355321

- 575. Shift Tray Exit Sensor
- 576. Proof tray Exit Sensor
- 577. Entrance Sensor
- 578. Jam Sensor
- 579. Staple Tray Exit Sensor

Type	Relevant Sensor	Detecting Condition
Detention	Entrance Sensor	Paper turns the sensor ON but not turns the sensor OFF after paper passes 1.5 times length of paper.
	Proof Output Sensor	
	Shift Tray Output Sensor	
	Staple Tray Output Sensor	
Unreachable	Entrance Sensor	After the main machine exit sensor turns ON, the entrance sensor doesn't turn ON even when paper passes 426 mm.
	Proof Exit Sensor	After the entrance sensor turns ON, the proof output sensor doesn't turn ON even when paper passes 574 mm.
	Shift Tray Output Sensor	After the entrance sensor turns ON, the shift tray output sensor doesn't turn ON even when paper passes 733 mm.
	Staple Tray Output Sensor	After the entrance sensor turns ON, the staple tray output sensor doesn't turn ON even when paper passes 835 mm.

**32.2.8 DIP SW**

DPS101				Contents
1	2	3	4	
0	0	0	0	Default
1	0	0	0	System Free Run
0	1	0	0	Lasting Free Run
0	0	1	0	Package Free Run
0	0	0	1	Shift Free Run

## 33. OUTPUT JOGGER UNIT TYPE M2 (D705)

### 33.1 MACHINE DESCRIPTIONS

#### 33.1.1 LAYOUT



	Name	Function
1	Vertical-move Motor	The stepping motor that moves the jogger in vertical direction
2	Side-to-side-move Motor (Left)	The stepping motor that moves the jogger (Left) side-to-side
3	Side-to-side-move Motor (Right)	The stepping motor that moves the jogger (Right) side-to-side
4	Main Drive Belt	The belt with which the horizontal motor drives the gears
5	Gear	The gear with which the main drive belt drives the relay drive one
6	Relay Drive Belt	The belt that is engaged with the joggers moves to right and left repeatedly
7	Joggers	The fences that performs Open / Close operation to tidy the edges face of the stacked sheets
8	Detection Sensor 1	Detects the jogger (side) HP
9	Detection Sensor 2	Detects the jogger (bottom) HP
10	Side-to-side Feeler	Interrupts the detection sensor 1
11	Vertical Feeler	Interrupts the detection sensor 2

## 33.2 MECHANISM

The joggers are ready at the home position that is the top of the paper exit.

The joggers down just before the copier output paper from the exit. Then they tidy the side edge face of the stack (repeating open / close)

The joggers repeat to lift up/down in accordance with finisher tray shift. When the last output finishes, the jogger returns to the home position.

In this machine, jogger operation can be applied to the following sizes; A5Y, B5Y, A4Y, A4T, B4T, A3T, HLTY, LTY, LTT, LGT, DLTT, 12"×18".

## 34. Z-FOLDING UNIT

### 34.1 OVERVIEW

Item	Descriptions
Available Machine	3000 sheets finisher SR4090, 2000 sheets booklet finisher SR4100, 3000 sheets finisher SR4110
Type	Console
Output Tray	None
Transport Standard	Center
Main Machine Output Paper Face	Back Face
Folding Type	Z-Fold
Z-Folding Supported Paper Size	A3 SEF, B4 SEF, A4 SEF, 11" x 17" SEF, 8 <sup>1</sup> / <sub>2</sub> " x 14" SEF, 8 <sup>1</sup> / <sub>2</sub> " x 11" SEF 12 x 18 SEF
Supported Paper Thickness	64~80g/m <sup>2</sup> (55~69kg)
Power Source	100V, 1A, 50/60Hz
Max Power Consumption	100W (Another power source required)
Dimensions (W x D x H)	177x620x960mm
Weight	Approximately 55 kg

#### 34.1.1 GENERAL

This unit is for Z-folding applying to paper that comes from the main machine.

Supported size is as follows: A3 SEF, B4 SEF, DLT SEF, LG SEF, LT SEF, 12 x 18 SEF

### 34.1.2 OVERVIEW LAYOUT

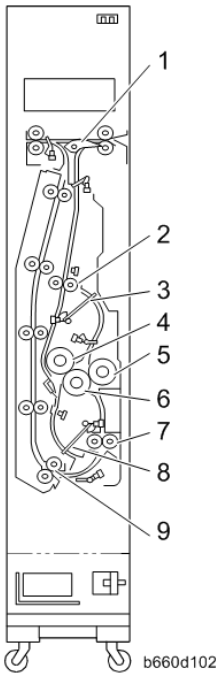

- 580. Flapper (Junction Gate)
- 581. Transport Roller
- 582. Upper Stopper
- 583. 1st Fold Roller
- 584. 2nd Fold Roller
- 585. 3rd Fold Roller
- 586. 1st Crease Roller
- 587. Lower Stopper
- 588. 2nd Crease Roller

### 34.1.3 ELECTRICAL COMPONENTS LAYOUT

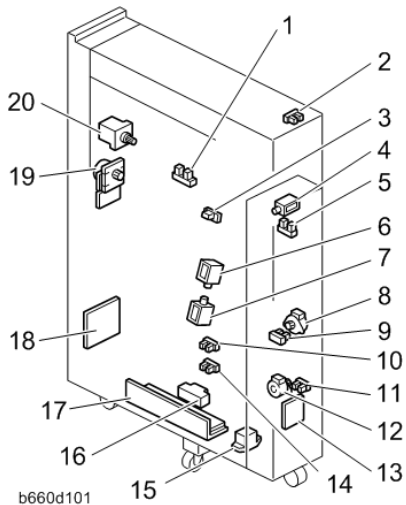

b660d101

- 589. Exit Sensor
- 590. Upper Cover Sensor
- 591. Pressure Timing Sensor
- 592. Flapper Solenoid
- 593. Feed Sensor
- 594. Separation Solenoid
- 595. Pressure Solenoid
- 596. Upper Stopper Motor
- 597. Upper Stopper HP Sensor
- 598. Upper Stopper Path Sensor
- 599. Lower Stopper HP Sensor
- 600. Lower Stopper Motor
- 601. Relay Board
- 602. Separation Timing Sensor
- 603. RA
- 604. Circuit Breaker
- 605. PSU
- 606. Main Controller Board
- 607. Fold Motor
- 608. Stratigh Path Motor

### 34.1.4 DRIVE LAYOUT

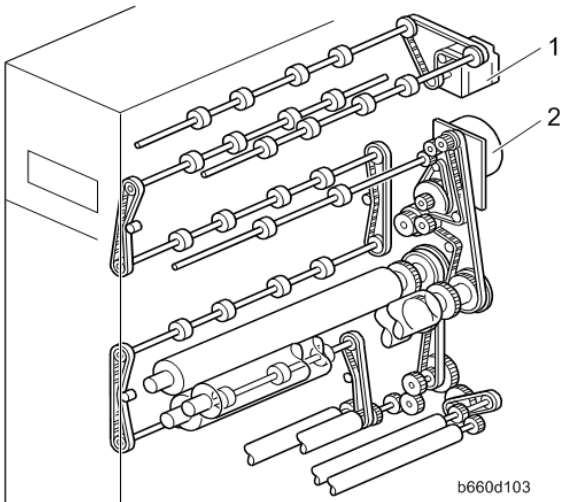

- 609. Straight Path Motor
- 610. Crease Motor

b660d103

## 34.2 DETAILS

### 34.2.1 FOLDING

Receiving signal from the mainmachine turns the straight-pass motor and the folding motor ON and then the upper stopper and the lower one shifts to the HP.

After that, the stopper shifts to the proper area depending on the size.

The flapper solenoid turns on and the flapper opens and then paper is sent into the folding unit. On this way, the separation solenoid turns ON and the sending roller loses its sending power.

Paper bumps onto the lower stopper to correct its skew.

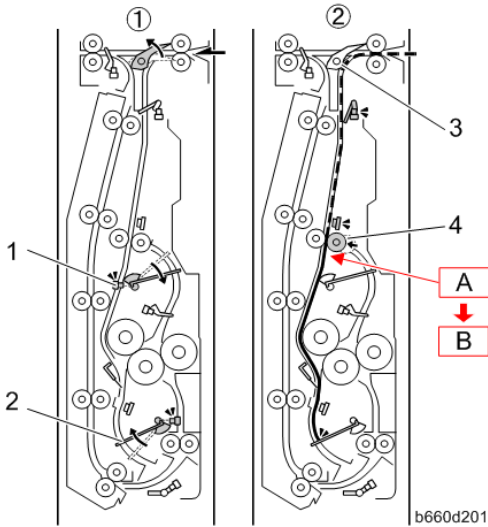

611. Upper Stopper

612. Lower Stopper

613. Flapper

614. Transport Roller

**A:** Separation Solenoid turns on

**B:** Skew Correction

The press solenoid turns ON (separation solenoid turns OFF) and the sending roller presses the paper to enhance the power of transport. And the paper transport continues and deflection will occur.

From the deflected area on the paper, the paper is held between the 1st-folding roller and the 2nd-folding. 1st-folding finishes and the paper is transported.

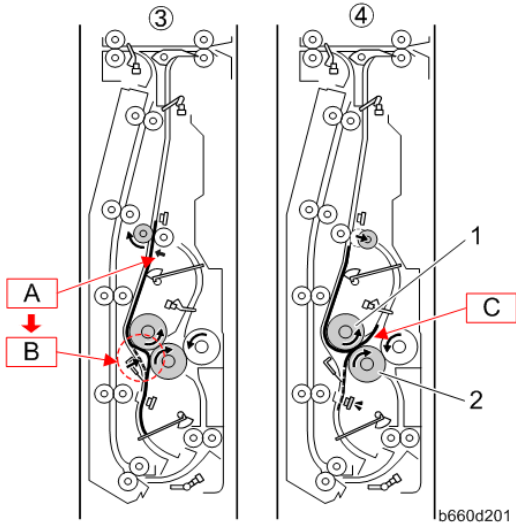

- 615. 1st Crease Roller
- 616. 2nd Crease Roller
- A: Pressure Solenoid On
- B: Deflection occurs
- C: 1st Fold

b660d201

The folded paper bumps onto the upper stopper.  
 As 1st-folding, the paper that bumps onto the upper stopper continues to be transported and is given deflection.

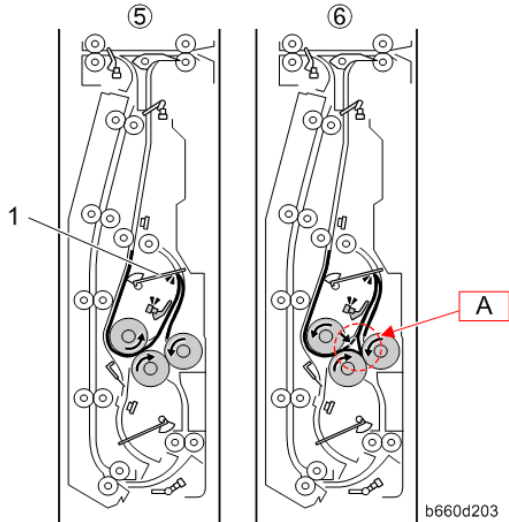

- 617. Upper Stopper
- A: Deflection occurs

b660d203

From the deflected area on the paper, the paper is held between the 2nd-folding roller and the 3rd-folding. 2nd –folding finishes.  
 The completed paper is sent to the finisher while being given add-fold with the 1st fold-adding

Details

roller and the 2nd fold-adding one.

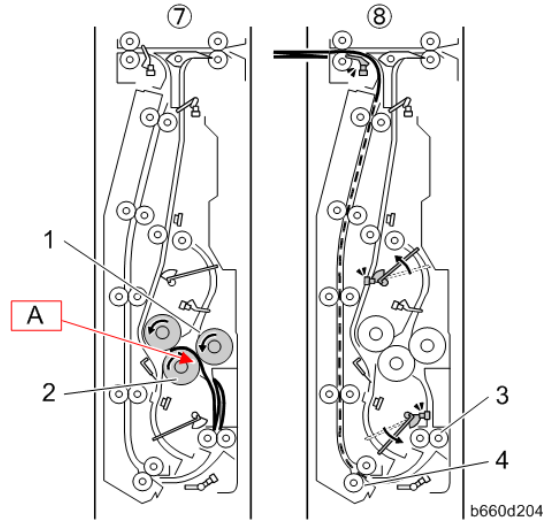

- 618. 3rd Fold Roller
- 619. 2nd Fold Roller
- 620. 1st Crease Roller
- 621. 2nd Crease Roller
- A: 2nd Fold

### 34.2.2 Z-FOLDING AREA ADJUSTMENT

You can adjust the area depending on the size.

◆ **UP Mode Adjustment**

“System Initial Setting” → “Setting” → “Z-Folding Adjustment”



Size	Adjustable Range of “A”
A3 SEF	2~25mm
B4 SEF	2~40mm
A4 SEF	2~10mm
DLT SEF (11”x17”)	2~20mm
LG SEF (3 1/2”x14”)	2~35mm
LT SEF	2mm
12”x18”	2~5mm
Others	2mm

\*All of the defaults are 2mm

◆ **SP Mode Adjustment**

SP6-301-001 ~ 008: Z-Folding Minor Adjustment (End) → “A” Adjustment

SP6-301-009 ~ 016: Z-Folding Minor Adjustment (Outline) → “L1” Adjustment

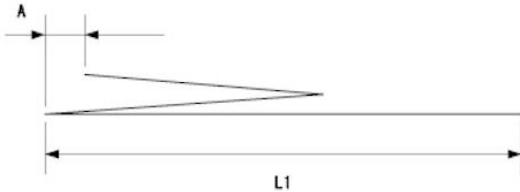

\*Minus (-) means to reduce the length of L1, while plus (+) means to increase it. All of the defaults are 0 mm.

Size	Adjustable Range of “A” (SP6-301-xxx)	Adjustable Range of “L1” (SP6-301-xxx)	Each size L1 (Target value)
A3 SEF	±4.0mm (001)	±4.0mm (009)	210mm
B4 SEF	±4.0mm (002)	±4.0mm (010)	182mm
A4 SEF	±4.0mm (003)	±4.0mm (011)	148.5mm
DLT SEF	±4.0mm (004)	±4.0mm (012)	215.9mm
LG SEF	±4.0mm (005)	±4.0mm (013)	177.8mm
LT SEF	±4.0mm (006)	±4.0mm (014)	139.7mm
12” x 18”	±4.0mm (007)	±4.0mm (015)	228.6mm
Others	±4.0mm (008)	±4.0mm (016)	

### 34.2.3

### 34.2.4 Z-FOLDING GAP ADJUSTMENT

As shown below, the Z-folding gap adjustment is available on the 1st and 2nd folding.

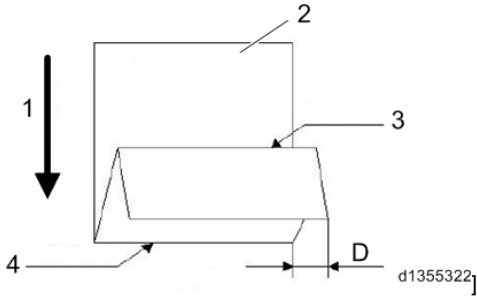

- 622. Transport Direction
- 623. Printed Face (simplex)
- 624. 1st Fold
- 625. 2nd Fold

#### ◆ Adjustment Mechanism

By rotating the adjustment screw that moves in accordance with the paper stopper, you can adjust.

- 626. The adjustment screw for 1st folding gap  
It locates in the back of the right door of the Z-folding unit.

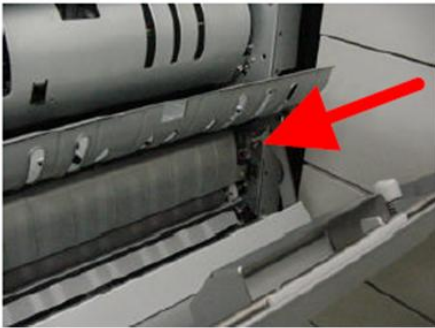

d1355323

- 627. The adjustment screw for 2nd folding gap  
It locates in the back of the left door of the Z-folding unit.



d1355324

#### ◆ How to adjust

- STEP1** See the gap of "1st-folding" after place the Z-folded paper on a flat surface

and open “2nd-folding”.

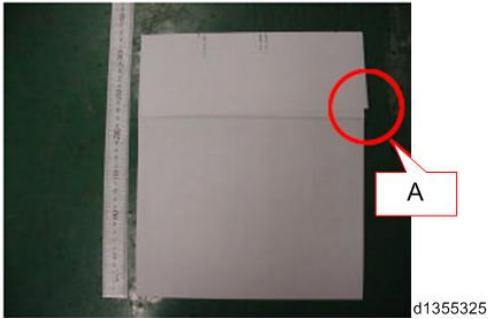

A: Fold Gap

**STEP2** To adjust 1st-folding gap, withdraw “the drawer unit” and open the right door. And then insert a class slot screwdriver into “the 1st-folding adjustment screw” to fix it and rotate it to the left and loose it.

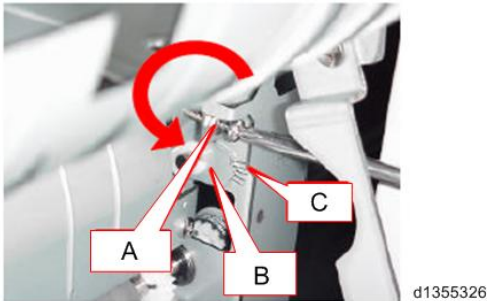

A: Screw  
B: Adjustment Plate  
C: Calibration

**STEP3** In case that the paper protrude to the right side as shown in the picture 4 above, rotate “the 1st-folding adjustment screw” to the right. When the sticking-out-part is the left, rotate the screw to the left. “The adjustment screw” rotates in accordance with “the adjustment plate”. Refer to the calibrations carved in the frame to decide the amount of adjusting. The amount of stiking-out changes about 1 mm per calibration

**STEP4** Close the right door and reinstall the drawer unit.

**STEP5** Operate Z-folidng again to check the gap.

**STEP6** If necessary, repeat “procedure 3 to 5” to complete adjustment.

**STEP7** After the adjustment, tighten the screw that has been loosen at “procedure 2” \*Be sure to fix the screw with a screwdriver not to let it rotate.

**STEP8** Then perform “2nd-folding gap adjustment”. See the gap of “2nd-folding” after place the Z-folded paper on a flat surface and open “1st-folding”.

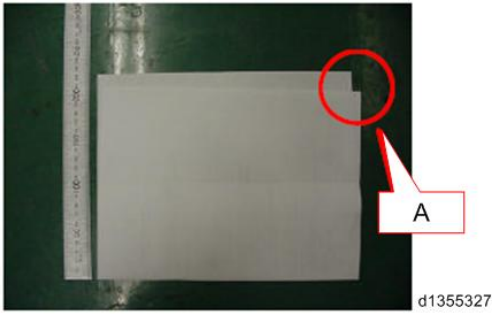

A: Fold Gap

**STEP9** As does in the “1st-folding” gap adjustment, loose “the 2nd-folding adjustment screw” to the either direction. Place the sheets as shown in the pic 6 above. If there is a right gap, rotate the adjustment screw clockwise and vice verse (for a left gap, rotate counter-clockwise). Refer to the calibrations carved in the frame to decide the amount of adjusting. The amount of stiking-out changes about 1 mm per calibration

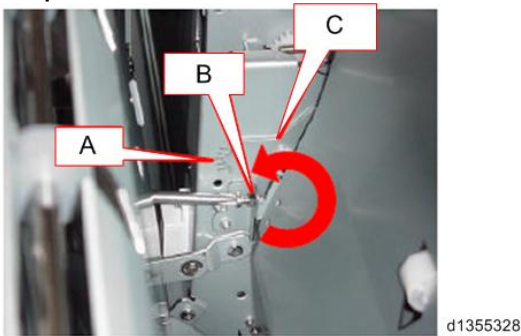

A: Calibration  
 B: Screw  
 C: Adjustment Plate

**STEP10** Close the left door and reinstall the drawer unit. And operate Z-folding and see the gap as “procedure 8”.

**STEP11** If necessary, repeat “procedure 9 to 10” to complete adjustment. After that tighten the screw.

**STEP12** In case that there is something wrong in the accuracy of folding by “folding” adjustment, try the test mode adjustment whose way is written in the service manual

◆ **Adjustment Simplified Chart**  
 628. “1st-folding” gap adsutment

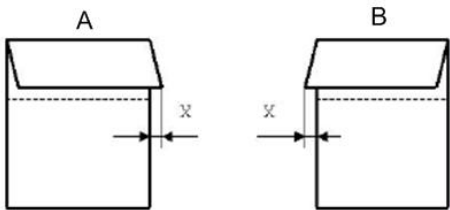

A: In case the upper area of paper comes to the rightside too much, rotate the adjustment

screw to the right

**B:** In case the upper area of paper comes to the leftside too much, rotate the adjustment screw to the left

629. "2nd-folding" gap adjustment

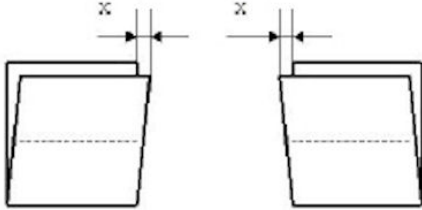

\* The amount of "X" changes about 1 mm per "calibration" carved on the frame.