

# RICOH



D259

## ***SERVICE MANUAL***

**LANIER RICOH SAVIN®**

It is the reader's responsibility when discussing the information contained within this document to maintain a level of confidentiality that is in the best interest of Ricoh USA, Inc. and its member companies.

***NO PART OF THIS DOCUMENT MAY BE REPRODUCED IN ANY FASHION AND DISTRIBUTED WITHOUT THE PRIOR PERMISSION OF RICOH USA, Inc.***

All product names, domain names or product illustrations, including desktop images, used in this document are trademarks, registered trademarks or the property of their respective companies.

They are used throughout this book in an informational or editorial fashion only and for the benefit of such companies. No such use, or the use of any trade name, or web site is intended to convey endorsement or other affiliation with Ricoh products.

## **WARNING**

*The Service Manual contains information regarding service techniques, procedures, processes and spare parts of office equipment distributed by Ricoh USA, Inc. Users of this manual should be either service trained or certified by successfully completing a Ricoh Technical Training Program.*

*Untrained and uncertified users utilizing information contained in this service manual to repair or modify Ricoh equipment risk personal injury, damage to property or loss of warranty protection.*

*Ricoh USA, Inc.*

# LEGEND

PRODUCT CODE	COMPANY		
	LANIER	RICOH	SAVIN
D259	MP 305+ SP	MP 305+ SP	MP 305+ SP
D259	MP 305+ SPF	MP 305+ SPF	MP 305+ SPF

# DOCUMENTATION HISTORY

REV. NO.	DATE	COMMENTS
*	05/2016	Original Printing



# D259

## TABLE OF CONTENTS

<b>1. PRODUCT INFORMATION .....</b>	<b>1-1</b>
1.1 MACHINE CODES AND PERIPHERALS CONFIGURATION .....	1-1
1.1.1 SYSTEM CONFIGURATION AND OPTIONS.....	1-1
Main Machine and Peripherals.....	1-1
Controller Options .....	1-2
1.2 INSTALLATION .....	1-4
1.3 INSTALLATION REQUIREMENTS.....	1-4
1.3.1 ENVIRONMENT .....	1-4
1.3.2 MACHINE LEVEL.....	1-5
1.3.3 MINIMUM SPACE REQUIREMENTS .....	1-5
1.3.4 POWER REQUIREMENTS.....	1-6
1.4 MAIN MACHINE INSTALLATION .....	1-7
1.4.1 IMPORTANT NOTICE ON SECURITY ISSUES.....	1-7
Overview.....	1-7
Password Setting Procedure.....	1-8
1.4.2 ACCESSORY CHECK .....	1-12
1.4.3 INSTALLATION PROCEDURE .....	1-14
1.4.4 CHECK IMAGE QUALITY / SETTINGS.....	1-17
Loading Paper .....	1-17
Checking the copy image with the test chart .....	1-17
1.4.5 MOVING THE MACHINE .....	1-18
1.4.6 TRANSPORTING THE MACHINE .....	1-18
1.5 PAPER FEED UNIT PB1090 .....	1-19
1.5.1 ACCESSORY CHECK .....	1-19
1.5.2 INSTALLATION PROCEDURE .....	1-20
1.6 DEHUMIDIFICATION HEATERS.....	1-25
1.6.1 DEHUMIDIFICATION HEATER FOR MAIN PAPER FEED TRAY.....	1-25
Accessory Check.....	1-25
Installation Procedure.....	1-26
1.6.2 DEHUMIDIFICATION HEATER FOR OPTIONAL PAPER FEED TRAY .....	1-31
Accessory Check.....	1-31
Installation Procedure.....	1-32
1.7 COPY DATA SECURITY UNIT TYPE G .....	1-39
1.7.1 ACCESSORY CHECK .....	1-39

1.7.2	INSTALLATION PROCEDURE .....	1-40
User Tool Setting .....		1-44
1.8	ENHANCED SECURITY HDD OPTION TYPE M10 (D792-09) .....	1-46
1.8.1	ACCESSORY CHECK .....	1-46
1.8.2	INSTALLATION PROCEDURE .....	1-46
After Installing the HDD .....		1-51
1.9	NFC CARD READER TYPE M15 (D3B4) .....	1-52
1.9.1	ACCESSORY CHECK .....	1-52
1.9.2	INSTALLATION PROCEDURE .....	1-53
1.10	OPTIONAL COUNTER INTERFACE UNIT TYPE M12 .....	1-64
1.10.1	ACCESSORY CHECK .....	1-64
1.10.2	INSTALLATION PROCEDURE .....	1-65
1.11	RICOH E-SHARING BOX (D668) .....	1-70
1.12	CONTROLLER OPTIONS .....	1-71
1.12.1	OVERVIEW .....	1-71
SD Card Slots .....		1-71
USB Port .....		1-72
1.12.2	SD CARD APPLI MOVE .....	1-72
Overview .....		1-72
Move Exec .....		1-72
Undo Exec .....		1-73
Storing the SD Card .....		1-74
1.12.3	BLUETOOTH INTERFACE UNIT TYPE D .....	1-75
1.12.4	OCR UNIT TYPE M13 .....	1-75
Recovery Procedure .....		1-78
1.12.5	XPS DIRECT PRINT OPTION TYPE M15 .....	1-78
1.12.6	DATA OVERWRITE SECURITY UNIT TYPE I .....	1-80
Overview .....		1-80
Before You Begin the Procedure .....		1-80
Seal Check and Removal .....		1-80
Installation Procedure .....		1-81
1.12.7	CHECK ALL CONNECTIONS .....	1-82
1.13	SECURITY SETTINGS .....	1-83
1.13.1	SECURITY FUNCTION INSTALLATION .....	1-83
1.13.2	DATA OVERWRITE SECURITY .....	1-84
Before You Begin the Procedure .....		1-84
Using Auto Erase Memory .....		1-84
1.13.3	HDD ENCRYPTION .....	1-86
Before You Begin the Procedure: .....		1-86

Enable Encryption Setting.....	1-86
Backing Up the Encryption Key.....	1-88
Encryption Key Restoration.....	1-89
1.14 @REMOTE SETTINGS .....	1-91
1.14.1 SETTING PROCEDURE.....	1-91
1.14.2 SP5-816-208 ERROR CODES .....	1-94
1.15 OPERATION GUIDANCE FOR USERS .....	1-96
<b>2. PREVENTIVE MAINTENANCE.....</b>	<b>2-1</b>
2.1 PREVENTIVE MAINTENANCE TABLES .....	2-1
2.2 PM/YIELD PARTS SETTINGS .....	2-1
2.2.1 SET-UP PROCEDURE FOR REPLACING THE PM/YIELD PARTS.....	2-1
<b>3. REPLACEMENT AND ADJUSTMENT.....</b>	<b>3-1</b>
3.1 NOTES ON THE MAIN POWER SWITCH.....	3-1
3.1.1 PUSH SWITCH .....	3-1
Characteristics of the Push Switch (DC Switch).....	3-1
Shutdown Method (How to Turn OFF the Main Power).....	3-2
Forced Shutdown .....	3-3
3.2 BEFOREHAND .....	3-3
3.3 SPECIAL TOOLS AND LUBRICANTS .....	3-4
3.4 QUICK REFERENCE FOR REMOVING MAJOR UNITS .....	3-4
3.5 EXTERIOR COVERS .....	3-5
3.5.1 REAR COVER.....	3-5
3.5.2 RIGHT UPPER COVER.....	3-6
3.5.3 FRONT UPPER COVER.....	3-7
3.5.4 LEFT UPPER COVER .....	3-8
3.5.5 LEFT LOWER COVER.....	3-9
3.5.6 FRONT COVER .....	3-10
3.5.7 OPERATION PANEL REAR COVER.....	3-11
3.5.8 SCANNER REAR COVER.....	3-11
3.5.9 FRONT INNER COVER.....	3-12
3.5.10 PAPER EXIT TRAY .....	3-13
3.6 ARDF.....	3-14
3.6.1 ARDF.....	3-14
After installing a New ARDF.....	3-15
3.6.2 ARDF EXTERIOR .....	3-16
ARDF Front Cover.....	3-16
ARDF Rear Cover .....	3-17
ARDF Feed Cover.....	3-18

Copy Holder.....	3-19
3.6.3 ARDF FEED UNIT.....	3-20
3.6.4 ARDF PICKUP ROLLER.....	3-20
3.6.5 ARDF FEED ROLLER.....	3-21
3.6.6 ARDF FRICTION PAD.....	3-22
3.6.7 DFRB (DF RELAY BOARD).....	3-22
3.6.8 ARDF FEED COVER SENSOR, ORIGINAL SET SENSOR.....	3-23
3.6.9 ARDF ORIGINAL WIDTH SENSOR.....	3-23
Precaution for Installing the ARDF Original Width Sensor.....	3-24
3.6.10 ARDF DRIVE MOTOR.....	3-25
Precautions for Installing the Lower Guide Plate.....	3-29
3.6.11 ARDF PAPER FEED SOLENOID.....	3-30
3.6.12 ARDF REVERSE SOLENOID.....	3-31
3.6.13 ARDF SCANNING GUIDE PLATE, ARDF REGISTRATION SENSOR.....	3-34
Precaution when Installing the ARDF Scanning Guide Plate.....	3-34
3.7 OPERATION PANEL.....	3-35
3.7.1 OPERATION PANEL.....	3-35
3.7.2 INTERNAL PARTS.....	3-36
3.8 SCANNER.....	3-37
3.8.1 SCANNER UNIT.....	3-37
3.8.2 SCANNER FRONT COVER.....	3-38
3.8.3 EXPOSURE GLASS, ARDF EXPOSURE GLASS, LEFT SCALE AND REAR SCALE.....	3-38
Precaution for Installing These Parts.....	3-39
3.8.4 APS SENSOR 1, 2.....	3-41
North America.....	3-41
Others.....	3-42
3.8.5 SCANNER HP SENSOR.....	3-42
3.8.6 TIMING BELT.....	3-43
3.8.7 SCANNER MOTOR.....	3-44
3.8.8 CIS.....	3-46
3.8.9 PLATEN COVER SENSOR, ARDF POSITION SENSOR.....	3-48
3.8.10 SCANNER PARALLEL ADJUSTMENT.....	3-49
3.9 LASER OPTICS.....	3-52
3.9.1 LOCATION OF THE CAUTION DECAL.....	3-52
3.9.2 DUST-SHIELD GLASS.....	3-52
Notes on Installing the Dust Shield Glass.....	3-53
3.9.3 LASER UNIT.....	3-54
Precaution for Installing the Laser Unit.....	3-58

	Parallelogram Image Adjustment .....	3-58
3.10	PCDU .....	3-60
	3.10.1 PCDU.....	3-60
	3.10.2 TONER SUPPLY MOTOR.....	3-62
	3.10.3 QUENCHING LAMP.....	3-64
	3.10.4 TD SENSOR.....	3-66
	3.10.5 TEST AFTER REPLACING THE PCDU .....	3-67
3.11	PAPER FEED.....	3-68
	3.11.1 PAPER FEED ROLLER, FRICTION PAD .....	3-68
	Notes on Replacing the Friction Pad .....	3-69
	3.11.2 PAPER DUST COLLECTOR.....	3-70
	Notes on Installing the Paper Dust Collector .....	3-71
	3.11.3 REGISTRATION SENSOR .....	3-72
	How to Clean the Registration Sensor.....	3-72
	3.11.4 PAPER END SENSOR.....	3-73
	3.11.5 REGISTRATION CLUTCH, PAPER FEED CLUTCH .....	3-74
	3.11.6 REGISTRATION ROLLER .....	3-75
	Registration Roller (main machine side).....	3-75
	Registration Roller (right cover side).....	3-76
	How to Clean the Registration Roller.....	3-78
3.12	TRANSFER UNIT.....	3-79
	3.12.1 TRANSFER ROLLER UNIT .....	3-79
	3.12.2 NOTES ON INSTALLING THE TRANSFER ROLLER UNIT.....	3-80
	3.12.3 ID SENSOR.....	3-81
	How to Clean the ID Sensor.....	3-82
	3.12.4 PCL (PRE CLEANING LAMP) .....	3-83
	How to Clean the PCL.....	3-83
3.13	FUSING UNIT.....	3-84
	3.13.1 CAUTION DECAL LOCATION .....	3-84
	3.13.2 FUSING UNIT.....	3-84
	Notes on Installing the Fusing Unit .....	3-86
	3.13.3 FUSING THERMISTOR .....	3-86
	3.13.4 FUSING LAMP .....	3-87
	3.13.5 PRESSURE ROLLER AND BUSHINGS.....	3-89
	Notes on Installing the Pressure Roller.....	3-90
	3.13.6 HOT ROLLER.....	3-91
	Applying the grease.....	3-91
	3.13.7 HOT ROLLER STRIPPER PAWLS .....	3-93
	3.13.8 THERMOSTAT .....	3-93

3.14	DUPLEX, PAPER EXIT .....	3-94
3.14.1	DUPLEX UNIT (RIGHT COVER) .....	3-94
3.14.2	PAPER EXIT ROLLER .....	3-96
3.14.3	PAPER EXIT REVERSE SENSOR .....	3-97
3.14.4	PAPER EXIT CLUTCH, REVERSE EXIT CLUTCH.....	3-97
3.14.5	DUPLEX ENTRANCE SENSOR.....	3-99
3.14.6	DUPLEX EXIT SENSOR .....	3-100
3.14.7	DUPLEX ROLLERS .....	3-102
	Duplex Drive Roller .....	3-102
	Duplex Driven Roller .....	3-104
	How to Clean the Duplex Driven Roller and the Duplex Drive Roller.....	3-106
3.14.8	DUPLEX REVERSE CLUTCH .....	3-107
	Notes on Installing the Duplex Reverse Clutch .....	3-108
3.14.9	PAPER EXIT INDICATOR .....	3-109
3.15	BYPASS .....	3-110
3.15.1	BYPASS CLUTCH.....	3-110
3.15.2	BYPASS UNIT .....	3-111
3.15.3	BYPASS PAPER END SENSOR .....	3-112
3.15.4	BYPASS PAPER FEED ROLLER, BYPASS SEPARATION ROLLER .....	3-113
	Notes on Installing the Bypass Separation Roller.....	3-114
3.16	ELECTRICAL COMPONENTS, OTHER ITEMS .....	3-115
3.16.1	CONTROLLER BOX .....	3-115
	Notes on Installing the Controller Box.....	3-116
3.16.2	CONTROLLER BOARD .....	3-117
	Notes on Replacing the Controller Board .....	3-117
3.16.3	BICU (BASE-ENGINE IMAGE CONTROL UNIT).....	3-118
3.16.4	NVRAM.....	3-119
	NVRAM on the Controller Board.....	3-119
	NVRAM (EEPROM) on the BiCU.....	3-122
3.16.5	MAIN POWER SWITCH.....	3-123
3.16.6	PSU (POWER SUPPLY UNIT).....	3-124
3.16.7	HVPS (HIGH-VOLTAGE POWER SUPPLY).....	3-125
3.16.8	FRONT COVER SWITCH .....	3-126
3.16.9	RIGHT COVER OPEN/CLOSE SWITCH.....	3-126
3.16.10	TEMPERATURE/HUMIDITY SENSOR .....	3-127
3.16.11	HDD .....	3-127
3.16.12	MAIN MOTOR.....	3-128
3.16.13	INTAKE FAN .....	3-131
3.16.14	EXHAUST FAN .....	3-132

Notes on Installing the Exhaust Fan .....	3-133
3.16.15 INTERNAL TEMPERATURE SENSOR .....	3-133
3.16.16 DUST FILTER .....	3-134
3.16.17 CLUTCHES.....	3-134
Applying the Grease.....	3-135
3.17 ADJUSTMENT AFTER REPLACEMENT .....	3-139
3.17.1 PRINTING .....	3-139
Registration - Leading Edge/Side-to-Side.....	3-139
Blank Margin.....	3-141
Main Scan Magnification .....	3-143
3.17.2 SCANNING.....	3-143
Registration: Platen Mode.....	3-143
3.17.3 ARDF IMAGE ADJUSTMENT.....	3-145
Registration/Blank Margin .....	3-145
Sub Scan Magnification.....	3-146
Skew Adjustment.....	3-146

## **4. SYSTEM MAINTENANCE..... 4-1**

4.1 SERVICE PROGRAM MODE.....	4-1
4.1.1 ENABLING AND DISABLING SERVICE PROGRAM MODE.....	4-1
Entering SP Mode .....	4-1
Exiting SP Mode .....	4-1
4.1.2 TYPES OF SP MODES.....	4-1
SP Mode Button Summary.....	4-2
Switching Between SP Mode and Copy Mode for Test Printing.....	4-3
Selecting the Program Number.....	4-3
Exiting Service Mode.....	4-4
Service Mode Lock/Unlock.....	4-5
PM Counter/ Firmware Update .....	4-5
4.1.3 REMARKS.....	4-7
Others.....	4-7
4.2 TEST PATTERN PRINTING .....	4-9
4.3 FIRMWARE UPDATE .....	4-11
4.3.1 OVERVIEW .....	4-11
4.3.2 FIRMWARE TYPE.....	4-11
4.3.3 PROCEDURE.....	4-12
Update procedure.....	4-12
4.3.4 ERROR SCREENS DURING UPDATING .....	4-16
4.4 UPDATING JAVAVM .....	4-23
4.4.1 CREATING AN SD CARD FOR UPDATING.....	4-23

Updating Procedure .....	4-23
List of Error Messages .....	4-24
4.5 NVRAM DATA UPLOAD/DOWNLOAD .....	4-27
4.5.1 UPLOADING CONTENT OF NVRAM TO AN SD CARD .....	4-27
4.5.2 DOWNLOADING AN SD CARD TO NVRAM.....	4-28
4.6 UP/SP DATA IMPORT/EXPORT.....	4-29
4.6.1 OVERVIEW .....	4-29
Import/export conditions.....	4-29
4.6.2 UP DATA IMPORT/EXPORT .....	4-29
Data that can be imported and exported.....	4-29
Data that cannot be imported or exported .....	4-30
Exporting Device Information .....	4-30
Importing Device Information .....	4-31
4.6.3 SP DATA IMPORT/EXPORT .....	4-32
Data that can be imported and exported.....	4-32
Exporting Device Information .....	4-32
Importing Device Information .....	4-34
4.6.4 POSSIBLE SOLUTIONS FOR IMPORT/EXPORT PROBLEMS.....	4-35
4.7 ADDRESS BOOK EXPORT/IMPORT .....	4-38
4.7.1 EXPORT .....	4-38
4.7.2 IMPORT.....	4-39
4.7.3 SPECIFICATION .....	4-40
4.8 RFU UPDATING THE FIRMWARE .....	4-41
4.8.1 RFU PERFORMABLE CONDITION .....	4-41
4.9 PACKAGE FIRMWARE UPDATE .....	4-42
4.9.1 OVERVIEW .....	4-42
4.9.2 IMMEDIATE UPDATE .....	4-43
4.9.3 UPDATE AT THE NEXT VISIT (RESERVE) .....	4-46
How to Set the Machine to Download Firmware Later (RESERVE) .....	4-46
How to Check if the Firmware Downloaded with RESERVE.....	4-48
How to Install Firmware Downloaded with RESERVE.....	4-50
4.9.4 UPDATE VIA SD CARD .....	4-53
4.10 CAPTURING THE DEBUG LOGS.....	4-55
4.10.1 OVERVIEW .....	4-55
Security of the Operation Log .....	4-57
4.10.2 RETRIEVING THE DEBUG LOGS .....	4-57
Procedure for Retrieving the Debug Log with SD Card.....	4-57
Procedure for Retrieving the Debug Log via Web Image Monitor.....	4-60
Log File List .....	4-62



<b>5. TROUBLESHOOTING .....</b>	<b>5-1</b>
5.1 SELF-DIAGNOSTIC MODE.....	5-1
5.1.1 SERVICE CALL CODES .....	5-1
Service Call Conditions .....	5-1
5.1.2 SC LOGGING.....	5-2
5.1.3 SC AUTOMATIC REBOOT .....	5-3
5.2 SC1XX.....	5-5
5.2.1 SC101-01 .....	5-5
5.2.2 SC102-00 .....	5-6
5.2.3 SC120-00, SC121-00.....	5-7
5.2.4 SC141-00 .....	5-8
5.2.5 SC142-00 .....	5-9
5.2.6 SC144-00 .....	5-10
5.2.7 SC165-00 .....	5-11
5.3 SC2XX.....	5-12
5.3.1 SC202-00, SC203-00, SC204-00.....	5-12
5.3.2 SC220-00 .....	5-13
5.3.3 SC230-00, SC231-00.....	5-14
5.3.4 SC240-00 .....	5-15
5.3.5 SC270-00 .....	5-16
5.3.6 SC272-01 .....	5-17
5.3.7 SC272-10 .....	5-18
5.4 SC3XX.....	5-19
5.4.1 SC302-00 .....	5-19
5.4.2 SC355-00 .....	5-20
5.4.3 SC360-01 .....	5-21
5.4.4 SC361-01, SC362-01 .....	5-22
5.4.5 SC391-00 .....	5-23
5.4.6 SC392-00 .....	5-25
5.5 SC 4XX.....	5-26
5.5.1 SC440-00 .....	5-26
5.5.2 SC460-00 .....	5-27
5.5.3 SC497-00 .....	5-28
5.5.4 SC498-00 .....	5-28
5.6 SC5XX.....	5-29
5.6.1 SC502-01 .....	5-29
5.6.2 SC502-02 .....	5-30
5.6.3 SC520-00 .....	5-31
5.6.4 SC521-00 .....	5-33

5.6.5	SC534-00 .....	5-34
5.6.6	SC534-01 .....	5-35
5.6.7	SC541-00, 02 .....	5-36
5.6.8	SC542-01, -03, -04, -06.....	5-37
5.6.9	SC543-00, SC544-00.....	5-38
5.6.10	SC545-00, -04 .....	5-39
5.6.11	SC547-01, -02, -03.....	5-40
5.6.12	SC549-00 .....	5-41
5.6.13	SC551-00, -02 .....	5-42
5.6.14	SC552-01, -03, -04, 06.....	5-43
5.6.15	SC553-00, SC554-00.....	5-44
5.6.16	SC557-00 .....	5-45
5.6.17	SC559-00 .....	5-45
5.7	SC6XX (INCLUDING CONTROLLER SERVICE CALLS).....	5-46
5.7.1	SC622-00 .....	5-46
5.7.2	SC632-00, SC633-00, SC634-00, SC635-00 .....	5-47
5.7.3	SC636-01 .....	5-48
5.7.4	SC636-02 .....	5-49
5.7.5	SC637-01, -02 .....	5-49
5.7.6	SC641-00 .....	5-50
5.7.7	SC650-01, -04, -05, -13.....	5-51
5.7.8	SC650-14 .....	5-52
5.7.9	SC651-01, -02 .....	5-52
5.7.10	SC652-00 .....	5-53
5.7.11	SC653-00 .....	5-53
5.7.12	SC669-01 TO -26, -36, -37.....	5-54
5.7.13	SC670-01, -02 .....	5-56
5.7.14	SC672-10 TO -13, -99.....	5-57
5.7.15	SC673-10 .....	5-58
5.7.16	SC681-01, -06, -11, -16, -21, -26, -31, -36.....	5-59
5.7.17	SC682-01, -06, -11, -16, -21, -26, -31, -36.....	5-61
5.7.18	SC687-00 .....	5-63
5.8	SC7XX.....	5-64
5.9	SC8XX.....	5-65
5.9.1	SC816-00 TO -96, -99.....	5-65
5.9.2	SC817-00 .....	5-66
5.9.3	SC818-00 .....	5-66
5.9.4	SC819-00 [0X5032].....	5-67
5.9.5	SC819-00 [0X6261], [0X696E], [0X766D], [554C], OTHERS.....	5-68

5.9.6 SC820-00 [XXXX].....	5-70
5.9.7 SC821-00 [XXXX].....	5-74
5.9.8 SC822-00 [XXXX].....	5-75
5.9.9 SC823-00 [XXXX].....	5-76
5.9.10 SC824-00 [1401] .....	5-77
5.9.11 SC827-00 [0201], [0202] .....	5-78
5.9.12 SC828-00 [0101] .....	5-79
5.9.13 SC829-00 [XXXX].....	5-80
5.9.14 SC833-00 [0F30], [50B1], [50B2].....	5-81
5.9.15 SC834-00 [5101] .....	5-82
5.9.16 SC835-00 [1102], [110C], [1120] .....	5-83
5.9.17 SC838-00 [2701] .....	5-84
5.9.18 SC839-00 [9001] .....	5-84
5.9.19 SC840-00 .....	5-85
5.9.20 SC841-00 .....	5-85
5.9.21 SC842-00, -02 .....	5-86
5.9.22 SC845-01 TO -05 .....	5-87
5.9.23 SC853-00 .....	5-87
5.9.24 SC850-00 .....	5-87
5.9.25 SC854-00 .....	5-88
5.9.26 SC857-00 .....	5-88
5.9.27 SC858-00, -01, -02, -30, -31 .....	5-89
5.9.28 SC859-00, -01, 02, -10.....	5-90
5.9.29 SC860-00 .....	5-91
5.9.30 SC862-00 .....	5-92
5.9.31 SC863-00 .....	5-92
5.9.32 SC863-01, -02 TO -23.....	5-93
5.9.33 SC864-01, -02 TO -23.....	5-94
5.9.34 SC865-00, -01, -02 TO -23, -50 TO -73 .....	5-95
5.9.35 SC866-00 .....	5-96
5.9.36 SC867-00 TO -02 .....	5-96
5.9.37 SC868-00, -02 .....	5-97
5.9.38 SC870-00 TO -60 .....	5-98
5.9.39 SC871-01 .....	5-100
5.9.40 SC872-00 .....	5-100
5.9.41 SC873-00 .....	5-101
5.9.42 SC874-XX.....	5-102
5.9.43 SC875-01, -02 .....	5-103
5.9.44 SC876-00 .....	5-104

5.9.45	SC877-00 .....	5-105
5.9.46	SC878-00, -01, -02, -03.....	5-106
5.9.47	SC881-01 .....	5-107
5.9.48	SC899-00 .....	5-108
5.10	SC9XX.....	5-109
5.10.1	SC900-00 .....	5-109
5.10.2	SC920-02, -04 .....	5-109
5.10.3	SC921-00 .....	5-110
5.10.4	SC925-00, -01 .....	5-110
5.10.5	SC990-00 .....	5-111
5.10.6	SC991-00 .....	5-111
5.10.7	SC992-00 .....	5-112
5.10.8	SC997-00 .....	5-112
5.10.9	SC998-00 .....	5-113
5.11	JAM DETECTION .....	5-114
5.11.1	PAPER JAM DISPLAY .....	5-114
5.11.2	JAM CODES AND DISPLAY CODES .....	5-114
	Jam Code List (Main machine), Cover Open Direction .....	5-115
	Jam Code List (Duplex), Cover Open Direction.....	5-116
	Jam Code List (ARDF) , Cover Open Direction .....	5-117
5.11.3	SENSOR LAYOUT .....	5-118
5.11.4	PAPER SIZE CODES.....	5-119
5.12	OTHER PROBLEMS.....	5-120
5.12.1	HOW TO RE-INSTALL THE OCR UNIT .....	5-120
5.12.2	DECREASING THE FUSING PRESSURE.....	5-121
	Pressure Mechanism.....	5-121
	Decreasing the Pressure.....	5-122
5.13	FUSE LOCATION.....	5-124

## **6. DETAILED DESCRIPTIONS ..... 6-1**

6.1	PRODUCT OVERVIEW .....	6-1
6.1.1	COMPONENT LAYOUT .....	6-1
6.1.2	PAPER PATH.....	6-2
6.1.3	DRIVE LAYOUT .....	6-3
6.1.4	PARTS LAYOUT.....	6-5
	Scanner Unit.....	6-5
	Duplex/Bypass Unit .....	6-6
	Laser Unit, PCDU .....	6-7
	Toner Supply Unit .....	6-8
	Fusing Unit, Paper Exit Section .....	6-9

Paper Feed Unit .....	6-10
Drive Unit.....	6-11
Electrical Components 1 .....	6-12
Electrical Components 2 .....	6-13
6.2 SCANNER UNIT .....	6-14
6.2.1 OVERVIEW .....	6-14
6.2.2 MECHANISM.....	6-15
Original Width Detection.....	6-15
6.2.3 RELATED SPS .....	6-17
6.3 ARDF.....	6-18
6.3.1 OVERVIEW .....	6-18
Layout.....	6-18
6.3.2 DETAILED DESCRIPTION .....	6-20
ARDF Drives.....	6-20
Original Set Detection .....	6-20
Original Transport (Single-sided Scanning) .....	6-21
Original Transport (Duplex Scanning).....	6-22
6.4 IMAGE PROCESSING .....	6-23
6.4.1 BLOCK DIAGRAM.....	6-23
6.4.2 OVERVIEW .....	6-23
CIS Unit .....	6-23
BiCU .....	6-24
6.4.3 RELATED SPS .....	6-25
6.5 LASER EXPOSURE .....	6-26
6.5.1 OVERVIEW .....	6-26
6.5.2 AUTO POWER CONTROL (APC) .....	6-27
6.5.3 LD SAFETY SWITCH.....	6-28
6.6 PCU.....	6-29
6.6.1 OVERVIEW .....	6-29
6.6.2 MECHANISM.....	6-30
Drum Drive Mechanism.....	6-30
Drum Charge.....	6-31
Charging Bias Correction (Environmental Correction).....	6-32
ID Sensor.....	6-33
Cleaning the Charge Roller.....	6-33
Drum Cleaning .....	6-34
Toner Recycling.....	6-35
6.7 DEVELOPMENT AND TONER SUPPLY .....	6-36
6.7.1 OVERVIEW .....	6-36

6.7.2	MECHANISM.....	6-37
	Drive .....	6-37
	Developer Mixing.....	6-37
	Development Bias .....	6-38
	Toner Supply.....	6-39
	Toner Density Control.....	6-41
	Toner Near End/End Detection and Recovery .....	6-43
6.7.3	RELATED SPS .....	6-45
6.8	IMAGE TRANSFER AND PAPER SEPARATION.....	6-46
6.8.1	OVERVIEW .....	6-46
6.8.2	MECHANISM.....	6-47
	Image Transfer and Paper Separation.....	6-47
	Drive .....	6-47
6.9	IMAGE FUSING AND PAPER EXIT .....	6-48
6.9.1	OVERVIEW .....	6-48
6.9.2	MECHANISM.....	6-49
	Fusing Unit Drive.....	6-49
	Fusing Entrance Guide Shift .....	6-50
	Pressure Roller.....	6-51
	Fusing Temperature Control: Fusing Thermistors.....	6-51
	Overheat Protection/Thermostat .....	6-55
	Fusing lamp.....	6-55
	CPM Reduction .....	6-56
6.9.3	RELATED SPS .....	6-56
6.10	PAPER FEED .....	6-57
6.10.1	OVERVIEW .....	6-57
6.10.2	MECHANISM.....	6-58
	Paper Feed Drive Mechanism.....	6-58
	Paper Feed and Separation Mechanism .....	6-59
	Paper Lift Mechanism.....	6-60
	Paper End Detection .....	6-61
6.10.3	BYPASS TRAY .....	6-62
	Bypass Tray Paper Registration.....	6-63
6.10.4	DUPLEX .....	6-64
	Overview.....	6-64
	Interleaving .....	6-65
6.11	VENTILATION .....	6-67
6.11.1	OVERVIEW .....	6-67
	Exhaust.....	6-68

	Intake.....	6-69
6.12	OPERATION PANEL.....	6-70
6.13	ELECTRICAL PARTS.....	6-71
	6.13.1 BLOCK DIAGRAM.....	6-71
	6.13.2 BOARD OUTLINE .....	6-72
6.14	OTHER FEATURES.....	6-73
	6.14.1 SILENT MECHANISM.....	6-73
	6.14.2 TRANSITION FOR POWER SAVING.....	6-74
	6.14.3 DUTY CONTROL .....	6-77
	High Productivity Mode .....	6-79
	6.14.4 OPERATION IN LOW-VOLTAGE MODE .....	6-81











# READ THIS FIRST

## Symbols, Abbreviations and Trademarks

This manual uses several symbols and abbreviations. The meaning of those symbols and abbreviations are as follows:

	Clip ring
	Screw
	Connector
	Clamp
	E-ring
	Spring
	Flat Flexible Cable
SEF	Short Edge Feed [A]
LEF	Long Edge Feed [B]
K	Black
C	Cyan
M	Magenta
Y	Yellow
B/W, BW	Black and White
FC	Full color

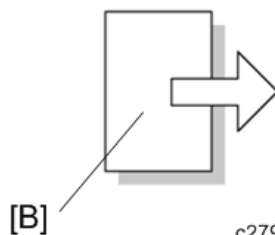
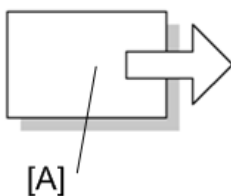

## **Trademarks**

Microsoft<sup>®</sup>, Windows<sup>®</sup>, and MS-DOS<sup>®</sup> are registered trademarks of Microsoft Corporation in the United States and /or other countries.

PostScript<sup>®</sup> is a registered trademark of Adobe Systems, Incorporated.

PCL<sup>®</sup> is a registered trademark of Hewlett-Packard Company.

Ethernet<sup>®</sup> is a registered trademark of Xerox Corporation.

PowerPC<sup>®</sup> is a registered trademark of International Business Machines Corporation.

Other product names used herein are for identification purposes only and may be trademarks of their respective companies. We disclaim any and all rights involved with those marks.

# PRODUCT INFORMATION

REVISION HISTORY		
Page	Date	Added/Updated/New
		None



# 1. PRODUCT INFORMATION

## 1.1 MACHINE CODES AND PERIPHERALS CONFIGURATION

### 1.1.1 SYSTEM CONFIGURATION AND OPTIONS

#### *Main Machine and Peripherals*

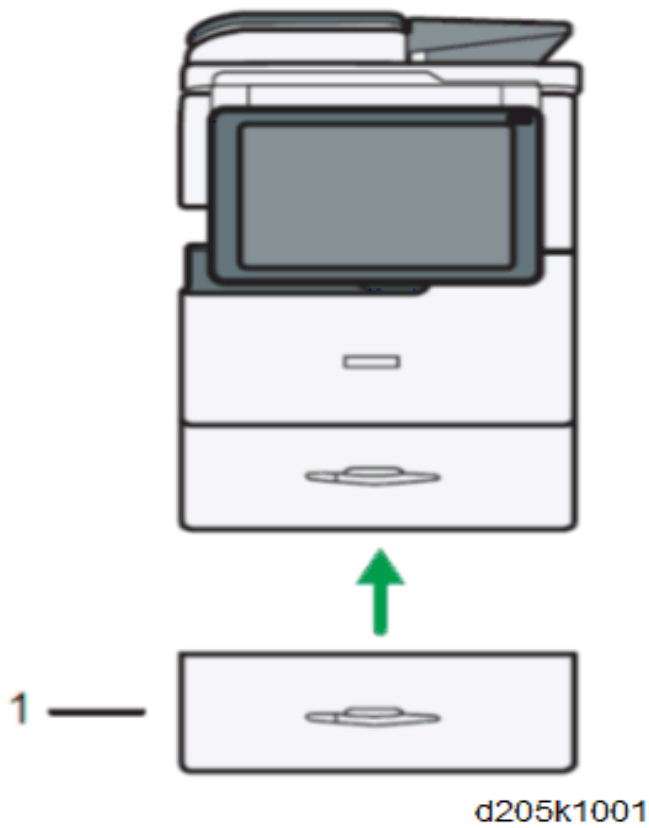

## Machine Codes and Peripherals Configuration

No.	Item	Machine Code	Main Destination				
			NA	EU	AA	TWN	CHN
-	MP 305 <sup>+</sup> SP	D259-27	-	✓	-	-	-
		D259-29	-	-	✓	-	-
		D259-21	-	-	-	-	✓
	MP 305 <sup>+</sup> SPF	D259-57	✓	-	-	-	-
		D259-67	-	✓	-	-	-
		D259-69	-	-	✓	-	-
		D259-19	-	-	-	✓	-
1	Paper Feed Unit PB1090	D794-17	✓	✓	✓	✓	-
		D794-21	-	-	-	-	✓

## Controller Options

Item	Machine Code	Main Destination				
		NA	EU	AA	TWN	CHN
Bluetooth Interface Unit Type D	D566-01	✓	✓	✓	-	-
XPS Direct Print Option Type M15	D3B4-07	✓	-	-	-	-
	D3B4-08	-	✓	-	-	-
	D3B4-09	-	-	✓	✓	✓
OCR Unit Type M13	D3AC-23	✓	-	-	-	-
	D3AC-24	-	✓	-	-	-
	D3AC-25	-	-	✓	✓	✓
Data Overwrite Security Unit Type I	D362-12	✓	✓	✓	-	-
Copy Data Security Unit Type G	D640-41	✓	✓	✓	✓	✓

Item	Machine Code	Main Destination				
		NA	EU	AA	TWN	CHN
Fax Option Type M15	D3B3-02	-	✓	-	-	-
	D3B3-03	-	-	✓	-	-
	D3B3-05	-	-	-	-	✓
Fax Connection Unit Type M15	D3B4-11	✓	-	-	-	-
	D3B4-12	-	✓	-	-	-
	D3B4-13	-	-	✓	✓	✓
NFC Card Reader Type M15	D3B4-31	✓	✓	✓	✓	✓
RICOH e-sharing Box	D668-01	✓	-	-	-	-
	D668-02	-	✓	-	-	-
	D668-03	-	-	✓	-	-
Optional Counter Interface Unit Type M12	B870-21	✓	✓	✓	✓	✓
Enhanced Security HDD Option Type M10	D792-09	✓	✓	-	-	-

## 1.2 INSTALLATION

### 1.3 INSTALLATION REQUIREMENTS

**Note**

- Some illustrations may differ from the actual machine.

#### 1.3.1 ENVIRONMENT

–Temperature and Humidity Chart–

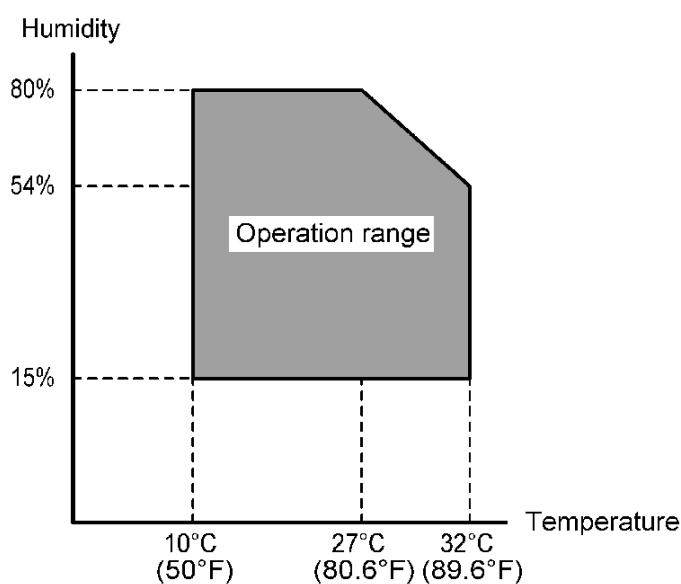

▪ Temperature Range:	10 - 32°C (50 - 89.6°F)
▪ Humidity Range:	15% to 80% RH
▪ Ambient Illumination:	Less than 1,500 lux (do not expose to direct sunlight)
▪ Ventilation:	3 times/hr/person or more
▪ Ambient Dust:	Less than 0.075 mg/m <sup>3</sup> (2.0 x 10 <sup>-6</sup> oz/yd <sup>3</sup> )
▪ Avoid areas exposed to sudden temperature changes:	<ol style="list-style-type: none"> <li>1) Areas directly exposed to cool air from an air conditioner.</li> <li>2) Areas directly exposed to heat from a heater.</li> </ol>
▪ Do not place the machine in areas where it can get exposed to corrosive gases.	
▪ Do not install the machine at any location over 2,000 m (6,500 ft.) above sea level.	



- Place the machine on a strong and level base. (Inclination on any side should be no more than 5 mm.)
- Do not place the machine where it is subjected to strong vibrations.

### 1.3.2 MACHINE LEVEL

Front to back:	Within 5 mm (0.2") of level
Right to left:	Within 5 mm (0.2") of level

### 1.3.3 MINIMUM SPACE REQUIREMENTS

Place the machine near the power source, providing clearance as shown:

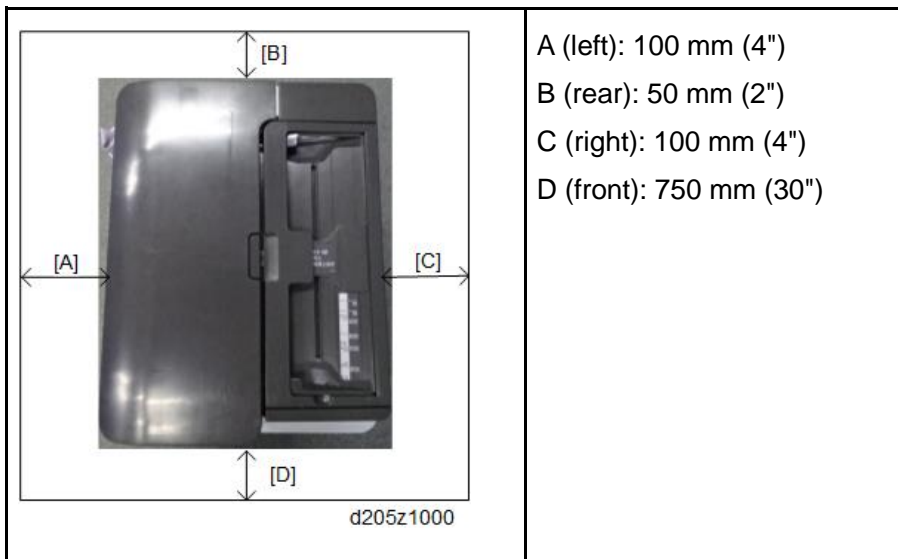

The recommended 750 mm (30") front space is sufficient to allow the paper tray to be pulled out. Additional front space is required to allow operators to stand in front of the machine.

### 1.3.4 POWER REQUIREMENTS

**⚠ CAUTION**

- Make sure that the wall outlet is near the machine and easily accessible. After completing installation, make sure the plug fits firmly into the outlet.
- Avoid multi-wiring.
- Be sure to ground the machine.

**Input voltage:**

North America	120 - 127V 60Hz 12A
Europe, Asia, China	220V - 240V 50/60Hz 8A
Taiwan	110V 60Hz 13A

## 1.4 MAIN MACHINE INSTALLATION

### 1.4.1 IMPORTANT NOTICE ON SECURITY ISSUES

In order to increase the security of the MFP, and to ensure that the customer sets the administrator password, an administrator set/change prompt screen appears at the first power-up.

#### Overview

- The following Program/Change Administrator screen appears at the first power-up.

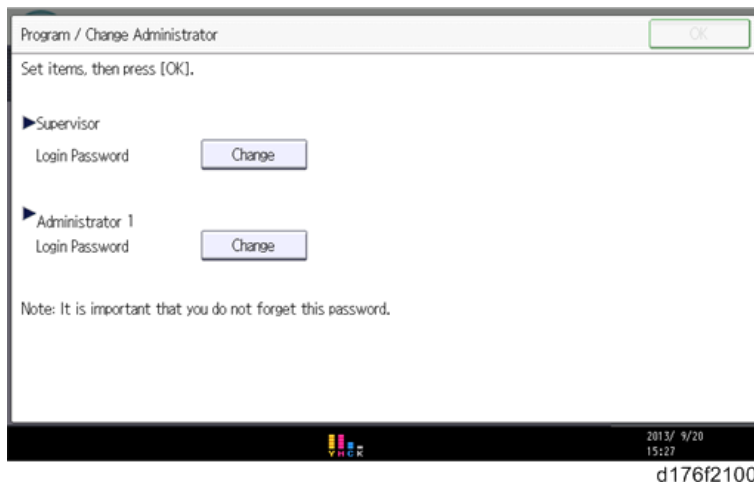

- When the customers set the administrator/supervisor login password, the display disappears and the home screen will appear. However, the customers can make this screen disappear with the following procedure if there is no need to set the password.
  1. **On the Program/Change Administrator screen, press [Change] next to Supervisor and then press [OK] without inputting any password.**
  2. **Press [OK] again when the Confirm password screen shows up.**
  3. **For Administrator 1, do the same procedure as steps 1 and 2.**
  4. **Press [OK], then the home screen appears.**
    - SP5-755-002 allows you to skip this screen temporarily and continue the installation procedure without setting an administrator password. However, the Program/Change Administrator screen appears every time when turning OFF then ON the main power, if the password is not set.

## Password Setting Procedure

### Note

- For more details about this security issue, see “Notes on Using Multi-Function Printers Safely” supplied with the MFP.

### CAUTION

- When Supervisor / Administrator 1-4 passwords are configured via network, the “Change Supervisor login password” window will not display.
- The passwords for Supervisor or Administrator 1 to 4 can be set via “System Settings”. But the Program/Change Administrator screen appears every time when the main power is turned ON if the passwords are input this way. So we recommend the customers to set the passwords via network or the Program/Change Administrator screen.

1. Install the MFP.
2. Turn ON the main power.
3. Change the Supervisor login password.

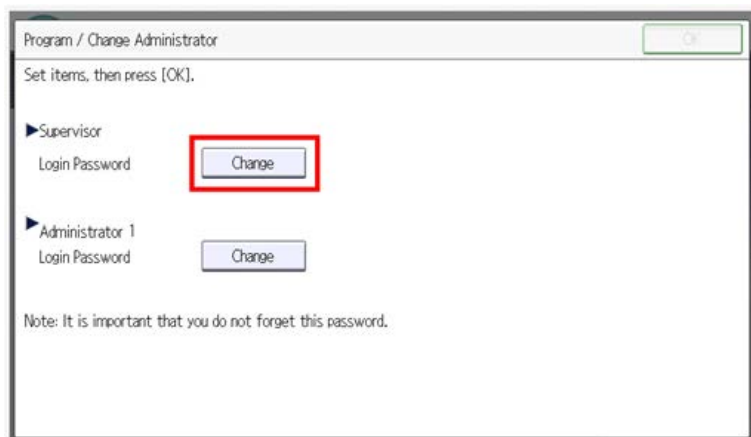

d176f2101

4. Enter the password.

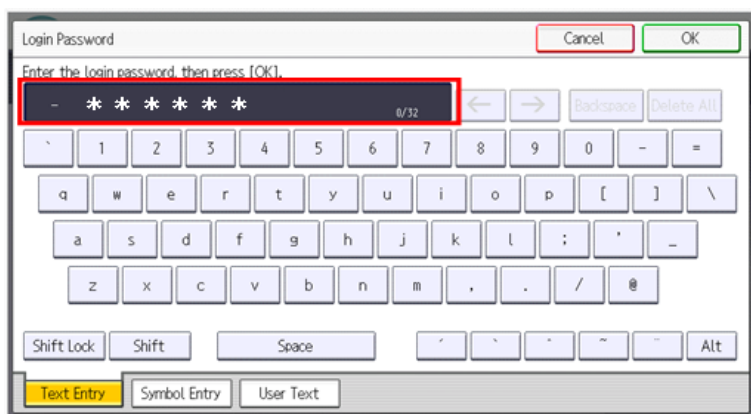

d176f2102

5. Press [OK].



d176f2103

## 6. Confirm the Password.

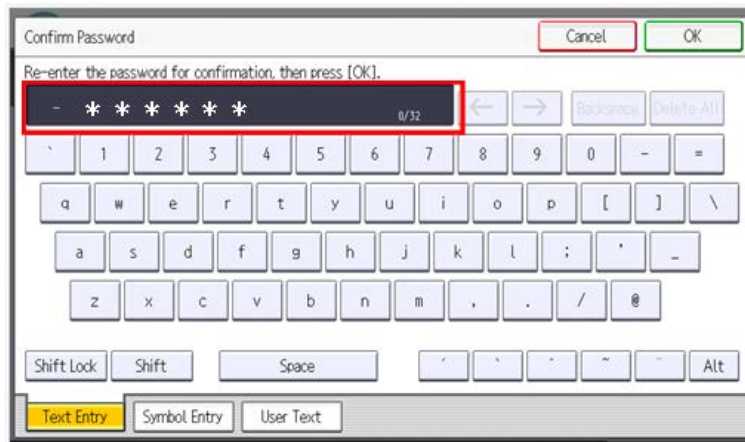

d176f2104

## 7. Press [OK].



d176f2105

## 8. Change the Administrator 1 login password.

## Main Machine Installation

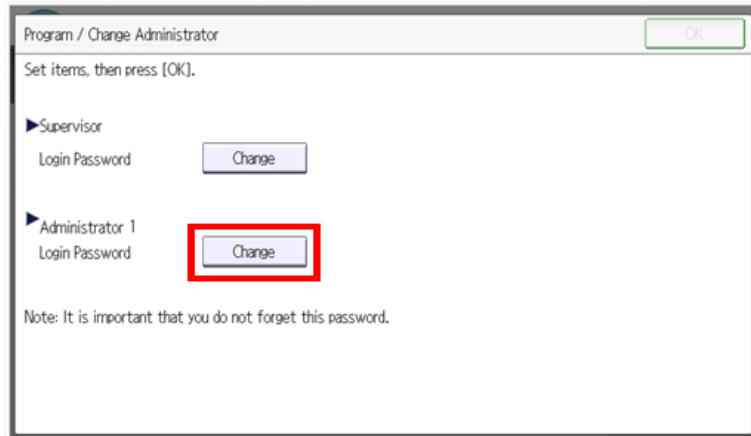

d176f2106

### 9. Enter the password.

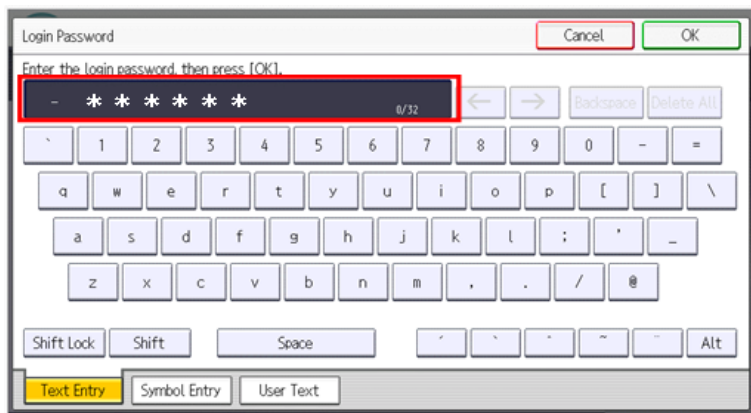

d176f2102

### 10. Press [OK].



d176f2103

### 11. Confirm the password.

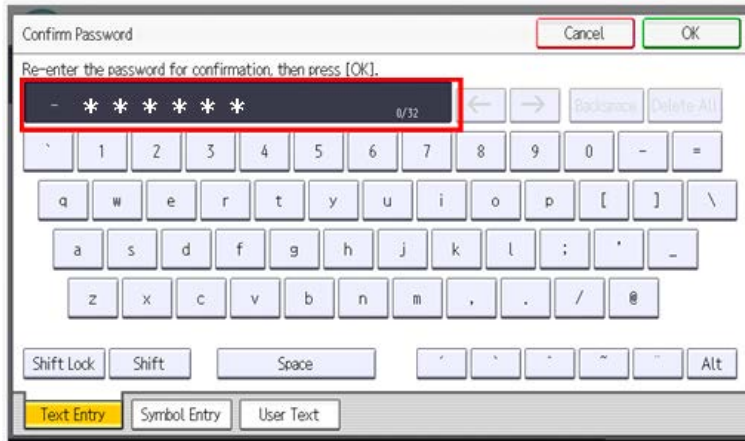

d176f2104

**12. Press [OK].**

d176f2105

**13. Turn OFF then ON the main power.**

## 1.4.2 ACCESSORY CHECK

Check the quantity and condition of the accessories in the box against the following list:

No.	Item	Q'ty	Main Destination (Model)						
			TWN (SPF)	CH (SP)	EU (SP)	AA (SP)	NA (SPF)	EU (SPF)	AA (SPF)
1	Power plug (For 125 V or 250 V)	1	✓	✓	✓	✓	✓	✓	✓
2	Decal	3	✓	✓	✓	✓	✓	✓	✓
3	Brand plate	2	-	-	✓	✓	✓	✓	✓
4	NFC tag	1	✓	✓	✓	✓	✓	✓	✓
5	Modular code with Ferrite core	1	-	-	-	-	✓	-	-
6	Ferrite core	1	✓	-	-	-	-	✓	✓
-	Operating Instruction Set	1	✓	✓	✓	✓	✓	✓	✓
-	EMC address	1	-	✓	-	-	-	✓	-
-	Guarantee sheet	1	-	✓	-	-	-	-	-
-	Caution (FCC)	1	-	-	-	-	✓	-	-
-	Caution (Canada)	1	-	-	-	-	✓	-	-
-	Caution (CE/CH)	1	-	-	✓	-	-	✓	-
-	Safety Information	1	-	-	✓	-	-	✓	-

✓: Included; -: Not included





d259z2100

**Note**

- For NA, modular code and ferrite core is bound in the factory.

### 1.4.3 INSTALLATION PROCEDURE

1. **Unpack the machine and remove all the wrapping.**
2. **Remove all filament tapes and retainers from the machine.**
3. **Open the front cover and right cover.**
4. **Remove the small cover [B] and the PCDU [A].**

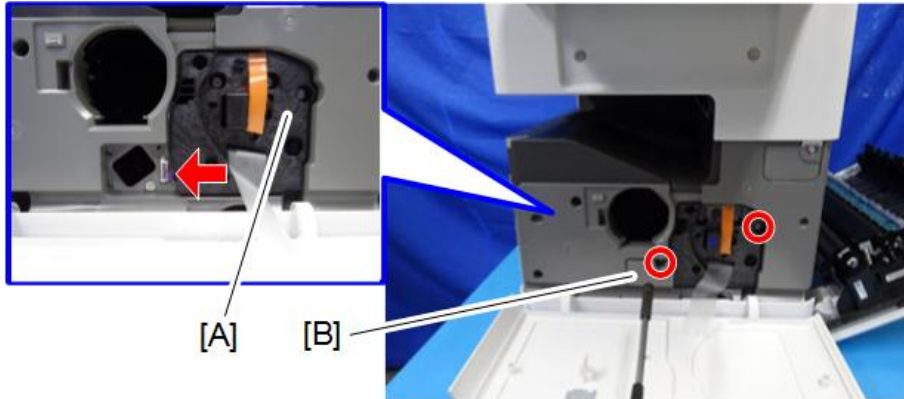

 x2  x1

d205z5044

#### Note

- When taking out the PCDU, hold the lower center and the opposite side of the drum as shown below. Otherwise, the drum may be damaged.



d205z2119

5. **Remove the development unit protection sheet [A].**

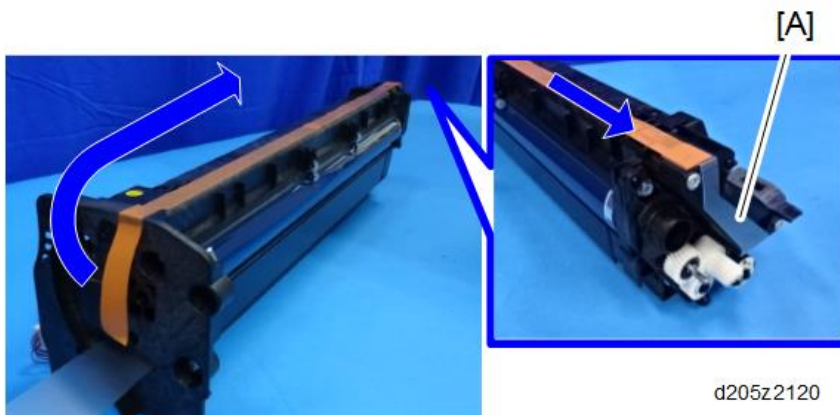

d205z2120

**Note**

- Do not touch the grease applied to the gears on the PCDU.

- Attach the PCDU to the machine.
- Pull out the heat sealing sheet [A] horizontally.

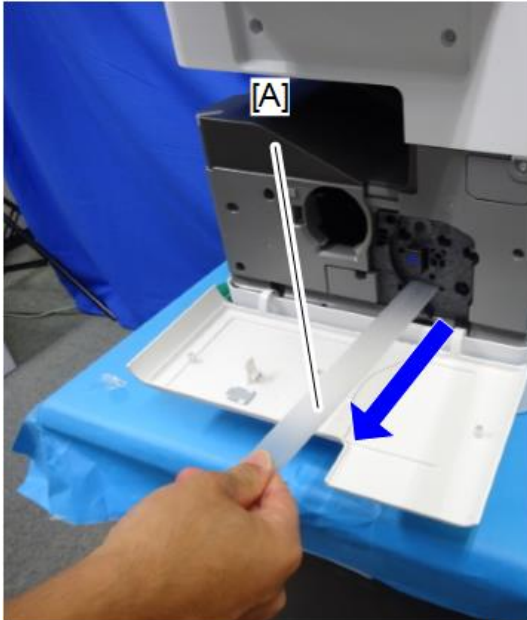

d205z2140

- Close the right cover.
- Shake the toner bottle up and down several times with the cap on top.
- Make sure that the PCDU is securely installed in the machine.

**CAUTION**

- If the toner bottle is installed in the machine without a PCDU, toner scatters due to internal pressure.

- Remove the toner bottle protection cap and install the toner bottle in the machine.
- Close the front cover.
- Turn ON the main power.

**Note**

- The initial toner supply starts automatically. A beep sound is emitted when it is finished.

- Attach the following decals on the ARDF.

## Main Machine Installation



### 15. Attach the decal to the main paper feed tray.

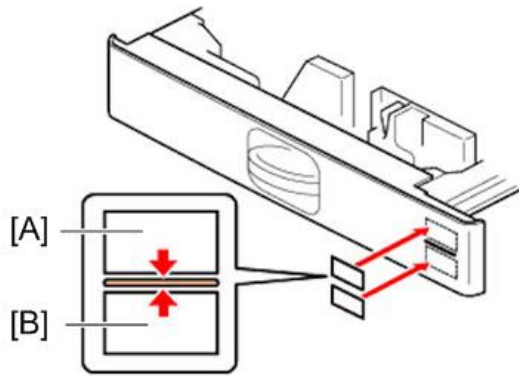

d1462230

[A]: Tray number decal

[B]: Paper size decal

## 1.4.4 CHECK IMAGE QUALITY / SETTINGS

### *Loading Paper*

#### Preparation

- When there are other options to be installed, install according to the procedure for each.
1. **Check that the operation panel shows the following message.**  
"Please supply the tray with paper."
  2. **Pull out the paper feed tray slowly until it stops.**
  3. **While pressing the release lever, adjust the side fence to the paper size to be set.**
  4. **Set the end fence.**
  5. **Square the paper and load it print side up.**

#### Note

- The paper size is basically detected automatically.

### *Checking the copy image with the test chart*

Check the copy image with test charts such as the S5S Test Chart.

#### Note

- If the toner density printed on the page is unstable, copy some more pages.

## 1.4.5 MOVING THE MACHINE

This section shows you how to manually move the machine from one floor to another floor. See the section "Transporting the Machine" if you have to pack the machine and move it a longer distance.

- Turn OFF the main power and pull out the plug.
- Close all the covers and trays.
- Keep the machine horizontal and move it slowly. Tipping and excess vibrations may damage the machine.
- Follow the instruction below when you lift the machine up or down:

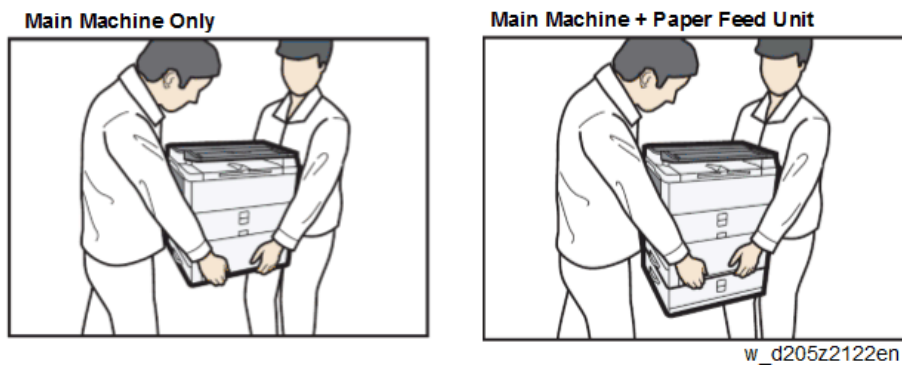

## 1.4.6 TRANSPORTING THE MACHINE

1. Execute SP4-806-001 (\*SSP) to move the scanner carriage from the home position. This prevents dust from falling into the machine during transportation.
2. Remove the toner cartridges. This prevents toner leak, which is caused by vibration during transport.
3. Make sure there is no paper left in the paper trays. Then fix down the bottom plates with a sheet of paper and tape.
4. Take out the scanner stay from inside the front cover and install the scanner stay.
5. Do one of the following step:
  - Attach shipping tape to the covers and doors.
  - Shrink-wrap the machine tightly.

## 1.5 PAPER FEED UNIT PB1090

### Preparation

- If dehumidification heater for optional paper feed tray is used simultaneously, install the dehumidification heater for optional paper feed tray before installing the paper feed unit PB1090. (page 1-25)

### 1.5.1 ACCESSORY CHECK

Check the quantity and condition of the accessories in the box against the following list:

No.	Description	Q'ty
1	Bracket	1
2	Edge Saddle	2
3	Screw	4
4	Decal	1
-	EMC Address	1
-	Rating Name Plate	1

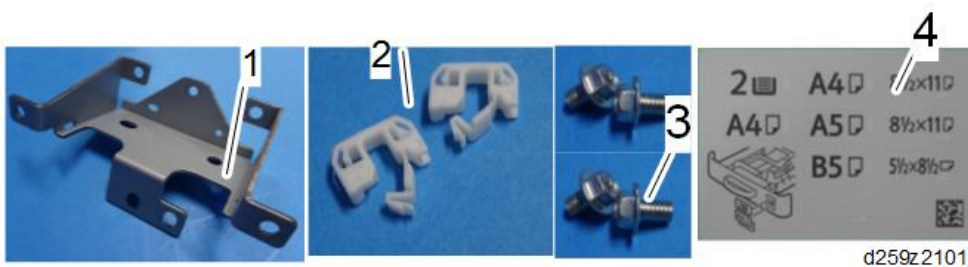



## 1.5.2 INSTALLATION PROCEDURE

### ⚠ CAUTION

- Turn OFF the main power, and unplug the machine power cord before starting the following procedure.
- You need two or more persons to lift the main machine. The main machine is highly unstable when it is lifted by one person, and may cause injury or property damage.
- Be sure to hold the specified positions when lifting the machine.

#### 1. Remove the T-shaped cover [A].



#### 2. Remove the screws of the rear cover [A].

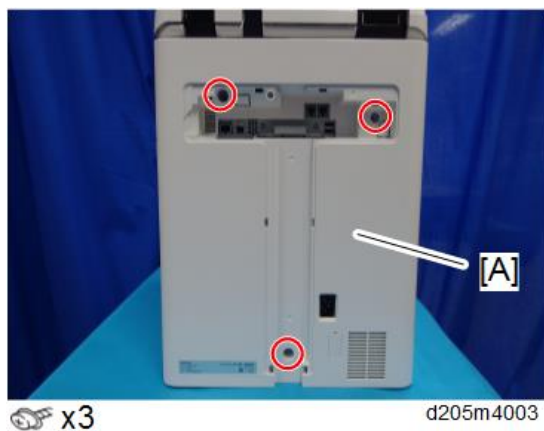

#### 3. Open the right cover.

#### 4. Remove the rear cover [A]. (tab x 2)



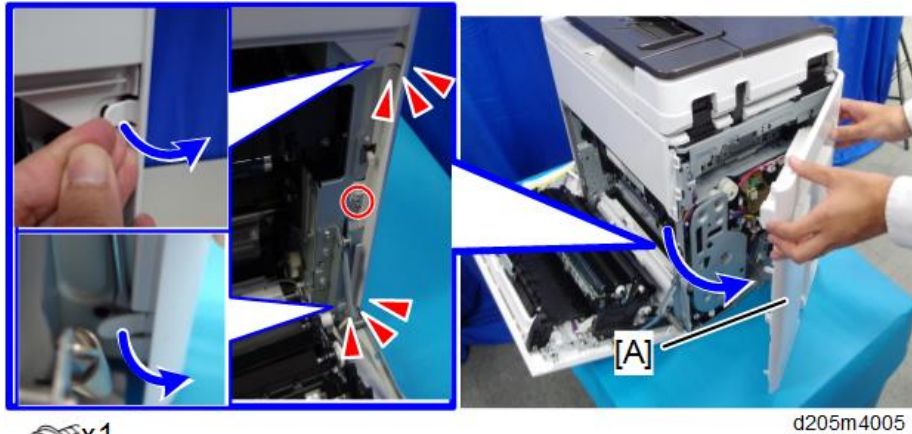

🔑 x1

⬇️ **Note**

- Be careful not to damage the tabs at the rear of the left cover when removing or installing the rear cover.

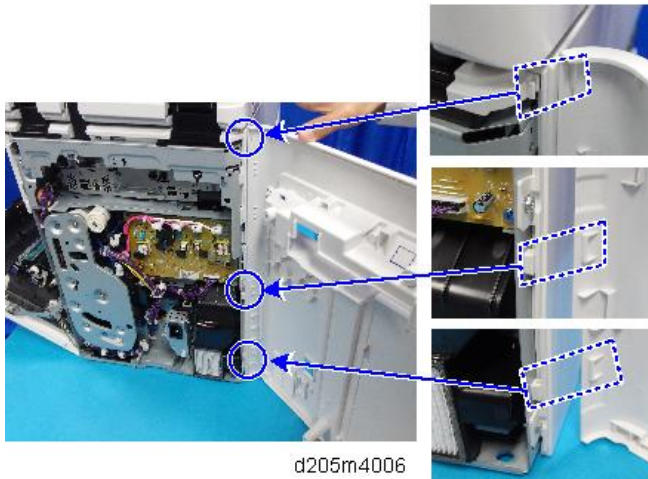

5. Remove the orange tapes retaining the paper feed unit.
6. Remove the screw covers [A], and then remove the screws securing the rear cover [B].

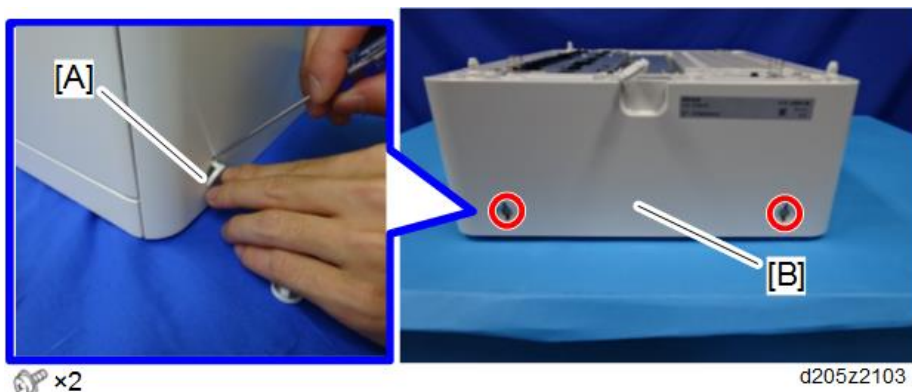

🔑 x2

7. Remove the special tool [A].

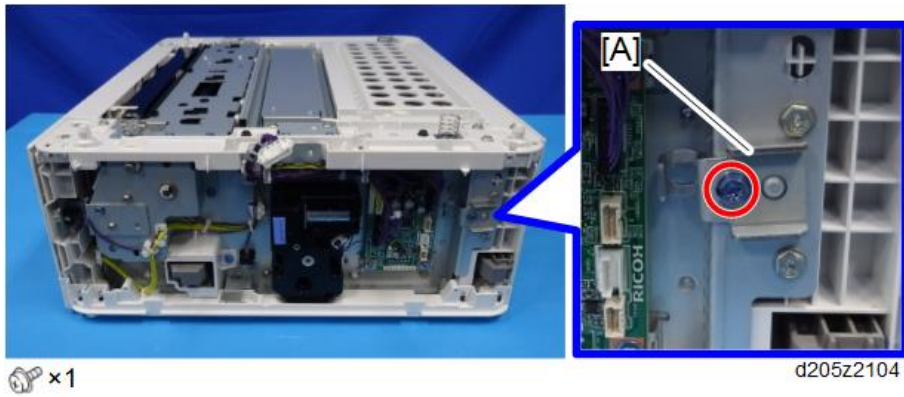

8. Set the main machine on the optional paper feed tray.

9. Remove the bracket [A].

⬇ Note

- Discard the bracket that was just removed.

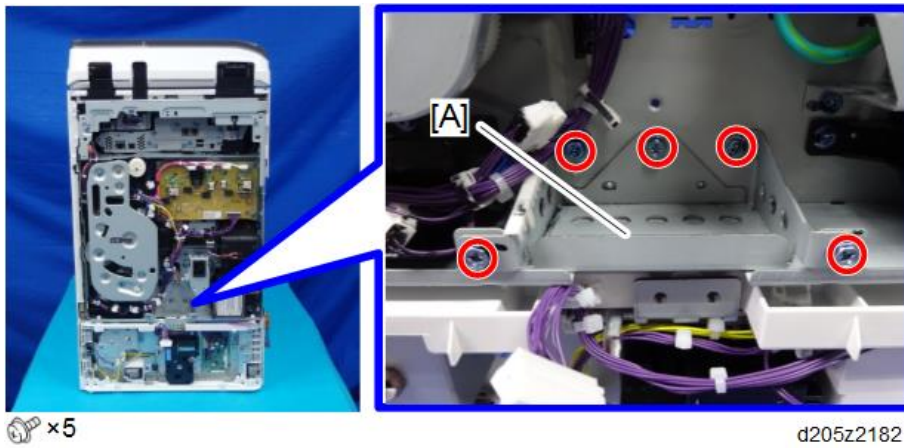

10. Remove the protector [A] from the bracket removed in step 9, and attach it to the bracket packed with this option.

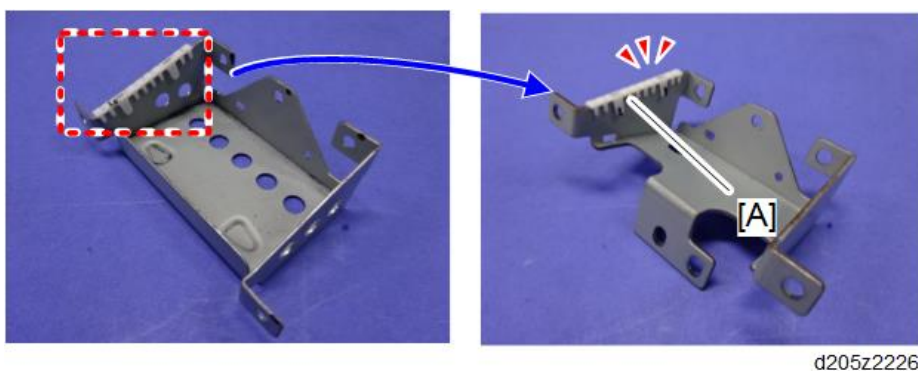

11. Attach the edge saddles [A] packed with this option.

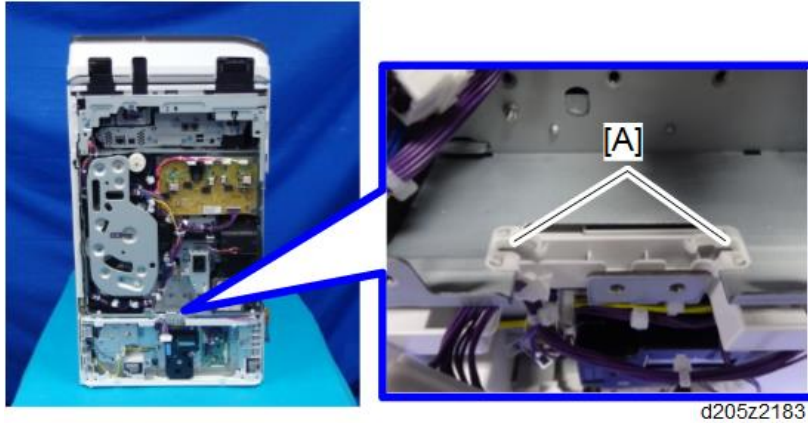

**12. Do the following:**

1. Attach the joint bracket [A] packed with this option.
2. Route the harness [B] through the left edge saddle installed in step 11.

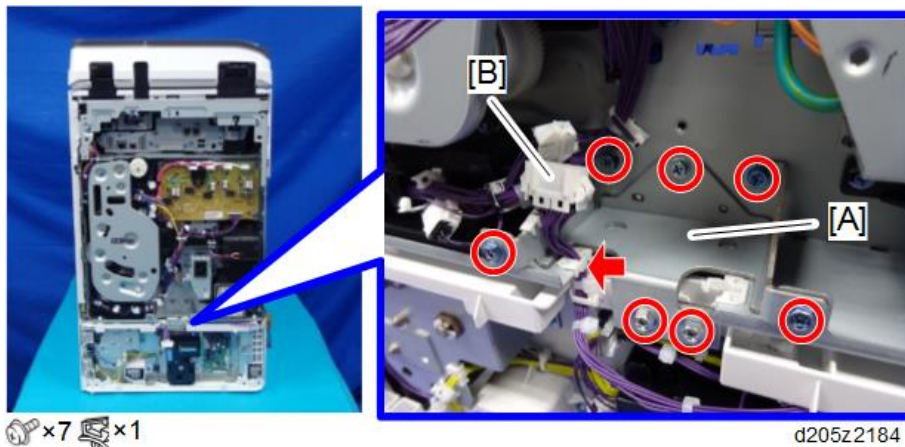

🔧 x7 📦 x1

d205z2184

**13. Connect the connectors ([A] and [B]) at the rear of the machine.**

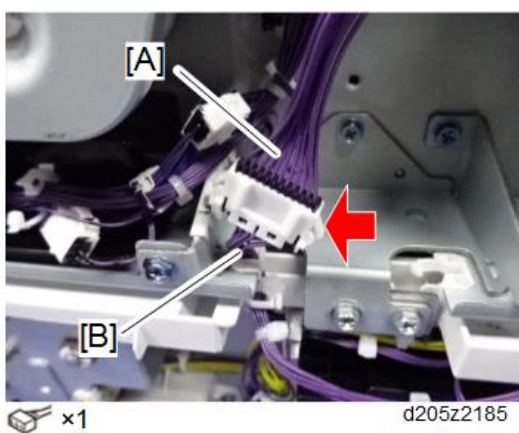

📦 x1

d205z2185

14. Remove the main paper feed tray.
15. Tighten the optional paper feed tray to the main machine using the special tool (removed in step 7).

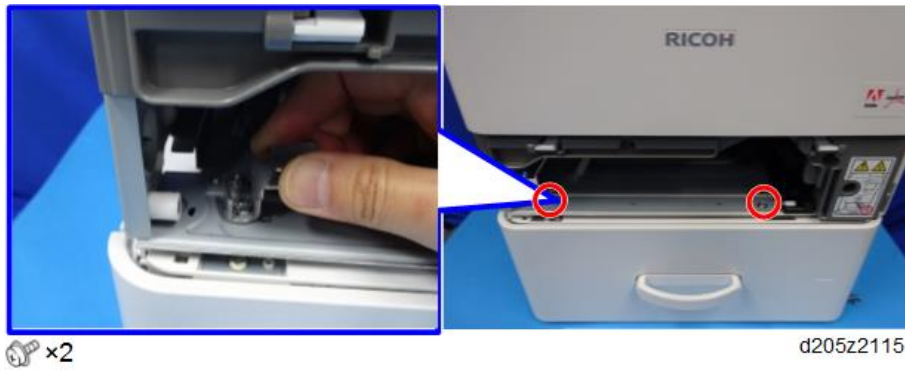

16. Reattach the special tool to the storage position (see step 7).

17. Reassemble the machine.

18. Attach the decals as shown below:

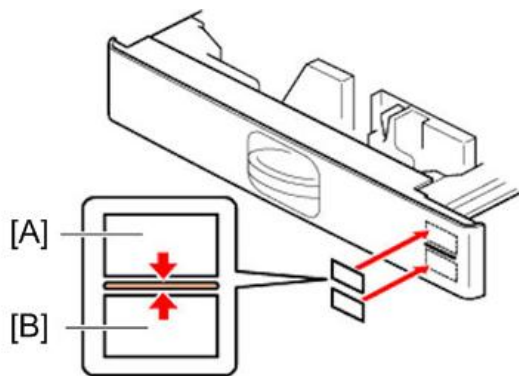

d1462230

[A]: Tray number decal

[B]: Paper size decal

**Note**

- The tray number decal and paper size decal are packaged together with the machine.



## 1.6 DEHUMIDIFICATION HEATERS

### ↓ Note

- **There are two dehumidification heaters for MP 305<sup>+</sup>. If both two dehumidification heaters are used simultaneously, creases can be made on sheets in the trays. See the following basic idea to prevent this:**
  - The dehumidification heater for **optional** paper feed tray should only be installed if the machine has an optional paper feed unit installed. The dehumidification heater for main paper feed tray should not be installed in this case.
  - The dehumidification heater for **main** paper feed tray should only be installed if the machine has no optional paper feed unit installed.

### 1.6.1 DEHUMIDIFICATION HEATER FOR MAIN PAPER FEED TRAY

#### *Accessory Check*

No.	Description	Q'ty	Note
1	Heater with bracket	1	
2	DHB	1	
3	Tapping screw 3x6	4	
4	Clamp	2	
5	Screw M4x10	1	
6	Bracket	1	DHB base
7	Harness	1	Main paper feed tray
8	Harness (short)	1	DHB/PSU
9	Harness (long)	1	DHB/PSU
-	Decal	1	

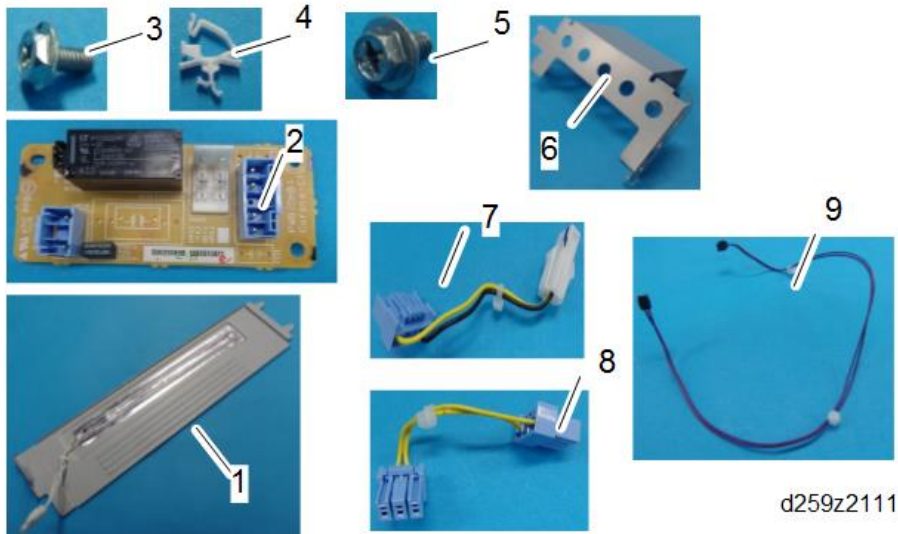

d259z2111

**Installation Procedure**

**⚠ CAUTION**

- You need two or more persons to lift the main machine. The main machine is highly unstable when it is lifted by one person, and may cause injury or property damage.
- Be sure to hold the specified positions when lifting the machine.

**1. Assemble the DHB, harnesses, and bracket as shown below.**

The numbers in the following picture represents the number in the accessory list.

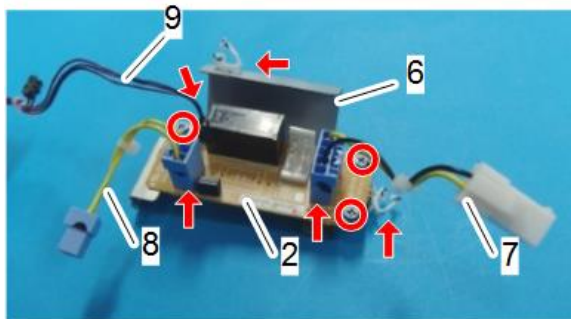

⚙ x3 📏 x3 📦 x2 d259z2112

**2. Remove the T-shaped cover [A]**



d205m4002

**3. Remove the screws from the rear cover [A].**

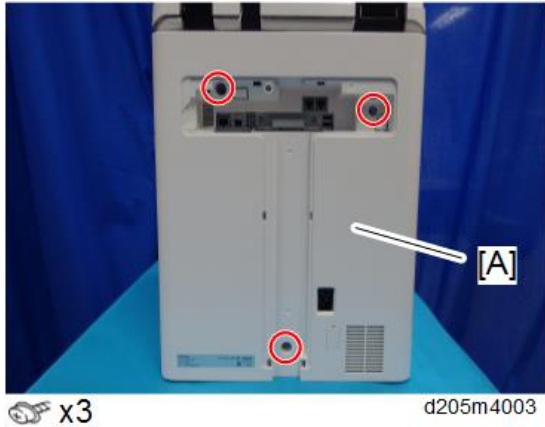

4. Open the right cover.
5. Remove the rear cover [A].



**Note**

- Be careful not to damage the tabs at the rear of the left cover when removing or installing the rear cover.

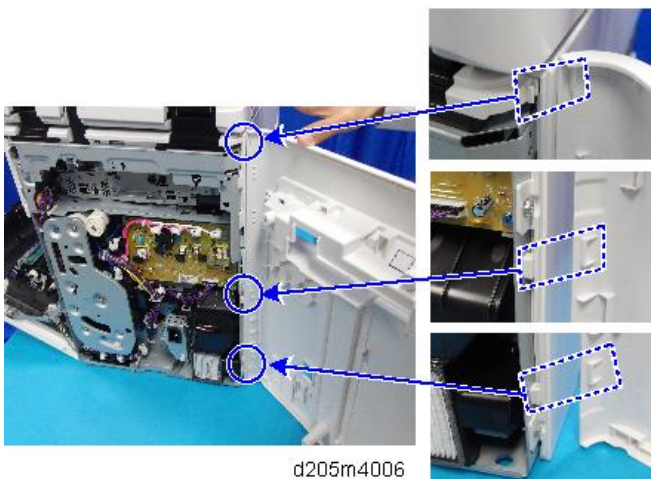

6. Pull out the paper feed tray.
7. Open the front cover.
8. Remove the left lower cover [A].

## Dehumidification Heaters

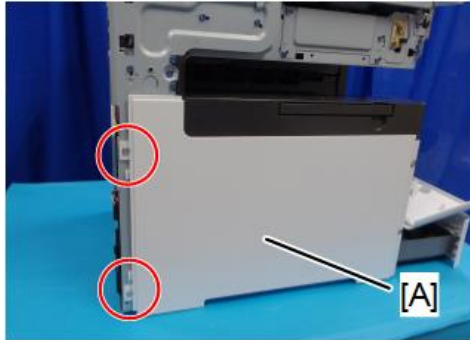

🔑 x2

d205m4014

### ⬇️ Note

- To remove the left lower cover [A], slide it to the rear.

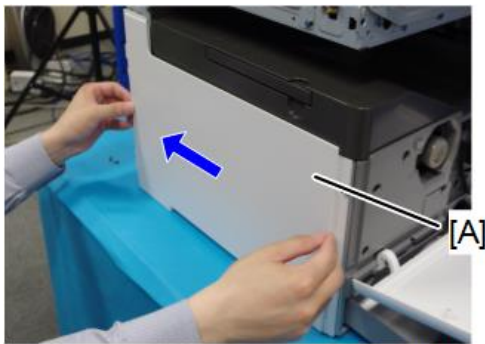

d205m4015

- Be careful not to damage the positioning boss [B] and tabs.

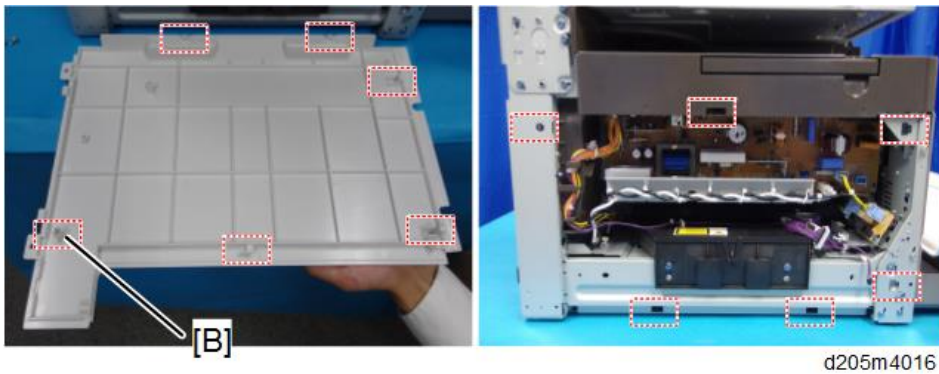

d205m4016

9. Insert the tip [A] of the dehumidification heater for main paper feed tray into the slit [B] in the back of the main paper feed tray.



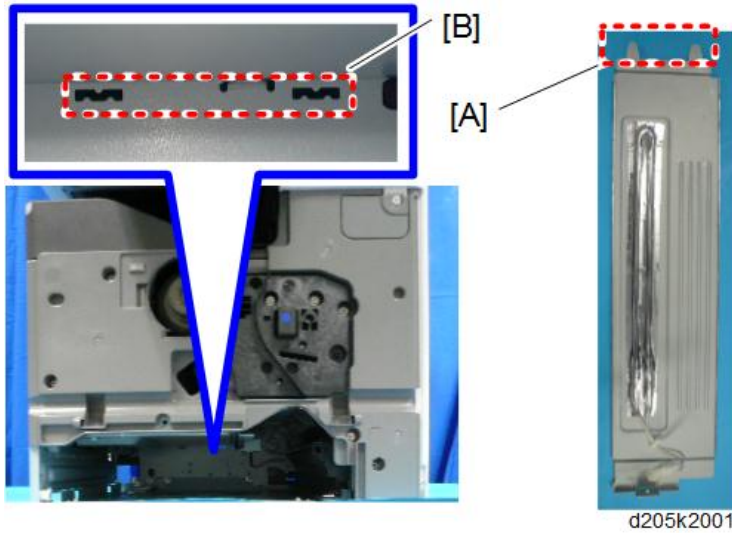

10. Pass the connector [A] of the dehumidification heater for main paper feed tray through the hole [B] in the upper part of the main paper feed tray.

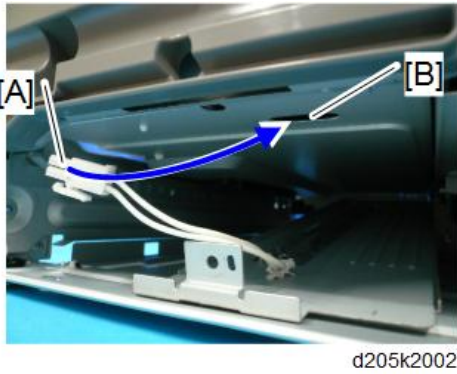

11. Set the dehumidification heater for main paper feed tray [A] and tighten it.

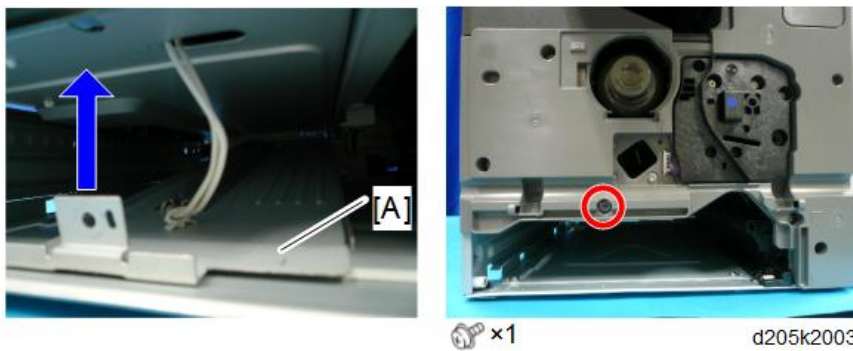

12. Connect the connector [A] of the dehumidification heater for main paper feed tray and the harness [B] (No.7 in the accessory list).

## Dehumidification Heaters

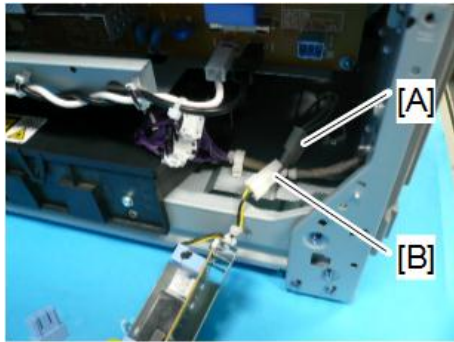

d205k2004

13. Install the DHB assembly [A].

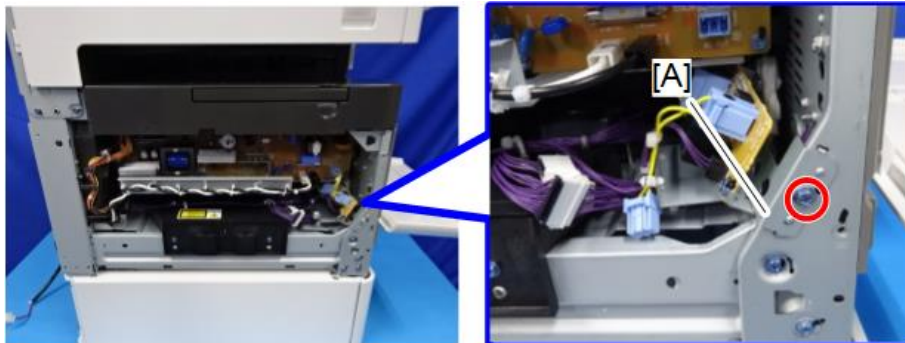

 x1

d205z2116



14. Connect the connector [A] of the harness (short) to the PSU [B].

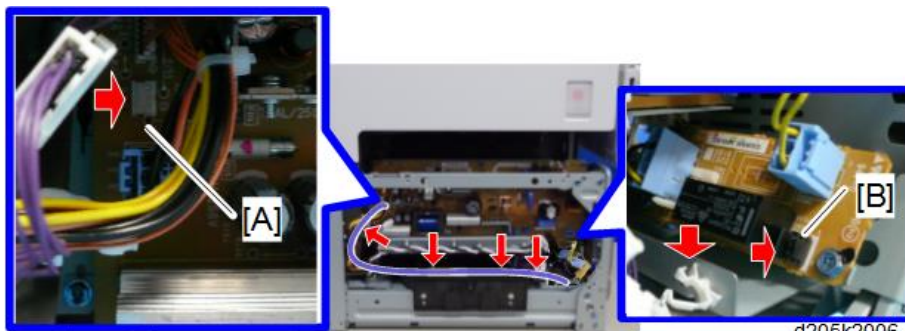

d205k2005

15. Connect the connector of the harness (long) to the connector [A] on the PSU and the connector [B] on the DHB.



 x2  x5

d205k2006

16. Reassemble the machine.
17. To activate the dehumidification heater, set the value of SP5-805-001 to "1".

## 1.6.2 DEHUMIDIFICATION HEATER FOR OPTIONAL PAPER FEED TRAY

### Accessory Check

No.	Description	Q'ty	Note
1	Tapping screw	6	
2	Clamp	11	
3	Edge saddle	2	Not used
4	Heater	1	
5	Bracket for heater	1	
6	Bracket for DHB	1	
7	DHB	1	
8	Harness (short)	1	DHB/PSU
9	Bank harness	1	
10	Relay harness	1	
11	Harness (long)	1	DHB/PSU
-	Decal	1	

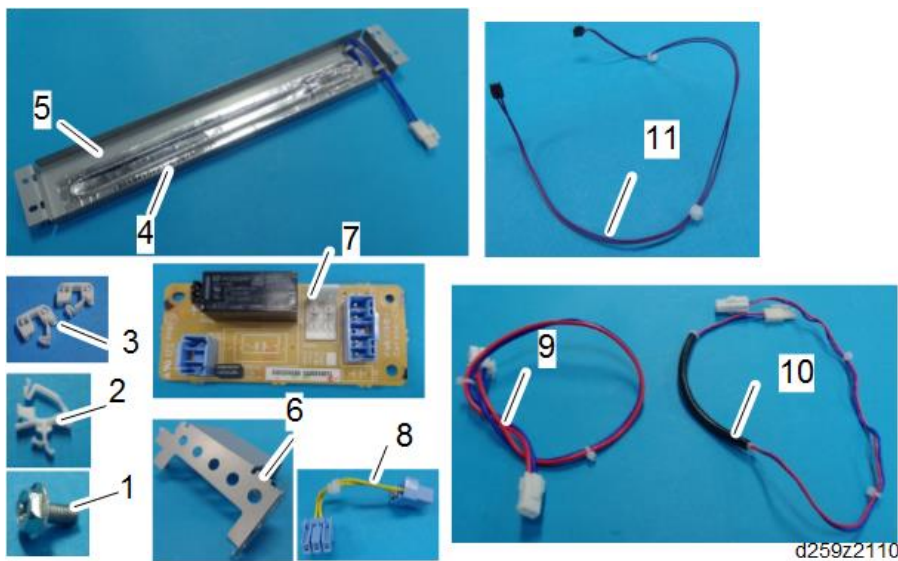

## Installation Procedure

### ⚠ CAUTION

- You need two or more persons to lift the main machine. The main machine is highly unstable when it is lifted by one person, and may cause injury or property damage.
- Be sure to hold the specified positions when lifting the machine.

#### 1. Assemble the DHB, bracket, and connectors as shown below.

The numbers in the following picture represents the number in the accessory list.

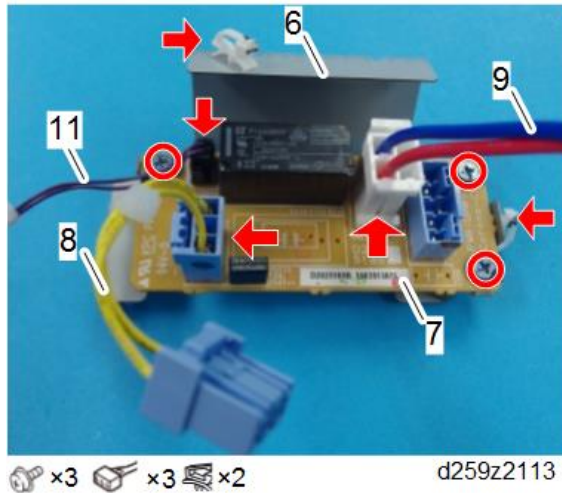

2. Remove the optional paper feed tray from the main machine (if it is installed).
3. Remove the screw covers [A], and then remove the rear cover [B].

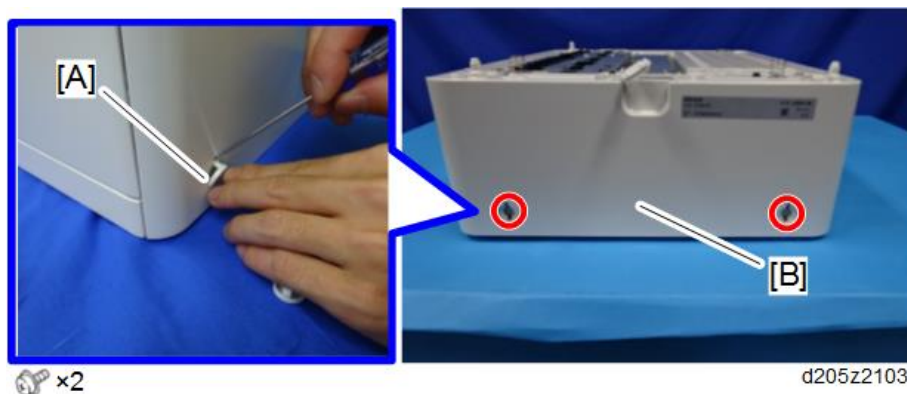

#### 4. Assemble the heater and bracket.





 x2 d259z2114

5. Install the heater assembly.

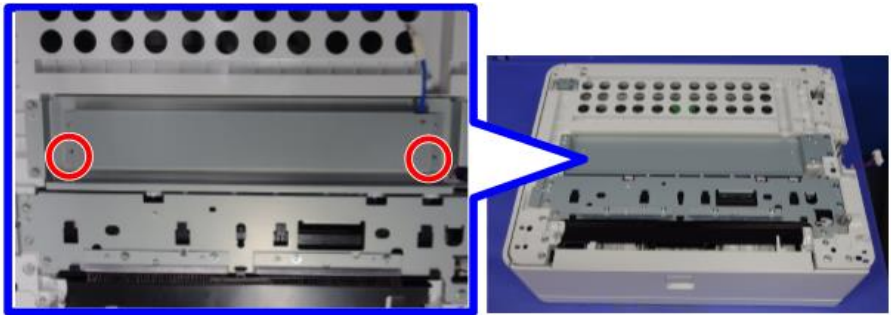

 x2 d259z2115

6. Route the relay harness [A].

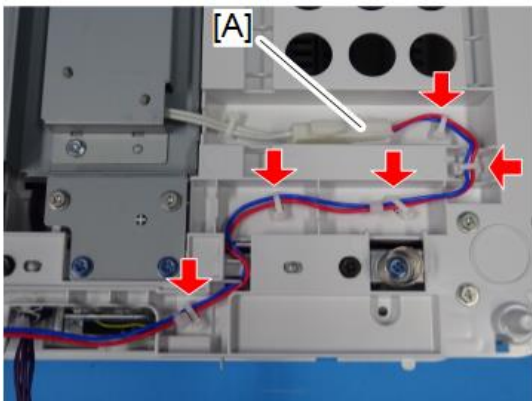

 x5 d205z2105

7. Remove the T-shaped cover [A].



d205m4002

8. Remove the screws from the rear cover [A].

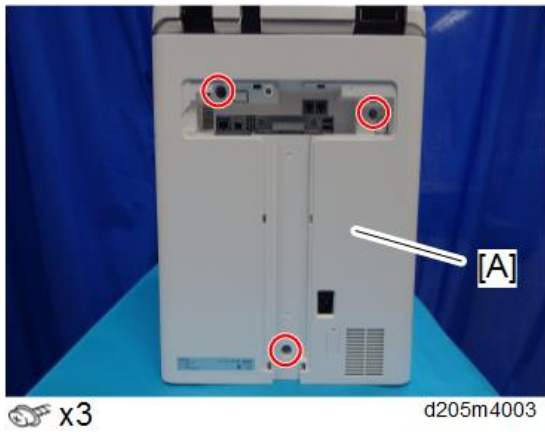

9. Open the right cover.

10. Remove the rear cover [A].



**Note**

- Be careful not to damage the tabs at the rear of the left cover when removing or installing the rear cover.

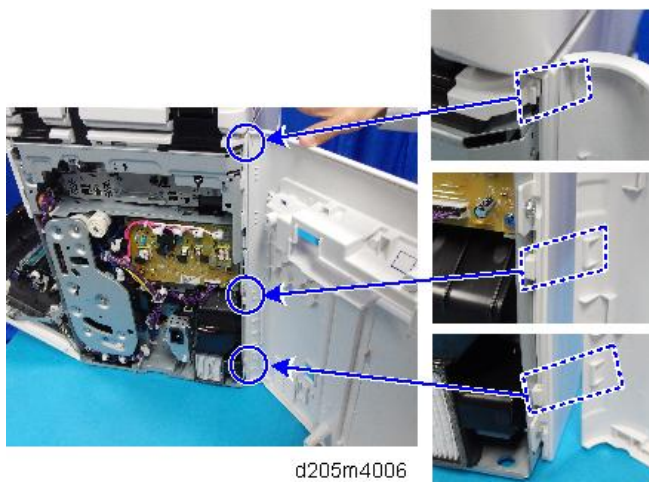

11. Open the front cover and pull the main paper feed tray.

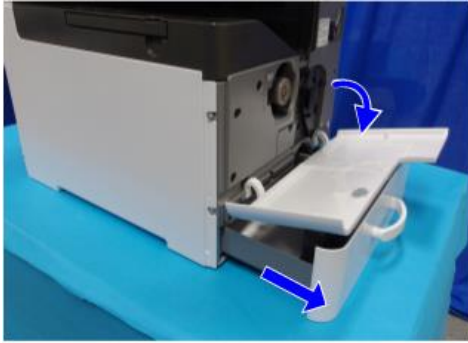

d205z4014

**12. Remove the left lower cover [A].**

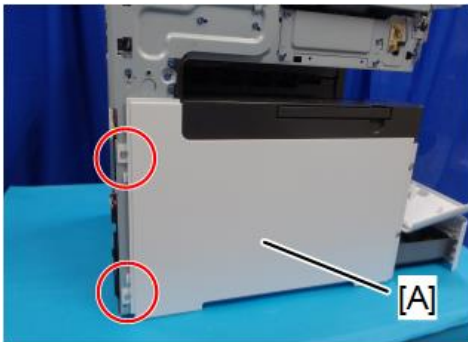

🔑 x2

d205m4014

**Note**

- To remove the left lower cover [A], slide it to the rear.

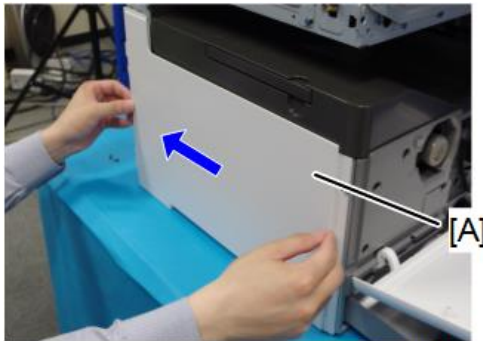

d205m4015

- Be careful not to damage the positioning boss [B] and tabs.

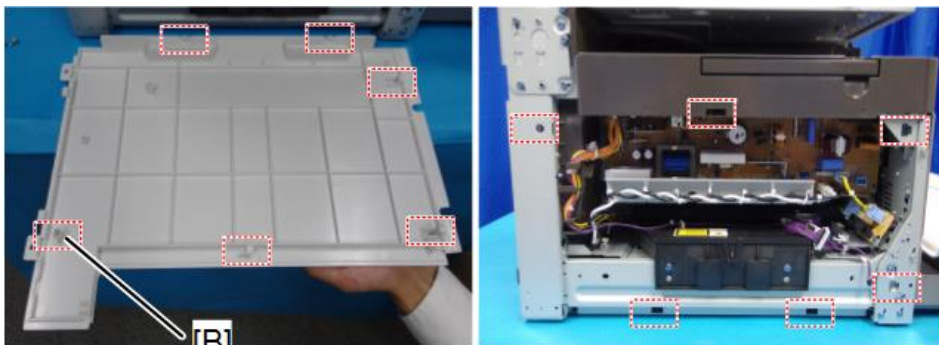

d205m4016

**13. Set the main machine on the optional paper feed tray.**

**14. Do the following:**



## Dehumidification Heaters

1. Attach the joint bracket [A].
2. Clamp the harness [B] and relay harness [C].

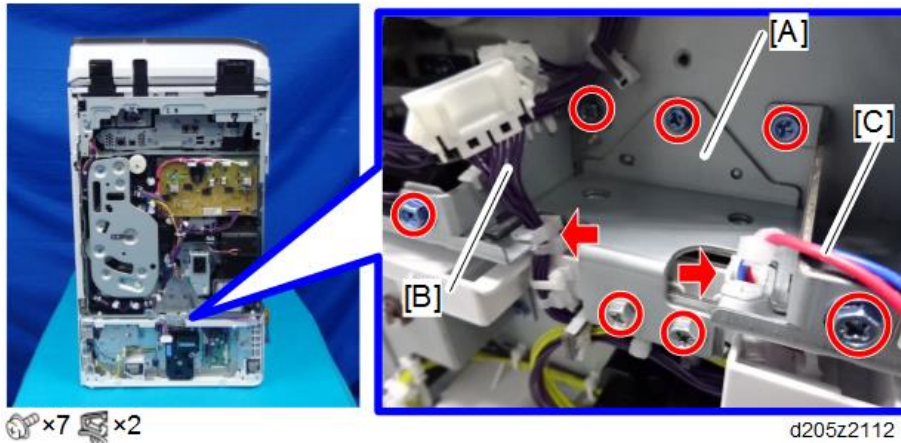

15. Connect the harness coming from the main machine [A] with the harness [B] clamped in step 14.

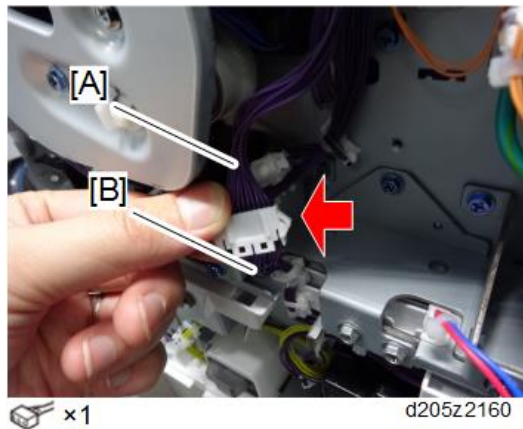

16. Install the DHB assembly [A].

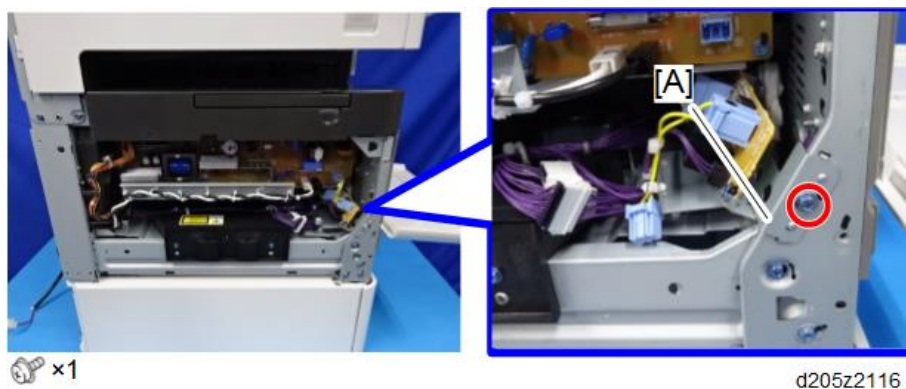

17. Connect the connector [A] of the harness (short) to the PSU [B].



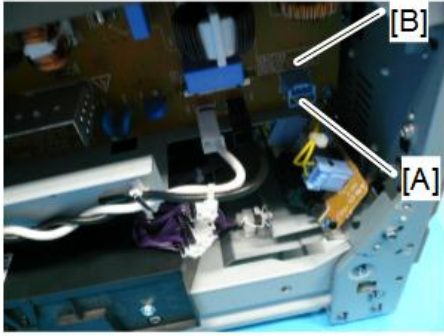

d205k2005

18. Connect the connector of the harness (long) to the connector [A] on the PSU and the connector [B] on the DHB.

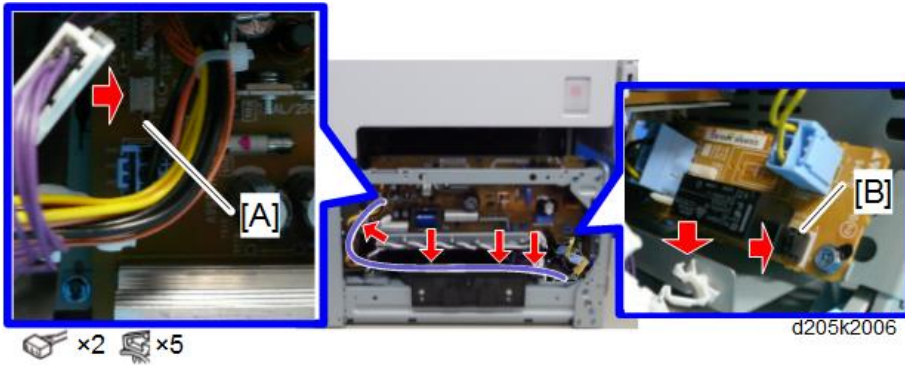

19. Route the bank harness to the rear of the machine.

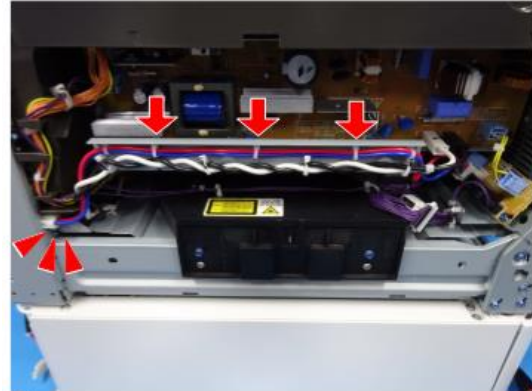

× 3

d205z2118

20. Remove the dust filter [A] and route the relay harness to join the bank harness at the rear of the machine.

Attach the filter again after you finished routing.

## Dehumidification Heaters

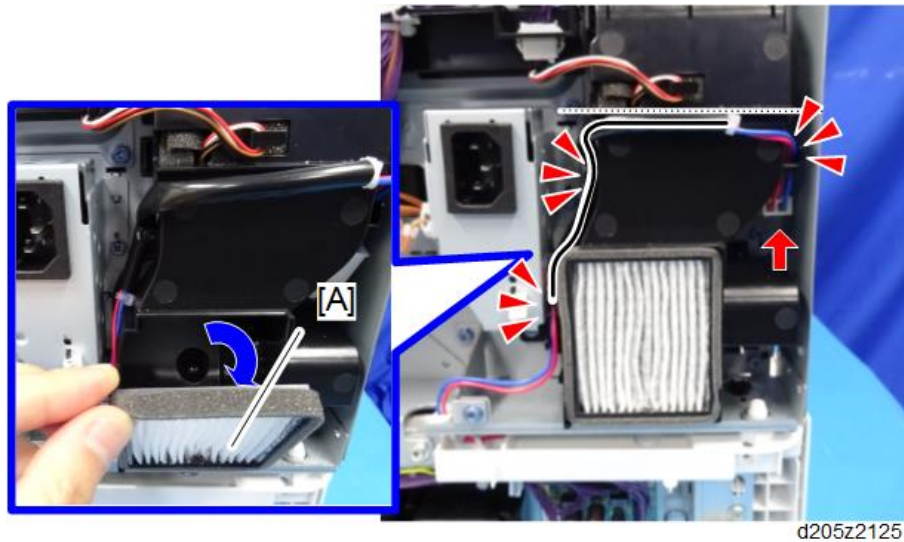

21. Remove the special tool [A].

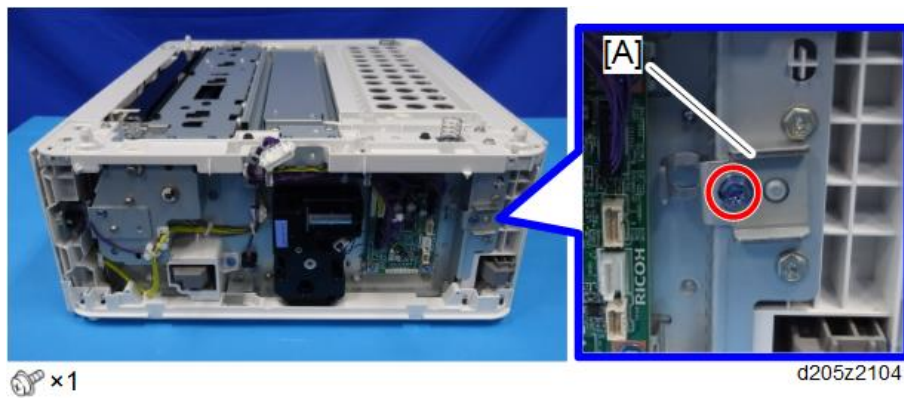

22. Remove the main paper feed tray.

23. Tighten the optional paper feed tray to the main machine using the special tool (removed in step 21).



24. Reattach the special tool at the storage position.

25. Reassemble the machine.

## 1.7 COPY DATA SECURITY UNIT TYPE G

### 1.7.1 ACCESSORY CHECK

No.	Description	Q'ty	For this model
1	ICIB-3	1	Yes
2	Bracket	1	Yes
3	Screws: M3x6	4	Yes* *Uses only two screws for this model
4	Small bracket	1	Not used
5	Screws: M3x4	2	Not used
6	Spacer:SQ-7	1	Not used
7	Screws: M3x8	2	Not used

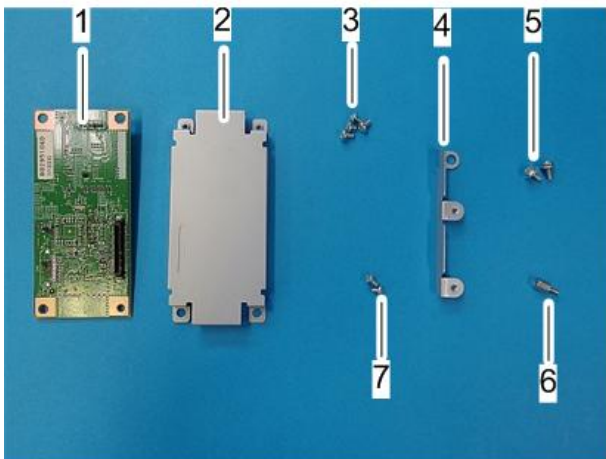

d197f0132

## 1.7.2 INSTALLATION PROCEDURE

### ⚠ CAUTION

- Turn OFF the main power and disconnect the power supply cord.

#### 1. Open the front cover and remove the cover [A].

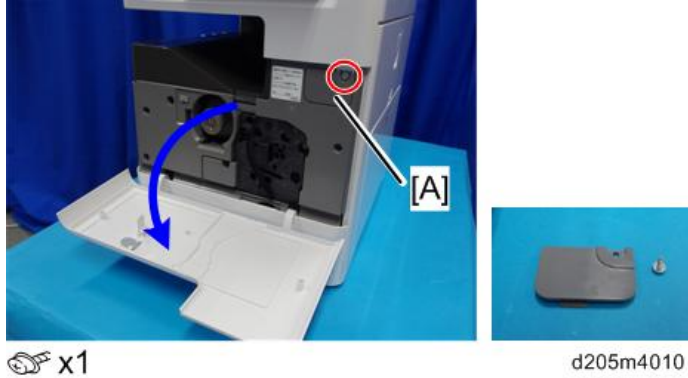

#### 2. Remove the front upper cover [A].

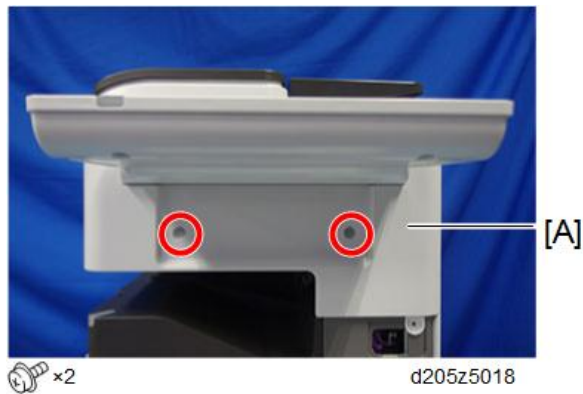

#### 3. Slide and remove the left upper cover [A]. (Positioning boss [B])

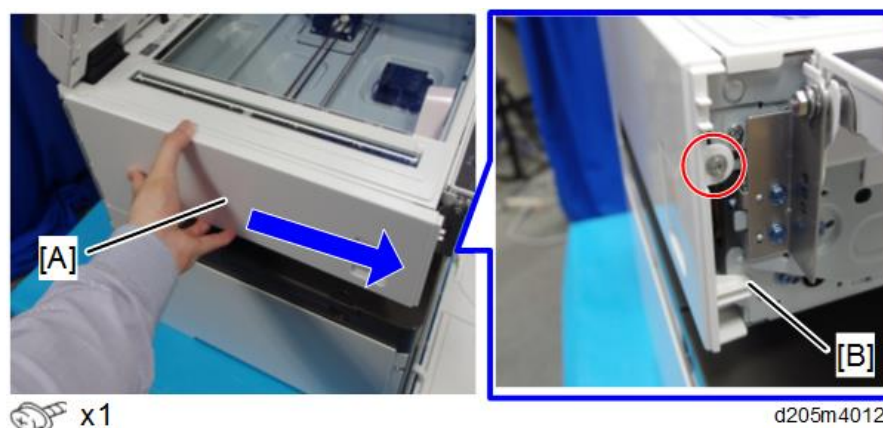

#### ⓘ Note

- Be careful not to damage the two tabs at the rear when removing or installing.

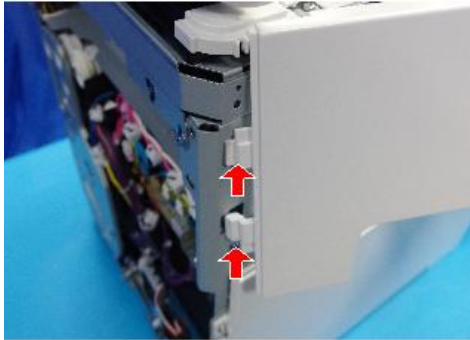

d205m4013

4. Remove the T-shaped cover [A].



d205m4002

5. Remove the screws [A].

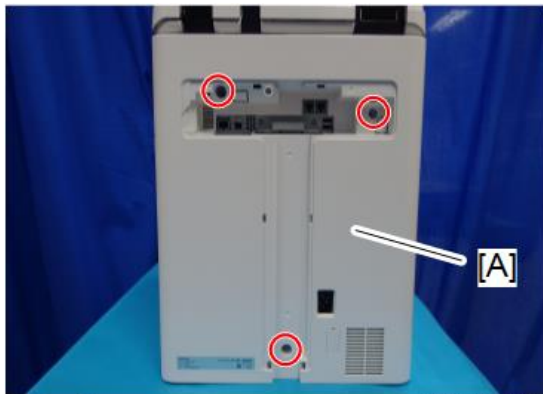

 x3

d205m4003



6. Open the right cover.

7. Remove the rear cover [A]. (tab x2)

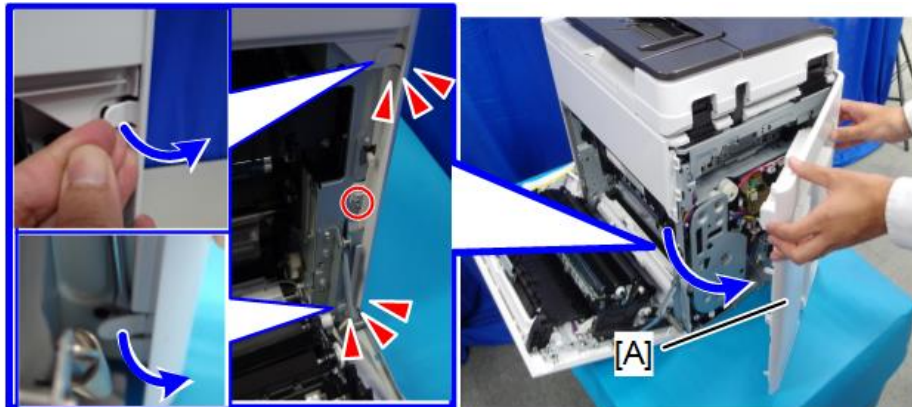

🔑 x1

d205m4005

⬇️ **Note**

- Be careful not to damage the tabs at the rear of the left cover when removing or installing the rear cover.

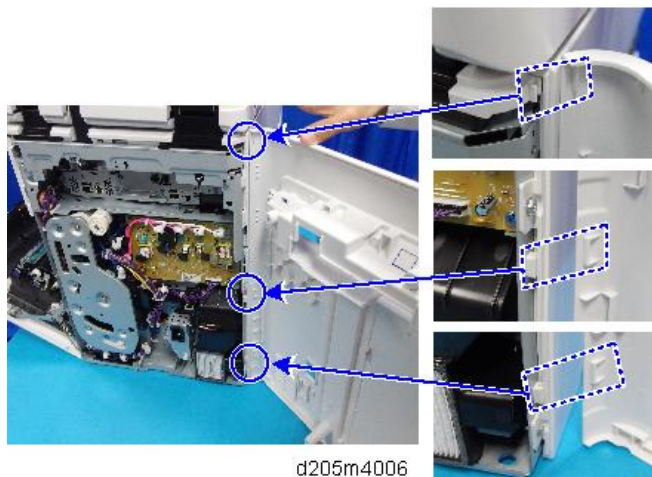

d205m4006

8. Slide and remove the right upper cover [A].



🔑 x2

d205m4007

⬇️ **Note**

- Be careful not to damage the positioning boss and the tabs on the cover when you remove or install.

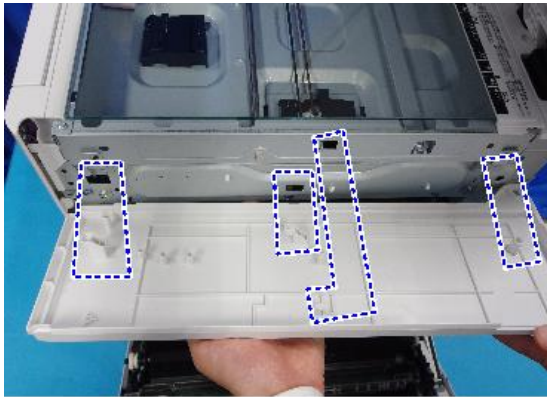

d205m4008

9. Slide the scanner unit about 10 cm to the right.

10. Release the FFC on the BiCU.

Unlock the connector and release it.

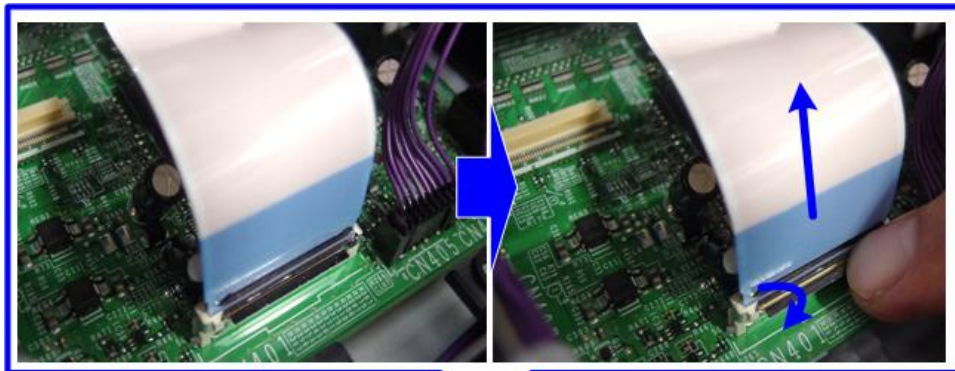

x1

d205m4031

11. Release all the other harnesses and remove the scanner unit [A].

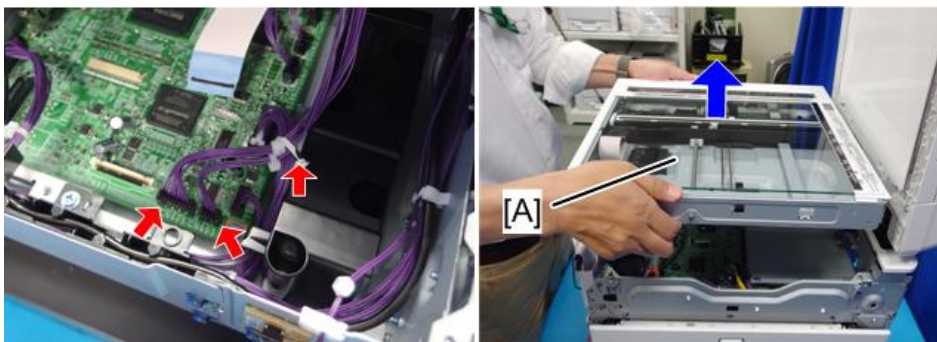

x1, x2

d205m4032

12. Connect the connector [A] on the ICIB-3 and the connector (CN204) [B] on the BiCU.

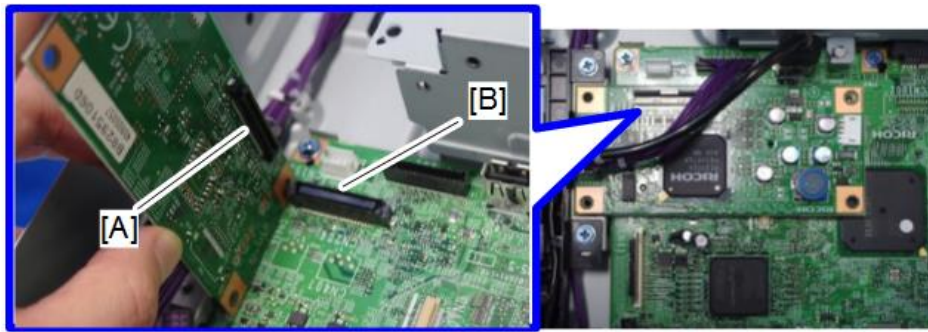

d205z2133

13. Attach the bracket to the ICIB-3.

Make sure that the connector and the dent enclosed in the red-dotted line below fits correctly.

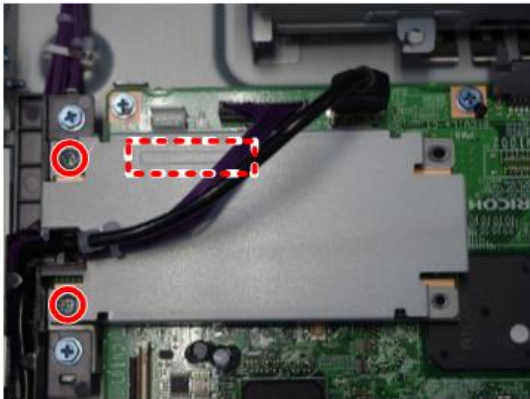

🔑 ×2

d205z2132

14. Plug in the machine and turn ON the main power.

⬇️ **Note**

- If this option is installed correctly, the LED on the ICIB-3 blinks.

15. Reassemble the machine.

### ***User Tool Setting***

1. Plug in the machine and turn ON the main power.
2. Go into the User Tools mode, and select System Settings > Administrator Tools > Copy Data Security Option > “On”.
3. Exit User Tools.



**4. Check the operation.****Note**

- The machine will issue an SC165 error if the machine is turned ON with the ICIB-3 removed and the “Data Security for Copying” feature set to “ON”.
- The machine will issue an uncertain SC165 error if ICIB-3 is defective when the machine is turned ON and the “Data Security for Copying” feature is set to “OFF”.
- When you remove this option from the machine, first set this feature to “OFF” with the user tool before removing this board. If you forget to do this, “Data Security for Copying” feature cannot appear in the user tool setting. Also, SC165 will appear every time the machine is turned ON, and the machine cannot be used.

**5. Make sure that the machine can recognize the option.**

## 1.8 ENHANCED SECURITY HDD OPTION TYPE M10 (D792-09)

### 1.8.1 ACCESSORY CHECK

No.	Description	Q'ty
1	Enhanced Security HDD	1
-	EMC Address	1



d191b0076

### 1.8.2 INSTALLATION PROCEDURE

1. Remove the T-shaped cover [A].



d205m4002

2. Remove the screws from the rear cover [A].

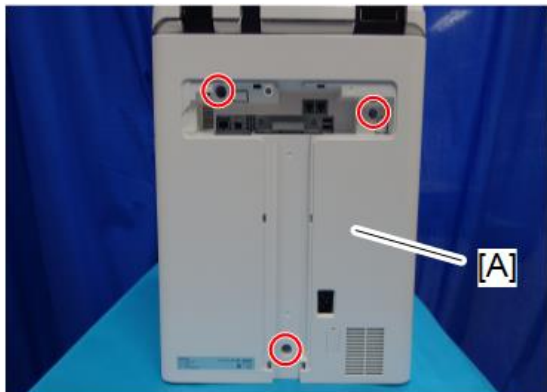

🔑 x3

d205m4003

3. Open the right cover.

4. Remove the rear cover [A]. (tab x 2)

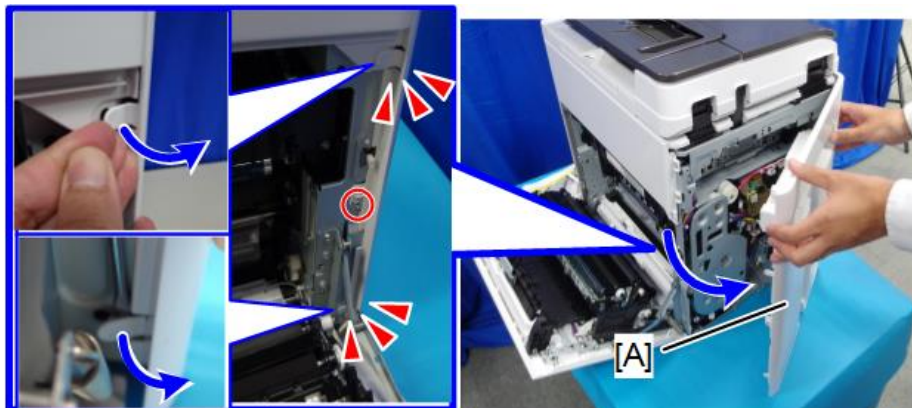

🔑 x1

d205m4005

⬇️ Note

- Be careful not to damage the tabs at the rear of the left cover when removing or installing the rear cover.

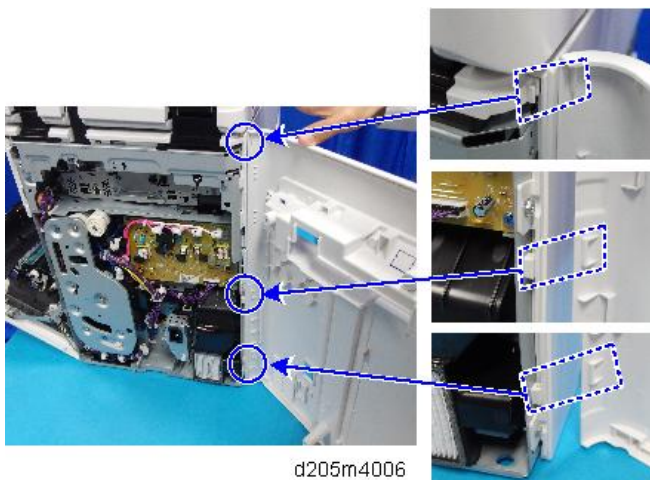

d205m4006

5. Remove the controller box [A].

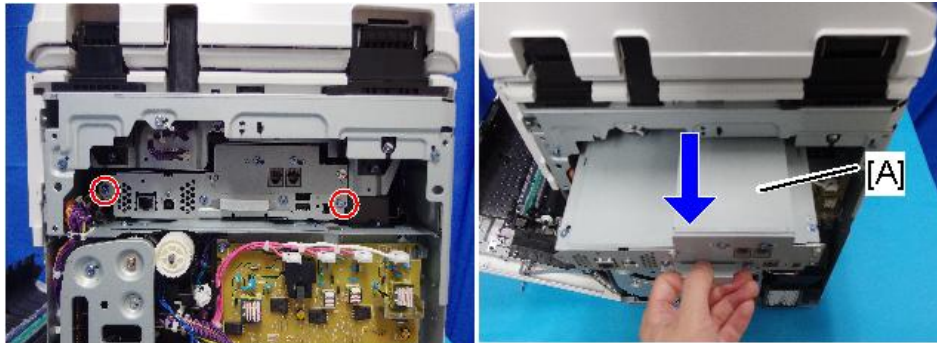

 x2

d205m4107

6. Remove the controller box's upper cover [A].

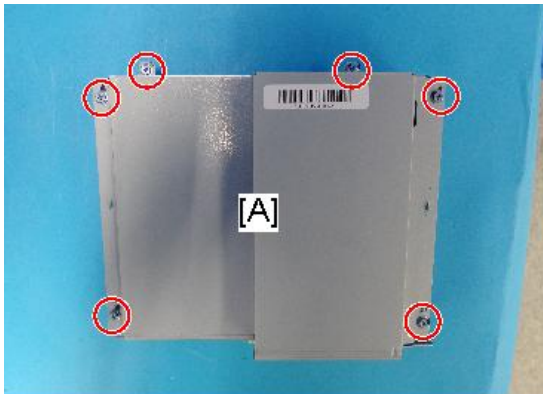

 x6

d205m4109

7. Remove the standard HDD installed.

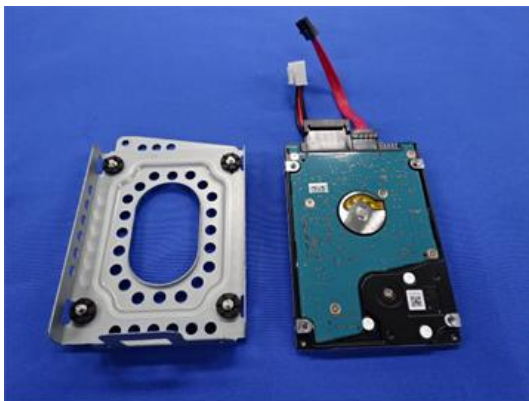

d196z2120

8. Disconnect the cables from the standard HDD. ( x 2)





d191b0077

9. Unpack the enhanced security HDD.



d191b0078

10. Connect the two cables to the enhanced security HDD. (🔌 x 2)



d191b0079

11. Fasten the HDD to the bracket. (🔩 × 4)

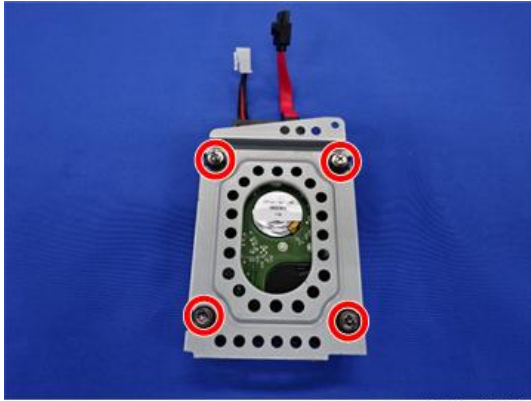

d196z2121

12. Install the HDD bracket in the controller box.

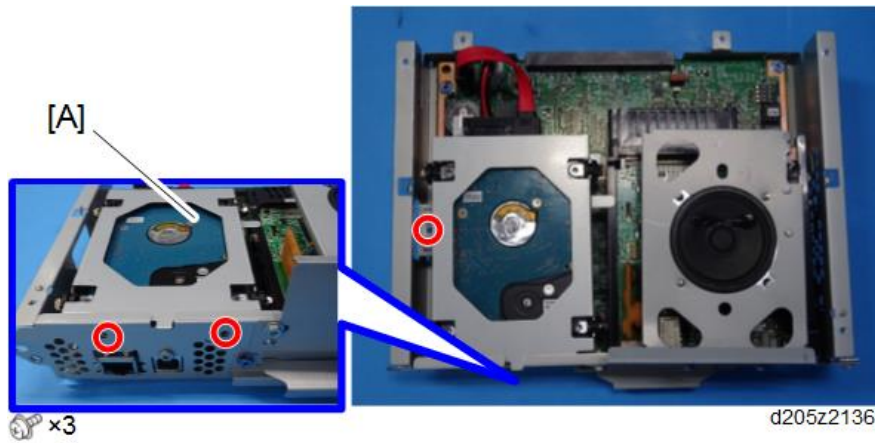

🔩 ×3

d205z2136

13. Reassemble the machine.

**After Installing the HDD**

1. Connect the power cord and turn ON the main power. A message prompts you to format the hard disk.

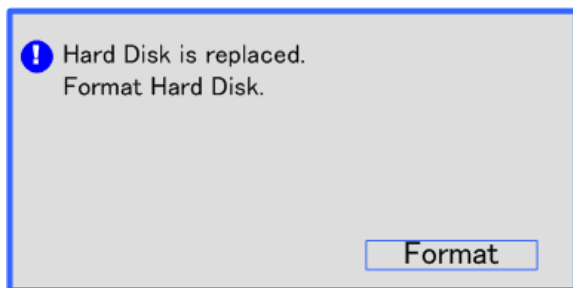

d191b0081

2. Touch [Format].

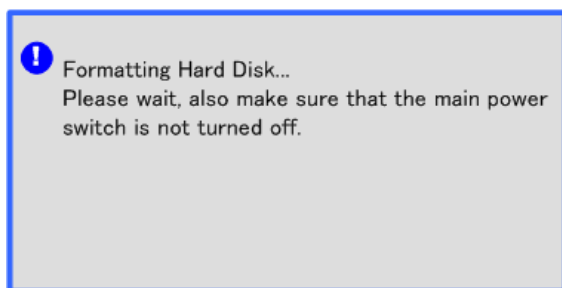

d191b0082

3. Wait for the machine to finish formatting the hard disk.

**★ Important**

- Do not touch the power switch while the hard disk format is in progress. Wait for the machine to tell you that the formatting is finished.

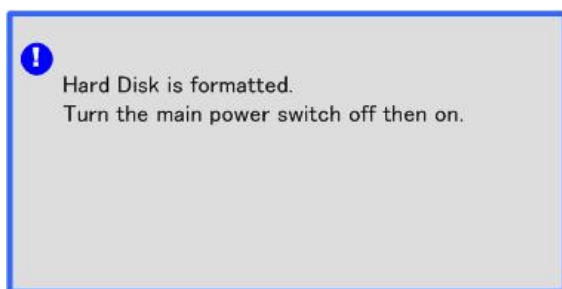

d191b0083

4. Turn OFF then ON the main power after the message tells you formatting is finished.
5. Enter the SP mode.
6. Do SP5-846-040 to copy the address book to the hard disk from the controller board.
7. Do SP5-846-041 to let the user get access to the address book.
8. Turn OFF then ON the main power.
9. Ask an administrator to register an HDD authentication code in the machine.

**★ Important**

- If the HDD Authentication Code is not registered, the function of the enhanced security HDD is not activated.

## 1.9 NFC CARD READER TYPE M15 (D3B4)

### 1.9.1 ACCESSORY CHECK

No.	Item	Q'ty
1	NFC Card Reader	1
2	USB cable	1
3	Cushion	1
4	Decal	1
-	EMC Address	1
-	Caution chart	1

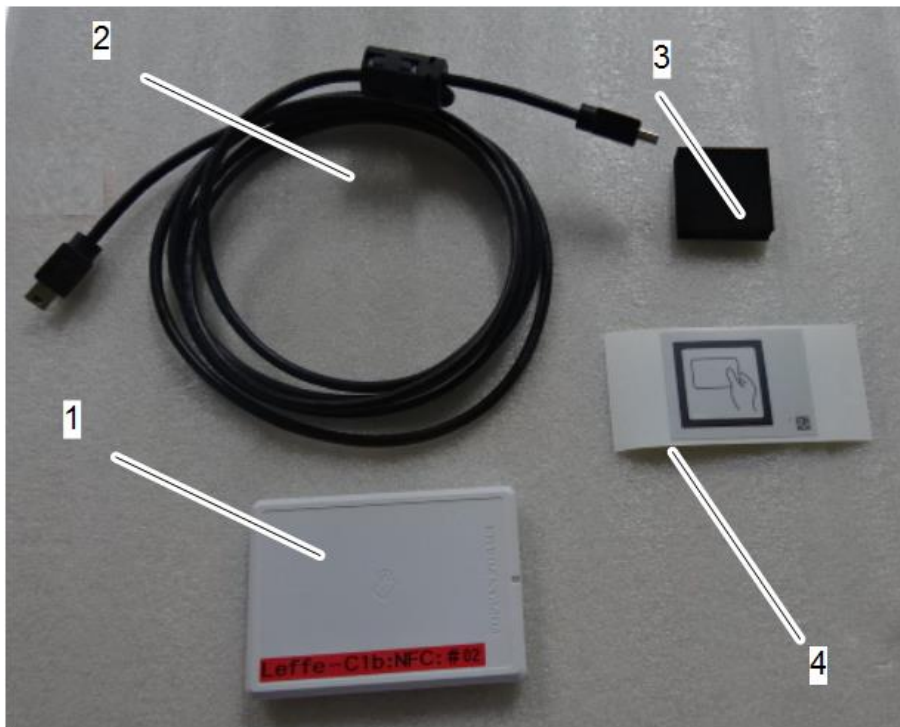

d205z2220



## 1.9.2 INSTALLATION PROCEDURE

1. Remove the T-shaped cover [A].



2. Remove the screws from the rear cover [A].

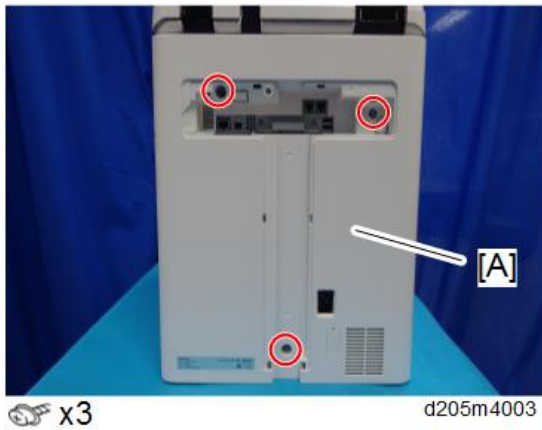

3. Open the right cover.
4. Remove the rear cover [A]. (tab x 2)



**Note**

- Be careful not to damage the tabs at the rear of the left cover when removing or installing the rear cover.

# NFC Card Reader Type M15 (D3B4)

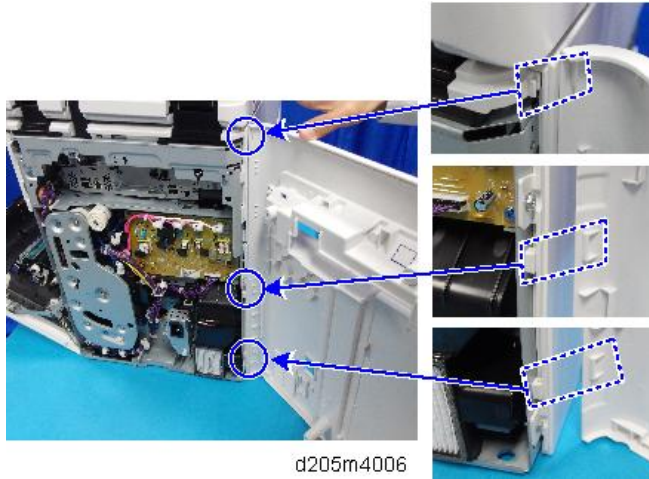

- 5. Open the ARDF feed cover [A].



- 6. Remove the screw from the ARDF front cover [A].

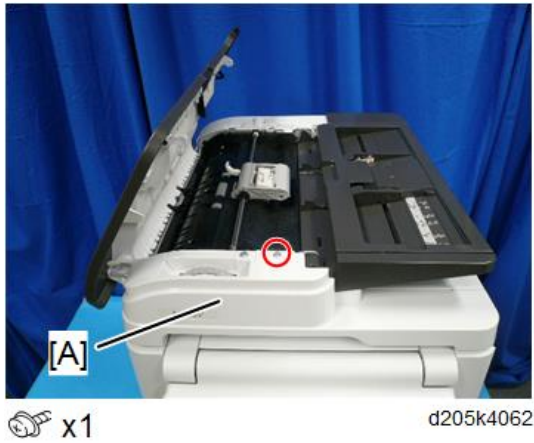

- 7. Open the copy holder [A] and then release the lock.

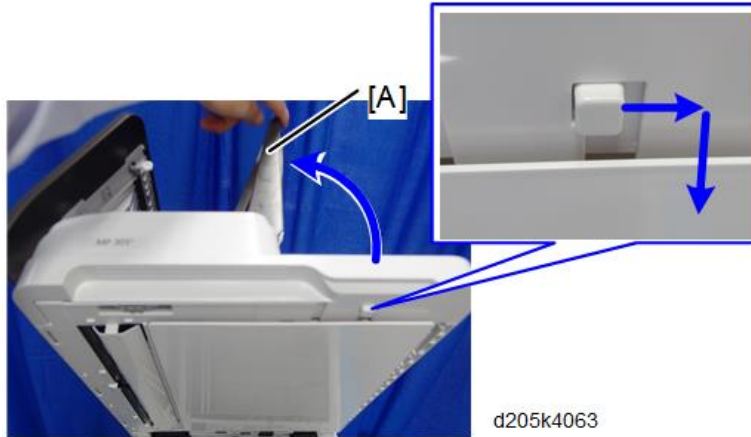

8. Remove the ARDF front cover [A].

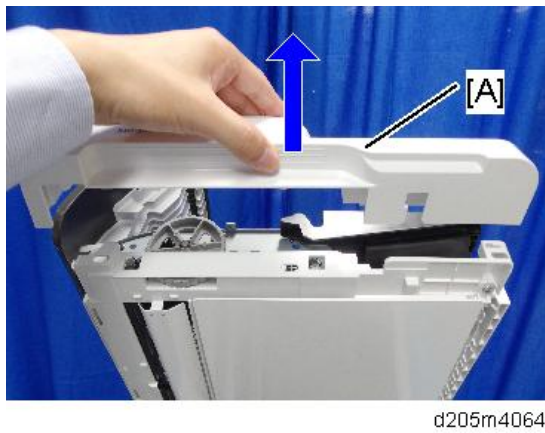

9. Remove the screw from the ARDF rear cover [A].

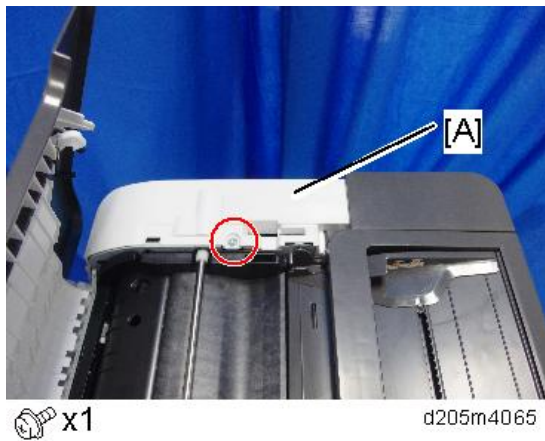

10. Release the tabs (3 points).

## NFC Card Reader Type M15 (D3B4)

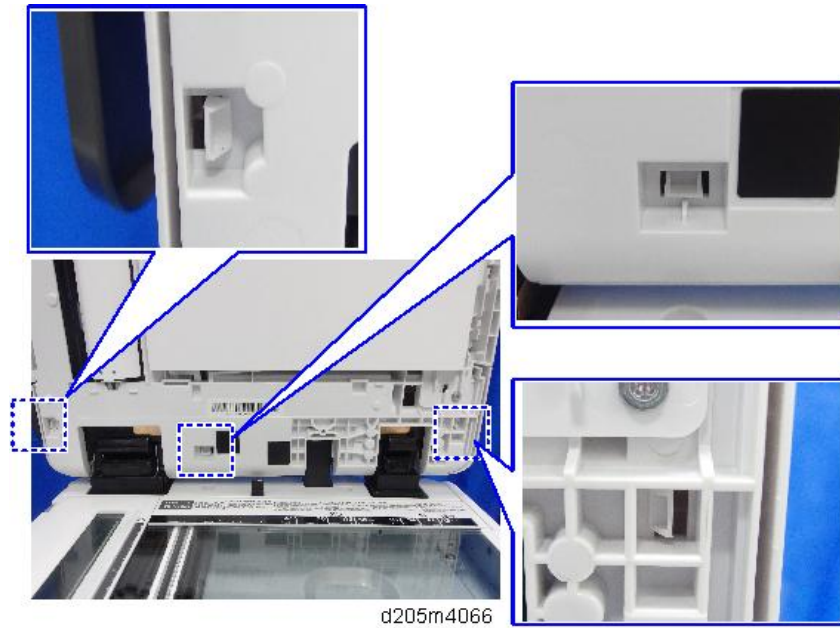

11. Open the copy holder [B] and the ARDF feed cover [C]. And then remove the ARDF rear cover [A].

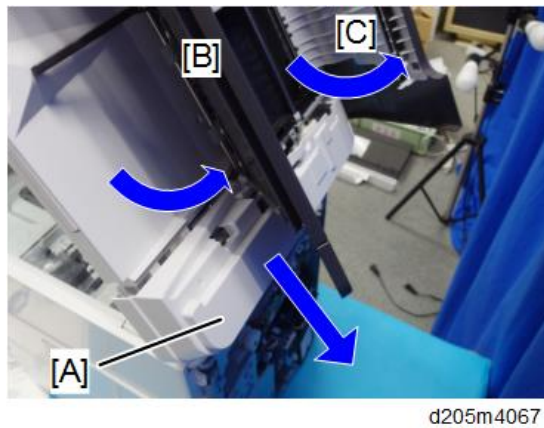

12. Attach the cushion [A] included in the accessories to the back of the NFC card reader.



13. Connect the USB cable to the NFC card reader.

### Note

- Connect the card reader to the ferrite core side.





d205z2222

14. Open the ARDF and pass the USB cable [A] through the hole [B] in the front of the ARDF.

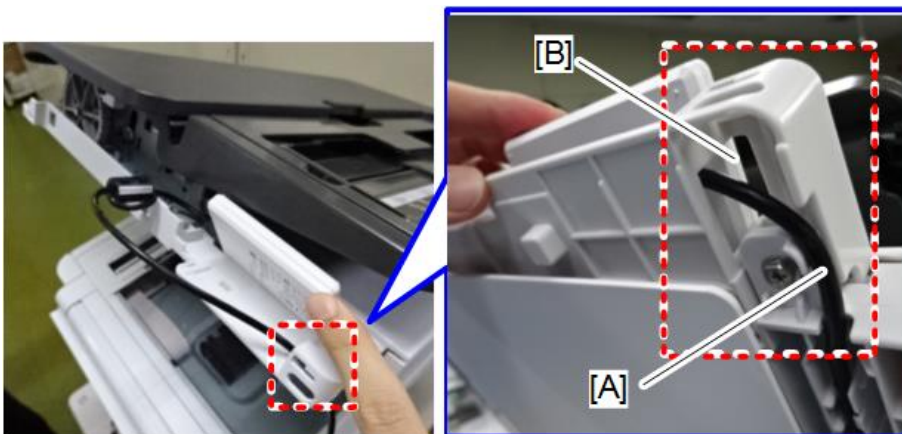

d205z2300

15. Place the NFC card reader.

Make sure that the NFC card reader [B] fits inside the ARDF frame.  
Also make sure that the ferrite core [A] fits inside the ARDF frame.

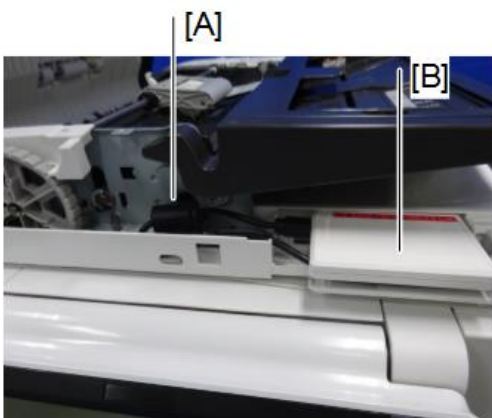

d205z2224

16. Attach the ARDF front cover.

17. Route the USB cable along the cable guide ([A] or [B]) and pass it through the hole [C].  
[D] shows the hole [C] from another angle .

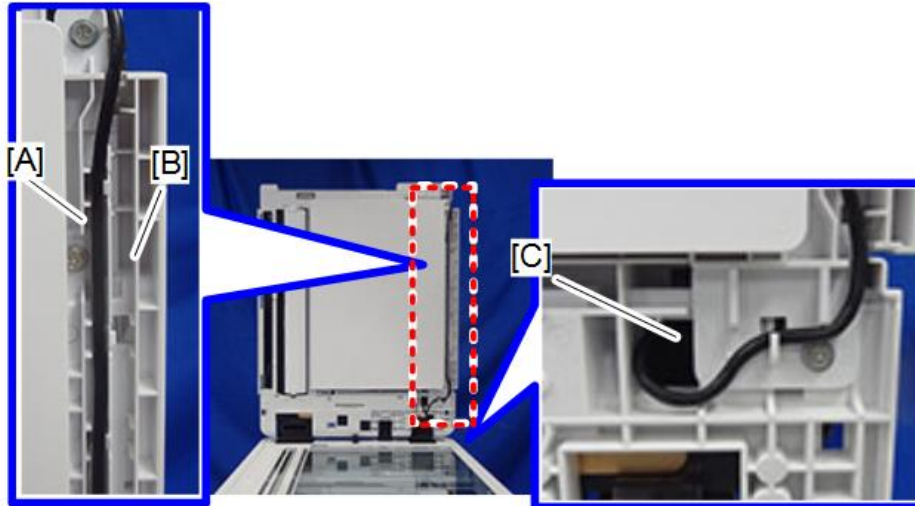

d205z2225

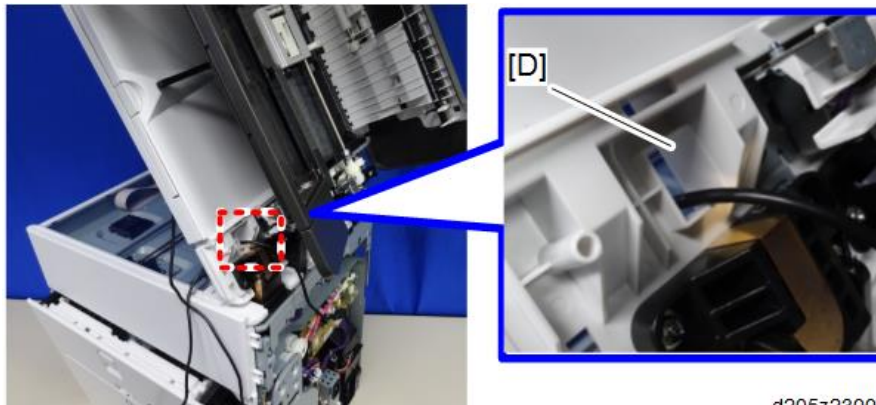

d205z2300

**Note**

- There are two ways for routing USB cable:
- Narrower route [A]: for product provided by RICOH.  
Wider route [B]: for product provided by third-party.

**18. Pass the USB cable through the ARDF hinge [A].**

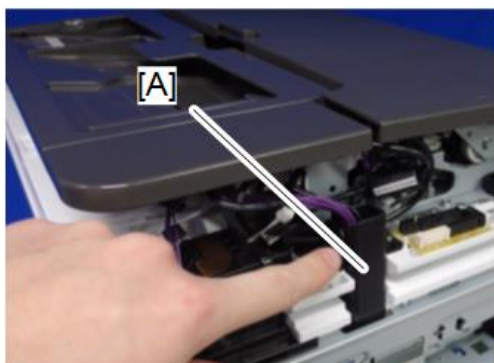

d205z2227

**19. Remove the front upper cover.**

1. Open the front cover and remove the cover [A].

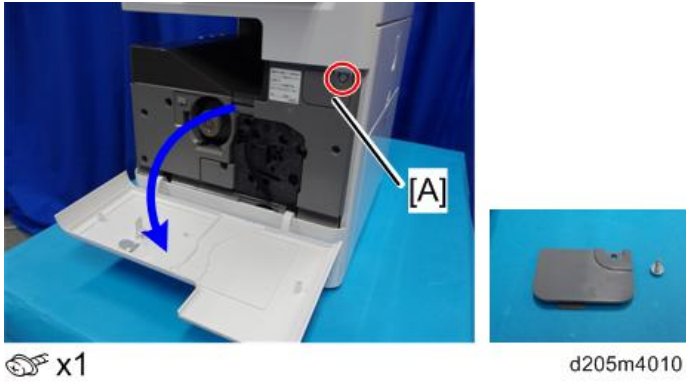

2. Remove the front upper cover [A].



20. Slide and remove the right upper cover [A].



**Note**

- Be careful not to damage the positioning boss and the tabs on the cover when you remove or install.

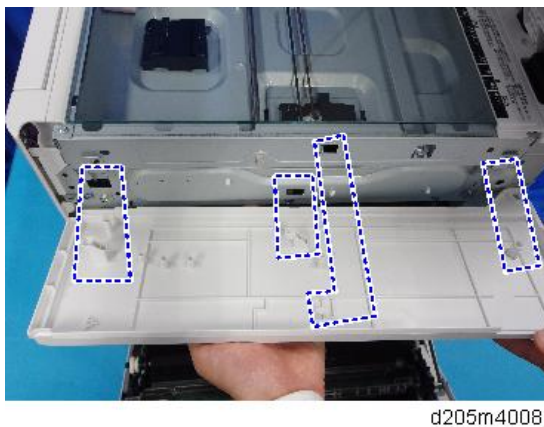

**21. Slide and remove the left upper cover [A]. (Positioning Boss [B])**

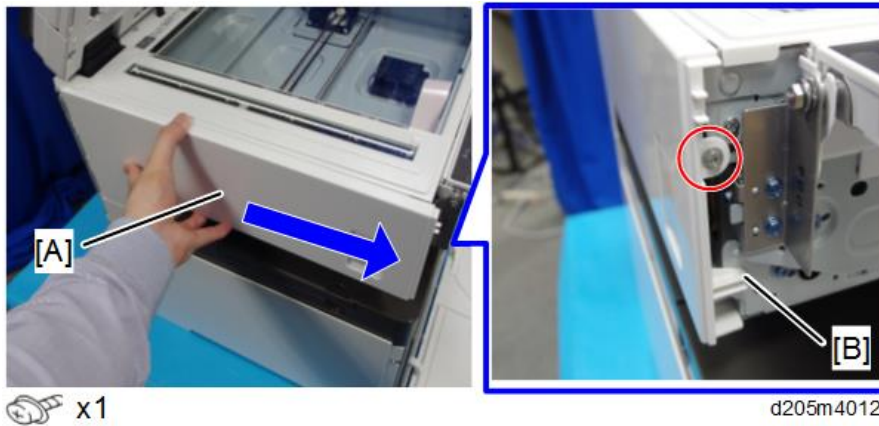

**22. Remove the screws and slide the scanner unit about 10 cm to the left.**



**23. Pass the USB cable [A] to the front side through the gap [B] on the rear.**

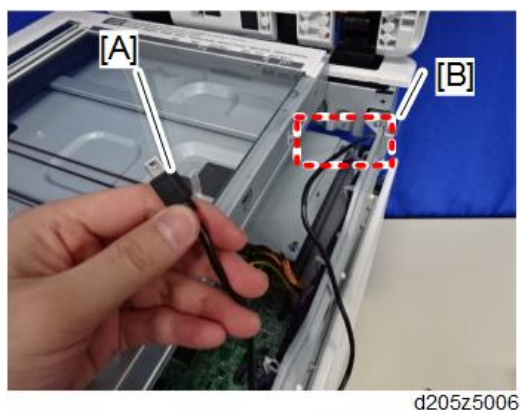

**24. Route the USB cable and pass it through the hole [A] in the front of the machine.**



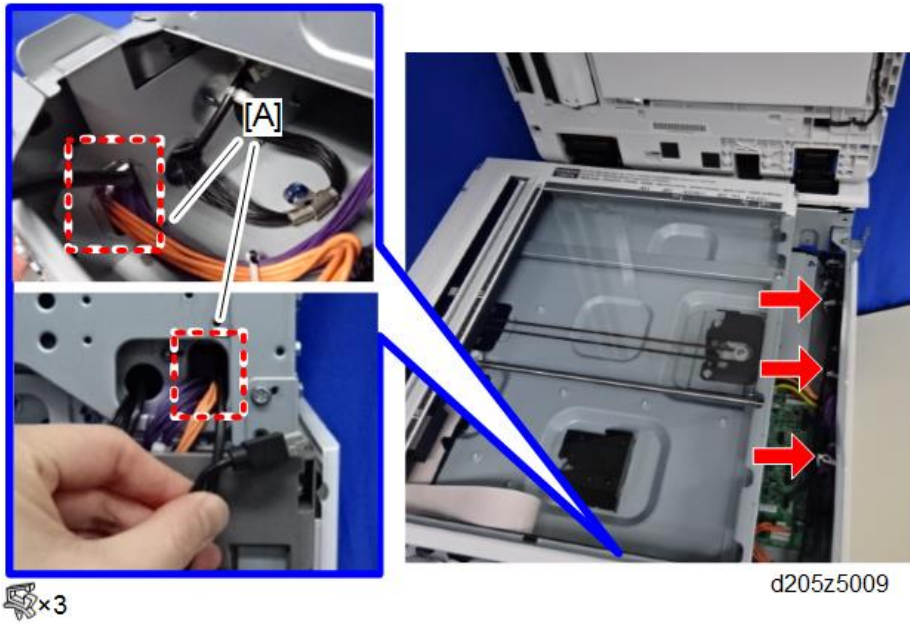

**25. Remove the operation panel.**

1. Place the service mat on top of the ARDF.
2. Remove the brackets [A] of the operation panel unit.

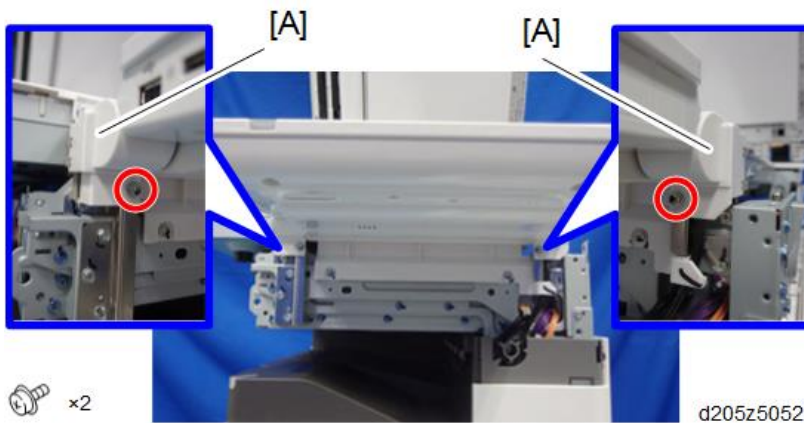

3. Remove the hinges of the operation panel unit.

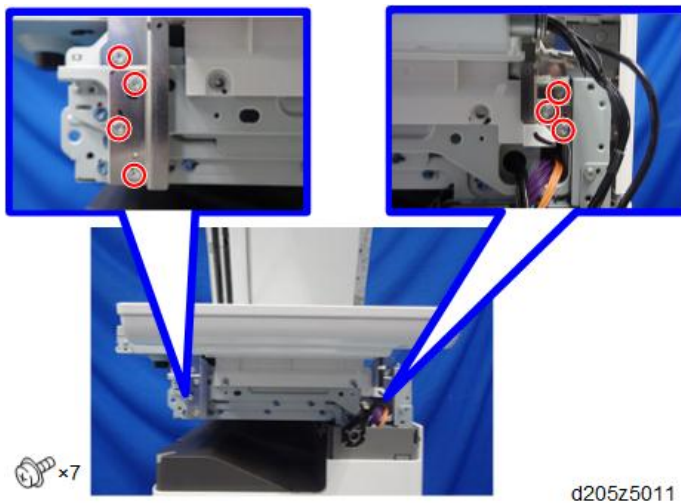

## NFC Card Reader Type M15 (D3B4)

4. Remove the operation panel unit and put it on the service mat.
5. Remove the rear cover [A] of the operation panel unit.

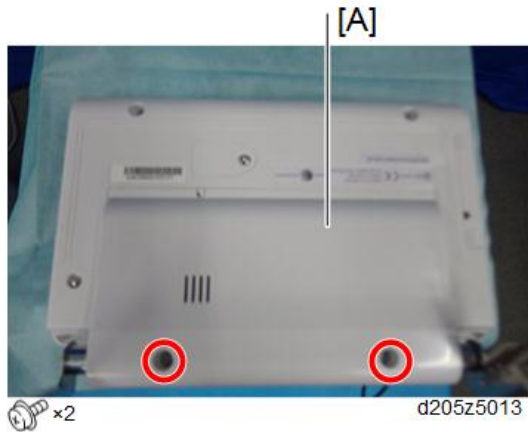

**26. Remove the operation panel's USB cable and connector that were originally connected.**

**27. Do the following:**

1. Remove the operation panel's I/F cover [B].
2. Pass the NFC's USB cable (①), then the connector (②: originally connected), and the USB connector (③: originally connected) through the connector duct [A]. Check the harness number and connecting location in the photo below.
3. Attach the operation panel's I/F cover [B]. Note that the USB cable fits into the slit.

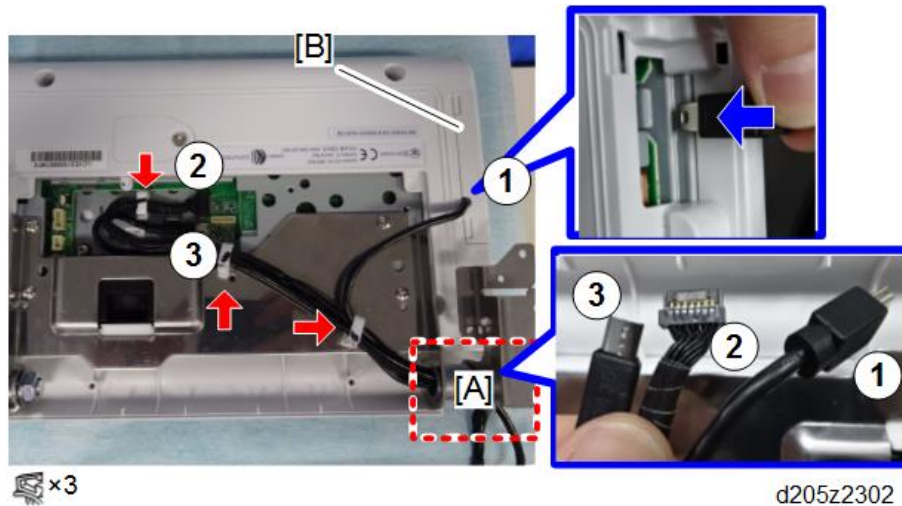

**28. Reassemble the operation panel unit.**

**29. Reinstall the operation panel unit.**

**30. Route the cables as shown below.**

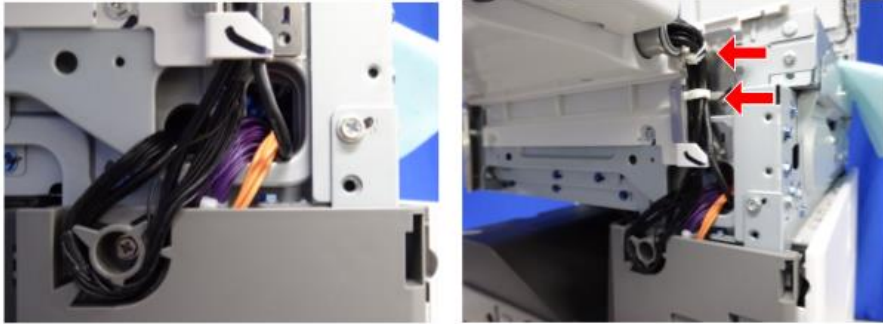

x2

d205z2303

**Note**

- It is not necessary to clamp and hook the cable if you use a third party product that has a thick cable.
- However, wherever possible, arrange the cables to avoid touching the components inside the machine.

**31. Reattach the covers, and reassemble the machine.**

**32. Attach the decal on the area [A] as shown below.**



d205z4022

**33. Turn ON the main power and check the NFC card reader operation.**

## 1.10 OPTIONAL COUNTER INTERFACE UNIT TYPE M12

### 1.10.1 ACCESSORY CHECK

No.	Description	Q'ty
1	MKB Board	1
2	EMC Address Decal	1
3	Tapping Screw: M3x6	4
4	Harness Clamp: LWS-0711	1
5	Stud	4
6	Harness Band	1
7	Harness	1

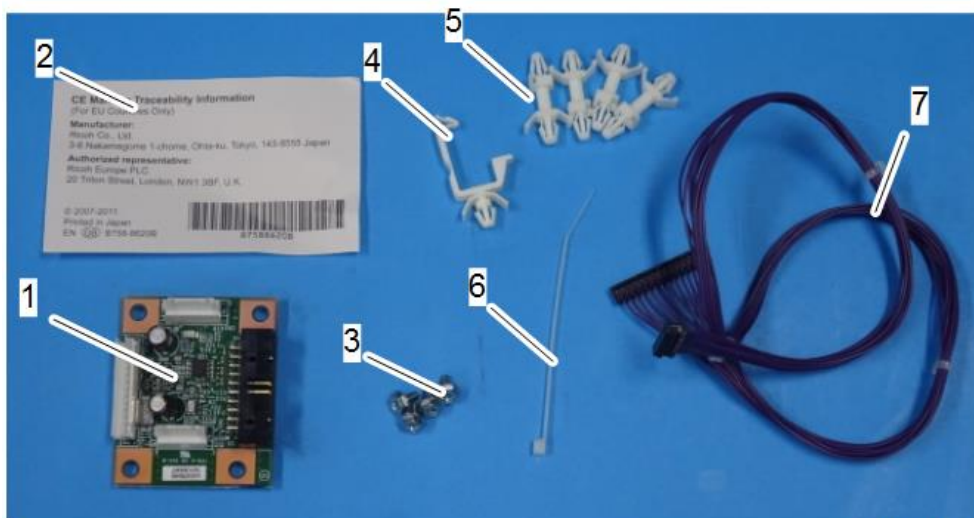

d205z2163

## 1.10.2 INSTALLATION PROCEDURE

1. Open the front cover and remove the cover [A].

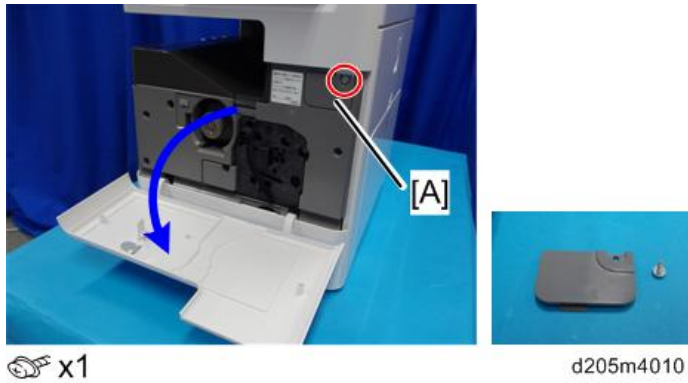

2. Remove the front upper cover [A].



3. Slide and remove the left upper cover [A]. (Positioning Boss [B])

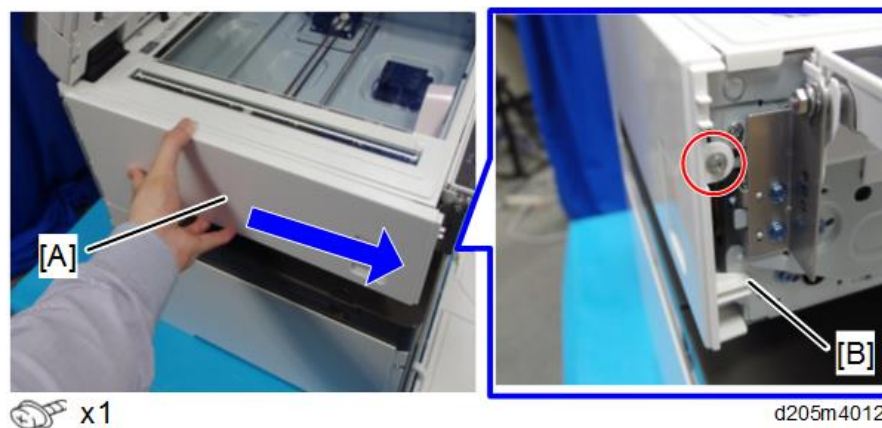

**Note**

- Be careful not to damage the two tabs at the rear when removing or installing.



## Optional Counter Interface Unit Type M12

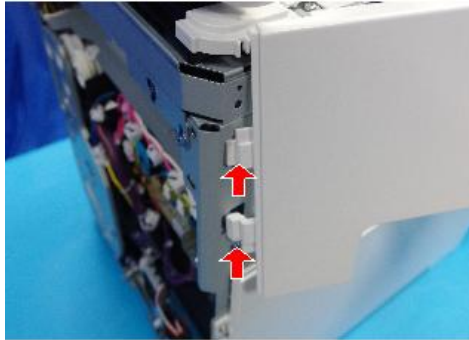

d205m4013

4. Remove the T-shaped cover [A].



d205m4002

5. Remove the screws from the rear cover [A].

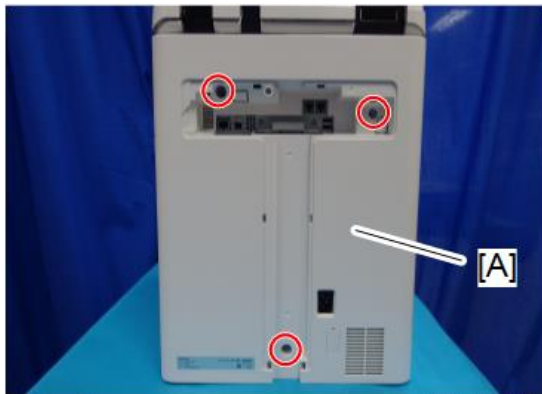

 x3

d205m4003

6. Open the right cover.
7. Remove the rear cover [A]. (tab x2)



 x1

**Note**

- Be careful not to damage the tabs at the rear of the left cover when removing or installing the rear cover.

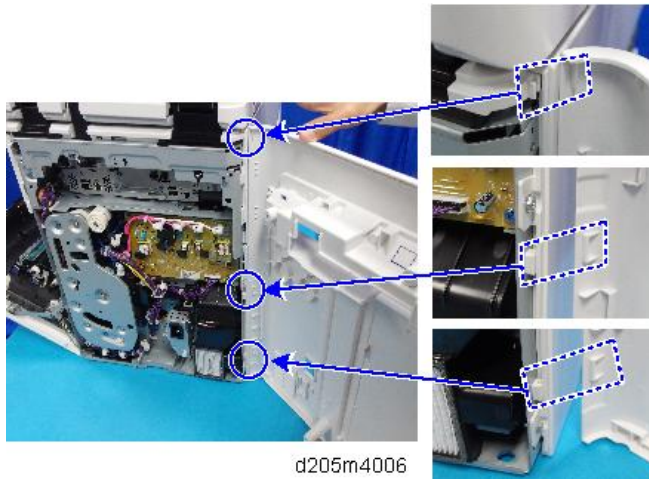

**8. Slide and remove the right upper cover [A].**



 x2

**Note**

- Be careful not to damage the positioning boss and the tabs on the cover when you remove or install.

## Optional Counter Interface Unit Type M12

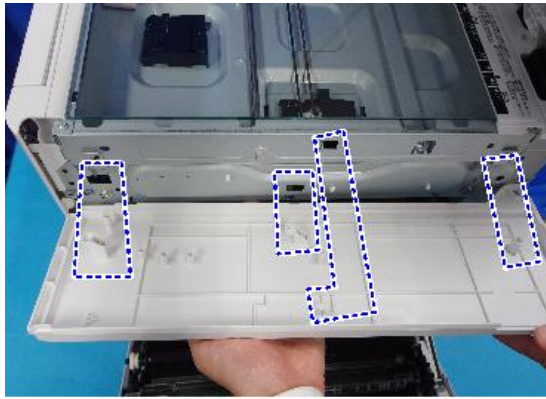

d205m4008

9. Slide the scanner unit to the right.

10. Release the FFC on the BiCU.

Unlock the connector and release it.

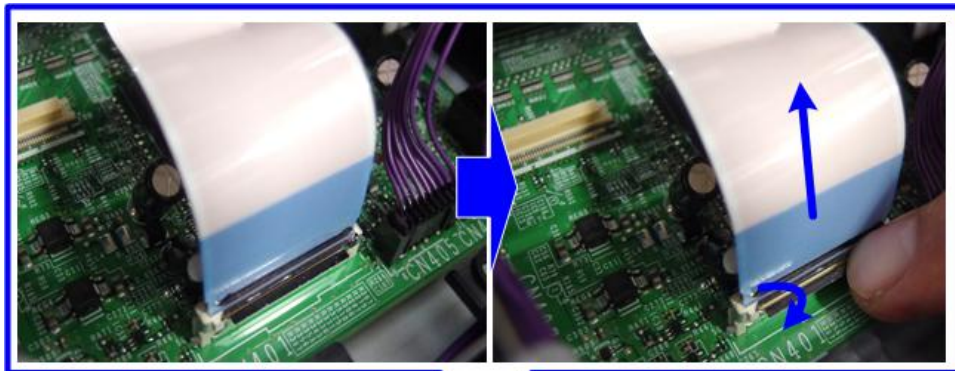

 x1

d205m4031

11. Release all the other harnesses and remove the scanner unit [A].

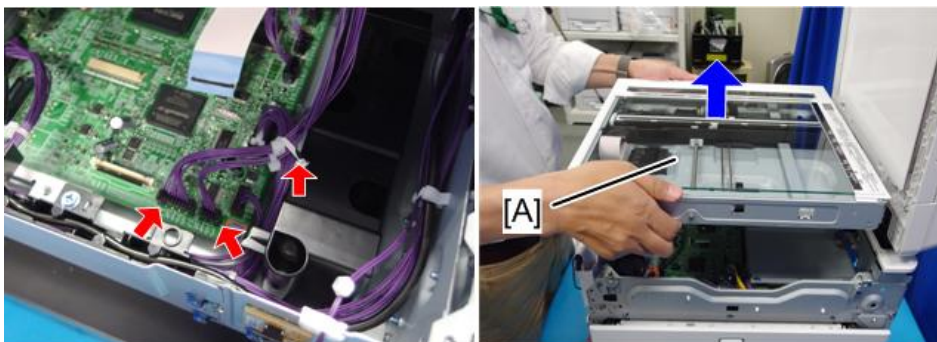

 x1,  x2

d205m4032



12. Attach the studs to the mainframe.

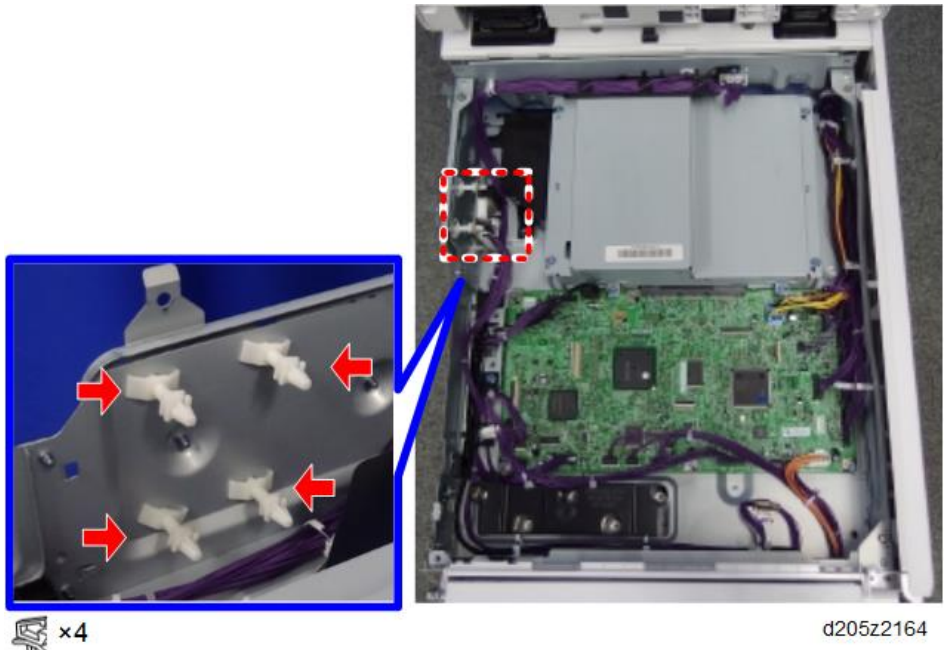

13. Install the MKB board [A].

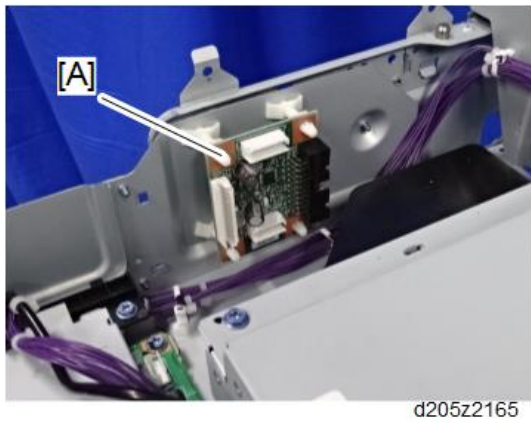

14. Attach the clamp and connect the connectors (CN112 [A] on the BiCU).

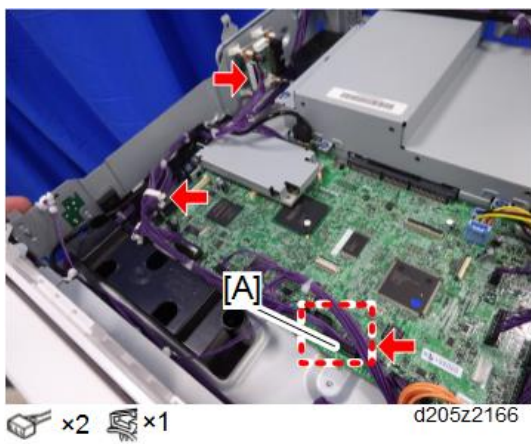

15. Cut the part [A] of the rear cover shown in the photo below.

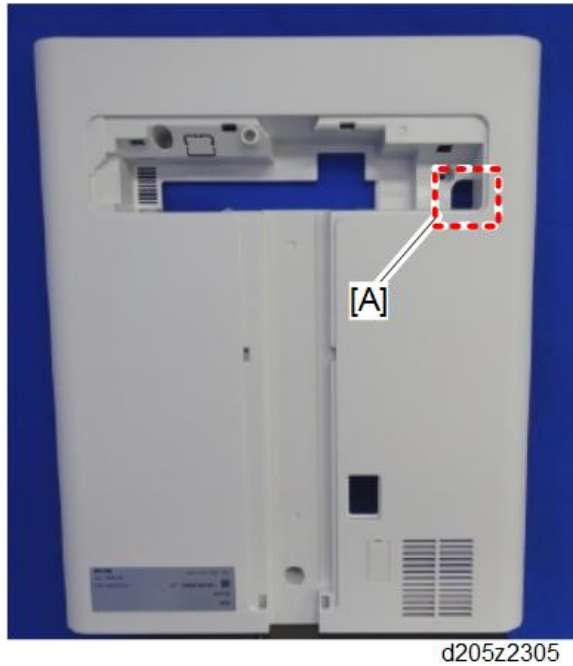

16. Connect the harness provided from third-party's counter device (20pin) and pass the harness through the opening in step 15.
17. Reassemble the machine.

## 1.11 RICOH E-SHARING BOX (D668)

Refer to "RICOH e-Sharing Box Field Service Manual".

## 1.12 CONTROLLER OPTIONS

### 1.12.1 OVERVIEW

#### ★ Important

- Always touch a grounded surface to discharge static electricity from your hands before you handle SD cards, printed circuit boards, or memory boards.

This machine has I/F card slots for optional I/F connections and SD card slots applications.

After installing an option, check that the machine can recognize it (see page 1-82 at the end of this section).

#### ***SD Card Slots***

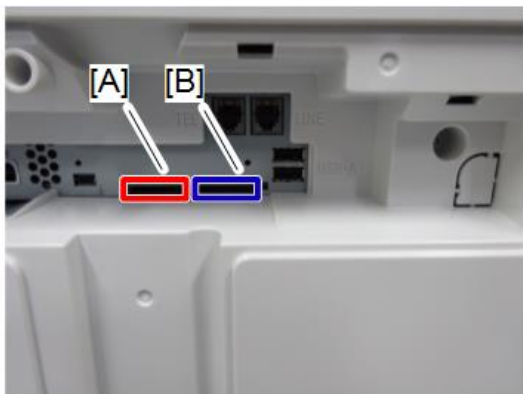

d205z2128

- Slot 1 (Left) [A] is used for optional applications (XPS Direct Print Option, Data Overwrite Security Unit, OCR Unit).
- Slot 2 (Right) [B] is used for service only (for example, updating the firmware).
- The mini USB slot to the left of the SD card slots is only for models on sale in Japan.

## USB Port



d205z2129

- These ports (lower and upper) are used for the Bluetooth Interface Unit.

## 1.12.2 SD CARD APPLI MOVE

### Overview

The service program "SD Card Appli Move" (SP5-873) allows you to move application programs from one SD card to another SD card.

If more than one application is required, the applications must be moved to one SD card with SP5873-1.

### Be very careful when you do the SD Card Appli Move procedure:

- The data necessary for authentication is transferred with the application program from an SD card to another SD card. Authentication fails if you try to use the SD card after you move the application program from one card to another card.
- Do not use the SD card if it has been used before for other purposes. Normal operation is not guaranteed when such an SD card is used.
- The original application SD card should be stored using the following procedure.

### Move Exec

The menu "Move Exec" (SP5-873-001) lets you move application programs from the original SD card to another SD card.

#### ★ Important

- Do not turn ON the write protect switch of the system SD card or application SD card on the machine. If the write protect switch is turned ON, a download error (e.g. Error Code 44) occurs during a firmware update or application merge.

1. Turn OFF the main power.

2. Remove the SD card slot cover [A].

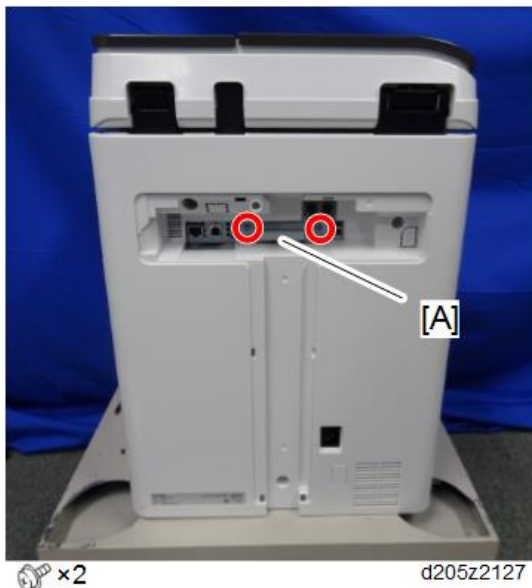

3. Make sure that a target SD card is in SD Card Slot 1 (left). The application program is moved to this SD card.
4. Insert the source SD card with the application program in SD Card Slot 2 (right). The application program is copied from this source SD card.
5. Turn ON the main power.
6. Enter the SP mode.
7. Select SP5-873-001 "Move Exec".
8. Follow the messages shown on the operation panel.
9. Turn OFF the main power.
10. Remove the source SD card from SD Card Slot 2 (right).
11. Attach the slot cover.
12. Turn ON the main power.
13. Check that the application programs run properly.

### ***Undo Exec***

"Undo Exec" (SP5-873-002) lets you move back application programs from an SD card in SD Card Slot 1 (left) to the original SD card in SD Card Slot 2 (right). You can use this program when, for example, you have mistakenly copied some programs by using Move Exec (SP5-873-001).

#### **★ Important**

- Do not turn ON the write protect switch of the system SD card or application SD card on the machine. If the write protect switch is ON, a download error (e.g. Error Code 44) occurs during a firmware upgrade or application merge.

1. Turn OFF the main power.
2. Insert the original SD card in SD Card Slot 2 (right). The application program is copied back into this card.

3. Insert the SD card with the application program in SD Card Slot 1 (left).The application program is copied back from this SD card.
4. Turn ON the main power.
5. Start the SP mode.
6. Select SP5-873-002 "Undo Exec."
7. Follow the messages shown on the operation panel.
8. Turn OFF the main power.
9. Remove the SD card from SD Card Slot 2 (right).
10. Turn ON the main power.
11. Check that the application programs run normally.
12. Make sure that the machine can recognize the option (see page 1-82 at the end of this section).

### ***Storing the SD Card***

Store the SD card at the following storage location [A] after moving the application in the SD card:

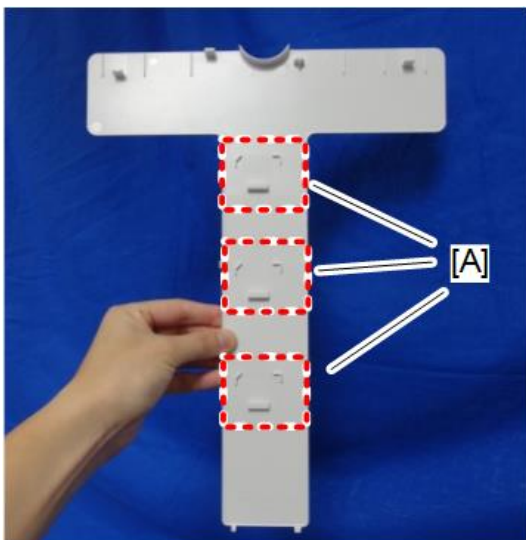

d205z2126

### 1.12.3 BLUETOOTH INTERFACE UNIT TYPE D

#### **⚠ CAUTION**

- Unplug the main machine power cord before you do the following procedure.
- Do not remove the Bluetooth unit while the main power is ON.

#### **↓ Note**

- This option cannot be installed together with IEEE 802.11 a/g/n.

1. Turn OFF the main power, and then unplug the power cable from the wall outlet.
2. Insert the Bluetooth Interface unit into the USB port [A]. (Either USB port can be used.)

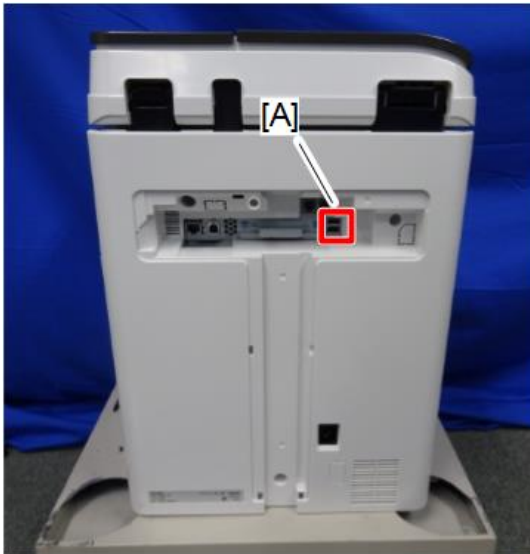

d205z2129

3. Plug the power cable and turn ON the main power.
4. Make sure that the machine can recognize the option (see page 1-82 at the end of this section).

### 1.12.4 OCR UNIT TYPE M13

1. Turn OFF the main power.
2. Remove the SD card slot cover [A].



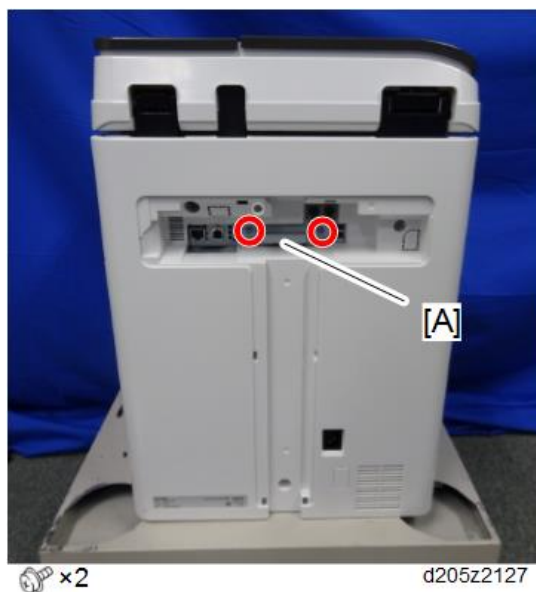

3. Insert the SD card in SD slot 1 (left) [A] with its label facing up.

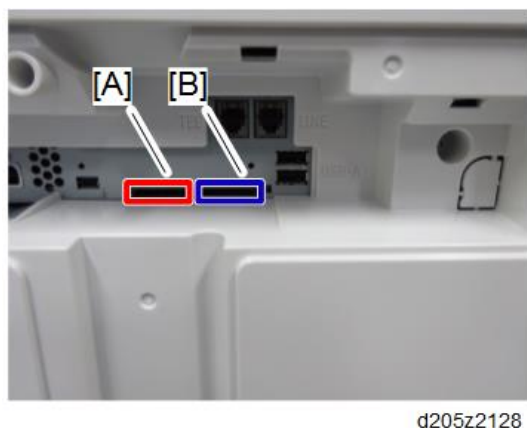

4. Turn ON the main power.
5. Press [Enter] in SP5-878-004 (Option Setup: OCR Dictionary).  
The SD card ID is saved in the NVRAM, and the ID of the MFP is saved on the SD card. The MFP and SD card are thereby linked.
6. When “operation complete” is displayed, press [Close].  
**Note**
  - You cannot install it if you use a used SD card or a write-protected SD card.
7. Turn OFF then ON the main power.
8. Press [Enter] in SP5-878-004 (Option Setup: OCR Dictionary).  
Dictionary data is copied to the HDD.  
**Note**
  - On the first run, SP5-878-004 links the SD card, and on the second run, dictionary data is copied.
9. Turn OFF the main power, and remove the SD card from the SD card slot.  
**Note**

- Keep the SD card in the SD card storage location of the MFP. The original SD card is needed in the event of a HDD malfunction.

- Return the SD card slot cover to the original position.
- Turn ON the main power.
- Press [Send File Type / Name] on the [Scanner] screen.

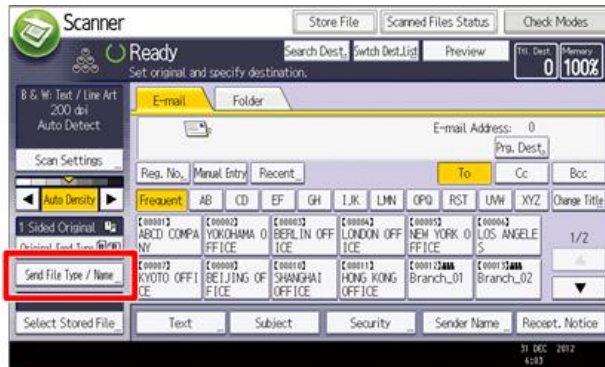

w\_d1351739

- Check if [OCR Settings] is displayed on the [Send File Type / Name] screen.



w\_d1351740

#### Note

- After installation, the OCR setting can be changed on the "OCR setting" screen.
- When setting OCR, set [OCR setting] to [Yes]. (Default setting: [No])

### **Recovery Procedure**

When this option is installed, a function is saved on the HDD, and ID information on the SD card is saved in the NVRAM. Therefore, when replacing the HDD and/or NVRAM, this option must be reinstalled.

#### **When storing the original SD card and;**

- When only the HDD is replaced;  
Reinstall using the original SD card.
- When only the NVRAM is replaced;  
When performing upload/download of NVRAM data, reinstall using the original SD card.  
When not performing upload/download of NVRAM data, order and reinstall a new SD card (service part).
- When the HDD and NVRAM are replaced simultaneously;  
Reinstall using the original SD card.

#### **If the original SD card is lost;**

Order and reinstall a new SD card (service part).

#### **Note**

- Perform reinstallation in the same way as installation.

## **1.12.5 XPS DIRECT PRINT OPTION TYPE M15**

1. Turn OFF the main power.
2. Remove the SD card slot cover [A].

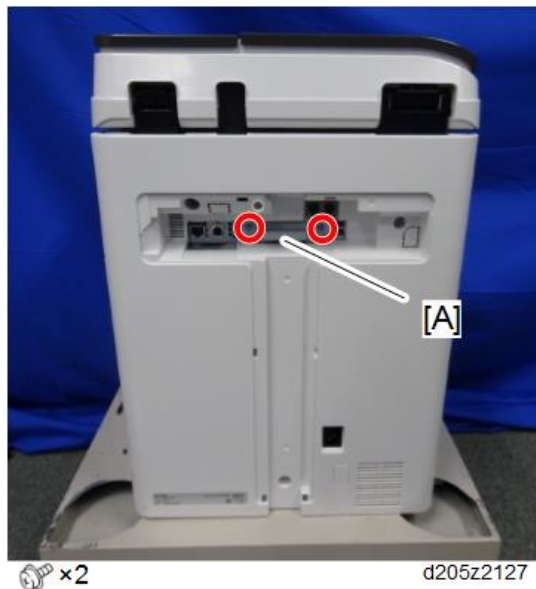

3. Insert the SD card (XPS) in SD slot 1 (left) [A] with its label facing up.

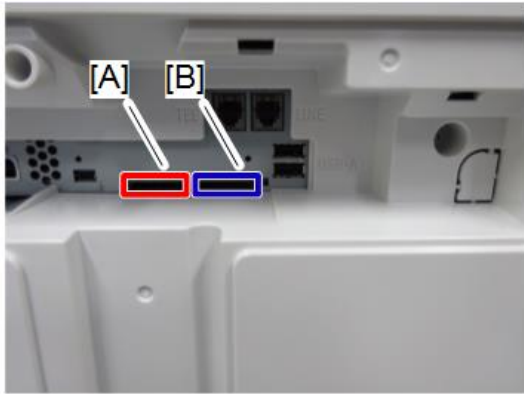

d205z2128

4. Merge the SD card contents if necessary. (page 1-72)
5. Attach the SD card slot cover.
6. Turn ON the main power.
7. Print out the “Configuration Page”, and then check if this option is correctly recognized.

User Tools > Machine Features > Printer Features > List/Test Page > Configuration Page

## 1.12.6 DATA OVERWRITE SECURITY UNIT TYPE I

### **Overview**

This option should be installed only for the customer who requires the **CC certified Data Overwrite Security function**.

The function of this option is completely the same as the Data Overwrite Security in Security Functions, which is standard on this machine.

### **Before You Begin the Procedure**

1. Confirm that the Data Overwrite Security unit SD card is the correct type for the machine. The correct type for this machine is **"Type I"**.

#### **★ Important**

- **If you install any version other than "Type I", you have to replace the NVRAM and do this installation procedure again.**

2. Make sure that the following settings are not at their factory default values:

- Supervisor login password
- Administrator login name
- Administrator login password

If any of these settings is a factory default value, tell the customer these settings must be changed before you do the installation procedure.

3. Make sure that "Admin. Authentication" is ON.

[System Settings] – [Administrator Tools] – [Administrator Authentication Management] - [Admin. Authentication]

If this setting is OFF, tell the customer this setting must be ON before you do the installation procedure.

4. Make sure that "Administrator Tools" is enabled (selected).

[System Settings] – [Administrator Tools] – [Administrator Authentication Management] - [Available Settings]

If this setting is disabled (not selected), tell the customer this setting must be enabled (selected) before you do the installation procedure.

### **Seal Check and Removal**

#### **⚠ CAUTION**

- You must check the box seals to make sure that they are not removed after the items have been sealed in the box at the factory before you do the installation.

1. **Check the box seals [A] on each corner of the box.**

- Make sure that a tape is attached to each corner.
- The surfaces of the tapes must be blank. If you see "VOID" on the tapes, do not install the components in the box.

2. If the surfaces of the tapes do not show “VOID”, remove them from the corners of the box.
3. You can see the “VOID” marks [B] when you remove each seal. In this condition, they cannot be attached to the box again.

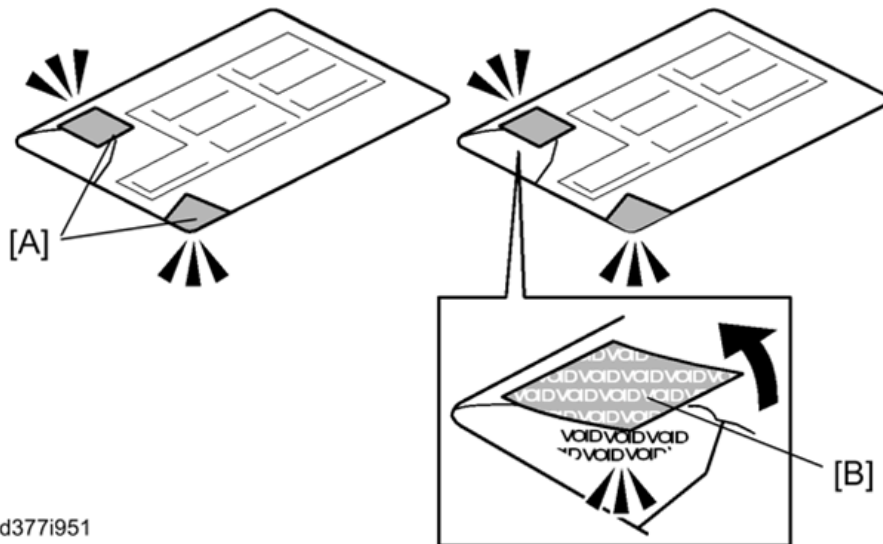

d377i951

### Installation Procedure

1. Turn OFF the main power.
2. Remove the SD card slot cover [A].

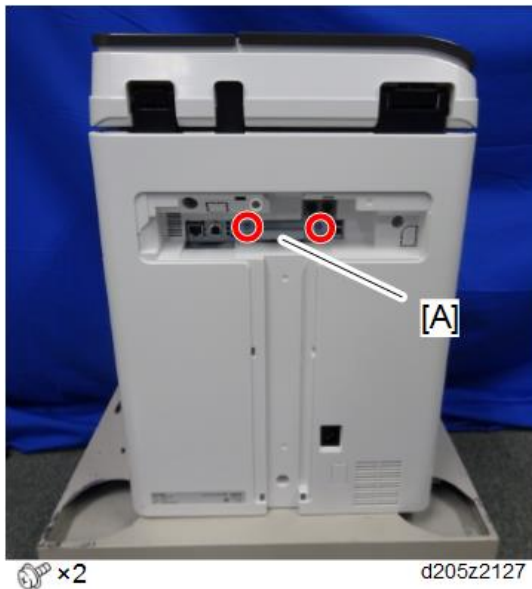

3. Insert the SD card (DataOverwriteSecurity Unit) in SD slot 1 (left) [A] with its label facing up. Then push it slowly into SD slot 1 until you hear a click.

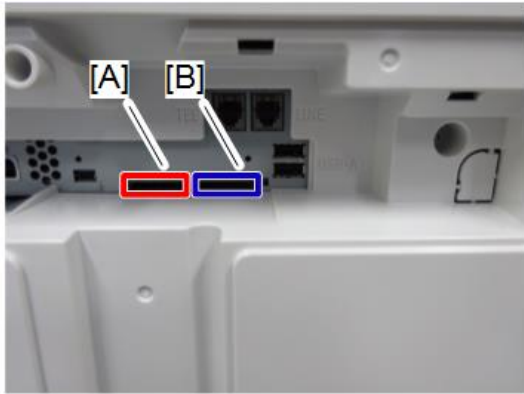

d205z2128

4. Execute SP5-878-001 to install (initialize) the application.

### 1.12.7 CHECK ALL CONNECTIONS

1. Plug in the power cord. Then turn ON the main power.
2. Enter the printer user mode. Then print the configuration page.

User Tools → Machine Features → Printer Features → List Test Print → Configuration Page

All installed options are shown in the "System Reference" column.



## 1.13 SECURITY SETTINGS

### 1.13.1 SECURITY FUNCTION INSTALLATION

#### ★ Important

- If the “Enhanced Security HDD Option Type M10” is installed at the same time of the main machine’s installation, do not execute these settings described below. When the “Enhanced Security HDD Option Type M10” and security functions (Data Overwrite Security and HDD Encryption Unit) are activated in the same machine, the function of the “Enhanced Security HDD Option” is not guaranteed.

The machine contains the Security functions (Data Overwrite Security and HDD Encryption unit) in the controller board.

If you are installing a new machine, it is recommended to activate the Data Overwrite Security and HDD Encryption by selecting "Format All Data" from “System Settings” on the operation panel.

#### ↓ Note

- This method is recommended because there is no user data on the hard drive yet (Address Book data, image data, etc.).

If the customer wishes to activate the Data Overwrite Security and HDD Encryption unit on a machine that is already running, it is recommended to activate the unit by selecting "All Data" from “System Settings” on the operation panel.

#### ★ Important

- Selecting "All Data" will preserve the data that has already been saved to the HDD. (If "Format All Data" is selected, all user data saved to the HDD up to that point will be erased).

Immediately after encryption is enabled, the encryption setting process will take several minutes to complete before you can begin using the machine.

#### ↓ Note

- If encryption is enabled after data has been stored on the HDD, or of the encryption key is changed, this process can take up to three and a half hours or more.

The machine cannot be operated while data is being encrypted.

Once the encryption process begins, it cannot be stopped.

Make sure that the machine's main power is not turned OFF while the encryption process is in progress.

If the machine's main power is turned OFF while the encryption process is in progress, the HDD will be damaged and all data on it will be unusable.

Print the encryption key and keep the encryption key (which is printed as a paper sheet).

Keep the encryption key in a safe place. If the encryption key is lost and is needed, the controller board, HDD and NVRAM must all be replaced at the same time.

 **Note**

- "NVRAM" mentioned in here means the NVRAM on the Controller Board.
- "NVRAM" or EEPROM on the BiCU has nothing to do with this.

Please use the following procedure when the Data Overwrite Security and HDD Encryption are reinstalled.

## 1.13.2 DATA OVERWRITE SECURITY

### *Before You Begin the Procedure*

**1. Make sure that the following settings (1) to (3) are not at their factory default values.**

- (1) Supervisor login password
- (2) Administrator login name
- (3) Administrator login password

If any of these settings is at a factory default value, tell the customer these settings must be changed before you do the installation procedure.

**2. Make sure that “Admin. Authentication” is on.**

[System Settings] -> [Administrator Tools] -> [Administrator Authentication Management] -> [Admin. Authentication]

If this setting is off, tell the customer this setting must be on before you do the installation procedure.

**3. Make sure that “Administrator Tools” is enabled (selected).**

[System Settings] -> [Administrator Tools] -> [Administrator Authentication Management] -> [Available Settings]

If this setting is disabled (not selected), tell the customer this setting must be enabled (selected) before you do the installation procedure.

### *Using Auto Erase Memory*

The Auto Erase Memory function can be enabled by the following procedure.

- 1. Log in as the machine administrator from the control panel.**
- 2. Press [System Settings].**
- 3. Press [Administrator Tools].**
- 4. Press [Next] three times.**
- 5. Press [Auto Erase Memory Setting].**

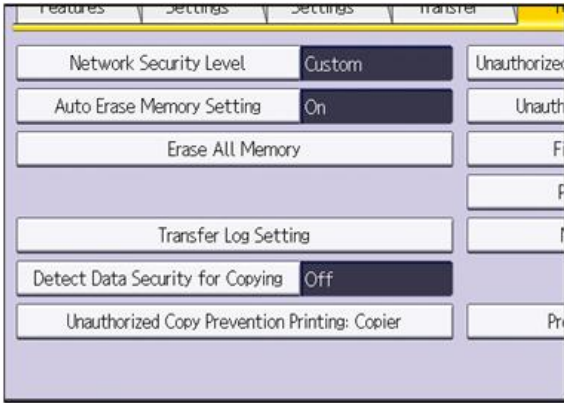

w\_d1822517

6. Press [On].
7. Select the method of overwriting.
  - If you select [NSA] or [DoD], proceed to step 10.
  - If you select [Random Numbers], proceed to step 8.
8. Press [Change].
9. Enter the number of times that you want to overwrite using the number keys, and then press [#].
10. Press [OK]. Auto Erase Memory is set.
11. Log out.
12. Check the display and make sure that the overwrite erase icon appears.
13. Check the overwrite erase icon.

The icon [1] is lit when there is temporary data to be overwritten, and blinks during overwriting.

The icon [2] is lit when there is no temporary data to be overwritten.

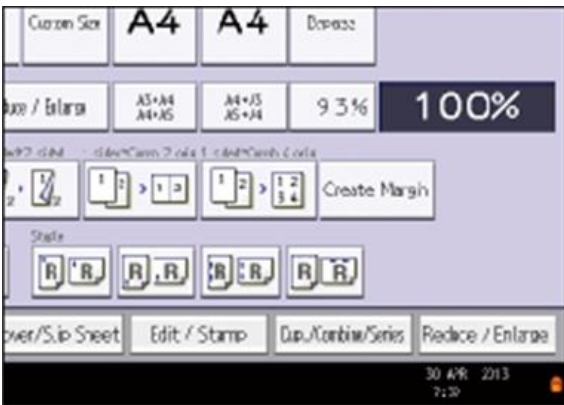

w\_d1822516

	Icon [1]	This icon is lit when there is temporary data to be overwritten, and blinks during overwriting.
--	----------	---

	Icon [2]	This icon is lit when there is no temporary data to be overwritten.
---	----------	---

### 1.13.3 HDD ENCRYPTION

#### ***Before You Begin the Procedure:***

1. **Make sure that the following settings (1) to (3) are not at the factory default settings.**

- (1) Supervisor login password
- (2) Administrator login name
- (3) Administrator login password

If any of these settings is at a factory default value, tell the customer these settings must be changed before you do the installation procedure.

2. **Confirm that "Admin. Authentication" is on: [User tools/Counter] key - [System Settings] - [Administrator Tools] - [Administrator Authentication Management] - [Admin. Authentication] - [On]**

If this setting is off, tell the customer that this setting must be on before you can do the installation procedure.

3. **Confirm that "Administrator Tools" is selected and enabled.**

[User tools/Counter] key - [System Settings] - [Administrator Tools] - [Administrator Authentication Management] - [Available Settings]

"Available Settings" is not displayed until step 2 is done.

If this setting is not selected, tell the customer that this setting must be selected before you can do the installation procedure.

#### ***Enable Encryption Setting***

Machine Data Encryption Settings can be enabled by the following procedure.

#### **★ Important**

- **When setting up encryption, specify whether to start encryption after deleting data (initialize) or encrypt and retain existing data. If data is retained, it may take some time to encrypt it.**

1. **Turn ON the main power.**
2. **Log in as the machine administrator from the control panel.**
3. **Press [System Settings].**
4. **Press [Administrator Tools].**
5. **Press [Next] three times.**
6. **Press [Machine Data Encryption Settings].**

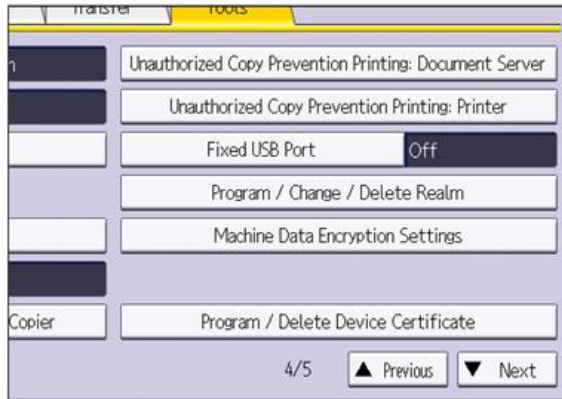

w\_d1822518

### 7. Press [Encrypt].

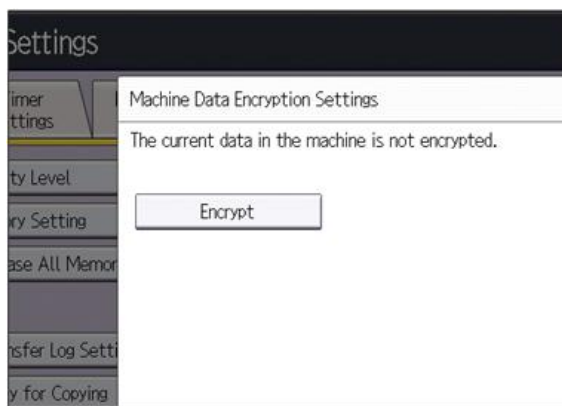

w\_d1822519

### 8. Select the data to be carried over to the HDD and not be reset.

To carry all of the data over to the HDD, select [All Data].

To carry over only the machine settings data, select [File System Data Only].

To reset all of the data, select [Format All Data].

### 9. Select the backup method.

If you have selected [Save to SD Card], load an SD card into the media slot on the side of the control panel and press [OK] to back up the machine's data encryption key.

If you have selected [Print on Paper], press the [Start] key. Print out the machine's data encryption key.

### 10. Press [OK].

### 11. Press [Exit].

### 12. Press [Exit].

### 13. Log out.

### 14. Turn OFF then ON the main power.

The machine will start to convert the data on the memory after you turn ON the main power.

Wait until the message "Memory conversion complete. Turn the main power switch off."

appears, and then turn OFF the main power again.

### Check the Encryption Settings

## Security Settings

1. Press [User tools/Counter].
2. Press [System Settings].
3. Press [Administrator Tools].
4. Press [Machine Data Encryption Settings].
5. Confirm whether the encryption has been completed or not on this display.

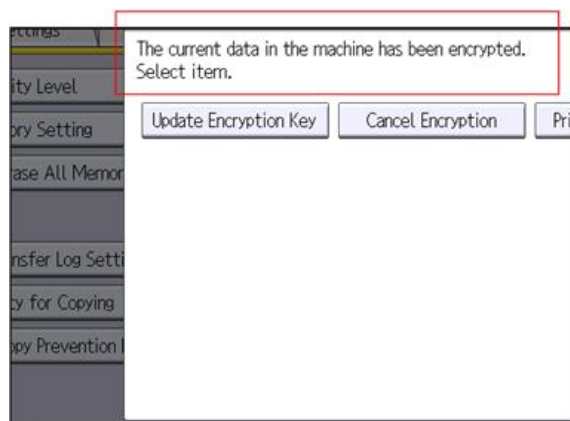

w\_d1822520

### ***Backing Up the Encryption Key***

The encryption key can be backed up. Select whether to save it to an SD card or to print it.

#### **★ Important**

- The encryption key is required for data recovery if the machine malfunctions. Be sure to store the encryption key safely for retrieving backup data.

1. Log in as the machine administrator from the control panel.
2. Press [System Settings].
3. Press [Administrator Tools].
4. Press [Next] three times.
5. Press [Machine Data Encryption Settings].
6. Press [Print Encryption Key].



w\_d1822515

7. Select the backup method.

If you have selected [Save to SD Card], load an SD card into the media slot on the side of the control panel and press [OK]; once the machine's data encryption key is backed up, press

[Exit].

If you have selected [Print on Paper], press the [Start] key. Print out the machine's data encryption key.

8. Press [Exit].
9. Log out.

## ***Encryption Key Restoration***

### **How to restore the old encryption key to the machine**

The following message appears after the controller board is replaced. In such a case, it is necessary to restore the encryption key to the new controller board.

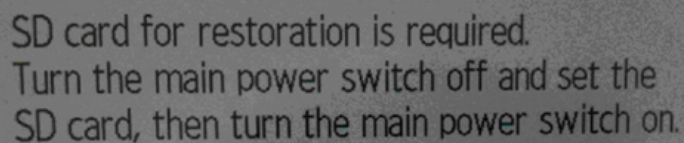

SD card for restoration is required.  
Turn the main power switch off and set the  
SD card, then turn the main power switch on.

d1420101

To do this, follow the procedure below.

1. Prepare an SD card that has been initialized in FAT16 format.
2. Using a PC, create a folder in the SD card and name it "restore\_key".
3. Create a folder in the "restore\_key" folder and name it the same as machine's serial number, "xxxxxxxxxx" (11 digits).
4. Create a text file called "key\_xxxxxxxxxx.txt" and save it in the "xxxxxxxxxx" folder.  
Write the encryption key in the text file.

/restore\_key/xxxxxxxxxx/key\_xxxxxxxxxx.txt

#### **Note**

- Ask an Administrator to enter the encryption key. The key has already been printed out by the user and may have been saved in the "key\_xxxxxxxxxx.txt" file. (The function of back-up the encryption key to the SD card directly is provided 11A products or later.)

5. Turn ON the main power.
6. Confirm that a message is displayed on the LCD telling to insert the SD card that contains the encryption key.
7. Turn OFF the main power.
8. Insert the SD card that contains the encryption key into SD card slot 2 (the lower slot).
9. Turn ON the main power.

#### **Note**

- The machine will automatically restore the encryption key to the flash memory on the controller board.

10. Turn OFF the main power when the machine has returned to normal status.
11. Remove the SD card from SD card slot 2.



### How to do a forced start up with no encryption key

If the encryption key back-up has been lost, follow the procedure below to do a forced start-up.

**★ Important**

- The HDD will be formatted after the forced start-up.
- Encrypted data will be deleted.
- User settings will be cleared.

1. Prepare an SD card.
2. Create a directory named “restore\_key” inside the root directory of the SD card. Then, save the “nvram\_key.txt” file using the following name:

/restore\_key/nvram\_key.txt

3. Create a text file and write "nvclear".

**★ Important**

- Write this string at the head of the file.
  - Use all lower-case letters.
  - Do not use quotation marks or blank spaces.
  - It is judged that a forced start has been selected when the content of "nvclear" is executed and the machine shifts to the alternate system (forced start).
4. Confirm that a message is displayed on the LCD telling to insert the SD card that contains the encryption key.
  5. Turn OFF the main power.
  6. Insert the SD card that contains the encryption key into SD card slot 2 (the lower slot).
  7. Turn ON the main power.  
The machine automatically clear the HDD encryption.
  8. Turn OFF the main power when the machine has returned to normal status.
  9. Remove the SD card from SD card Slot 2.
  10. Turn ON the main power.
  11. Execute SP5-801-xx (Exclude SP5-801-001: All Clear and SP5-801-002: Engine), and SP5-846-046: address book.
  12. Set necessary user settings in User Tools key.

## 1.14 @REMOTE SETTINGS

### Note

- Prepare and check the following check points before you visit the customer site. For details, ask the @Remote key person.

### 1.14.1 SETTING PROCEDURE

#### Check points before making @Remote settings

- The value of SP5-816-201 ([Remote Service]-[Regist Status]) to "0".  
0: Neither the registered device by the external nor embedded RCG device is set.
- Print the SMC with SP5-990-002 and then check if a device ID2 (SP5-811-003) must be correctly programmed.
  - 6 spaces must be put between the 3-digit prefix and the following 8-digit number (e.g. xxx\_\_\_\_xxxxxxxx).
  - ID2 (SP5-811-003) and the serial number (SP5811-001) must be the same (e.g. ID2: A01\_\_\_\_23456789 = serial No. A0123456789)
- The following settings must be correctly programmed.
  - Proxy server IP address (SP5-816-063)
  - Proxy server Port number (SP5-816-064)
  - Proxy User ID (SP5-816-065)
  - Proxy Password (SP5-816-066)

#### 4. Get a Request Number

#### Execute the @Remote Settings

- Enter the SP mode.
- Input the Request number which you have obtained from @Remote Center GUI, and then enter [OK] with SP5-816-202 ([Remote Service]-[Letter Number]).
- Confirm the Request number, and then click [EXECUTE] with SP5-816-203 ([Remote Service]-[Confirm Execute]).
- Check the confirmation result with SP5-816-204 ([Remote Service]-[Confirm Result]).

Value	Meaning	Solution/ Workaround
0	Succeeded	-
3	Communication error (proxy enabled)	Check the network condition.
4	Communication error (proxy disabled)	Check the network condition.

Value	Meaning	Solution/ Workaround
5	Proxy error (authentication error)	Check Proxy user name and password.
6	Communication error	Check the network condition.
8	Other error	See "SP5-816-208 Error Codes" below this.
9	Request number confirmation executing	Processing... Please wait.
11	Already registered	-
12	Parameter error	-
20	Dial-up authentication error	* These errors occur only in the modems that support @Remote.
21	Answer tone detection error	
22	Carrier detection error	
23	Invalid setting value (modem)	
24	Low power supply current	
25	unplugged modem	
26	Busy line	

5. **Make sure that the screen displays the Location Information with SP5-816-205 only when it has been input at the Center GUI.**
6. **Execute the registration with SP5-816-206 ([Remote Service]-[Register Execute]).**
7. **Check the registration result with SP5-816-207 ([Remote Service]-[Register Result]).**

Value	Meaning	Solution/ Workaround
0	Succeeded	-
1	Request number error	Check the request number again.
2	Already registered	Check the registration status.
3	Communication error (proxy enabled)	Check the network condition.

Value	Meaning	Solution/ Workaround
4	Communication error (proxy disabled)	Check the network condition.
5	Proxy error (Authentication error)	Check Proxy user name and password.
8	Other error	See "SP5-816-208 Error Codes" below this.
9	Request number confirmation executing	Processing... Please wait.
11	Already registered	-
12	Parameter error	-
20	Dial-up authentication error	* These errors occur only in the modems that support @Remote.
21	Answer tone detection error	
22	Carrier detection error	
23	Invalid setting value (modem)	
24	Low power supply current	
25	unplugged modem	
26	Busy line	

### 8. Exit the SP mode.

## 1.14.2 SP5-816-208 ERROR CODES

Caused by Operation Error, Incorrect Setting

Code	Meaning	Solution/ Workaround
-12002	Inquiry, registration attempted without acquiring Request No.	Obtain a Request Number before attempting the Inquiry or Registration.
-12003	Attempted registration without execution of a confirmation and no previous registration.	Perform Confirmation before attempting the Registration.
-12004	Attempted setting with illegal entries for certification and ID2.	Check ID2 of the mainframe.
-12005	@Remote communication is prohibited. The device has an Embedded RC gate-related problem.	Make sure that "Remote Service" in User Tools is set to "Do not prohibit".
-12006	A confirmation request was made after the confirmation had been already completed.	Execute registration.
-12007	The request number used at registration was different from the one used at confirmation.	Check Request No.
-12008	Update certification failed because mainframe was in use.	Check the mainframe condition. If the mainframe is in use, try again later.
-12009	The ID2 in the NVRAM does not match the ID2 in the individual certification.	Check ID2 of the mainframe.
-12010	The certification area is not initialized.	Initialize the certification area.

## Error Caused by Response from GW URL

Code	Meaning	Solution/ Workaround
-2385	Other error	
-2387	Not supported at the Service Center	
-2389	Database out of service	
-2390	Program out of service	
-2391	Two registrations for the same mainframe	Check the registration condition of the mainframe
-2392	Parameter error	
-2393	External RCG not managed	
-2394	Mainframe not managed	
-2395	Box ID for external RCG is illegal.	
-2396	Mainframe ID for external RCG is illegal.	
-2397	Incorrect ID2 format	Check the ID2 of the mainframe.
-2398	Incorrect request number format	Check the Request No.

## 1.15 OPERATION GUIDANCE FOR USERS

Function/Operation	Instruction to provide
Basic machine functions, operations	<ul style="list-style-type: none"> <li>▪ How to load the toner bottle</li> <li>▪ How to load paper and other consumables/supplies</li> <li>▪ How to turn ON or OFF the main power</li> <li>▪ How to clear paper jams</li> <li>▪ How to program, modify, and delete Address Book entries</li> <li>▪ How to customize the UI and home screen</li> <li>▪ Overview of machine options/peripherals</li> <li>▪ How to take the proper action for SC errors (clearing the error, contacting service and support, etc.), how to interpret @Remote notifications</li> <li>▪ Important notes to keep in mind whenever moving the machine</li> <li>▪ Product limitations</li> </ul>
Copier	<ul style="list-style-type: none"> <li>▪ Basic Copier operations</li> <li>▪ How to load an original in the ARDF or place it on the exposure glass for scanning</li> <li>▪ How to use thick paper and other specialized paper/media</li> <li>▪ How to configure the Copier main screen (duplex/simplex, auto color selection, User Codes, etc.)</li> <li>▪ Basic Document Server operations</li> </ul>
Fax (when installed)	<ul style="list-style-type: none"> <li>▪ How to send a fax (Memory Transmission, Direct Transmission)</li> </ul>
Printer (when installed)	<ul style="list-style-type: none"> <li>▪ How to install printer drivers (using the recommended method)</li> <li>▪ How to connect to a PC (performing the port settings)</li> <li>▪ How to print out a test page</li> <li>▪ Overview of various settings inside each tab in the printer driver (e.g. duplex printing)</li> </ul>
Scanner (when installed)	<ul style="list-style-type: none"> <li>▪ How to install printer drivers (using the recommended method)</li> <li>▪ How to connect to a PC and perform a test scan</li> </ul>



# PREVENTIVE MAINTENANCE

REVISION HISTORY		
Page	Date	Added/Updated/New
		None



## 2. PREVENTIVE MAINTENANCE

### 2.1 PREVENTIVE MAINTENANCE TABLES

See “Appendices” for the Preventive Maintenance Tables

### 2.2 PM/YIELD PARTS SETTINGS

#### 2.2.1 SET-UP PROCEDURE FOR REPLACING THE PM/YIELD PARTS

1. Enter the SP mode.
2. Get the SMC log data using one of the following ways:
  - a) Execute SP5-990-001 to print SMC log data.
  - b) Execute SP5-992-001 (SMC List Card Save Function) to save SMC log data to an SD card.
3. In the SMC data, look at the values of the counters in SP7-621-002 and/or -115, to determine what parts should be replaced.  
Refer to the SP table and PM tables in Appendices.
4. The following parts require the manual new unit detection setting by a predetermined SP. See the table below:

Item	SP	Description
120K Parts	SP2-701-108	To detect a new part/unit for these items automatically, set the value of this SP to “1”. Turn OFF then ON the main power to apply the setting.

#### ⬇ Note

- 120K parts includes the parts as shown below:  
Hot roller, Pressure roller, Hot roller stripper pawls, Hot roller bearing, Pressure roller bearing

 **Note**

- The PCDU detects a new unit automatically. Other parts require the manual new unit detection setting with the above SPs.
5. **If the value of SP2-701-108 is “0”, clear the counter for the 120K parts by SP7-622-115 ([PM Counter Reset]-[120K parts]).**
  6. **Turn OFF the main power.**
  7. **Perform the parts replacement.**
  8. **Turn ON the main power.**
  9. **On the operation panel, look at the PM counters of the parts that you replaced, to make sure that these counters were reset to 0. (The PM counter values are in SP7-621-002, and/or -115.) If the PM counter for a unit is not reset, repeat steps 4, 5, and 7.**
  10. **Exit the SP mode.**
  11. **Check if the sample image has been copied correctly.**

# REPLACEMENT AND ADJUSTMENT

REVISION HISTORY		
Page	Date	Added/Updated/New
		None



---

## 3. REPLACEMENT AND ADJUSTMENT

### 3.1 NOTES ON THE MAIN POWER SWITCH

#### 3.1.1 PUSH SWITCH

The main power button of this machine has been changed to a push-button switch (push button) from the conventional rocker switch. The push switch has characteristics and specifications different from the rocker switch. Care must be taken when replacing and adjusting parts.

#### ***Characteristics of the Push Switch (DC Switch)***

**Power is supplied to the machine even when the main power switch is turned OFF.**

The push switch in this machine uses DC (direct current). Therefore, if the AC power cord is connected to an electrical outlet, power is supplied to the controller board, the operation unit and other modules even when the main power is turned OFF. When replacing the controller board and the operation unit in this state, not only these boards, it will damage other electrical components.

In 100V models, only one of the AC lines for the fusing unit is shut off when you turn OFF the main power; the other line carries current even when you turn off the main power switch.

So, when performing maintenance work such as replacing parts, in addition to turning OFF the main power with the push switch, always unplug the AC power cord.

**When you disconnect the power cord from the AC wall outlet, inside the machine there is still residual charge.**

When you disconnect the power cord from the AC wall outlet, inside the machine for a while there is still residual charge. Therefore, if you remove boards in this state, it can cause a blown fuse or memory failure.

- How to remove the residual charge inside the machine

After you unplug the power cord from the AC wall outlet, in order to remove the residual charge from inside the machine, be sure to press the main power switch. Thus, the charge remaining in the machine is released, and it is possible to remove boards.

**When you reconnect the AC power cord into an AC wall outlet, the machine will start automatically.**

In order to remove the residual charge, push the main power switch while you disconnect the AC power cord. At that time, the power ON flag inside the machine is set. Therefore, after you finish work on the machine and reconnect the power cord to the AC, even if you do not press the main power switch, the machine will start automatically and the moving parts will begin to move. **When working on moving parts, be careful that fingers or clothes do not get caught.**



**Note**

- Automatic restart deals with cases when you accidentally unplugged the AC power cord or unexpected power outages. By keeping the power flag ON, after the resumption of power, the machine will start up automatically.

In rare cases, when you reconnect the AC power cord to a power outlet, the machine does not start automatically. In this case, the machine has not failed. The cause is due to the timing of releasing the residual charge. If you press the main power switch while the residual charge was already released, the power ON flag will not be set. At this time, start the machine manually by pressing the main power switch.

### **Shutdown Method (How to Turn OFF the Main Power)**

1. **Press the main power switch [A] on the machine.**

**Note**

- When the shutdown is complete, the LED on the operation panel is turned OFF.



d205z4010

2. **Disconnect the power cord.**

**Note**

- Wait three minutes to access the internal parts such as the controller board.

**CAUTION**

- If some LEDs on any of the boards are blinking or lit, current is still flowing.
- After the shutdown process, the main power is turned OFF automatically.

**Note**

- **How to start from shutdown:**  
To start the machine, press the main power switch. However, if you press the main power switch between the beginning and the end of a shutdown, the machine will not start.

## **Forced Shutdown**

In case normal shutdown does not complete for some reason, the machine has a forced shutdown function.

To make a forced shutdown, press and hold the main power switch for 6 seconds.

In general, do not use the forced shutdown.

### **Important**

- **Forced shutdown may damage the hard disk and memory, and can cause damage to the machine. Use a forced shutdown only if it is unavoidable.**

## **3.2 BEFOREHAND**

### **CAUTION**

- Turn OFF the main power and unplug the machine power cord before starting the following procedures. Otherwise, it may result in an electric shock or a malfunction.
- After replacing, make sure that all removed harnesses are connected up again and secured in their clamps.

### **Note**

- Some illustrations may differ from the actual machine.

In this chapter, a step that has only a part name means that you remove the part.

For example:

#### **1. Front cover**

means

#### **1. Remove the front cover.**

### 3.3 SPECIAL TOOLS AND LUBRICANTS

No.	Part Number	Description	Q'ty	Unique/Common
1	B6455020	SD Card	1	Common
2	VSSG9006	Grease – G-1077	1	Unique
4	A2929500	Test Chart – S5S (10pcs/set)	1	Common
5	B6455030	SD-CARD:SERVICE PARTS:2GB:ASS'Y	1	Common
6	52039502	Silicone Grease G-501	1	Common

### 3.4 QUICK REFERENCE FOR REMOVING MAJOR UNITS

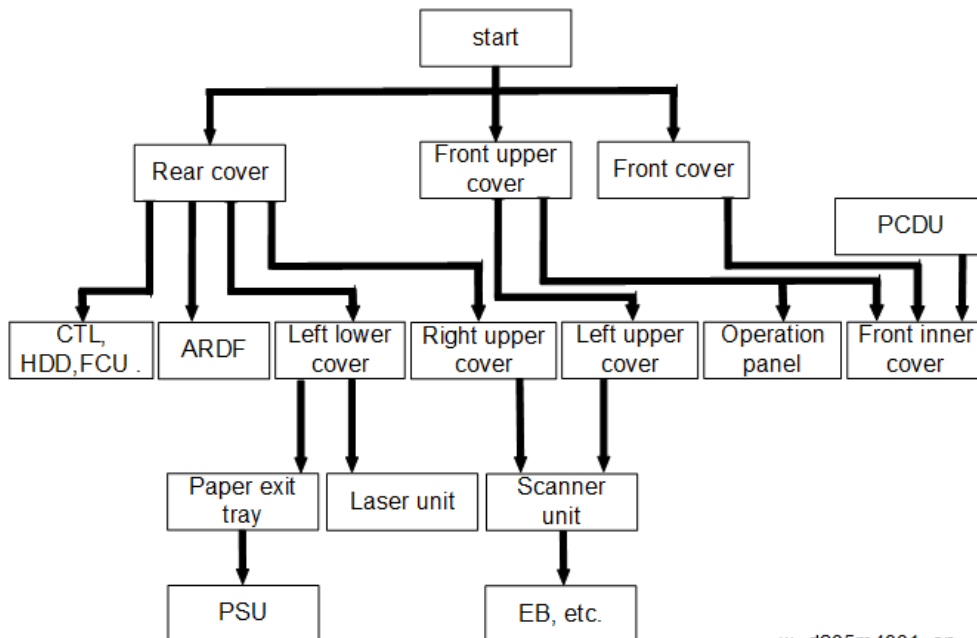

w\_d205m4001\_en

## 3.5 EXTERIOR COVERS

### 3.5.1 REAR COVER

#### 1. T-shaped Cover [A]



#### 2. Screws of the rear cover [A]

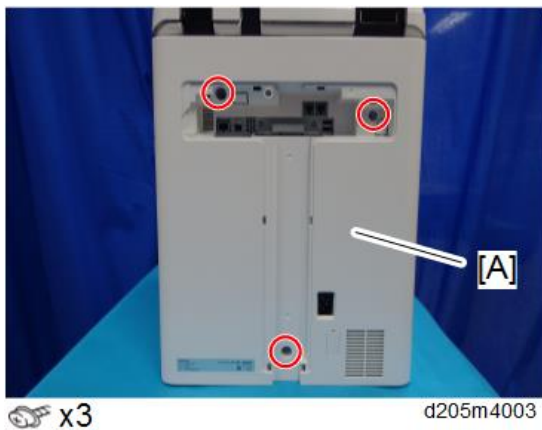

#### 3. Open the right cover.

#### 4. Rear Cover [A] (tab x 2)



#### Note

- Be careful not to damage the tabs at the rear of the left cover when removing or installing the rear cover.

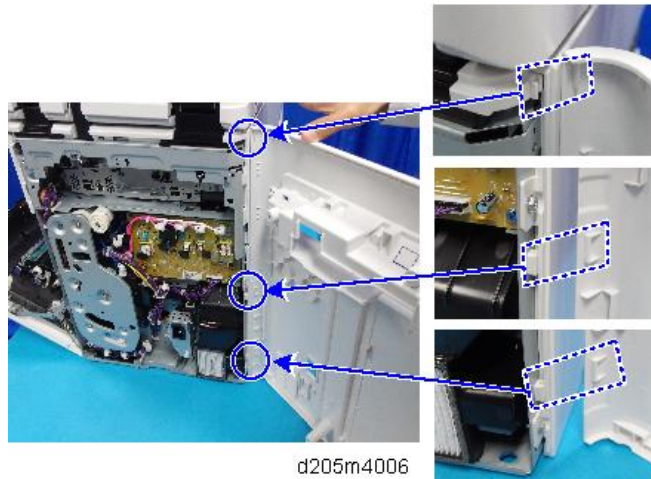

### 3.5.2 RIGHT UPPER COVER

1. Rear Cover (page 3-5)
2. Slide and remove the right upper cover [A].



 x2

 **Note**

- Be careful not to damage the positioning boss and the tabs on the cover when you remove or install.

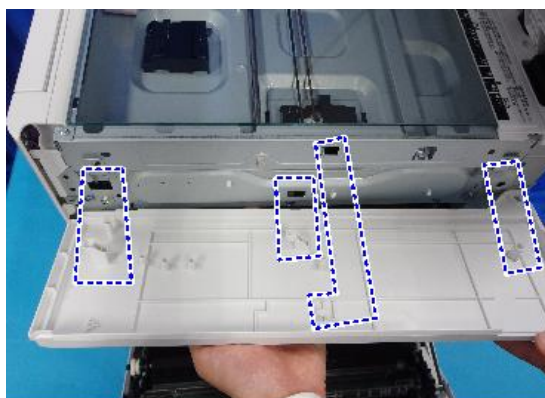

### 3.5.3 FRONT UPPER COVER

1. Open the front cover and remove the cover [A].

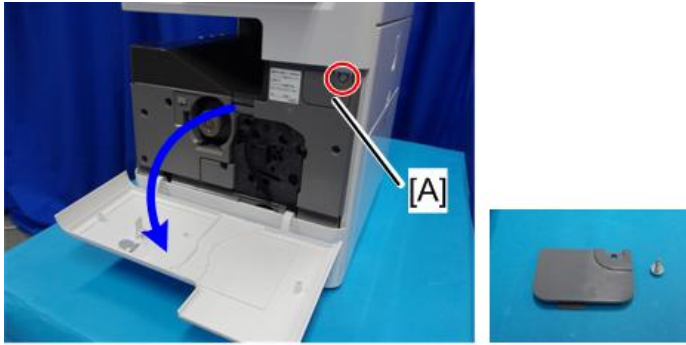

 x1

d205m4010

2. Front Upper Cover [A]

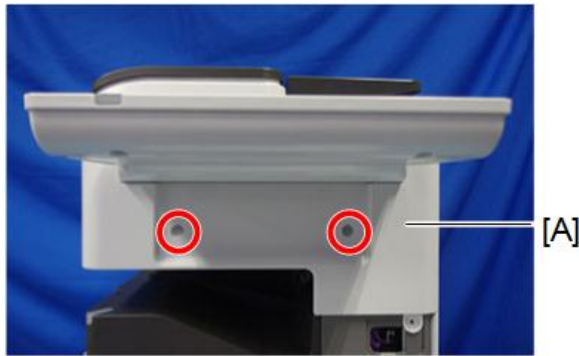

 x2

d205z5018



### 3.5.4 LEFT UPPER COVER

1. Front Upper Cover (page 3-7)
2. Slide and remove the left upper cover [A]. (Positioning Boss [B])

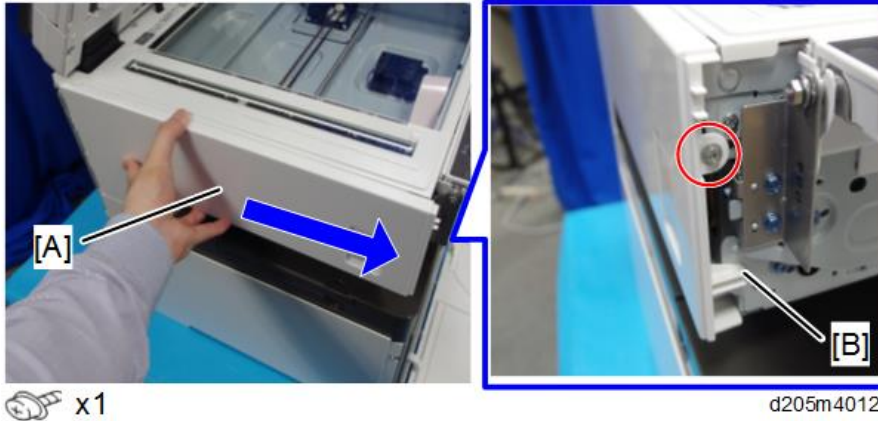

**Note**

- Be careful not to damage the two tabs at the rear when removing or installing.

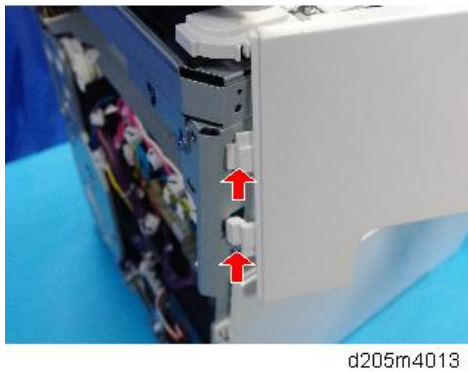



### 3.5.5 LEFT LOWER COVER

1. Rear Cover (page 3-5)
2. Pull the paper feed tray and open the front cover.

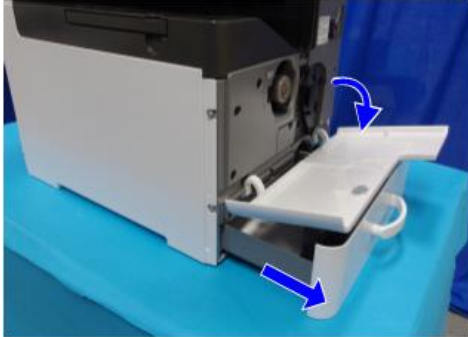

d205z4014

3. Left lower cover [A].

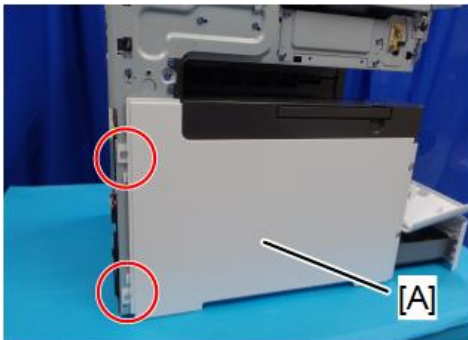
 x2

d205m4014

#### ⓘ Note

- To remove the left lower cover [A], slide to rear and be careful not to damage the positioning boss [B] and tabs.

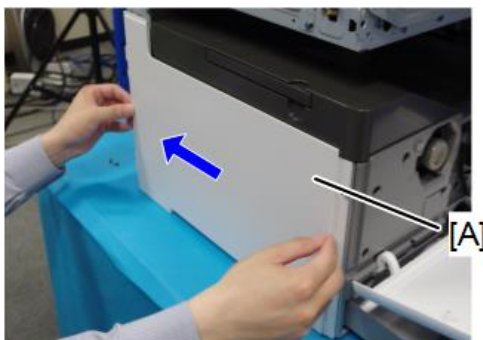

d205m4015

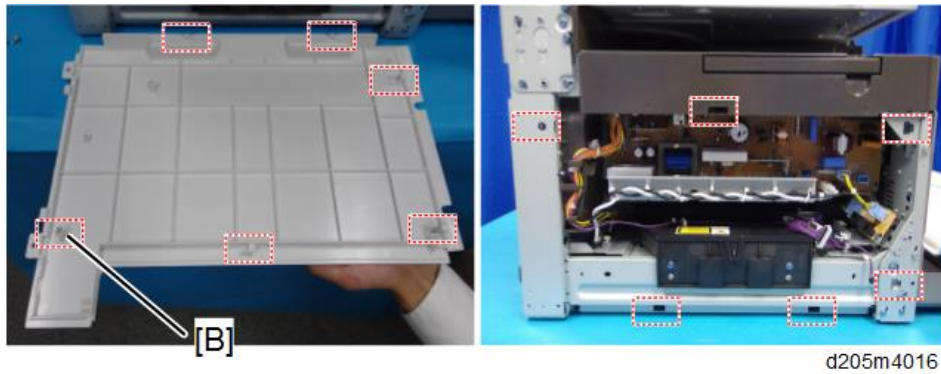

### 3.5.6 FRONT COVER

1. Pull the paper feed tray.
2. Do the following steps:
  1. Open the front cover.
  2. Push the hinge and detach the shaft.
  3. Remove the front cover [A].

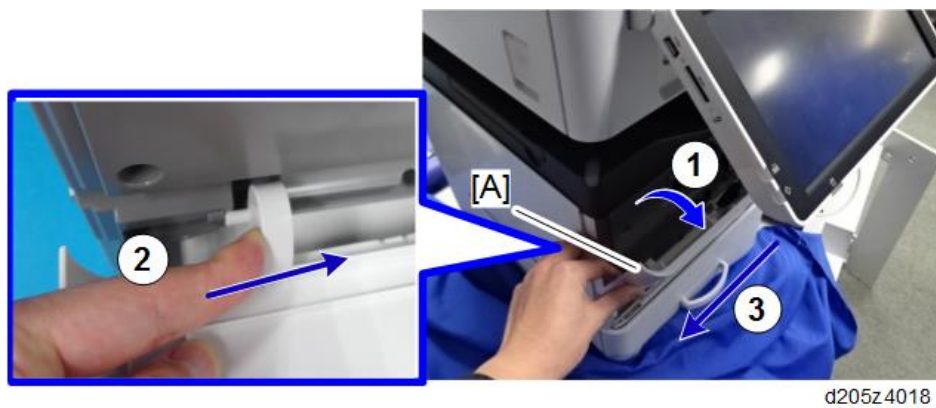

#### ⚠ Note

- To remove the front cover, disengage the pin at the left side as shown above.
- Before you disengaging the pin, do not lower the front cover more than 35 degrees, otherwise you might break the pin.

### 3.5.7 OPERATION PANEL REAR COVER

1. Front Upper Cover (page 3-7)
2. Operation Panel (page 3-35)
3. Operation Panel Rear Cover [A]

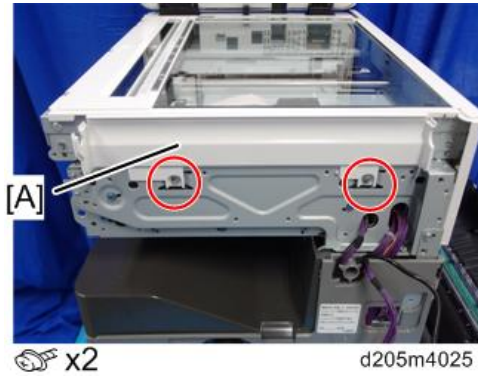

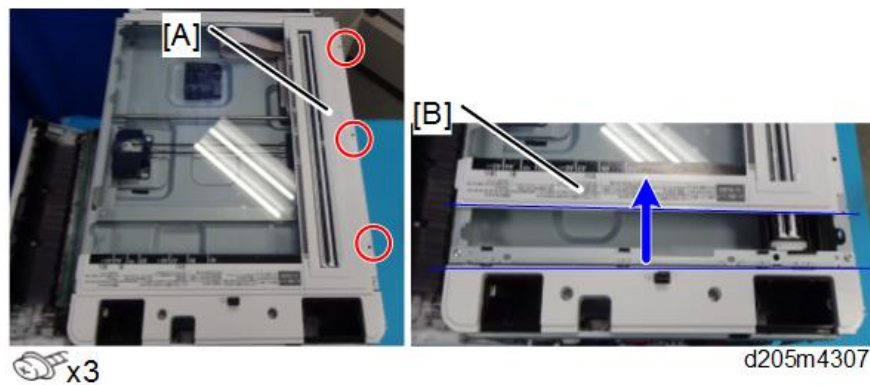

### 3.5.8 SCANNER REAR COVER

1. Rear Cover (page 3-5)
2. Left Upper Cover (page 3-8)
3. Right Upper Cover (page 3-6)
4. ARDF (page 3-14)
5. Remove the screws on the guide scale [A] and slide the scanner unit [B] to the front slightly.

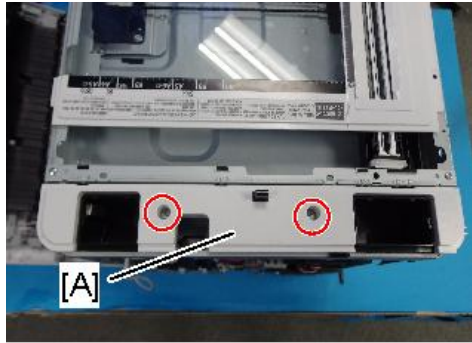

6. Scanner Rear Cover [A]



 x2

d205m4308

### 3.5.9 FRONT INNER COVER

1. Paper Feed Tray
2. Front Upper Cover (page 3-7)
3. PCDU (page 3-60)
4. Front Cover (page 3-10)
5. Release the harness [B] and remove the front inner cover [A].

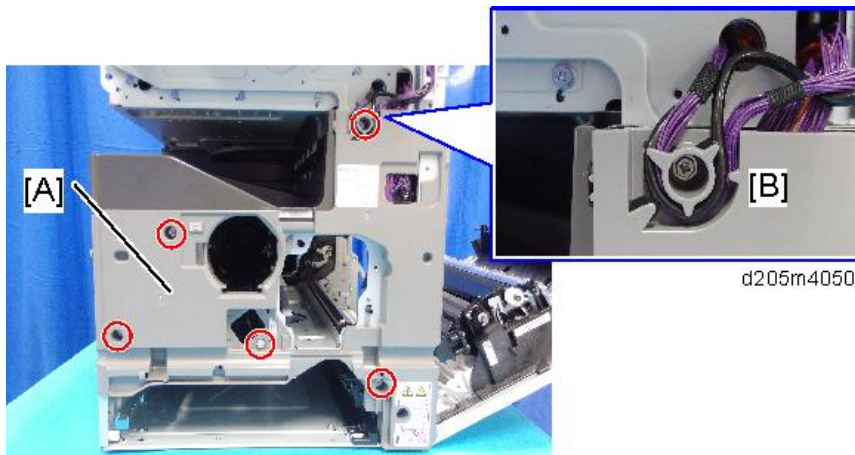

d205m4050

 x5

#### Note

- Slide down to remove the front inner cover [A].

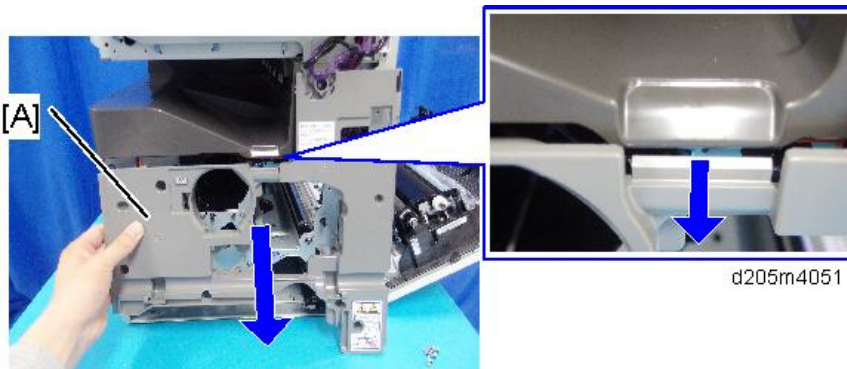

d205m4051



### 3.5.10 PAPER EXIT TRAY

1. Left Lower Cover (page 3-9)
2. Front Inner Cover (page 3-12)
3. Check the location of the tabs on the right side of the paper exit tray [A].

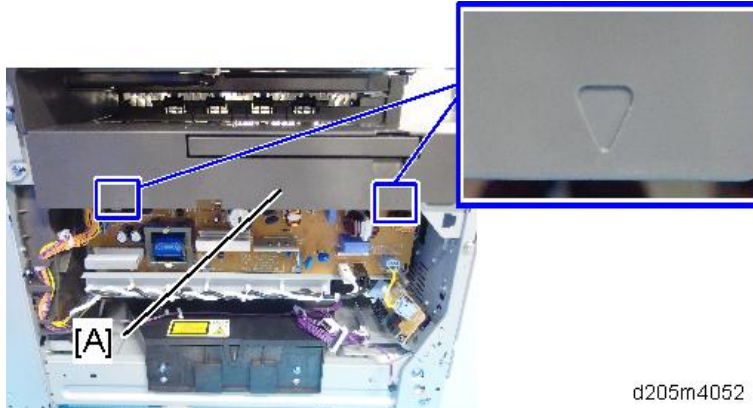

4. Release the tabs checked in step 3, at the rear of the cover.

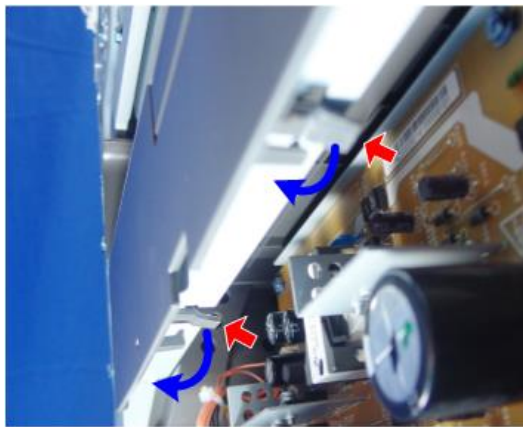

5. Remove the paper exit tray [A] by sliding it to the front.

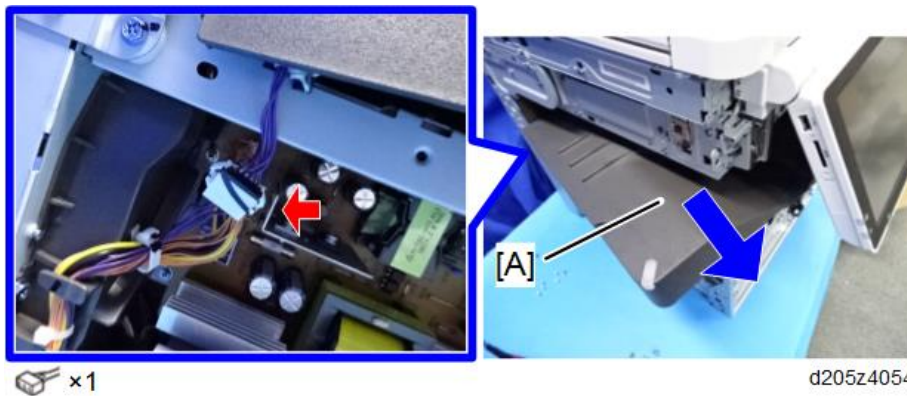

✖ x 1

## 3.6 ARDF

### 3.6.1 ARDF

1. Rear Cover (page 3-5)
2. Open the ARDF.
3. Harnesses and screws

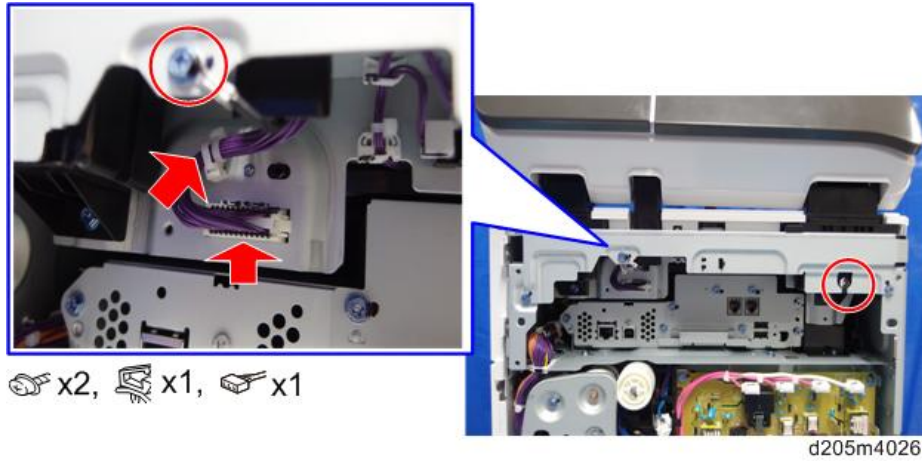

4. Lift up the ARDF [A] as much as possible. Then pull towards the rear to remove the ARDF from the machine.

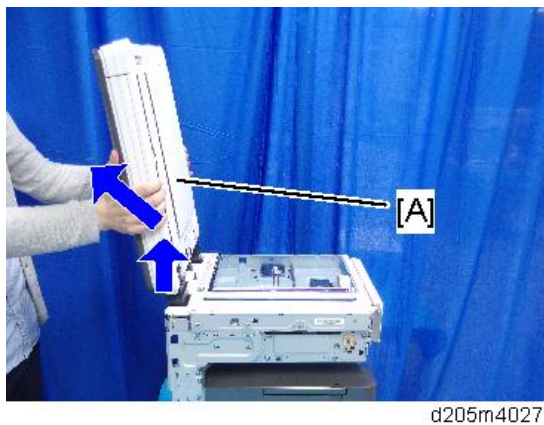

***After installing a New ARDF***

1. Open the ARDF.
2. Line up the platen sheet [A] on the rear left corner [B] of the exposure glass.
3. Close the ARDF to set the hook and loop fasteners [C: 4 points] on the platen sheet.

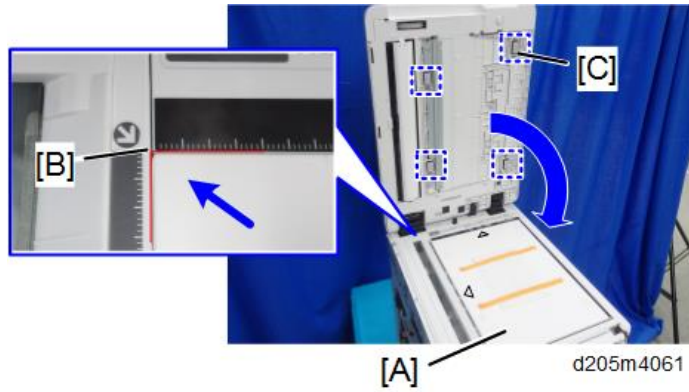

4. Open the ARDF and attach the sheet tightly.



### 3.6.2 ARDF EXTERIOR

#### *ARDF Front Cover*

1. Open the ARDF feed cover [A].



d205k4001

2. Remove the screw from the ARDF front cover [A].

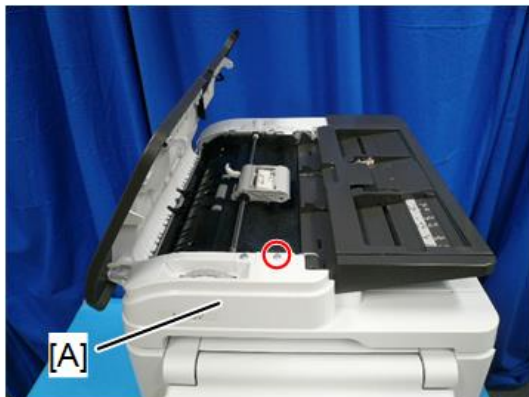

 x1

d205k4062

3. Open the copy holder [A] and then release the lock.

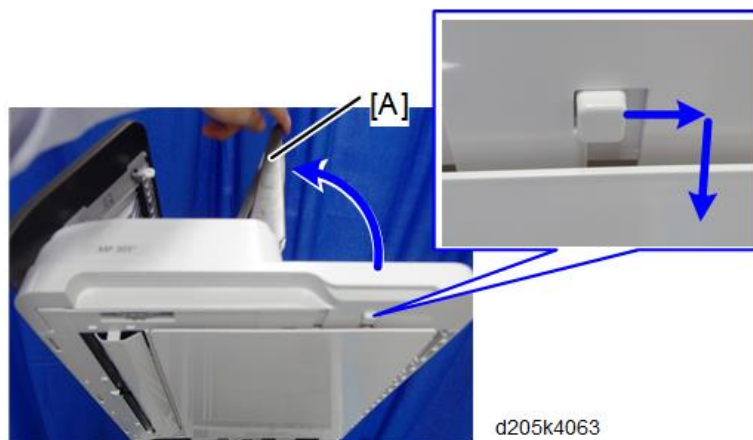

d205k4063

4. ARDF front cover [A]

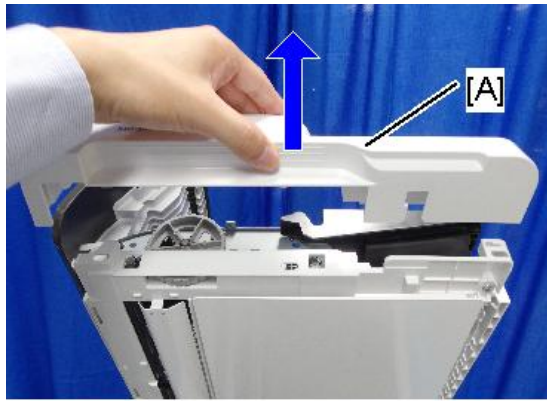

d205m4064

### ARDF Rear Cover

1. ARDF front cover (page 3-16)
2. Remove the screw from the ARDF rear cover [A].

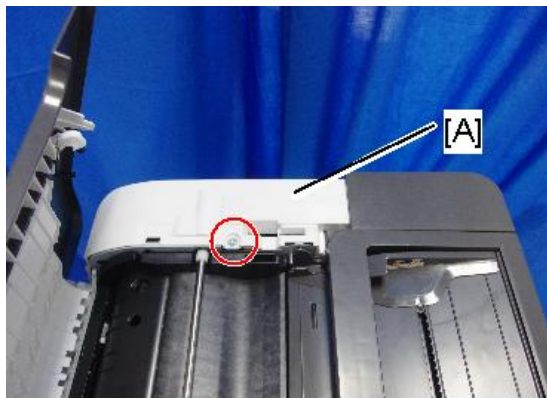
 x1

d205m4065

3. Release the tabs (3 points).

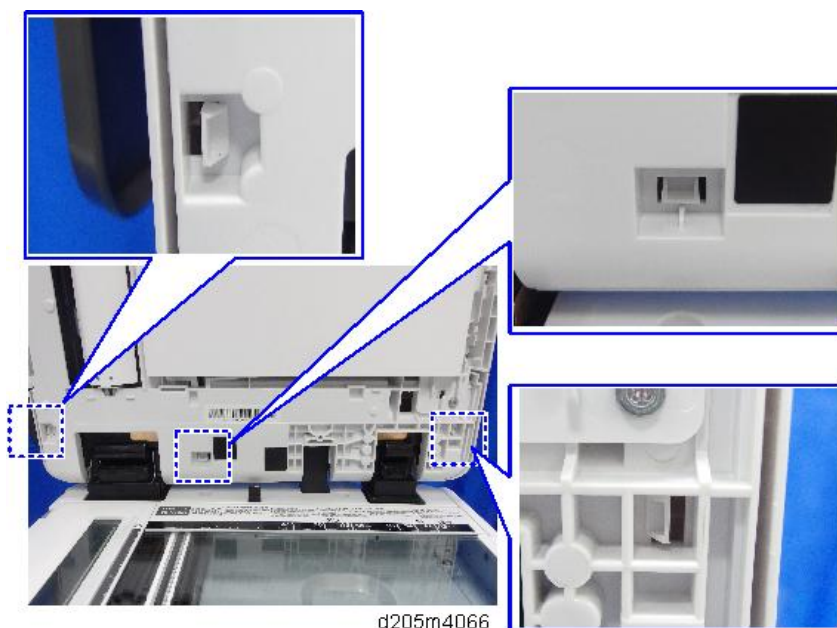

d205m4066

4. Open the copy holder [B] and the ARDF feed cover [C]. And then remove the ARDF rear

ARDF

cover [A].

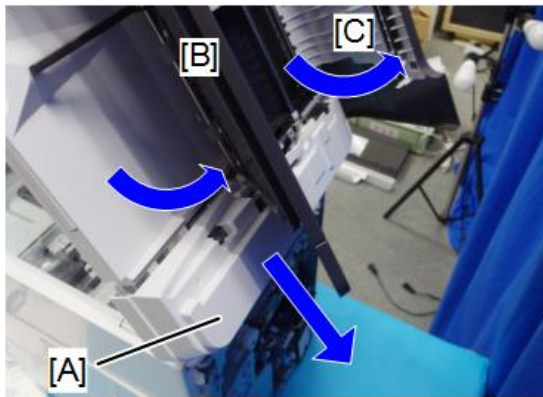

d205m4067

### ARDF Feed Cover

1. ARDF Front Cover (page 3-16)
2. ARDF Feed Cover [A]

Rear

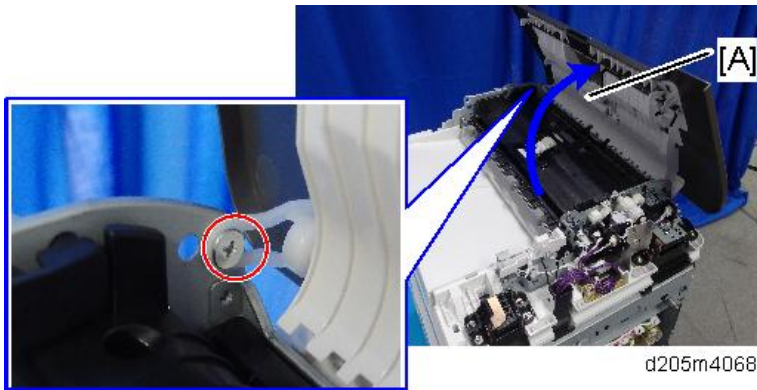

d205m4068

 x1

Front

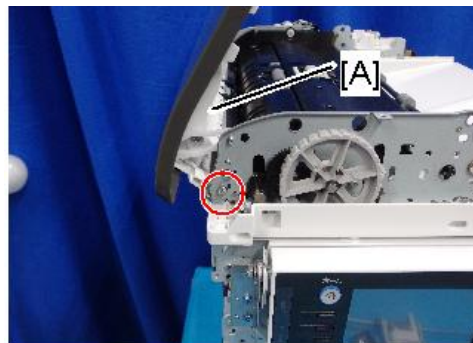

 x1

d205m4069

### Copy Holder

1. ARDF Rear Cover (page 3-17)
2. Clip ring

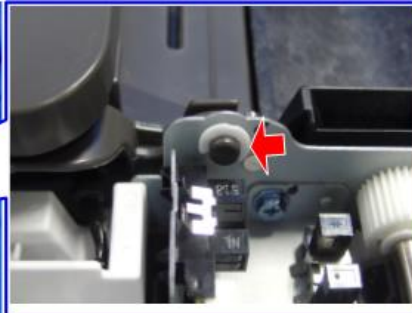
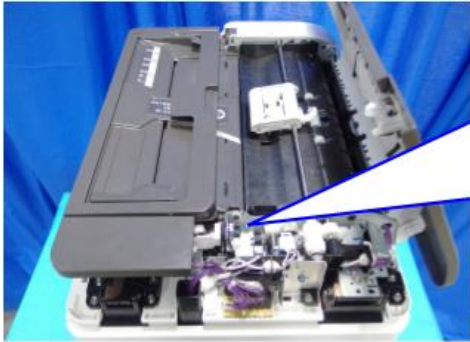



d205m4075

 x1

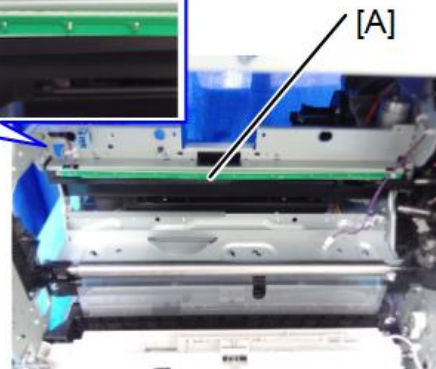
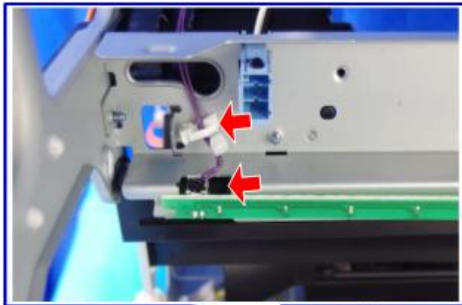
3. Remove the Copy Holder [A] and release the harnesses.





[A]

 x1,  x1

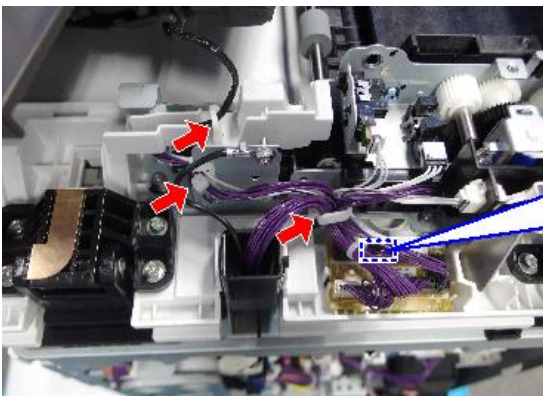
d205z4324



 x1,  x3

d205m4076



### 3.6.3 ARDF FEED UNIT

1. Open the ARDF feed cover.
2. ARDF Feed Unit [A]

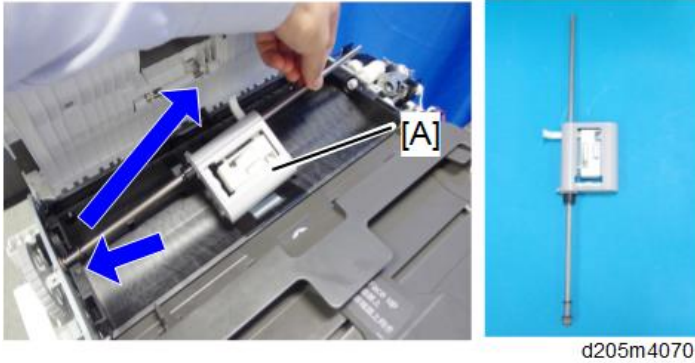

### 3.6.4 ARDF PICKUP ROLLER

1. ARDF Feed Unit (page 3-20)
2. Release the tab [A]

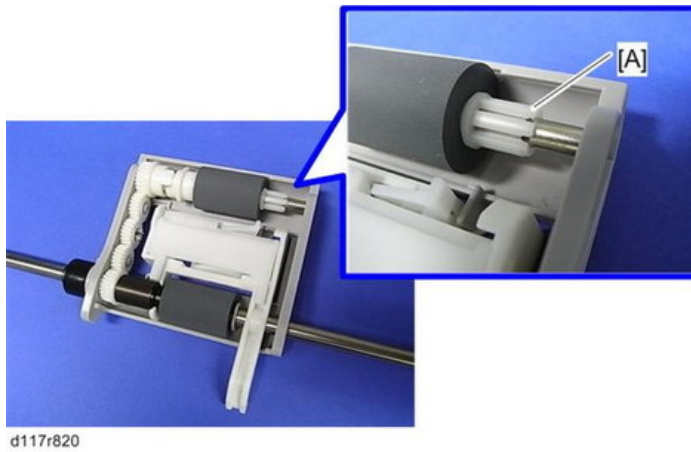

3. Slide the shaft [A] to remove the ARDF pickup roller [B].

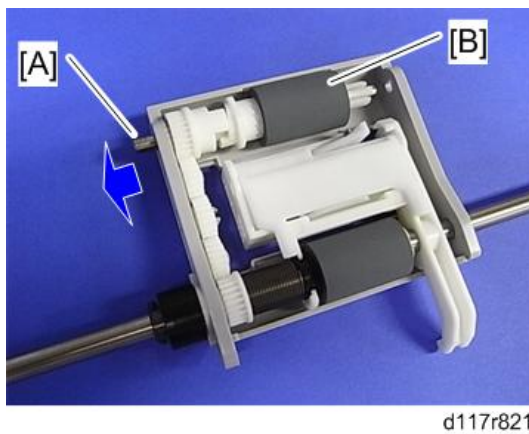

### 3.6.5 ARDF FEED ROLLER

1. ARDF Feed Unit (page 3-20)
2. Clip [A]

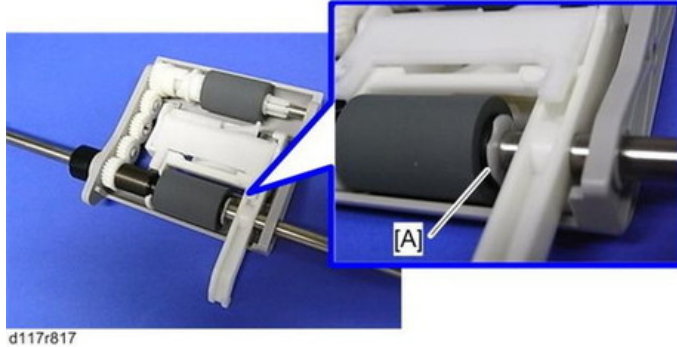

3. Slide the shaft [A] and pull the pin [B].

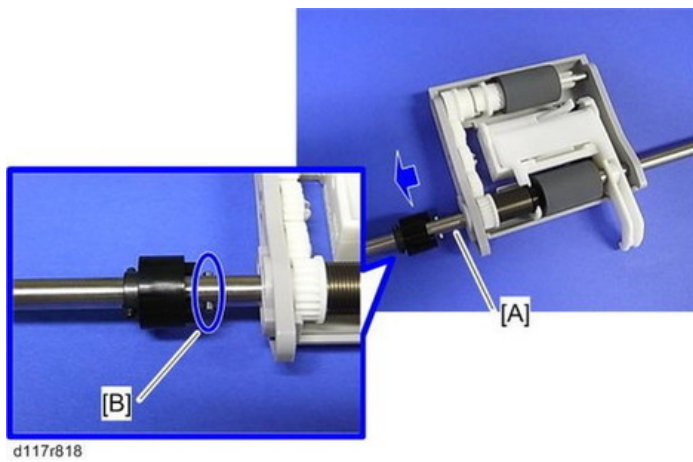

4. Slide the shaft [A] to remove the ARDF feed roller [B].

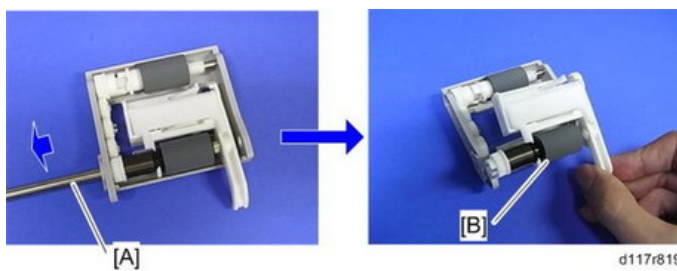

### 3.6.6 ARDF FRICTION PAD

1. ARDF Feed Unit (page 3-20)
2. Push the lock lever [A] and remove the friction pad [B].

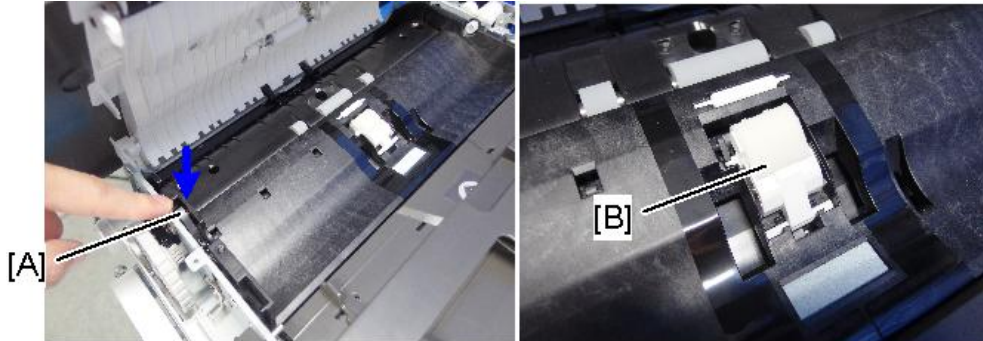

d205m4071

3. Separate the sheet, bracket, and friction pad [A].

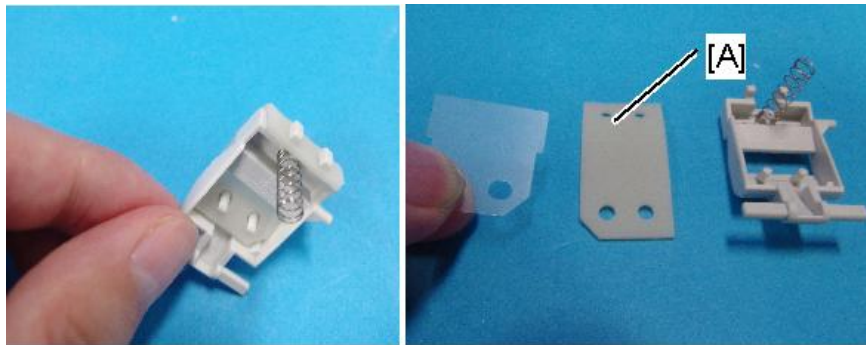



d205m4072

### 3.6.7 DFRB (DF RELAY BOARD)

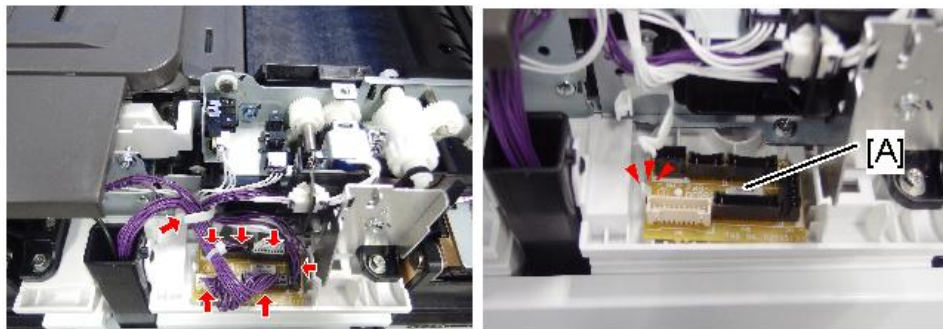
1. ARDF Rear Cover (page 3-17)
2. DFRB [A]



d205m4073

 x1,  x6

 **Note**

- There is a tab holding the DFRB [A].



### 3.6.8 ARDF FEED COVER SENSOR, ORIGINAL SET SENSOR

1. ARDF Rear Cover (page 3-17)
2. Remove the following:
  1. ARDF Feed Cover Sensor [A]
  2. Original Set Sensor [B]

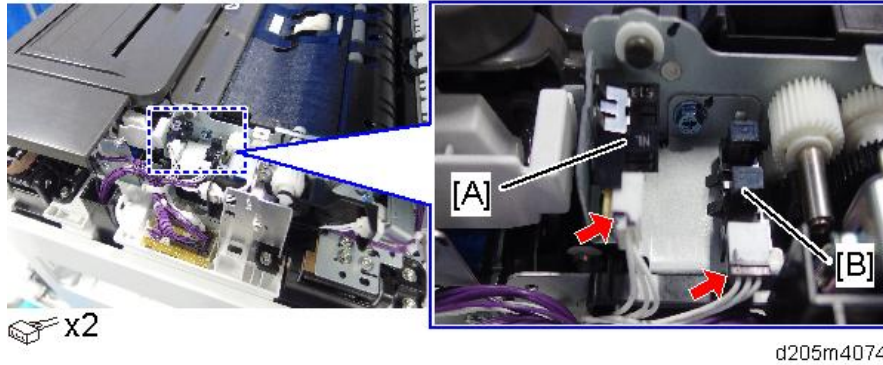

#### ↓ Note

- If it is difficult to remove the original set sensor [B], remove the bracket and release the tab.

### 3.6.9 ARDF ORIGINAL WIDTH SENSOR

1. ARDF Rear Cover (page 3-17)
2. Copy Holder (page 3-19)
3. Rear cover [A] of the copy holder.

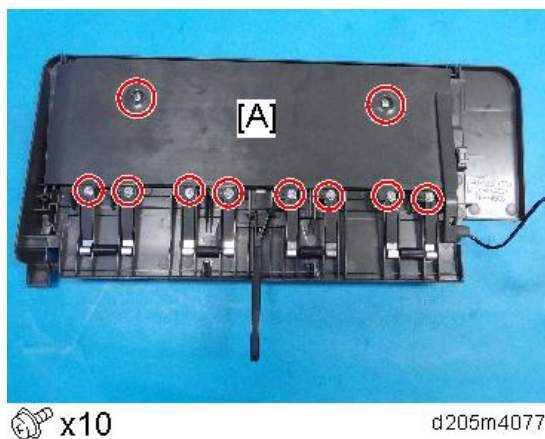

4. ARDF Original Width Sensor [A]

ARDF

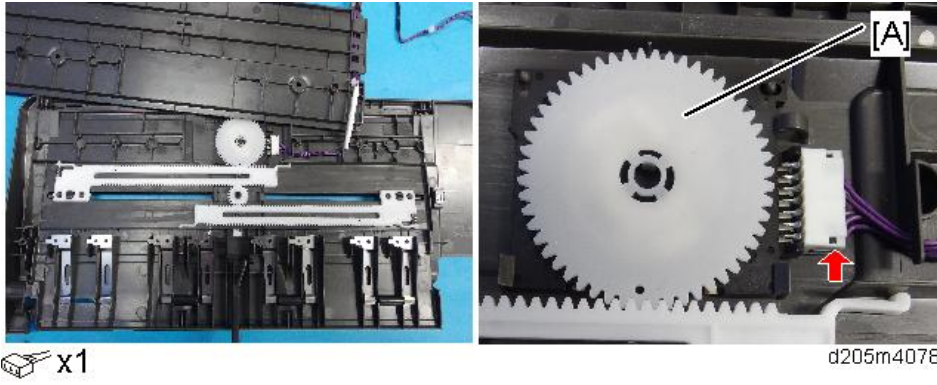

***Precaution for Installing the ARDF Original Width Sensor***

Open the ARDF original width guide to the maximum and install the ARDF original width sensor. The holes must align as shown below.

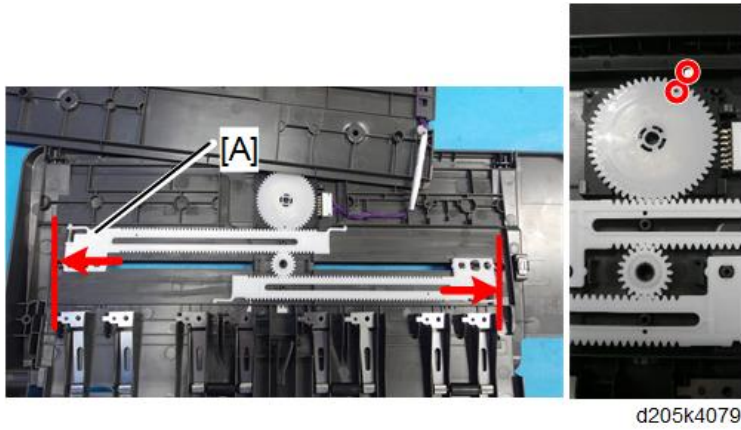

### 3.6.10 ARDF DRIVE MOTOR

#### ⚙️ Preparation

- When removing the ARDF drive motor, the ARDF must be removed. (page 3-14)

- ARDF front cover (page 3-16)
- ARDF rear cover (page 3-17)
- ARDF feed cover (page 3-18)
- Upper guide plate [A]

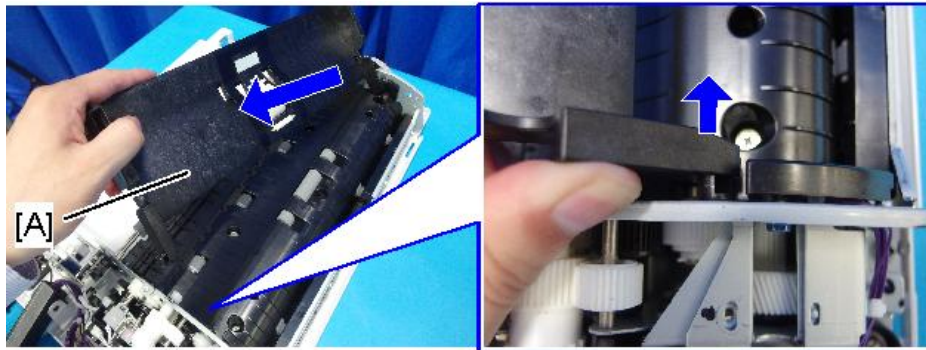

d205m4080

- Lower guide plate [A]

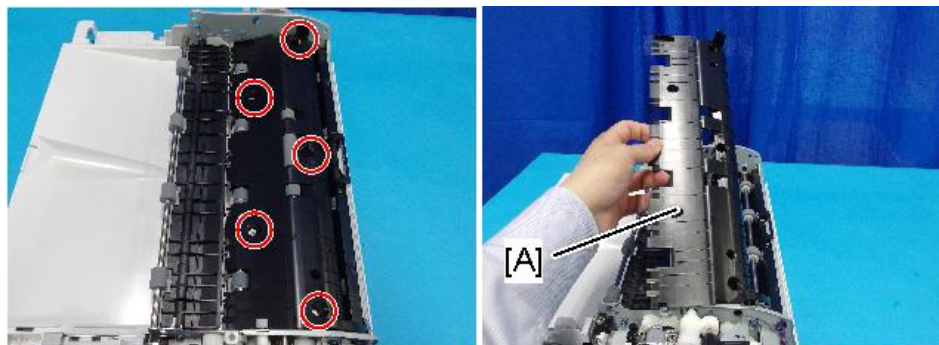

x5

d205m4081

- Bracket [A]

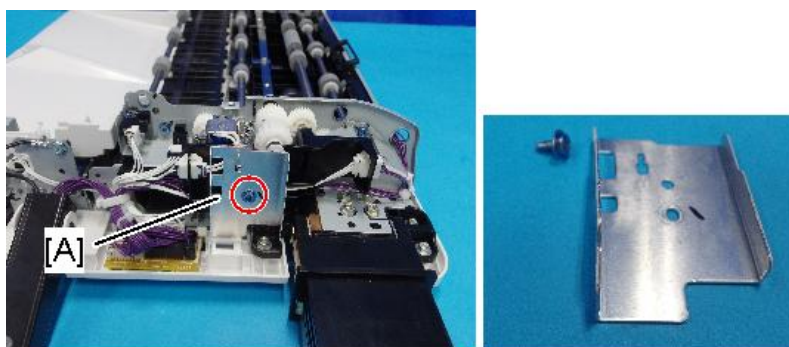

x1

d205m4082

- Harnesses of the holder



ARDF

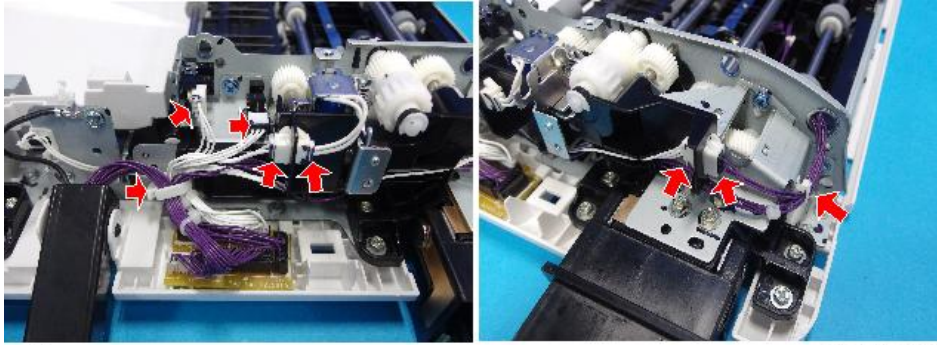

 x2,  x6

d205m4083

### 8. Harness Holder [A]

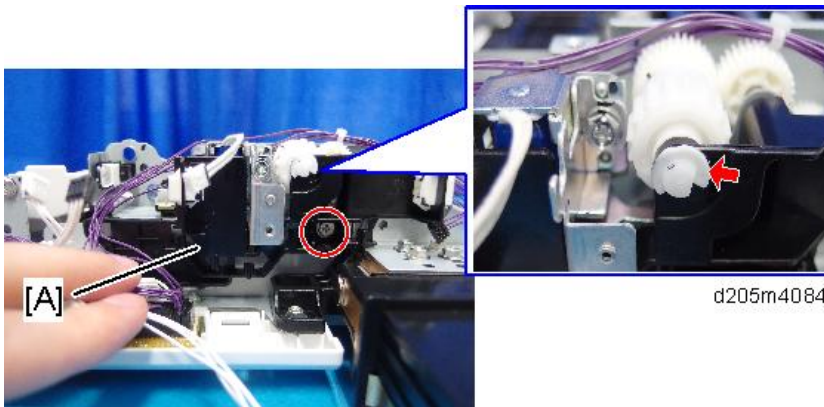

d205m4084

 x1,  x1

### 9. ARDF paper feed solenoid [A] and bracket [B]

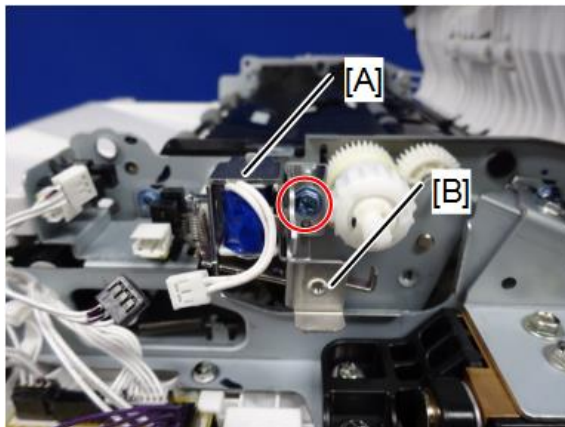

 x1

d205z4187

### 10. Bracket [A] and the hinge [B]

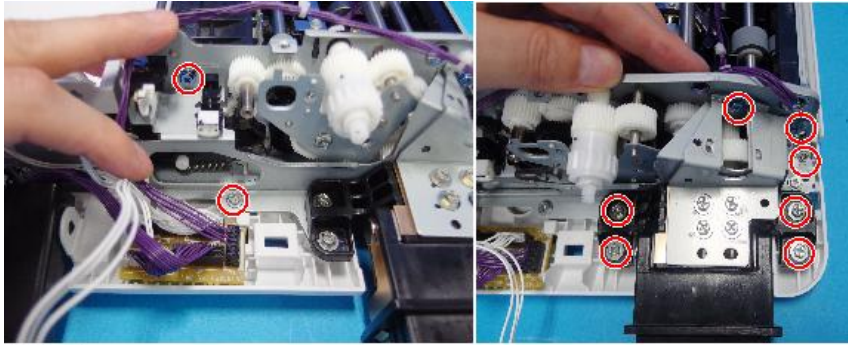

 x9

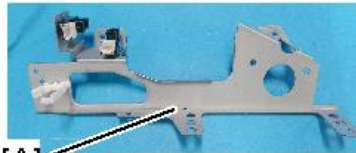

[A]

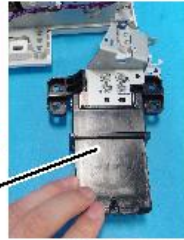

[B]

d205m4086

11. Bracket [A]

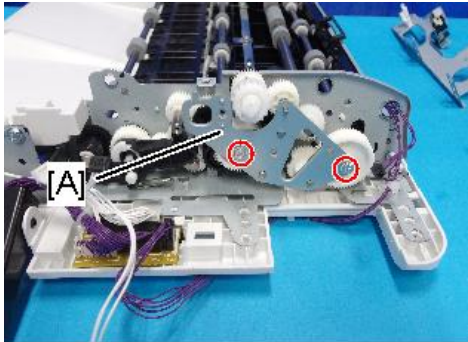

[A]

 x2

d205m4087

12. ARDF Drive Motor [A]

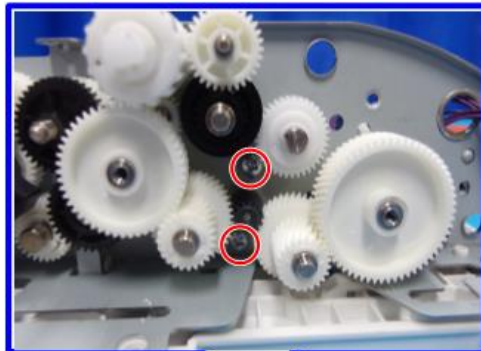

 x2

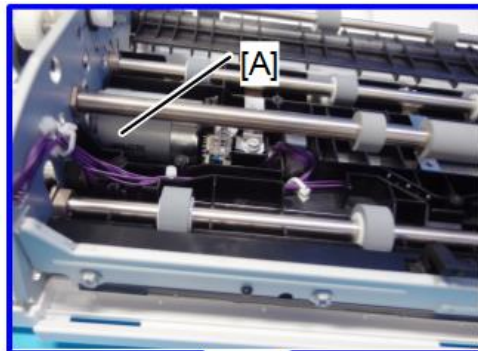

[A]

d205m4088

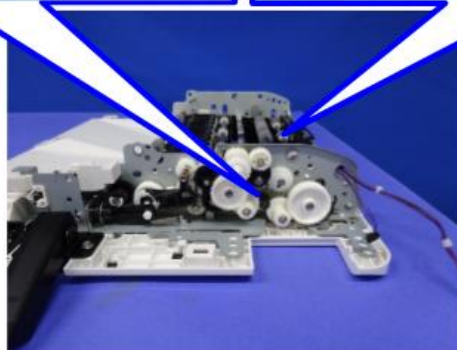

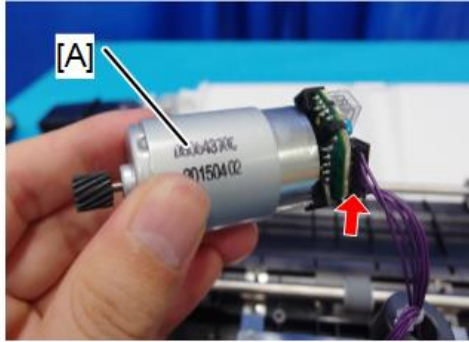

 x1

d205z4089

**★ Important**

- Do not touch the encoder [A].

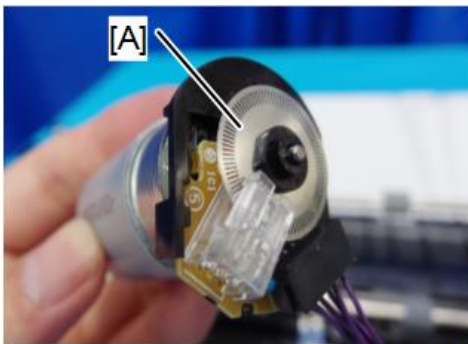

d205m4089

### ***Precautions for Installing the Lower Guide Plate***

When installing the lower guide plate, be careful of the following points:

- Tighten the screws in the order shown below.
- Do not use non-recommended equipment such as an electric screwdriver.
- Do not fasten the screws too tightly. Otherwise, the ARDF lower guide plate will be installed at an angle, and this will cause skew.





### 3.6.11 ARDF PAPER FEED SOLENOID

#### Preparation

- When removing the ARDF paper feed solenoid, the ARDF must be removed. (page 3-14)

- ARDF rear cover (page 3-17)
- ARDF feed cover (page 3-18)
- Bracket [A]

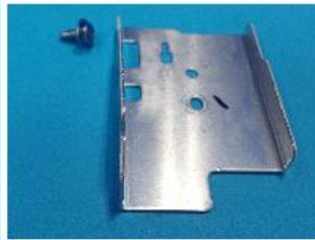
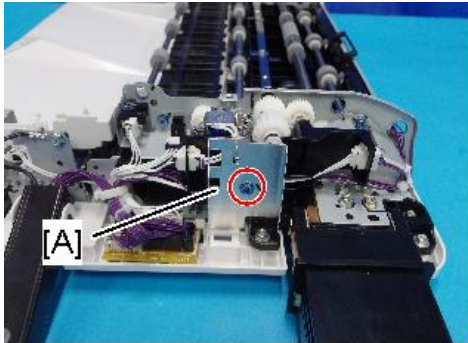

 x1

d205m4082

- ARDF paper feed solenoid [A] and bracket [B]

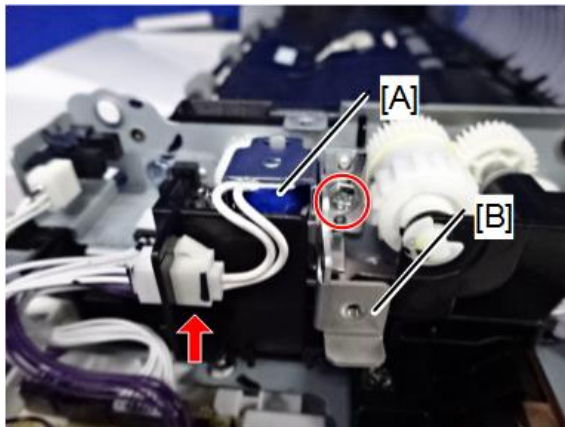

 x1  x1

d205z4182

### 3.6.12 ARDF REVERSE SOLENOID

#### Preparation

- When removing the ARDF reverse solenoid, the ARDF must be removed. (page 3-14)

- ARDF front cover (page 3-16)
- ARDF rear cover (page 3-17)
- ARDF feed cover (page 3-18)
- Copy holder (page 3-19)
- Bracket [A]

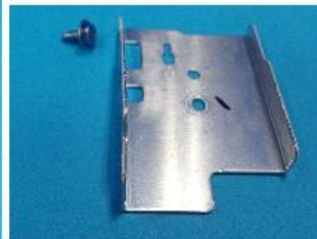
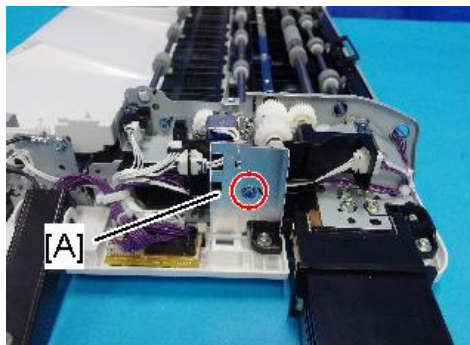

 x1

d205m4082

- Release the harness.

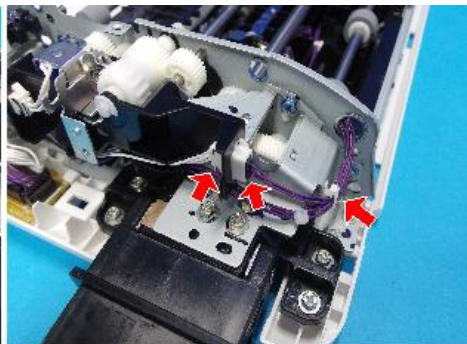
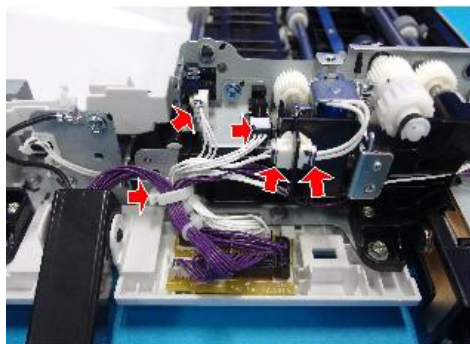

 x2,  x6

d205m4083

- Harness holder [A]

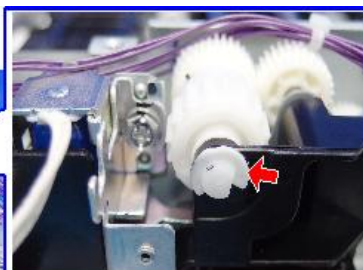
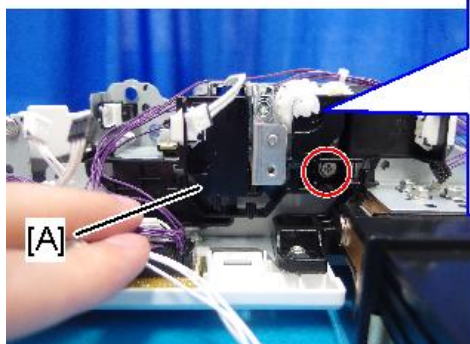

d205m4084

 x1,  x1

8. Paper feed solenoid [A] and bracket [B]

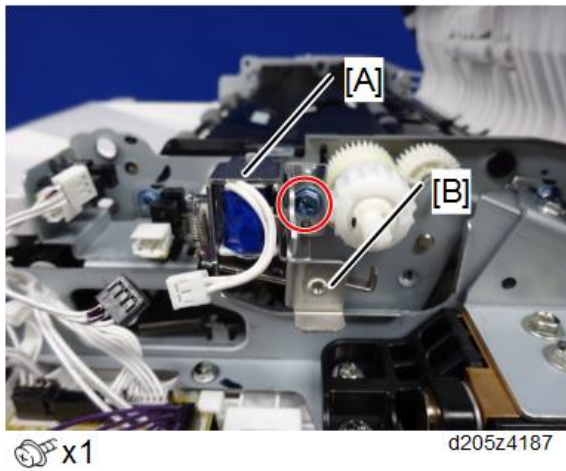

9. Bracket [A] and hinge [B]

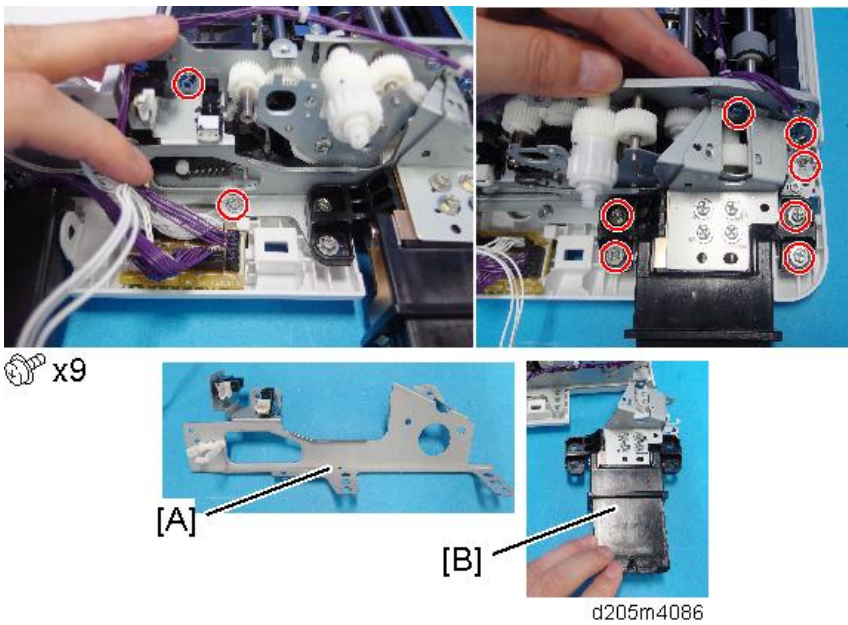

10. Harness holder [A][B]

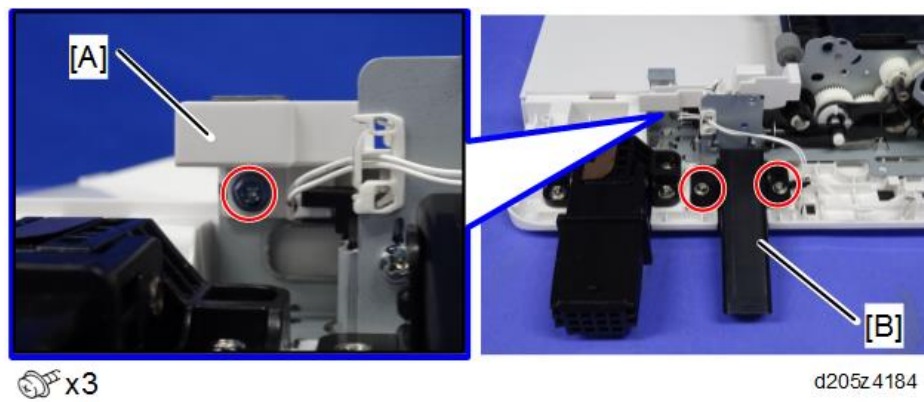

11. Release the linkage [B] and remove the ARDF reverse solenoid [A].

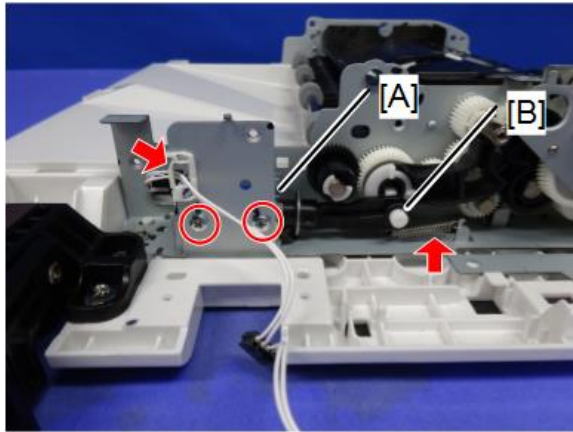

⚙️ x2, 🔧 x1, 🌀 x1 d205z4185

12. ARDF reverse solenoid [A]

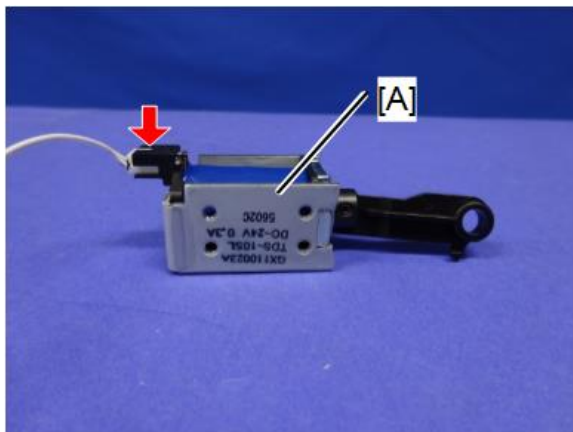

🔑 x1, d205z4186

Replacement and Adjustment



### 3.6.13 ARDF SCANNING GUIDE PLATE, ARDF REGISTRATION SENSOR

#### 1. ARDF Scanning Guide Plate [A]



d205m4091

#### 2. ARDF registration sensor [A]

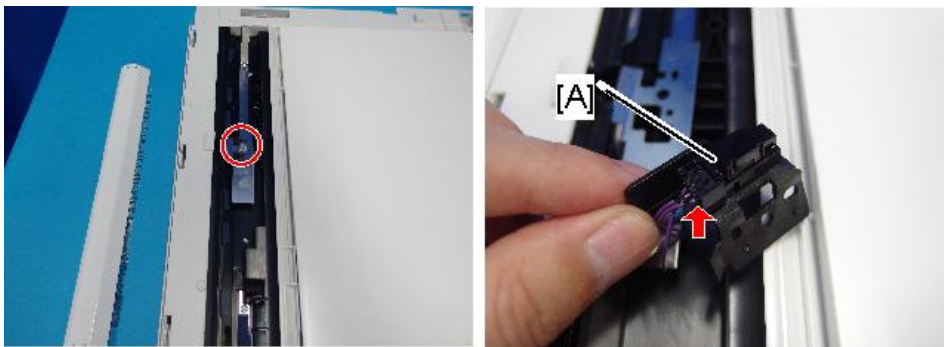

 x1,  x1

d205m4092

#### ***Precaution when Installing the ARDF Scanning Guide Plate***

The sheets [A] must not be under the ARDF scanning guide plate.

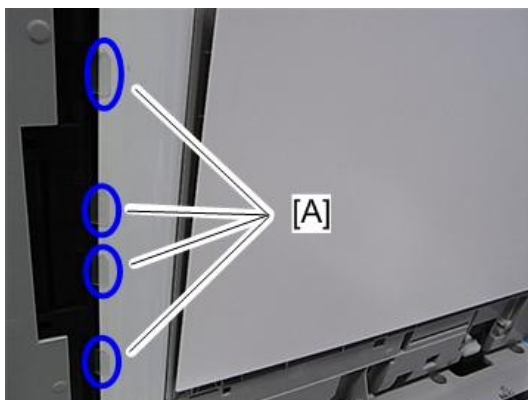

d117r839

## 3.7 OPERATION PANEL

This section includes only the replacement procedure which is unique for the MP 305+ series. The replacement procedures for the other parts are included in the FSM for the Smart Operation Panel, because these parts are also used with other models.

### 3.7.1 OPERATION PANEL

1. Place the service mat on top of the ARDF.
2. Front upper cover (page 3-7)
3. Brackets [A] of the operation panel unit

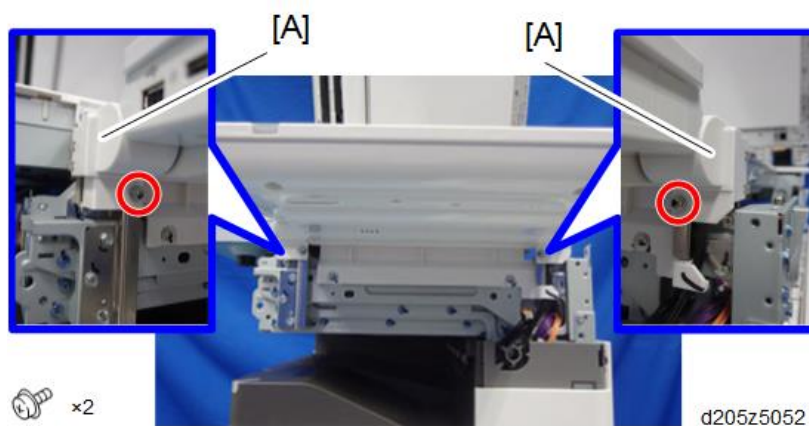

4. Hinges of the operation panel unit

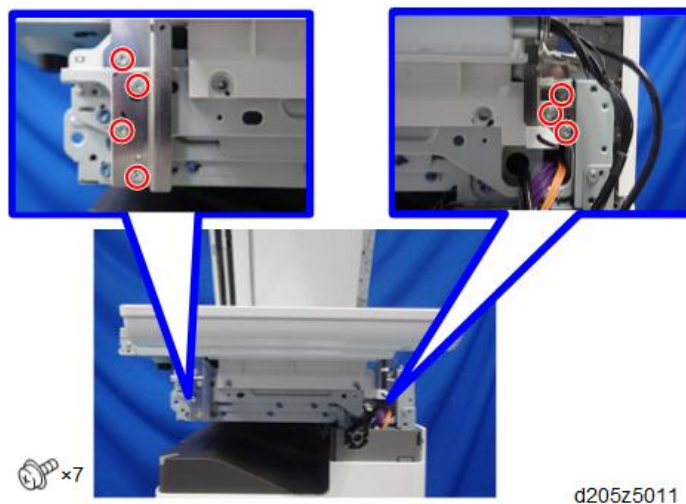

5. Remove the operation panel unit and put it on the service mat.

## Operation Panel

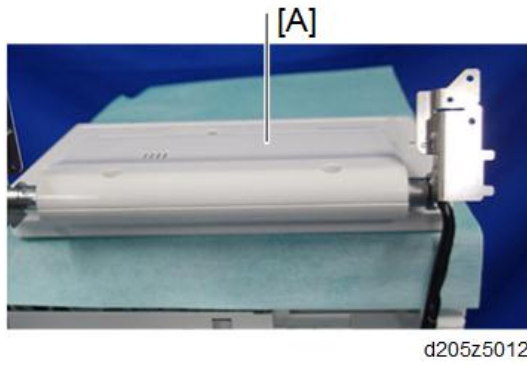

### 6. Rear cover [A] of the operation panel unit

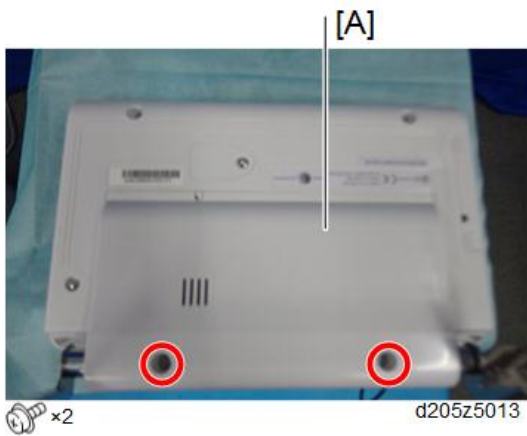

### 7. Disconnect the harness and the USB cable.

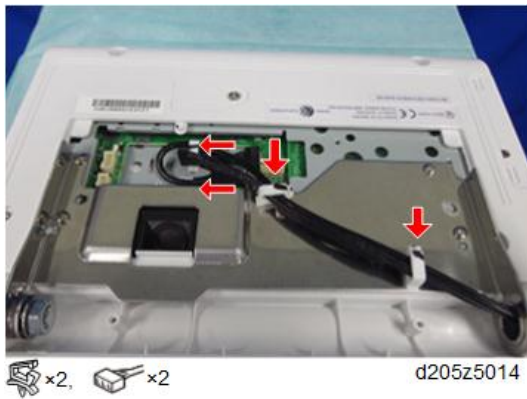

## 3.7.2 INTERNAL PARTS

Refer to the FSM for the Smart Operation Panel.



## 3.8 SCANNER

### 3.8.1 SCANNER UNIT

1. Right upper cover (page 3-6)
2. Left upper cover (page 3-8)
3. Remove the screws of the scanner unit at the right and left.

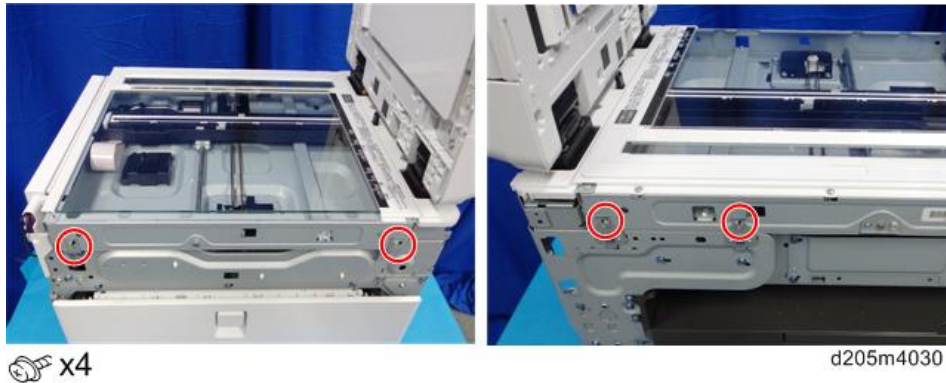

4. Slide the scanner unit about 10 cm to the right.
5. Release the FFC on the BiCU.

Unlock the connector and release it.

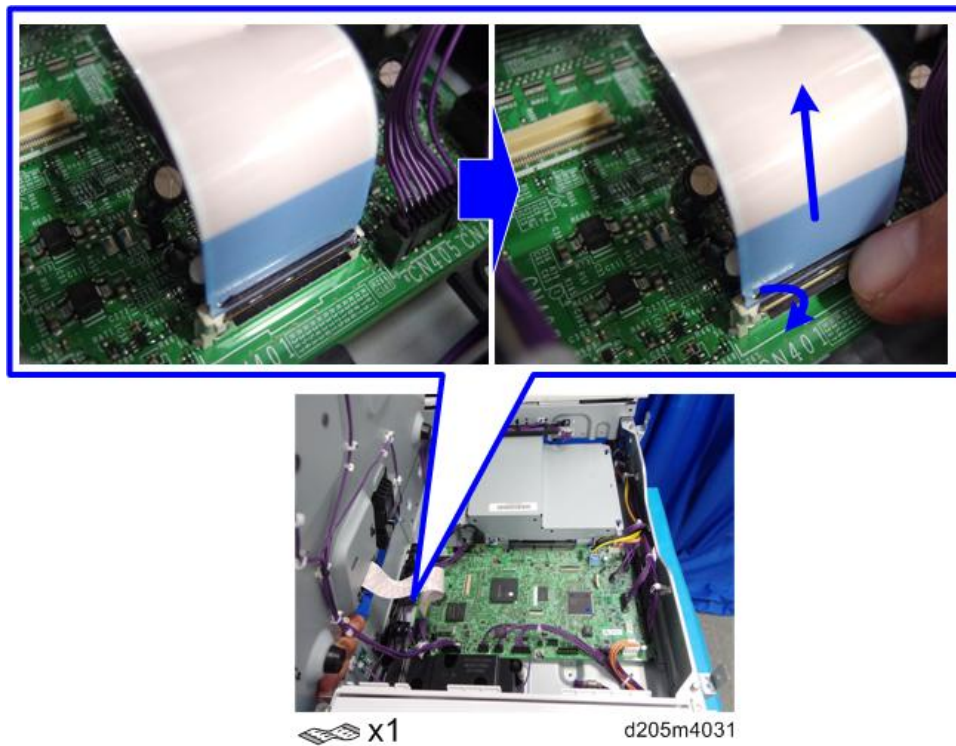

6. Release all the other harnesses and remove the scanner unit [A].

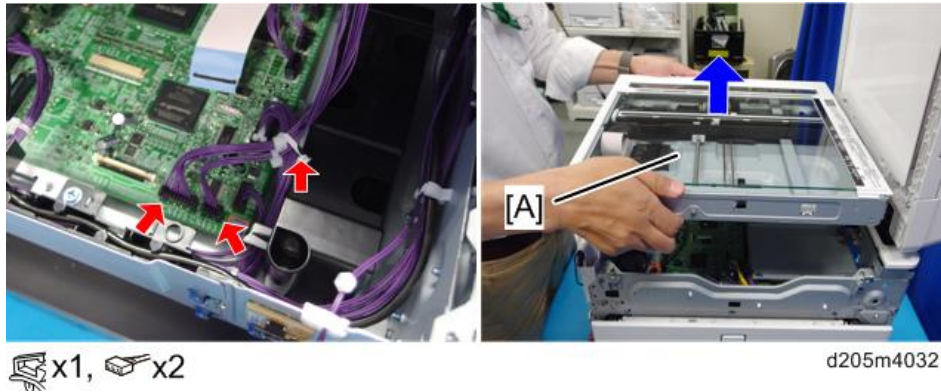

### 3.8.2 SCANNER FRONT COVER

1. Scanner unit (page 3-37)
2. Scanner front cover [A]

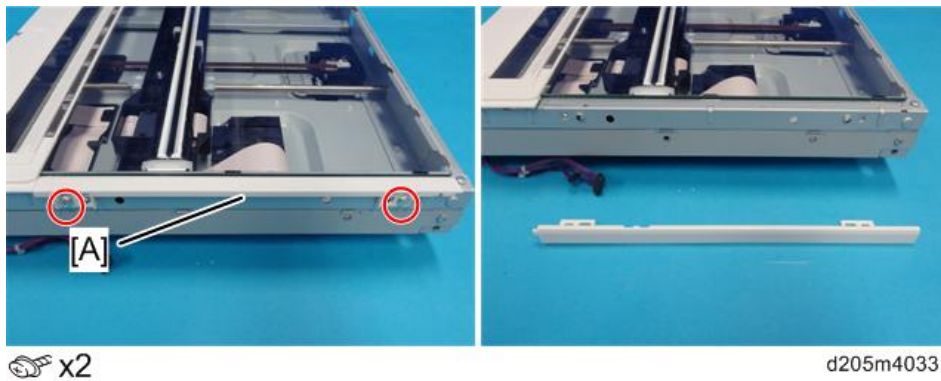

### 3.8.3 EXPOSURE GLASS, ARDF EXPOSURE GLASS, LEFT SCALE AND REAR SCALE

**Note**

- All these parts are attached with hook and loop fasteners.

**Important**

- For replacing the ARDF exposure glass, order a [seal:preventfence] (D2051770) separately.

1. Scanner unit (page 3-37)
2. Screws of the left scale [A]

**Note**

- To remove the exposure glass, hold the glass by its front left and rear right enclosed by the red-dotted line [B]. Do not hold it by the scale.

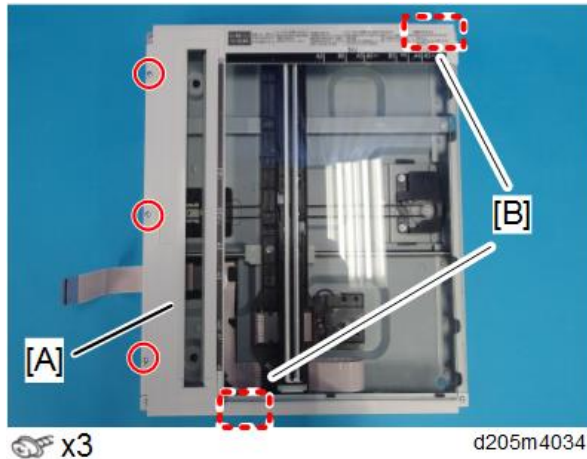

### Outline

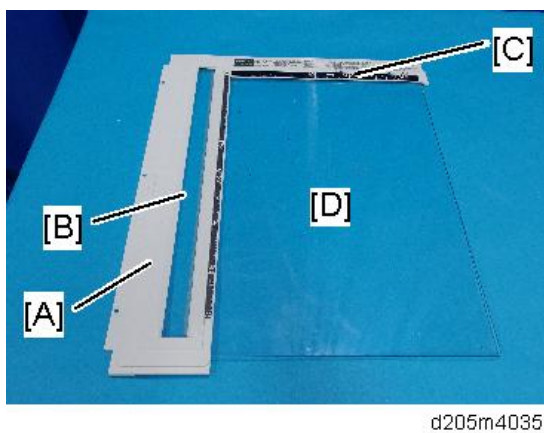

[A]: Left Scale

[B]: ARDF Exposure Glass

[C]: Rear Scale

[D]: Exposure Glass

3. For replacing the ARDF exposure glass, remove the Seal:prevention [A].

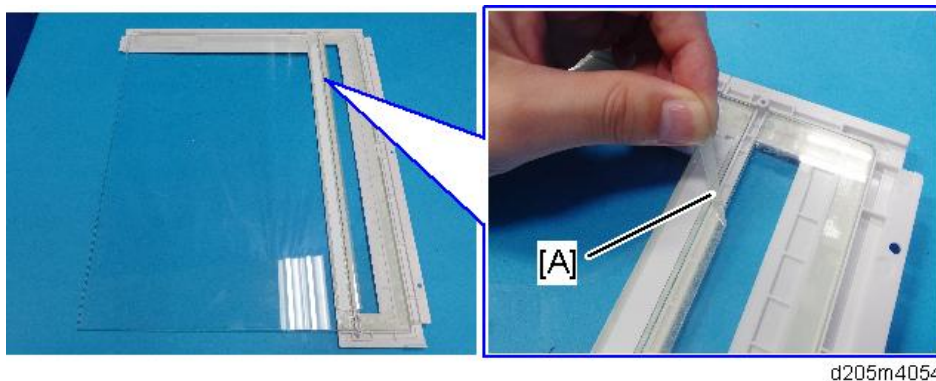

### **Precaution for Installing These Parts**

The ARDF exposure glass and the exposure glass have markings that show the correct orientation.

[A]: Red point on the exposure glass

[B]: Blue point on the ARDF exposure glass

# Scanner

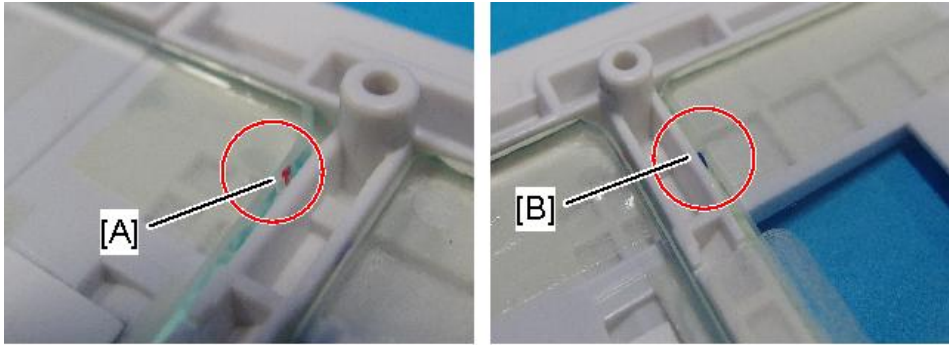

d205m4055

Set the 2 points [A] and [B] to face each other as shown below. After that, attach new sticky tape.

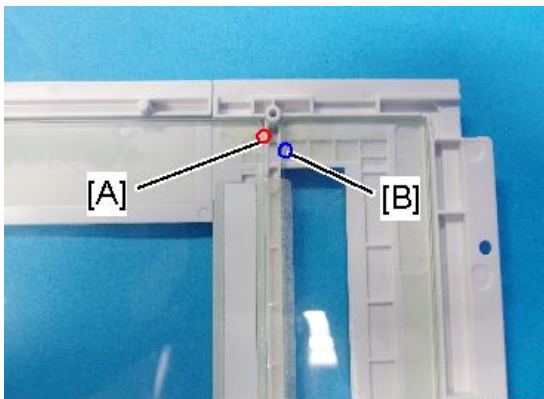

d205m4056

Stick the tape at the following location.

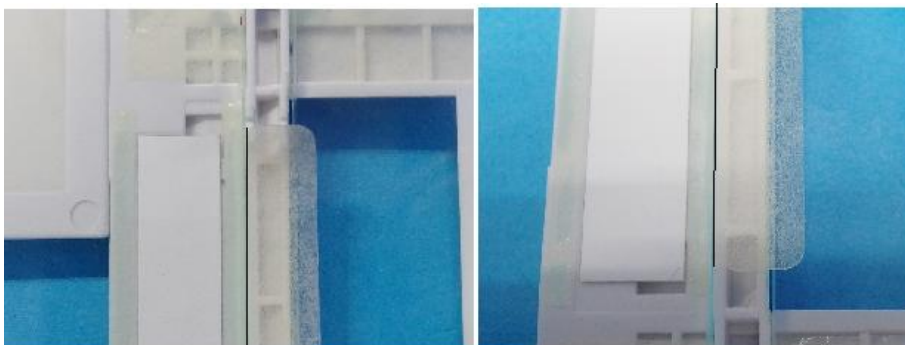

d205m4057



### 3.8.4 APS SENSOR 1, 2

#### ⏴ Note

- North America: 1 APS sensor
- Others: 2 APS sensors

1. Exposure glass (page 3-38)
2. APS sensor(s) [A]

#### *North America*

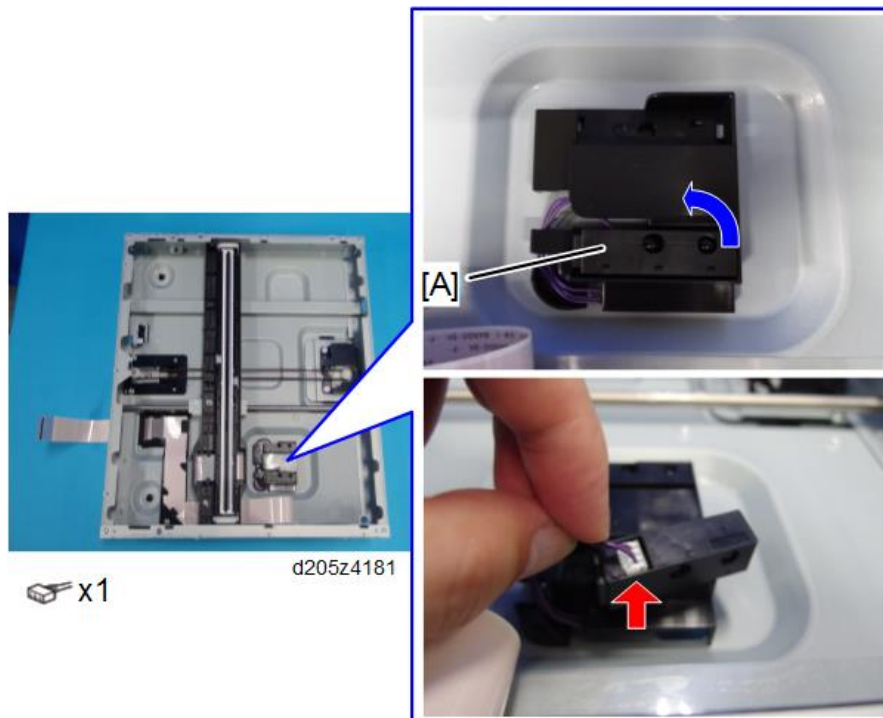

Scanner

**Others**

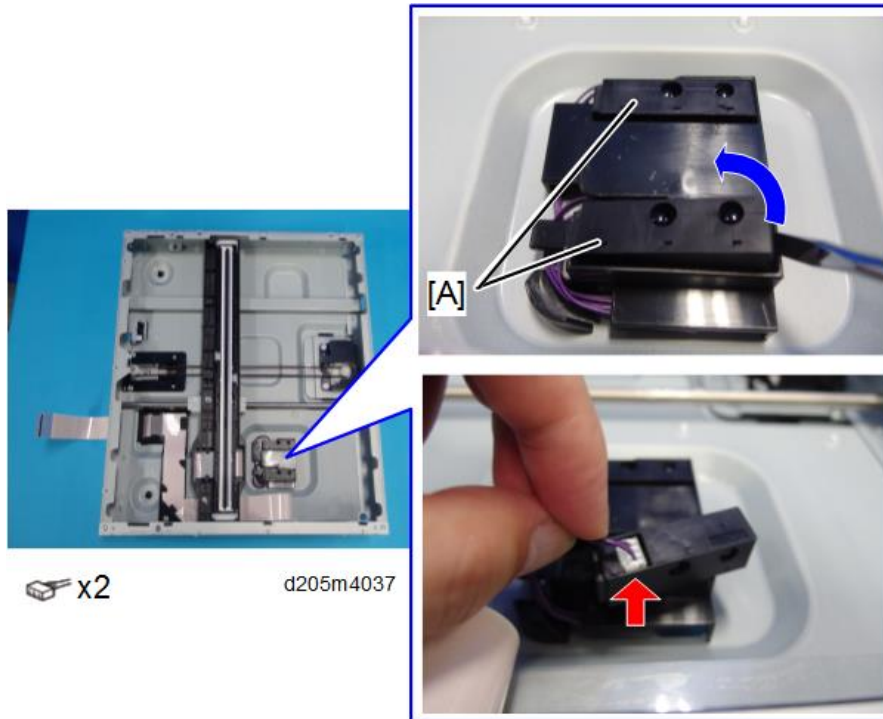

**3.8.5 SCANNER HP SENSOR**

1. Exposure glass (page 3-38)
2. Scanner HP sensor [A]

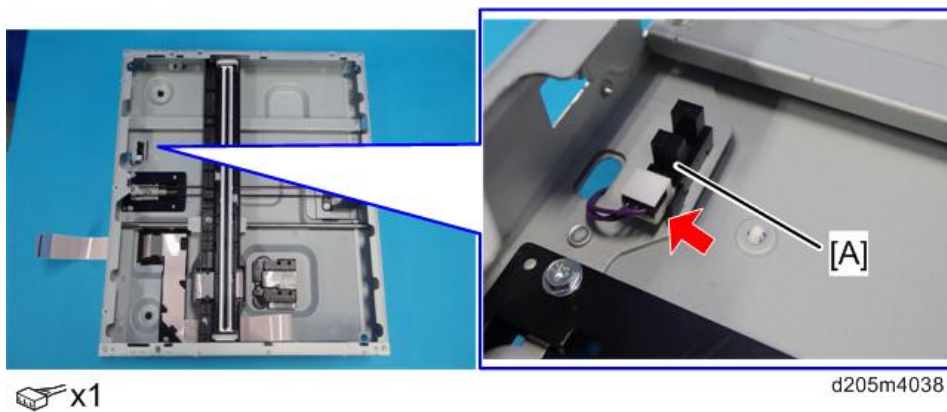

### 3.8.6 TIMING BELT

1. Exposure glass (page 3-38)
2. Scanner motor [A]

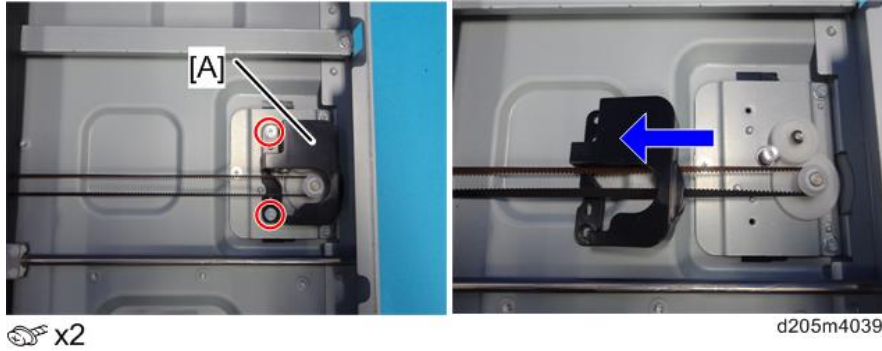

3. Release the timing belt [A] from the gear.

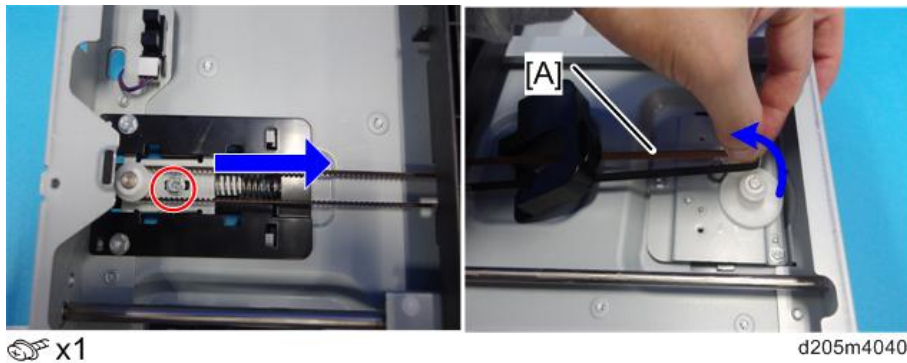

4. Move the CIS carriage [A] to the cut out in the frame and remove it.

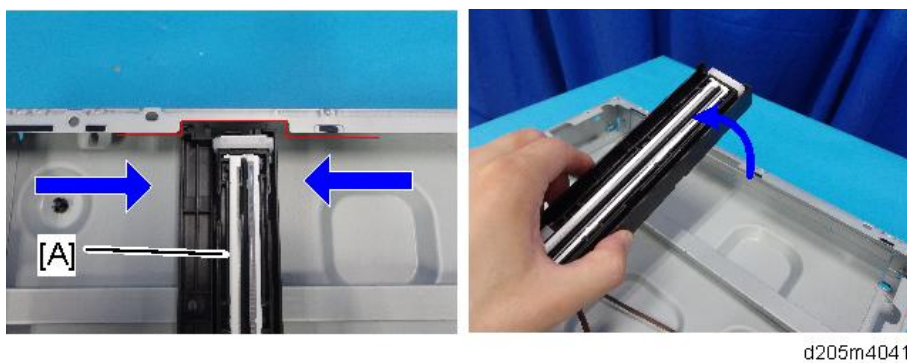

5. Timing belt [A]

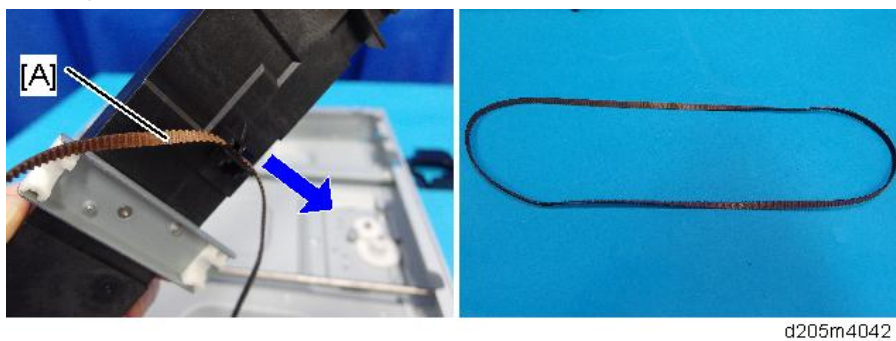

Replacement and Adjustment



### 3.8.7 SCANNER MOTOR

1. Exposure glass (page 3-38)
2. Scanner motor cover [A]

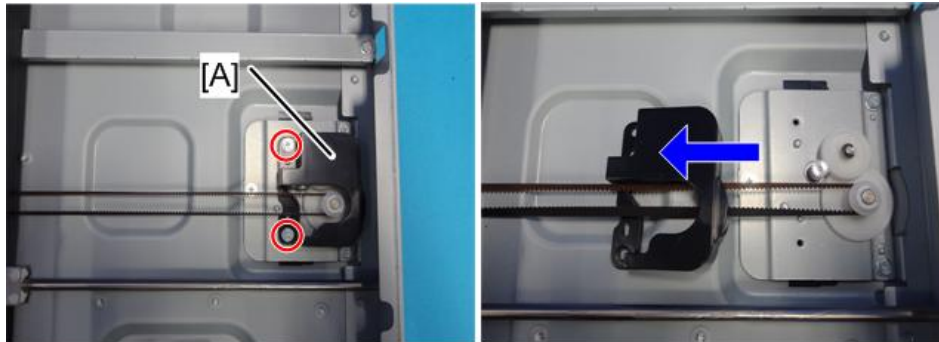



 x2

d205m4039

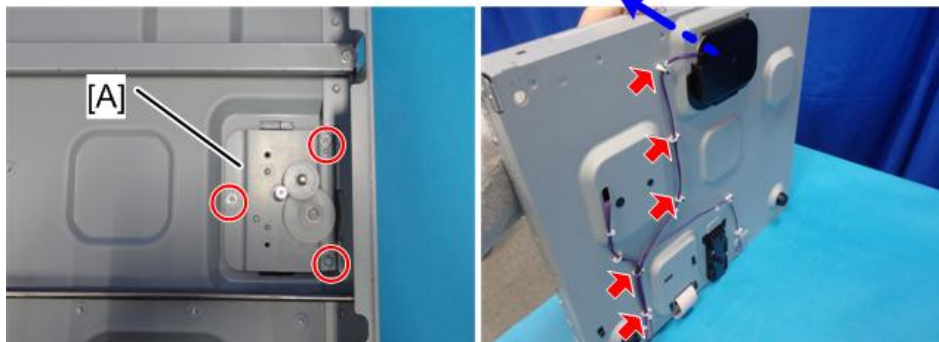
3. Motor bracket [A]



 x3,  x5

d205m4043

4. Scanner motor [A]

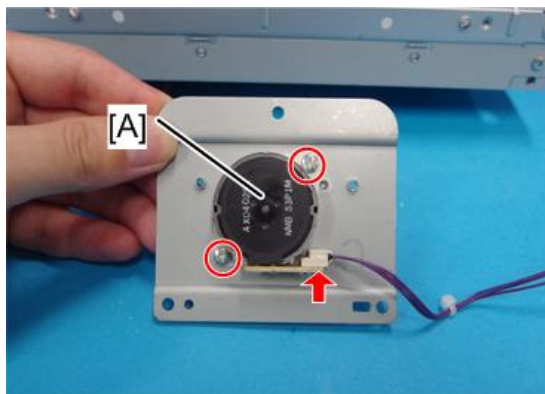

 x2

d205m4044

5. Apply grease at the following locations [A].

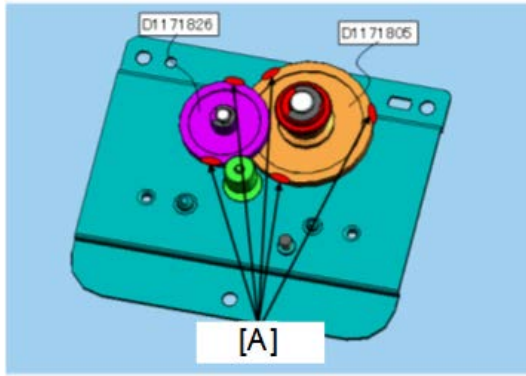

d205k4015

Minimum amount



Maximum amount



w\_d205k4082

Replacement  
and Adjustment

### 3.8.8 CIS

After changing the CIS

SP	Detail
SP4-803-001	HP Position Adjust

1. **Unlock the front lock and turn over the CIS [A].**

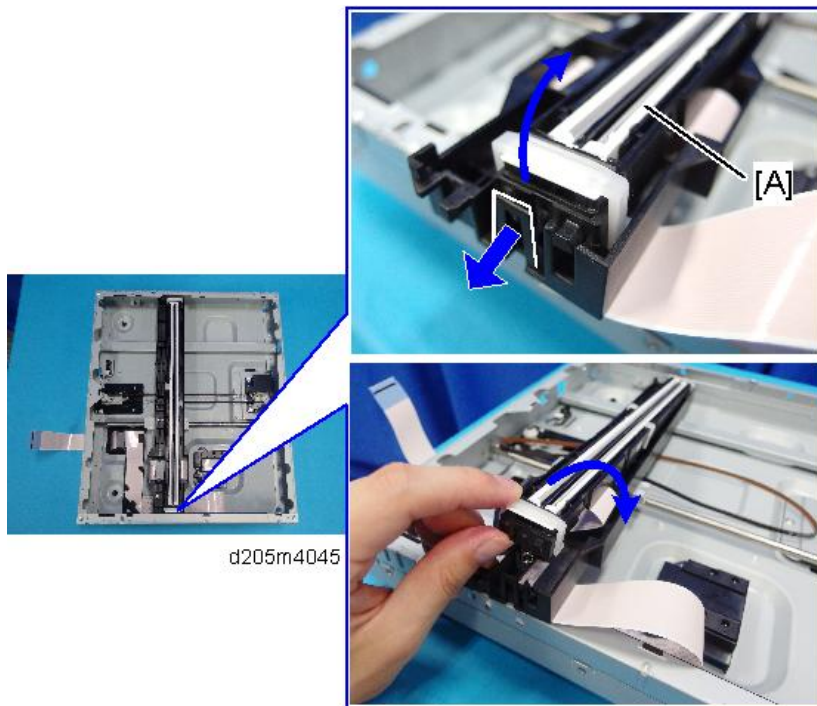

2. **CIS [A]**

Unlock the connector to release.

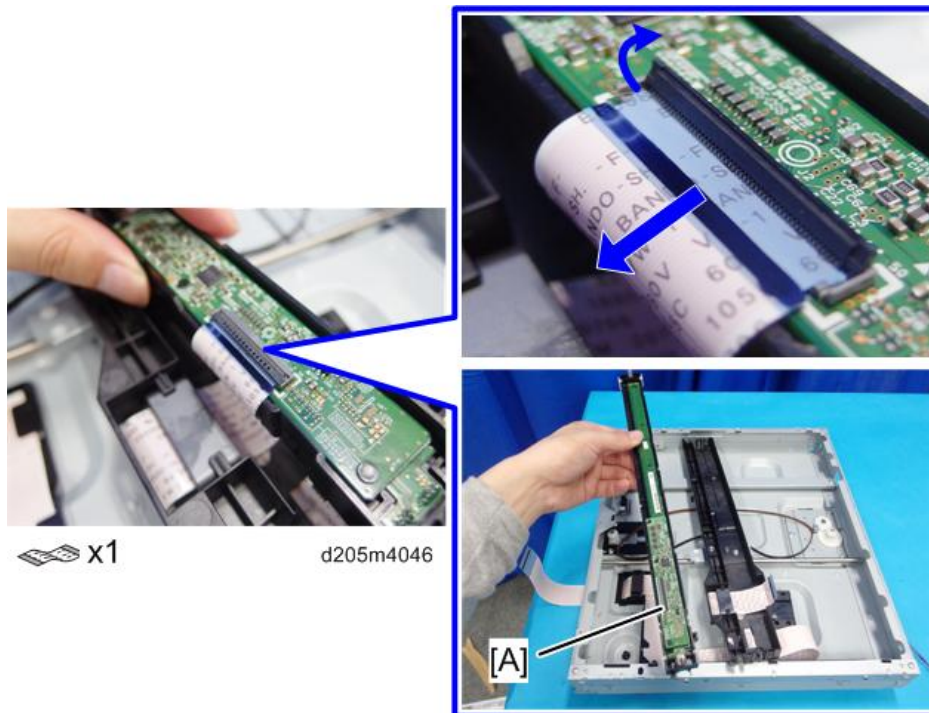

3. Adjust the vertical scanning with SP4-803-001 (HP Position Adjust).
4. Turn OFF then ON the main power to apply the SP setting.
5. Adjust the carriage parallel if necessary (page 3-49).

⬇ Note

- The CIS correction value is stored in an EEPROM on the BiCU. This correction value must be re-adjusted after the CIS unit is replaced.
  - SP4-008 (Sub scan magnification Adj)
  - SP4-010 (Sub scan registration Adj)
  - SP4-011 (Main scan Reg)
  - SP4-688-001 (DF density adjustment ARDF)

### 3.8.9 PLATEN COVER SENSOR, ARDF POSITION SENSOR

1. Rear cover (page 3-5)
2. Remove the following:
  1. Platen cover sensor [A]
  2. ARDF position sensor [B]

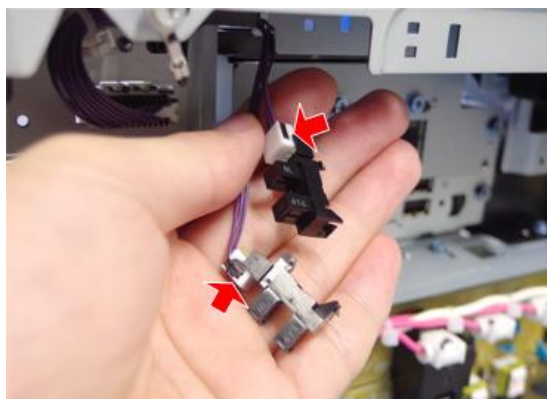
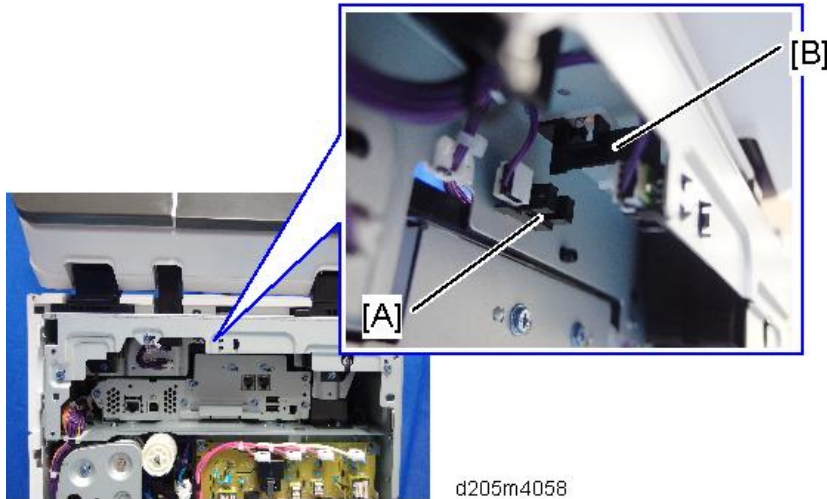

 x2

d205m4060

#### Note

- Remove the scanner unit to release the tabs that are inside the platen cover sensor.



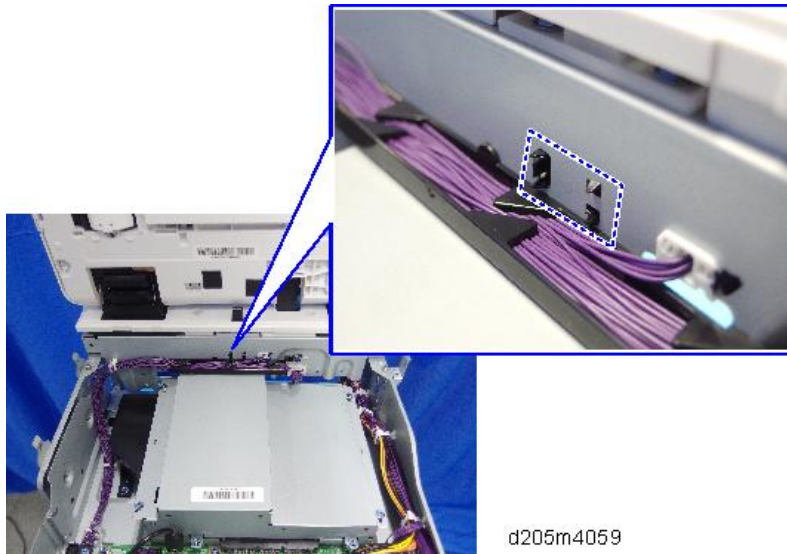

### 3.8.10 SCANNER PARALLEL ADJUSTMENT

Use the parallel pins to adjust the scanner skew.

#### 1. Cover of the scanner motor [A]

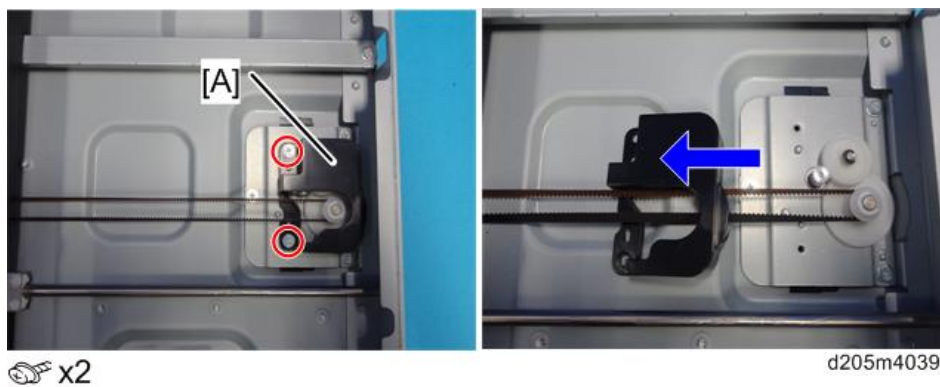

#### 2. Loosen the screw to release the tension.

#### 3. Timing belt [A]

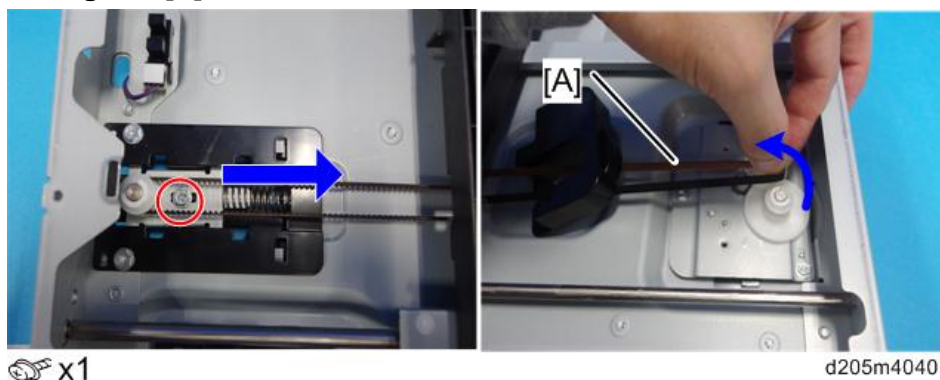

#### 4. CIS and screws

This is to allow you to adjust the position of the carriage at the Point [A].



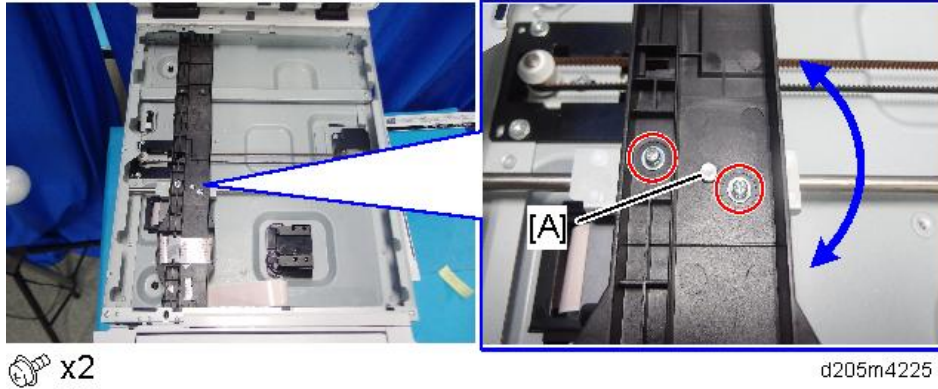

5. Move the carriage to the insertion position of the parallel pins.

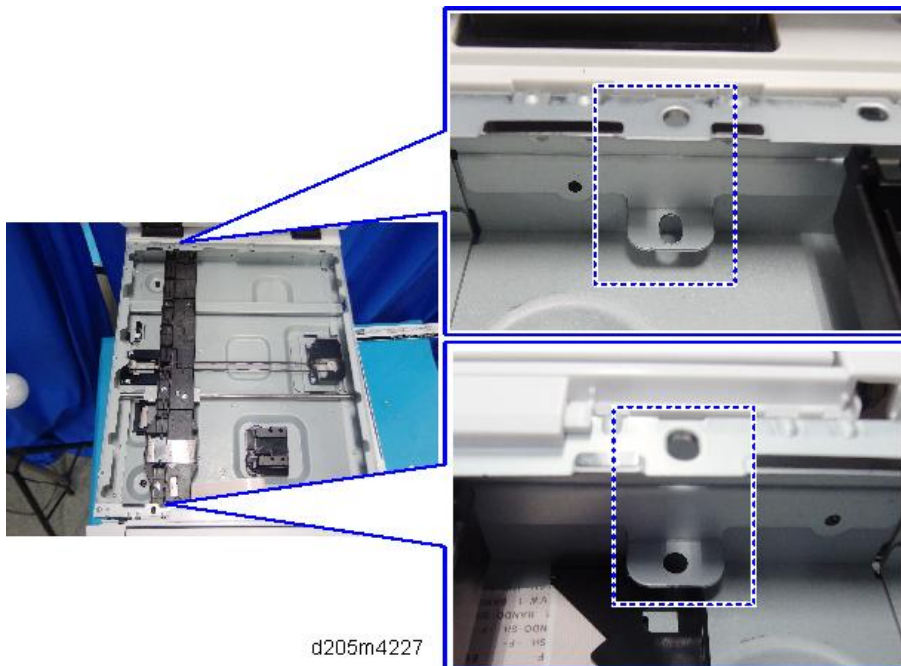

6. When the adjusting position of the carriage [A] is at the pin insertion position, insert the parallel pins [B].

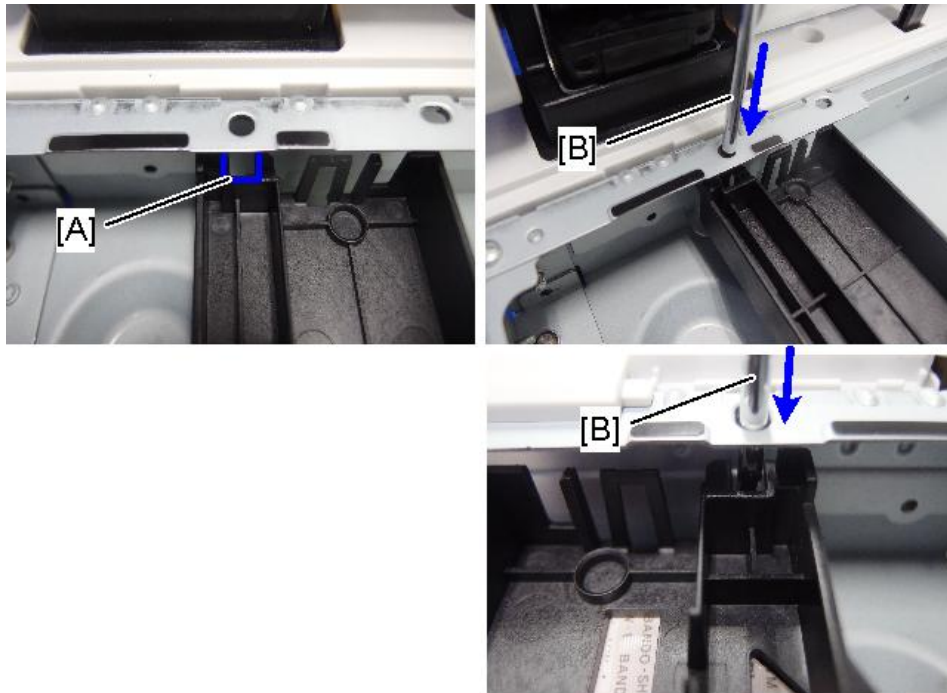

d205m4228

Replacement  
and Adjustment

## 3.9 LASER OPTICS

### 3.9.1 LOCATION OF THE CAUTION DECAL

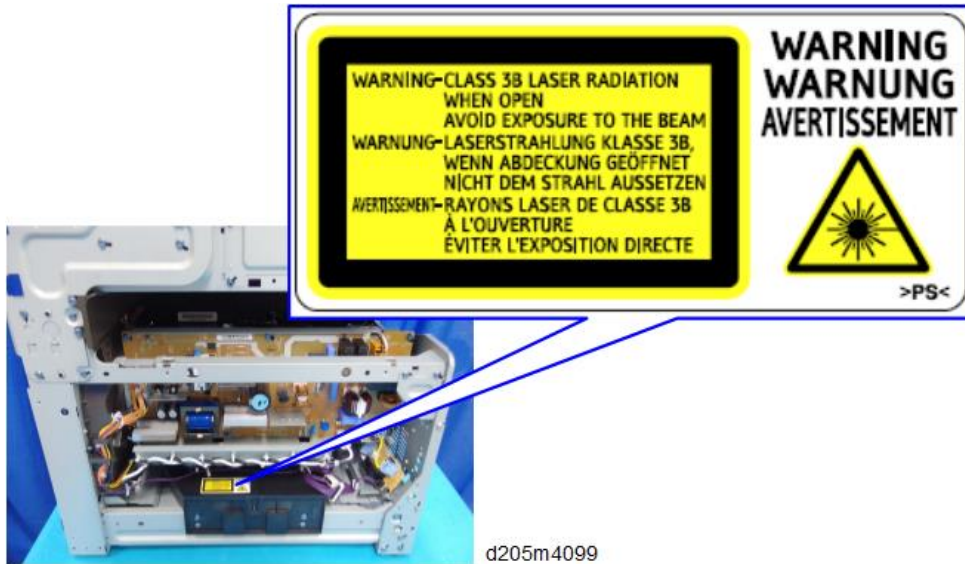

### 3.9.2 DUST-SHIELD GLASS

1. Open the front cover.
2. Small cover [A]

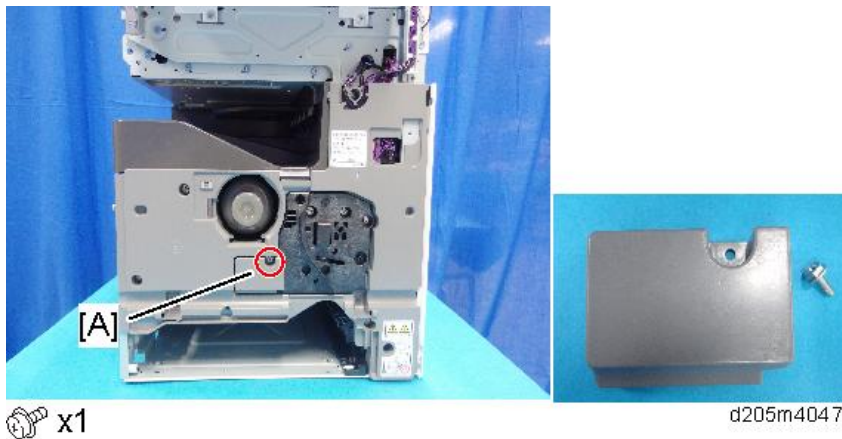

3. Pull out the dust-shield glass [A].

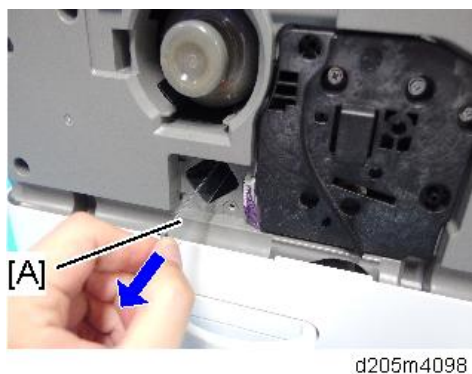

**Notes on Installing the Dust Shield Glass**

To check whether the glass is installed correctly, see the following:

**Correct:**

You can feel that the dust shield glass stops at a certain point while inserting the dust shield glass. You cannot push it in any more.

**Incorrect:**

You cannot feel that the dust shield glass stops while you are inserting it. You can insert the dust shield glass so far that it becomes completely hidden in the hole.

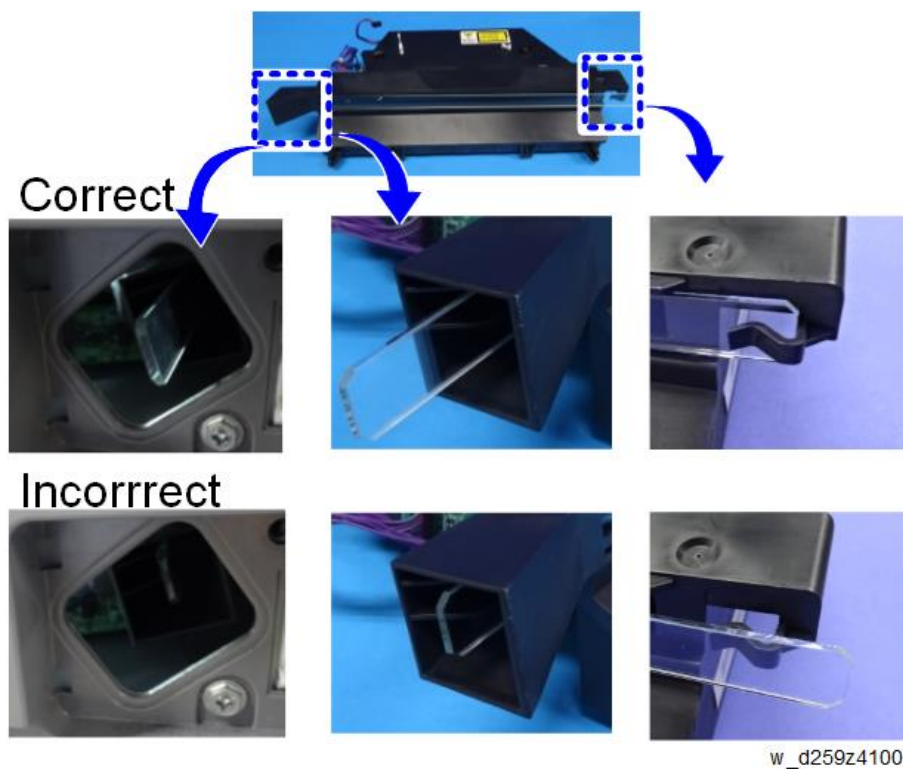

Replacement and Adjustment

### 3.9.3 LASER UNIT

#### 1. T-shaped cover [A]



#### 2. Screws of the rear cover [A]

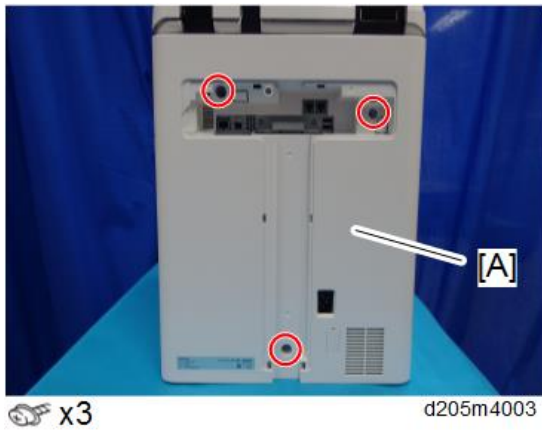

#### 3. Open the right cover. (tab x2)

#### 4. Rear Cover [A]



#### Note

- Be careful not to damage the tabs at the rear of the left cover when removing or installing the rear cover.



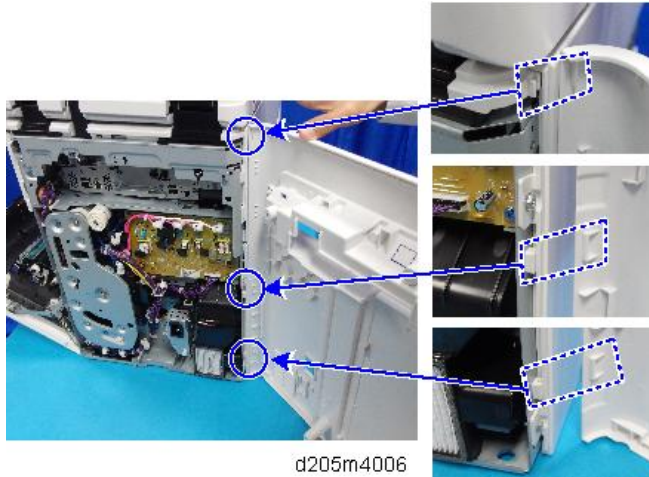

5. Open the front cover.
6. Front Upper Cover [A]



7. Open the ARDF.
8. Slide the left upper cover [A] toward front side (Positioning Boss [B]).

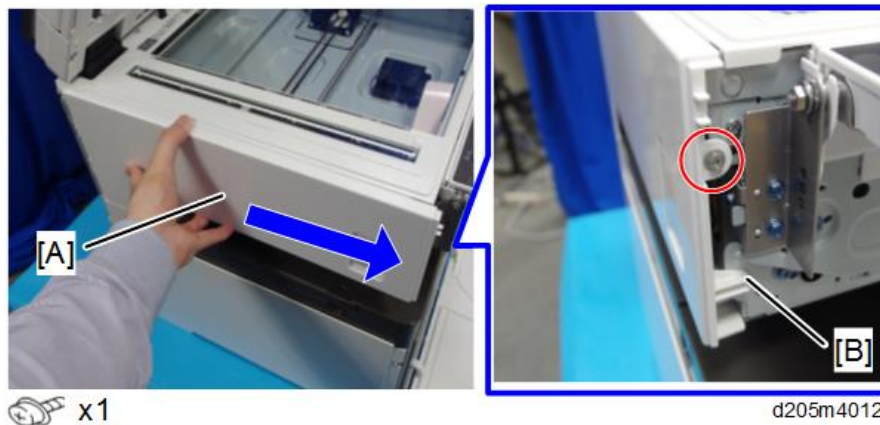

**Note**

- Be careful not to damage the two tabs at the rear when you remove or install.



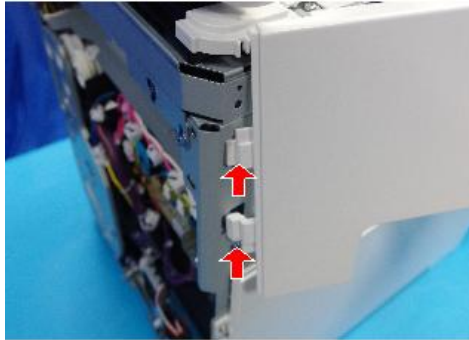

d205m4013

**9. Left lower cover [A]**

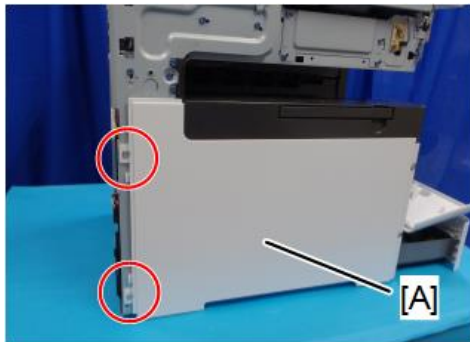

🔑 x2

d205m4014

**Note**

- To remove the left lower cover [A], slide to rear and be careful not to damage the positioning boss [B] and tabs.

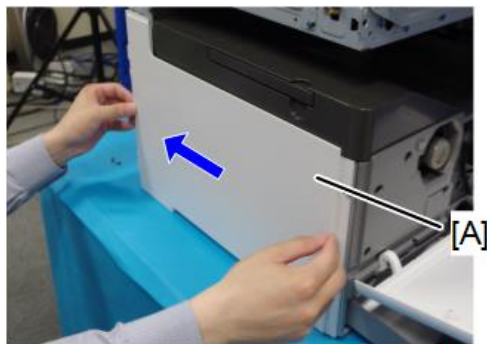

d205m4015

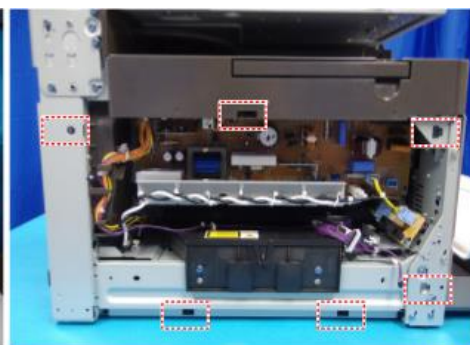
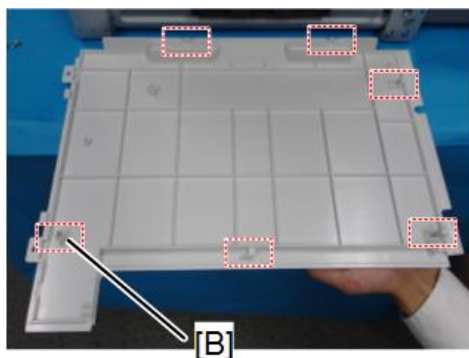

d205m4016

**10. Dust-shield Glass (page 3-52)**

**11. Pull out the laser unit halfway.**

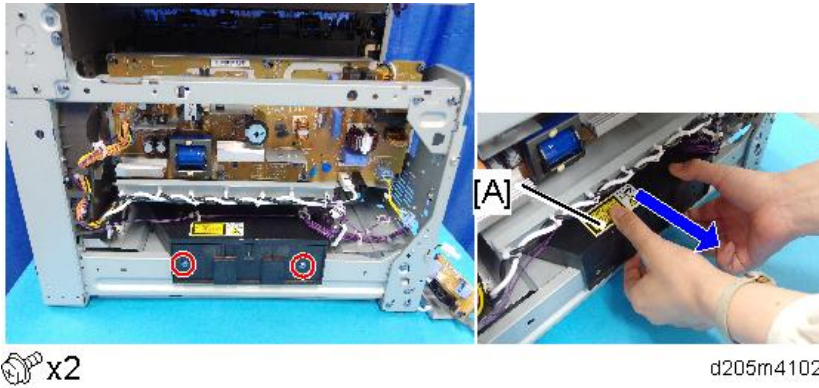

 x2

d205m4102

**12. Release the clamps and the connectors.**

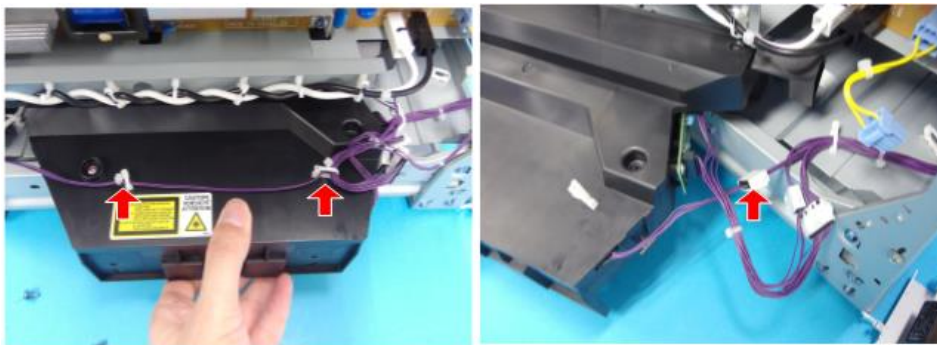

 x2  x1

d205m4103

**13. LDB [A]**

The LDB is attached to the laser unit, and can only be replaced at the same time as the laser unit.

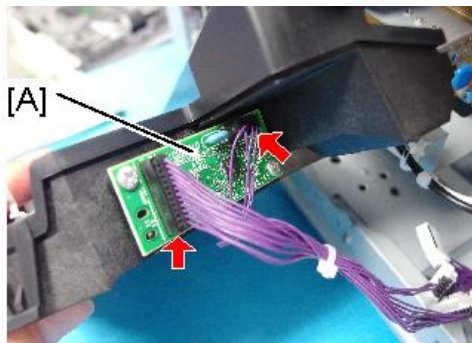

 x2

d205m4104

### ***Precaution for Installing the Laser Unit***

To prevent skew, first fit the positioning holes in the laser unit securely over the bosses on the machine, then tighten the screws to secure the laser unit.



d205m4229

### ***Parallelogram Image Adjustment***

The left upper screw [A] on the laser unit allows you to adjust the angle of the second mirror [B] to correct a parallelogram image.

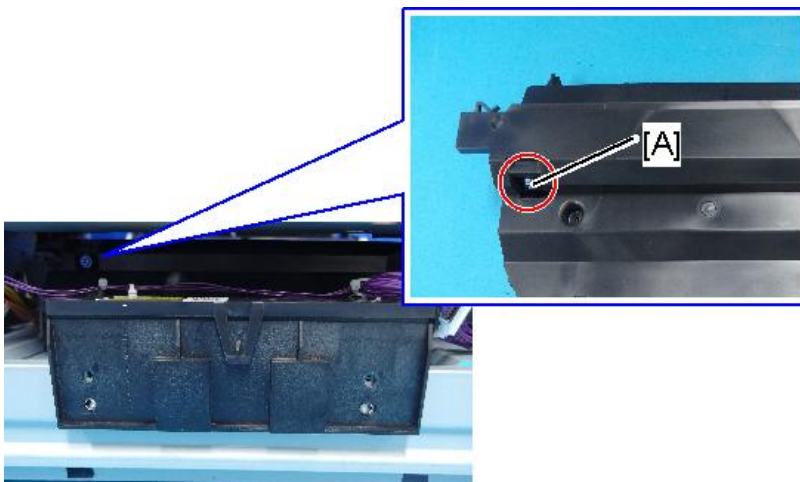

d205m4230

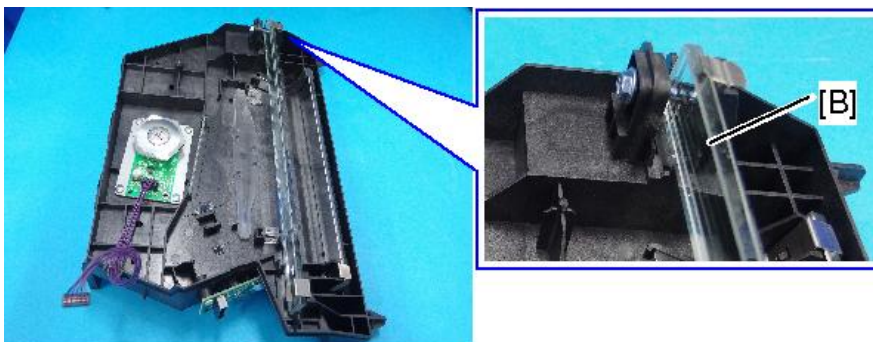

d205m4231

#### **Note**

- To correct the image [A], rotate the screw counterclockwise.
- To correct the image [B], rotate the screw clockwise.

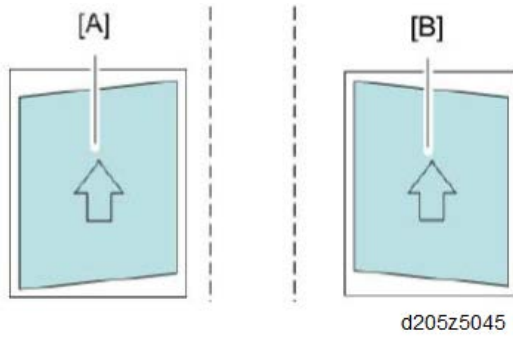

- Rotating the screw twice moves the image up/down 1 mm per 300 mm width.

## 3.10 PCDU

### ⓘ Note

- To prevent damage from toner spillage during the PCDU removal, be sure to place a ground cloth on the floor.
- To prevent damage from excess light, wrap the PCDU with protective paper and store the PCDU in a cool dark place.
- Do not touch the drum, cleaning blade or any seals with bare hands.
- Do not use any alcohols or solvents to clean the OPC drum; be sure to wipe with a dry cloth. If excess dirt exists, first wipe with a damp cloth, and next wipe off completely with a dry cloth.
- Do not rotate the PCDU clockwise after the PCDU has been installed.

### 3.10.1 PCDU

#### ⓘ Note

- When you take the new PCDU out of the box, hold the lower middle part of the PCDU. Otherwise, you will damage the drum unit and this will cause defective images.
- Remove the developer cap [A] from the new PCDU and put it on the old one. Attach the cap to the toner supply unit of the old PCDU that is in the box with the new PCDU enclosed.



d205z4055

- The PCDU has new unit detection. A flag in a chip in the TD sensor is overwritten when power is turned ON.
- The new PCDU is detected automatically, so it is not necessary to make any settings manually after installing a new unit.

1. **Open the front cover.**
2. **Small cover [A]**



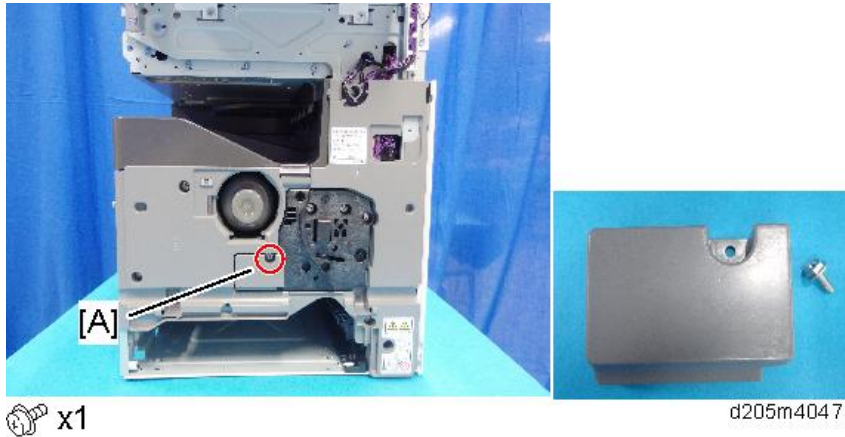

 x1

d205m4047

### 3. Open the right cover and remove the toner bottle.



#### Important

- Remove the toner bottle only while the PCDU is in the machine. If the toner bottle is taken out and/or put in while the PCDU is out of the machine, toner scattering may occur because of the bottle's internal pressure.

### 4. PCDU [A]

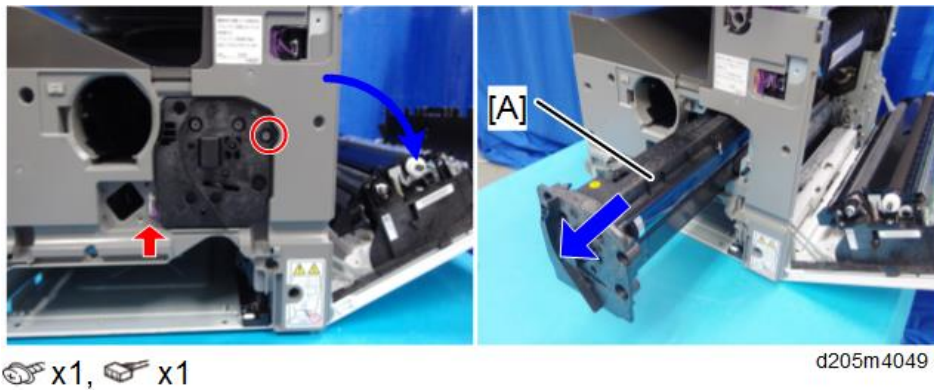
Do not touch the surface of the drum with bare hands.



 x1,  x1

d205m4049

### 5. Do the test after replacement (page 3-67).



### 3.10.2 TONER SUPPLY MOTOR

1. Rear Cover (page 3-5)
2. HVPS (page 3-125)
3. Harness holder [A]

★ Important

- Do not remove the bracket [B]. If it is removed, the harness may be damaged.

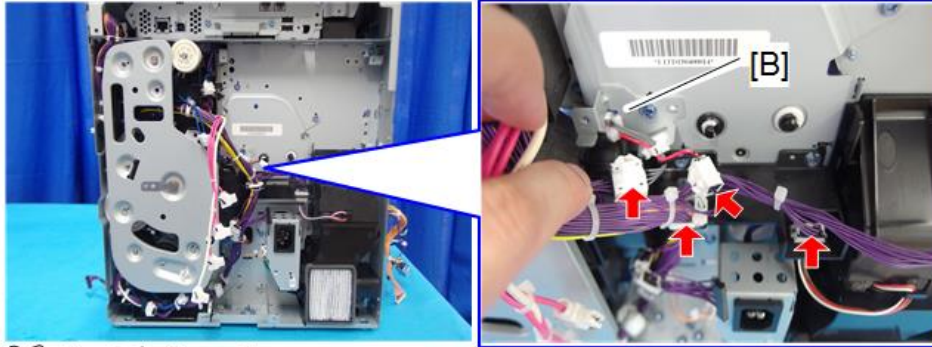

🔧 x2, 📦 x2, 📦 x4

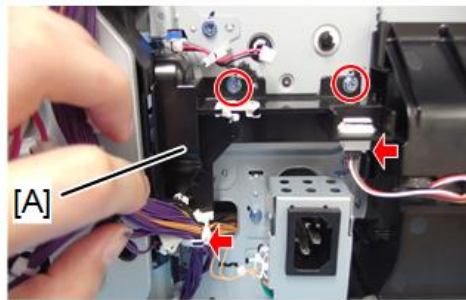

d205k4199

4. Supply unit [A]

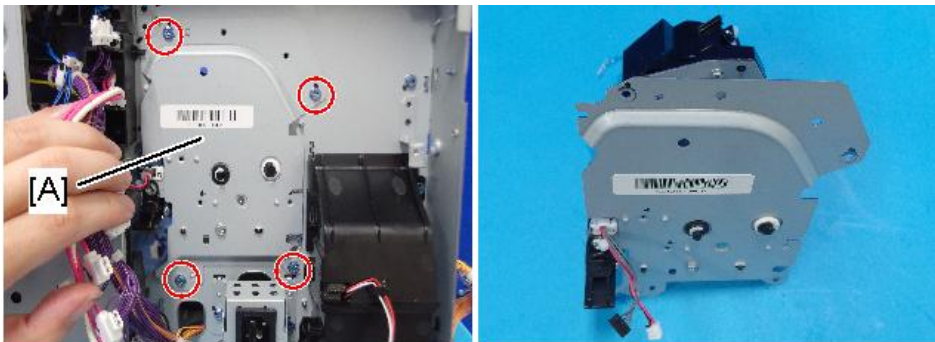

🔧 x4

d205m4201

5. Plate [A]

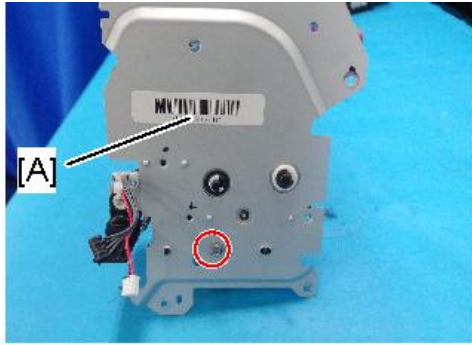

x1

d205m4211

**★ Important**

- Do not open the stopper [A], or toner will spill out.

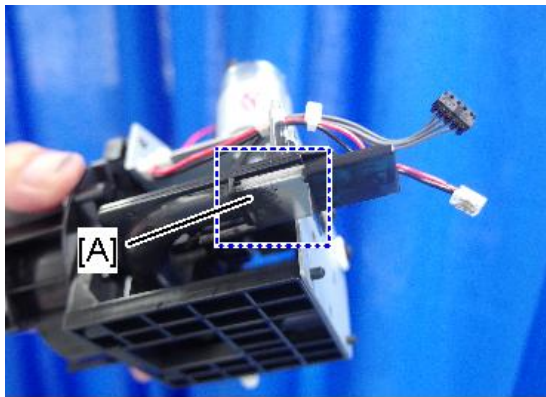

d205m4212

**6. Motor Bracket [A]**

**↓ Note**

- Do not remove the E ring [B]. If it is removed, the axis may be damaged and the unit should be changed.

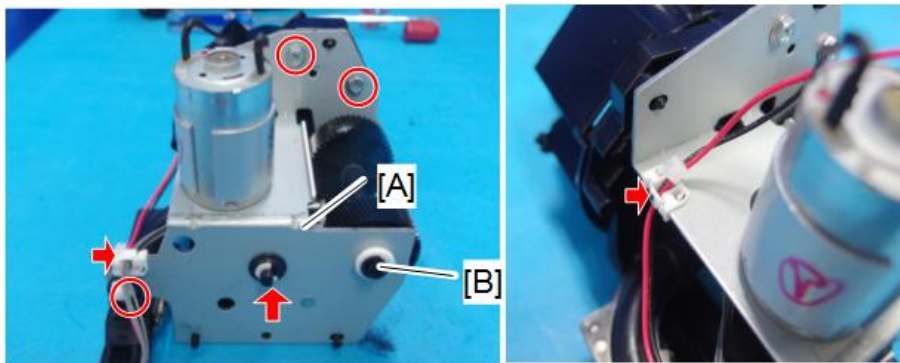

x3, x2, x1

d205k4213

**7. Toner Supply Unit [A]**

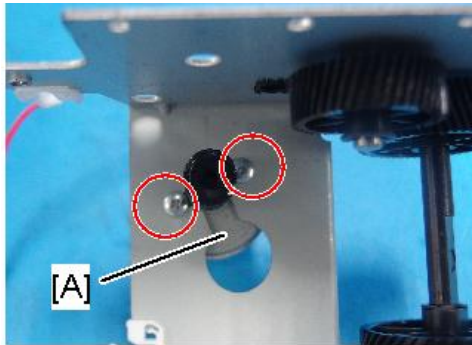

 x2

d205m4214

### 3.10.3 QUENCHING LAMP

1. PCDU (page 3-60)
2. Fusing unit (page 3-84)
3. Quenching lamp [A]

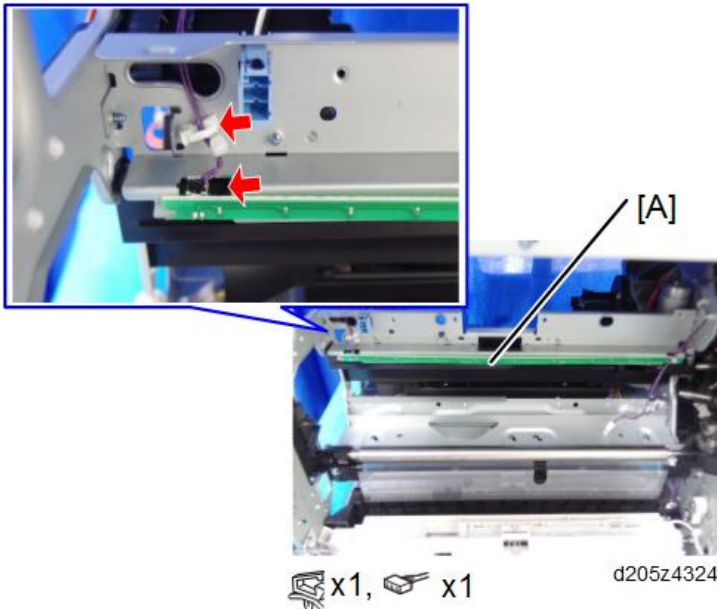

 x1,  x1

d205z4324

#### Note

- Bend and slide the quenching lamp [A] to remove as shown below.

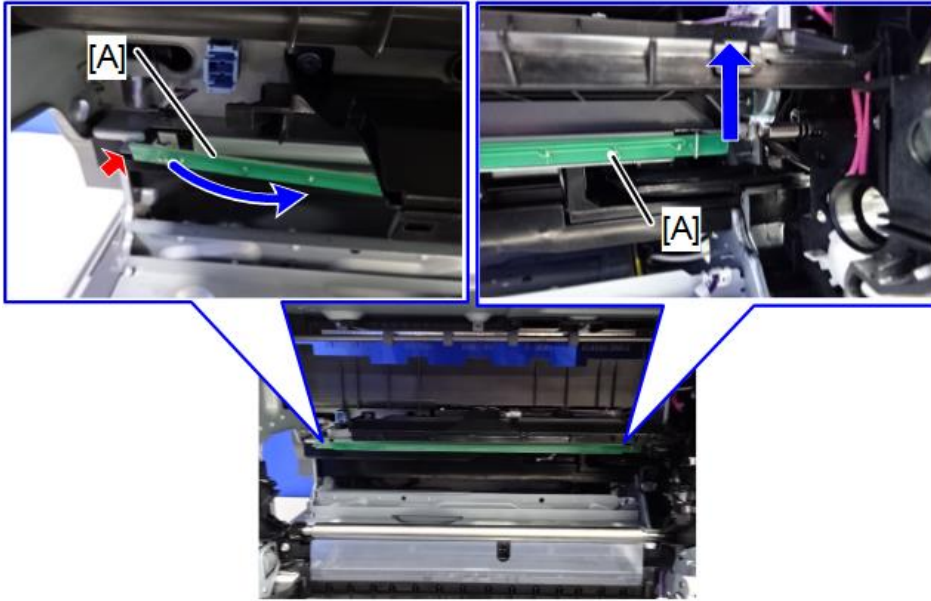

d205z4179

Replacement  
and Adjustment



### 3.10.4 TD SENSOR

**Preparation**

- Make sure that the toner supply port [A] has been covered before performing any steps in this section.

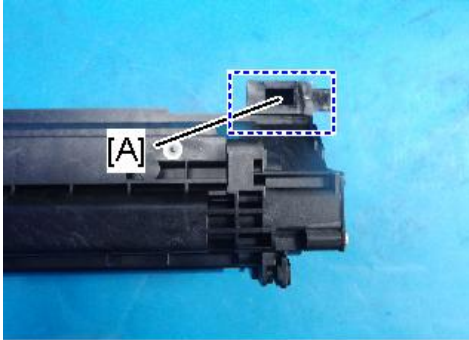

d205m4224

- PCDU (page 3-60)
- Sensor cover [A]

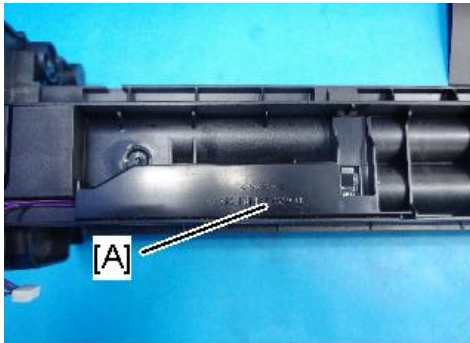

d205m4222

- TD Sensor [A]

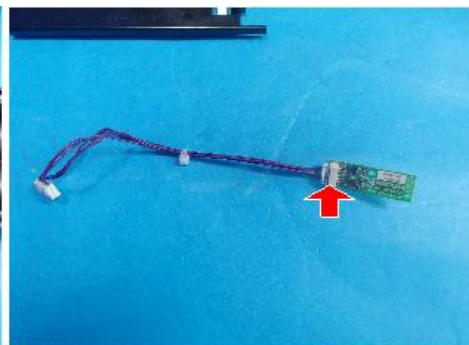
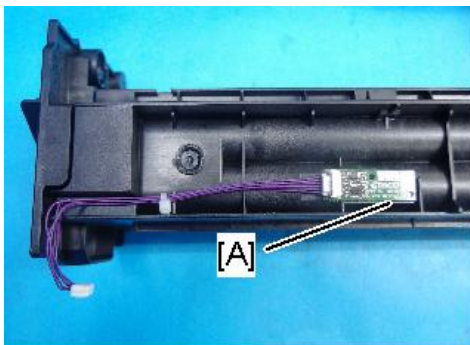

x1

d205m4223

### 3.10.5 TEST AFTER REPLACING THE PCDU

After replacing the PCDU, do the following procedure.

1. **Take 5 sample copies.**
2. **If black dots show on any of the copies, continue as follows.**
  - If all copies are clean, skip the following steps.
  - If the drum unit is damaged, black dots appear (while changing parts, make sure to not damage the drum unit).
3. **Remove the PCDU.**
4. **Tap the top of the PCDU with a screwdriver at eight evenly spaced locations (two or three taps at each spot), to knock the recycled toner down into the development section.**
5. **Re-install the PCDU.**
6. **Turn ON the main power. Then open and close the front cover and wait until the machine has rotated the development roller for 10 seconds.**
7. **Open and close the door two or three more times, so that the total rotation time is 30 seconds.**
8. **Make some solid black prints.**
  - If using A4 or 8<sup>1</sup>/<sub>2</sub>" paper, make 4 copies/prints.
  - If using A3 or 11" x 17" paper, make 2 copies/prints.
  - To make solid black prints, use SP2-109-001 pattern 20.



## 3.11 PAPER FEED

### 3.11.1 PAPER FEED ROLLER, FRICTION PAD

1. Paper Feed Tray
2. Bearing



 x1

d205m4217

3. Paper feed roller [A]

Hold under the roller and remove the roller.

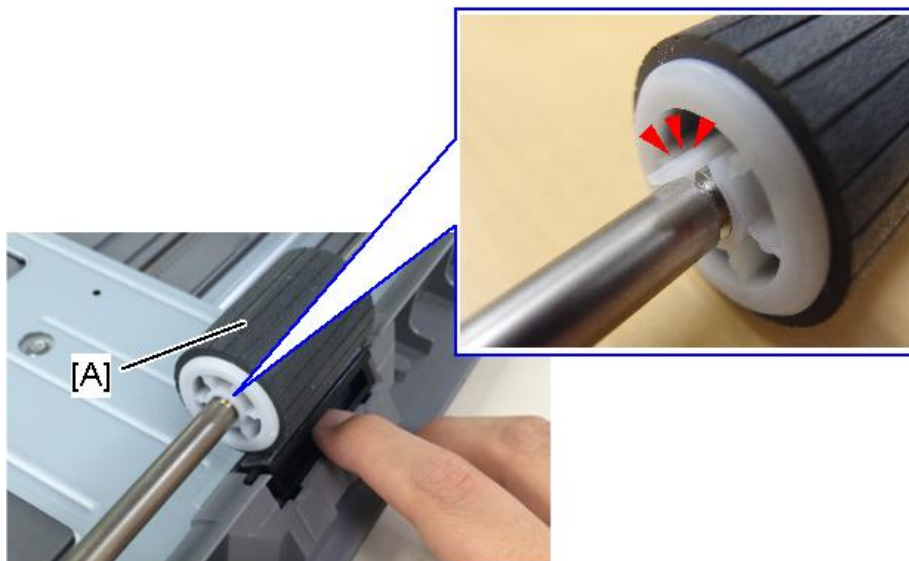

d205m4219

4. Friction pad [A]

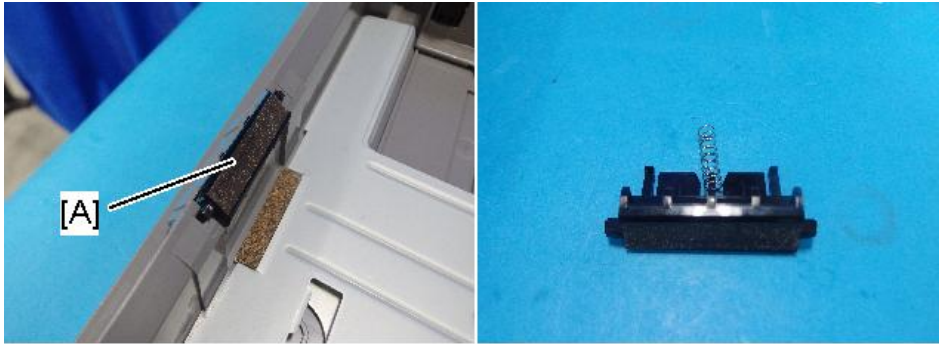

d205m4221

### ***Notes on Replacing the Friction Pad***

Make sure that the sheet does not go under the friction pad when reinstalling the friction pad. ([A] Incorrect, [B] Correct)

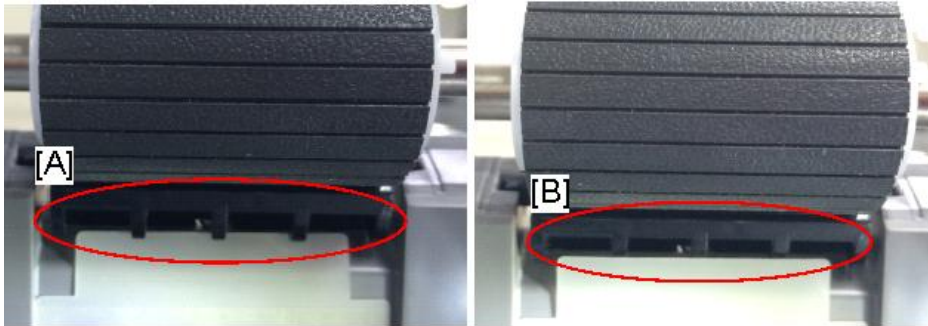

d205m4220

Do not touch the friction pad with your bare hands when replacing it. If you do, clean the friction pad with a damp cloth or alcohol.

### 3.11.2 PAPER DUST COLLECTOR

1. Paper feed tray
2. PCDU (page 3-60)
3. Open the right cover [A] and remove the clip ring and E-ring.

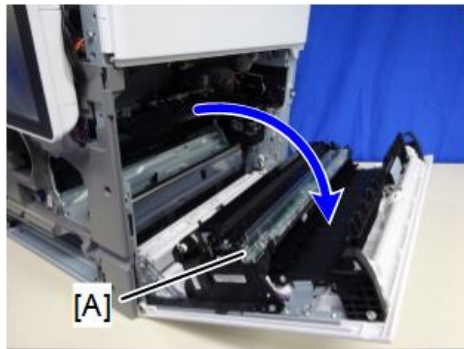

**Note**

- Do not open the right cover [A] more than 90°.

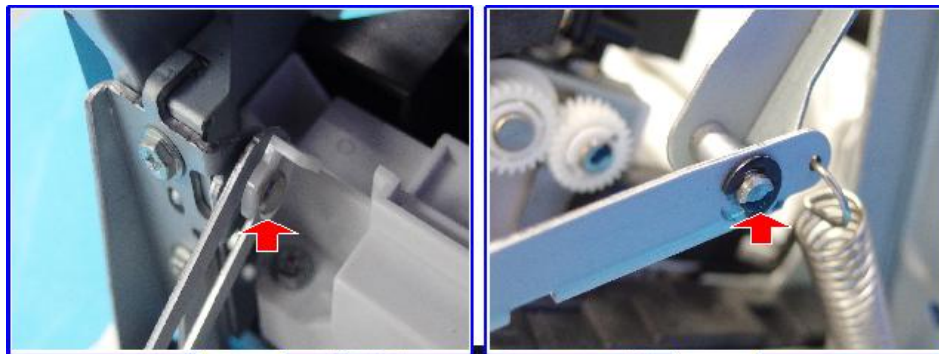

d205z4183



 x1,  x1

d205m4166

#### 4. Guide plate [A]

Lift the guide plate [A] as shown below.

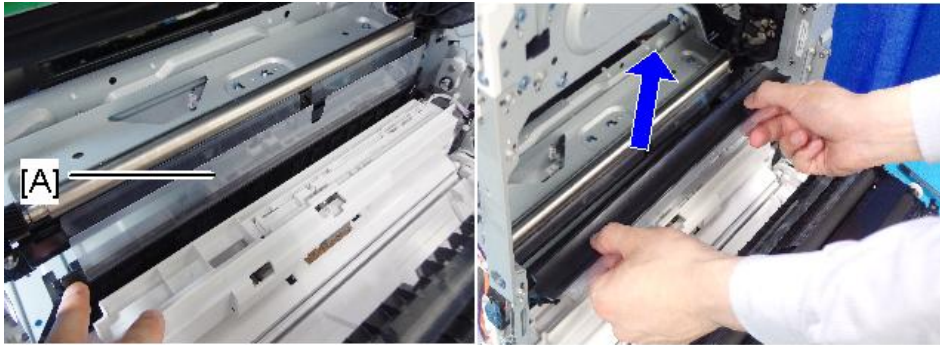

d205m4179

5. Paper dust collector [A].

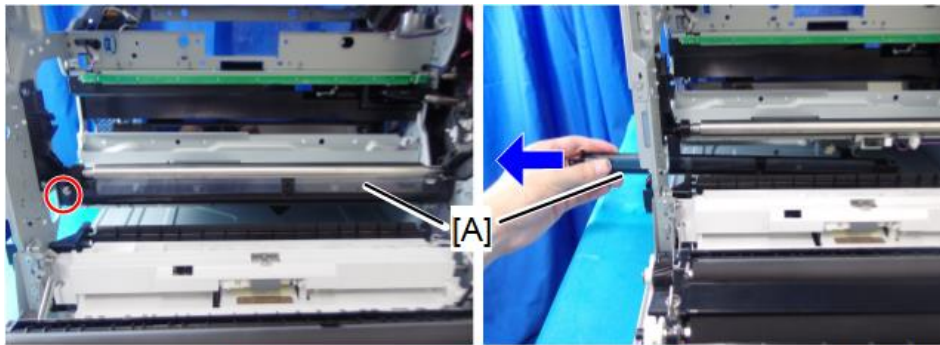

 x1

d205m4180



Replacement and Adjustment

**Notes on Installing the Paper Dust Collector**

Make sure that the bosses on the paper dust collector fit correctly into the rear frame of the machine.



d205m4181

### 3.11.3 REGISTRATION SENSOR

1. Paper dust collector (page 3-70)
2. Registration sensor

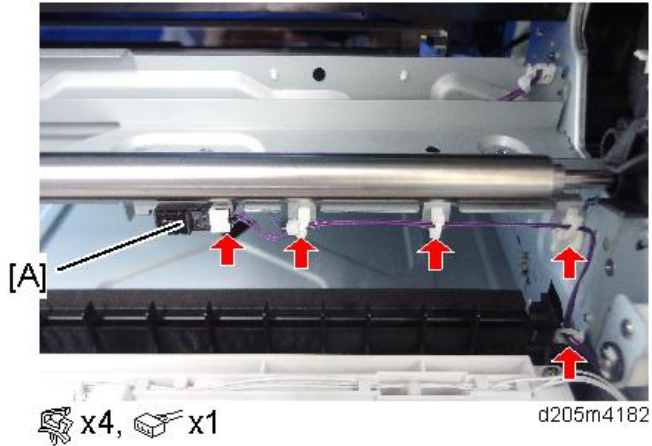

**Note**

- When installing the registration sensor, make sure that the sensor is connected.

#### ***How to Clean the Registration Sensor***

Remove the paper dust or dirt on the lens.

If it is difficult to clean, remove the paper dust collector.

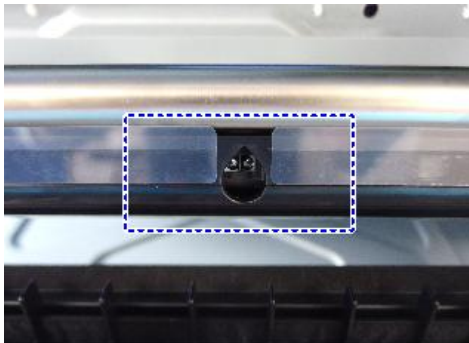

d205m4184



### 3.11.4 PAPER END SENSOR

1. Remove the paper feed tray.
2. Open the right cover [A] and remove the clip ring and E-ring.

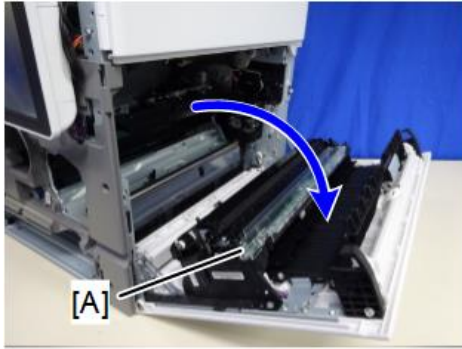

**Note**

- Do not open the right cover [A] more than 90°.

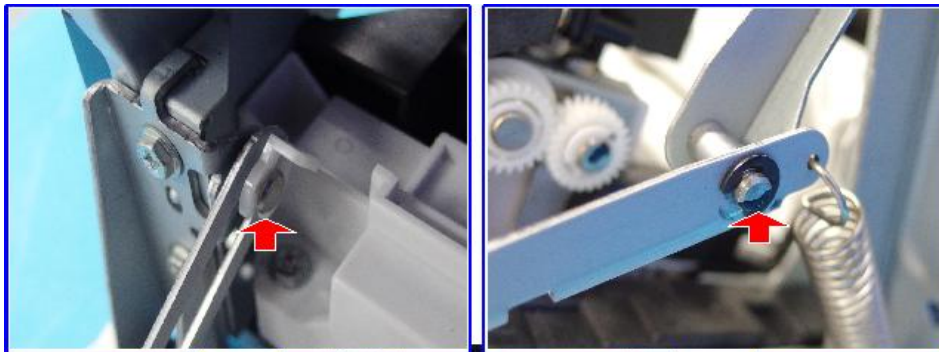

d205z4183





 x1,  x1

d205m4166

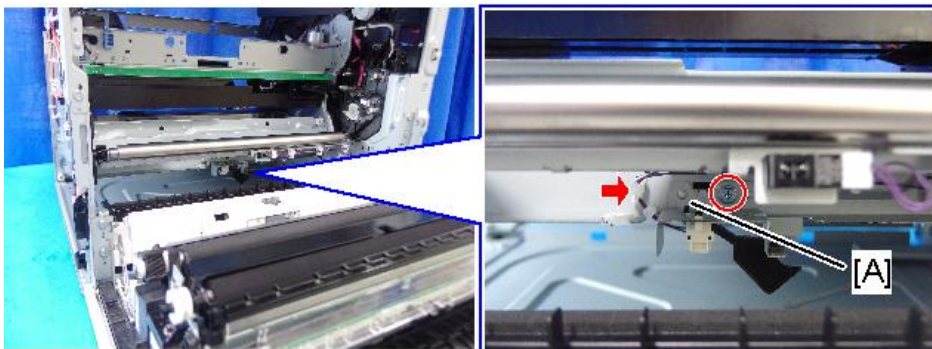
3. Sensor bracket [A]





 x1,  x1

d205m4183

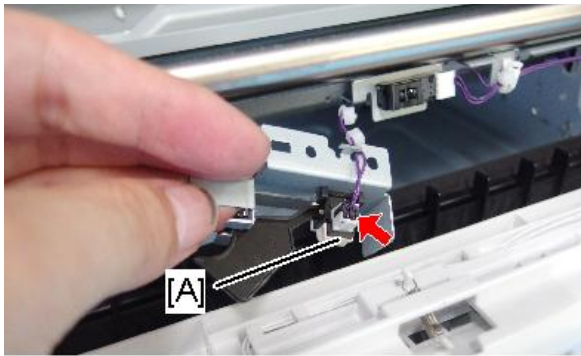

4. Paper end sensor [A]





 x1

d205m4184

### 3.11.5 REGISTRATION CLUTCH, PAPER FEED CLUTCH

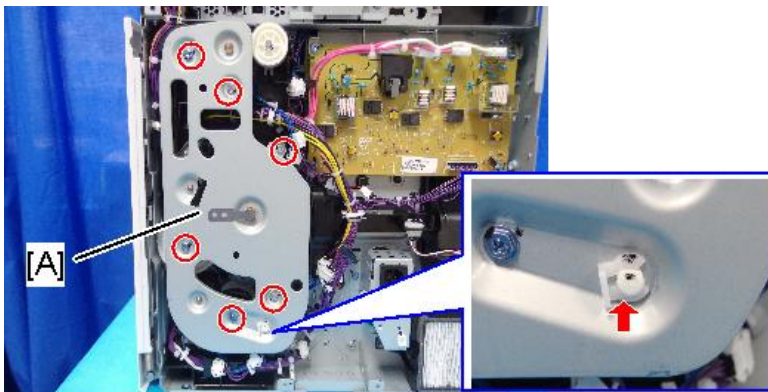
1. Rear cover (page 3-94)
2. Gear bracket [A]



 x6,  x1

d205m4160

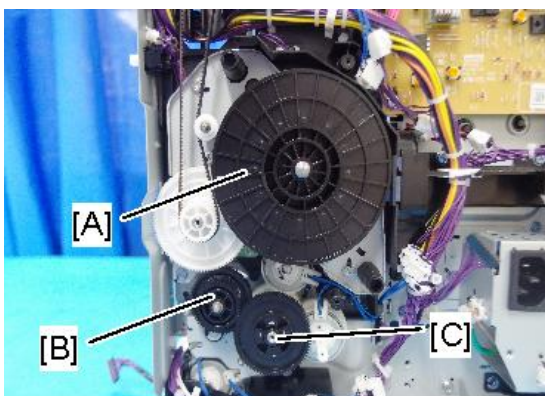

3. Gears [A] [B] [C]

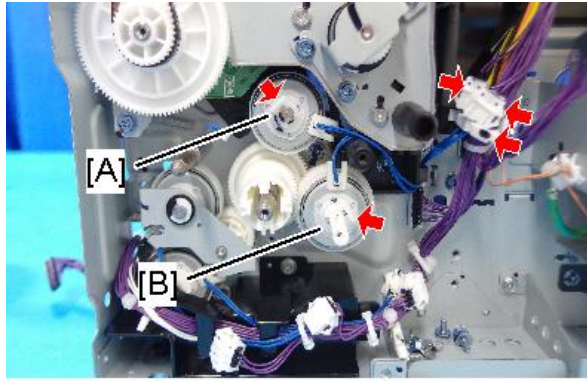

d205m4187

4. Registration clutch [A], and paper feed clutch [B]



 x1,  x2,  x2

d205m4188

### 3.11.6 REGISTRATION ROLLER

#### *Registration Roller (main machine side)*

1. Front inner cover (page 3-12)
2. Registration clutch (page 3-74)
3. Remove the bearing [A] at the rear side of the registration clutch and the front side of the machine.

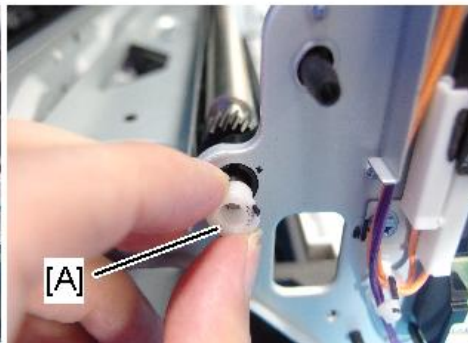
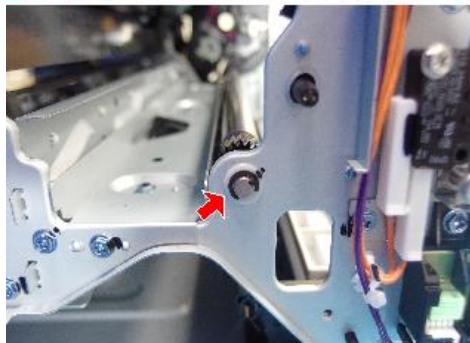
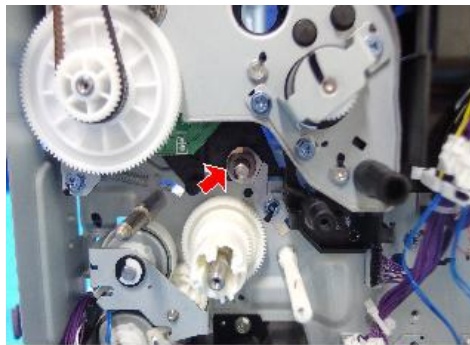

 x1

d205m4189

4. Registration roller [A]

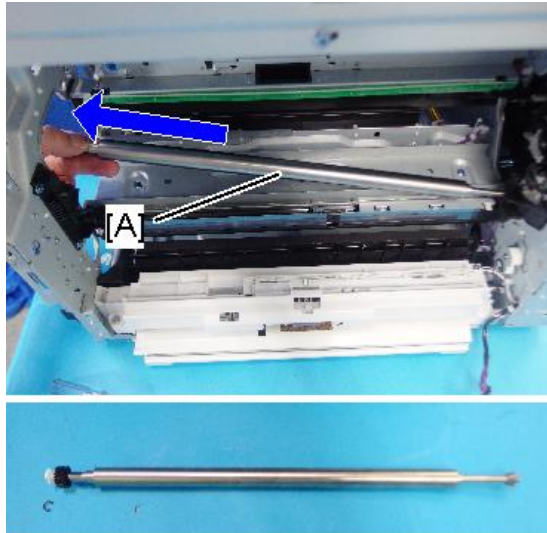

d205m4190

### ***Registration Roller (right cover side)***

1. Open the right cover [A] and remove the clip ring and E-ring.

**Note**

- Do not open the right cover [A] more than 90°.

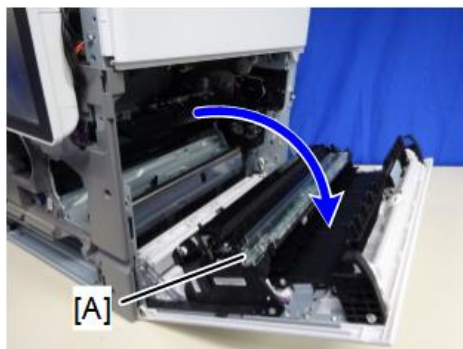

d205z4183

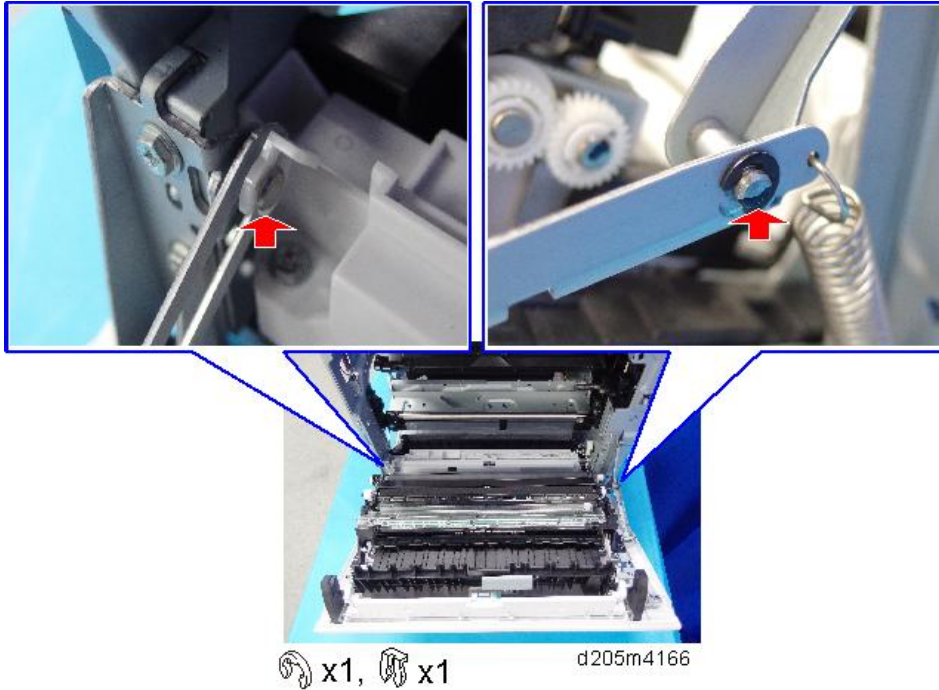

2. Remove bearings [A], gear [B], and holders [C] at both ends of the registration roller. The holder at the front end is white, and the one at the rear end is black.

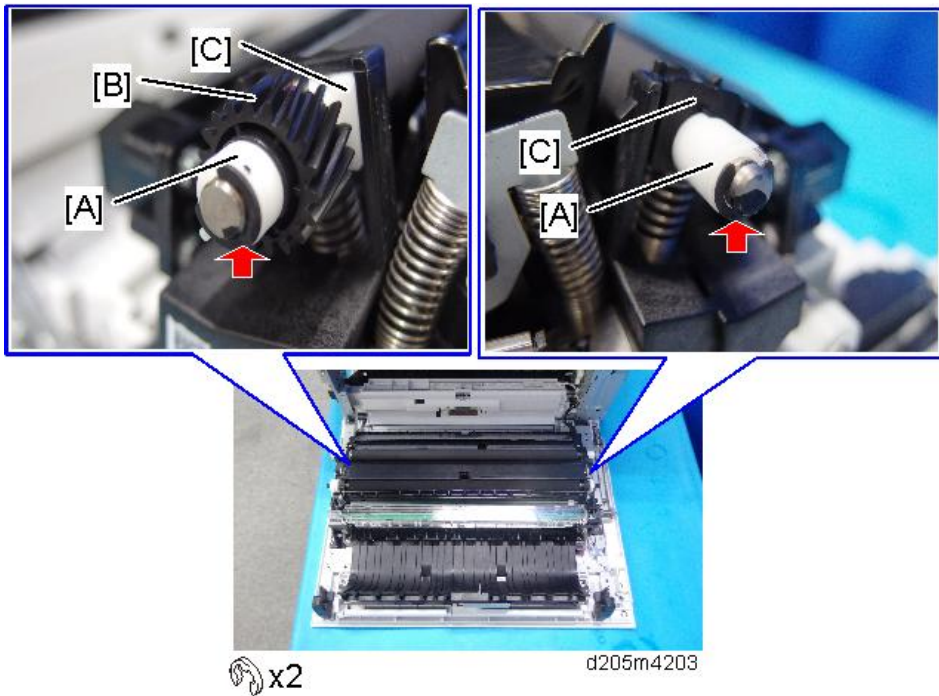

3. Registration roller [A]



## Paper Feed

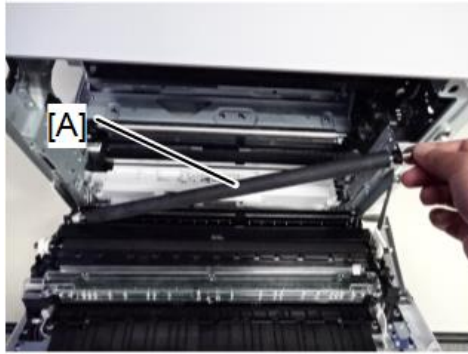

d205m4204

### ***How to Clean the Registration Roller***

Wipe the right cover side area with a damp cloth.

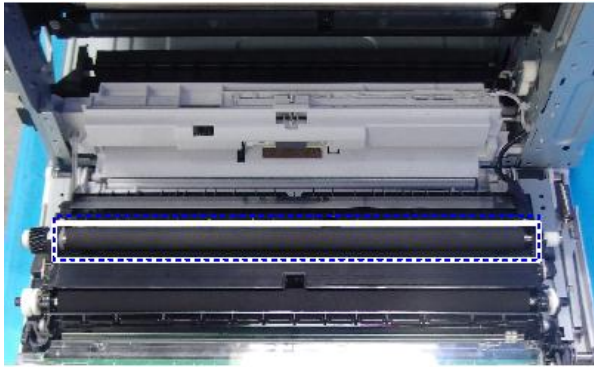

d205m4206

## 3.12 TRANSFER UNIT

### 3.12.1 TRANSFER ROLLER UNIT

#### ⓘ Note

- The transfer roller unit consists of a transfer roller and a discharge plate. It is not possible to replace the transfer roller alone.
- Do not touch the transfer roller surface with bare hands.

1. Open the right cover.
2. Release the tabs of the transfer roller unit [A].

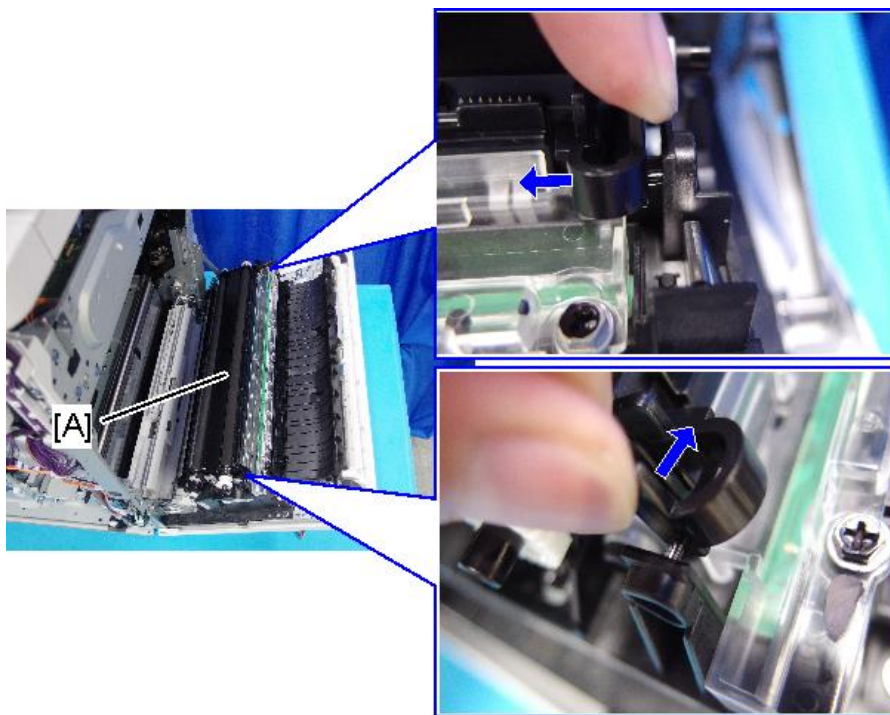

d205m4150

3. Transfer roller unit [A]

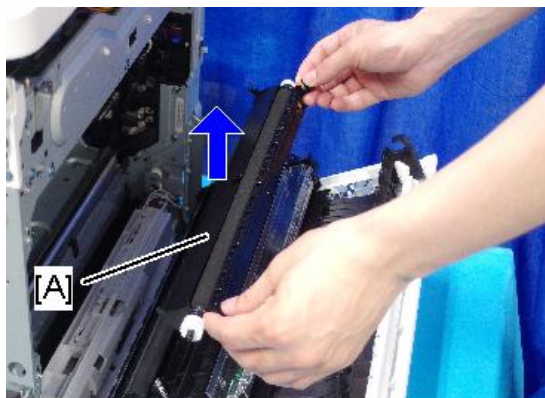

d205m4151

4. Enter the SP mode.
5. Do SP7-622-115 to clear the counter.



### 3.12.2 NOTES ON INSTALLING THE TRANSFER ROLLER UNIT

Check the back side of the transfer roller unit.

**Important**

- Make sure that the transfer roller unit holder [A] fits into the boss.

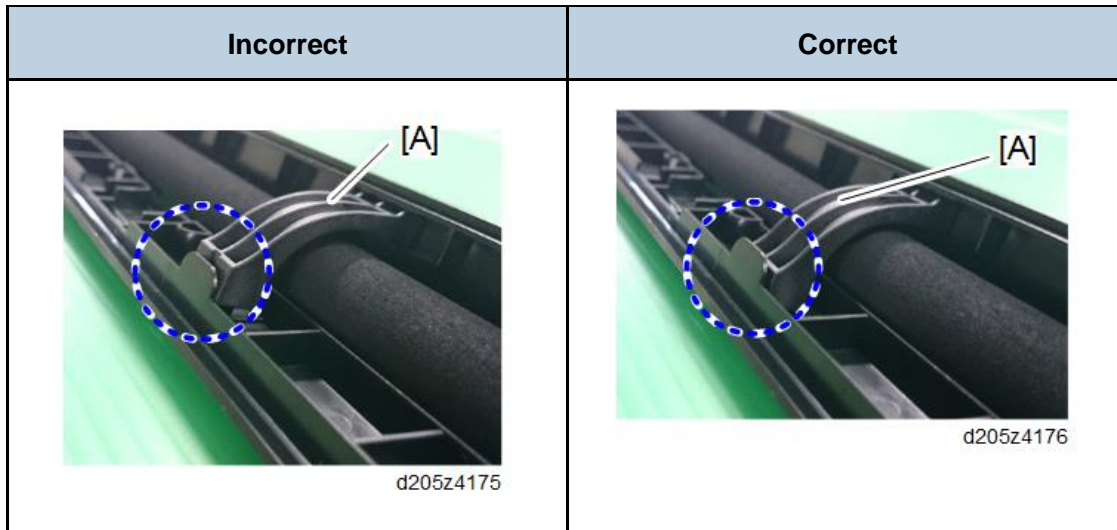

Then, turn the transfer roller unit upside-down. Check that there is no bend on part [A] and part [B].

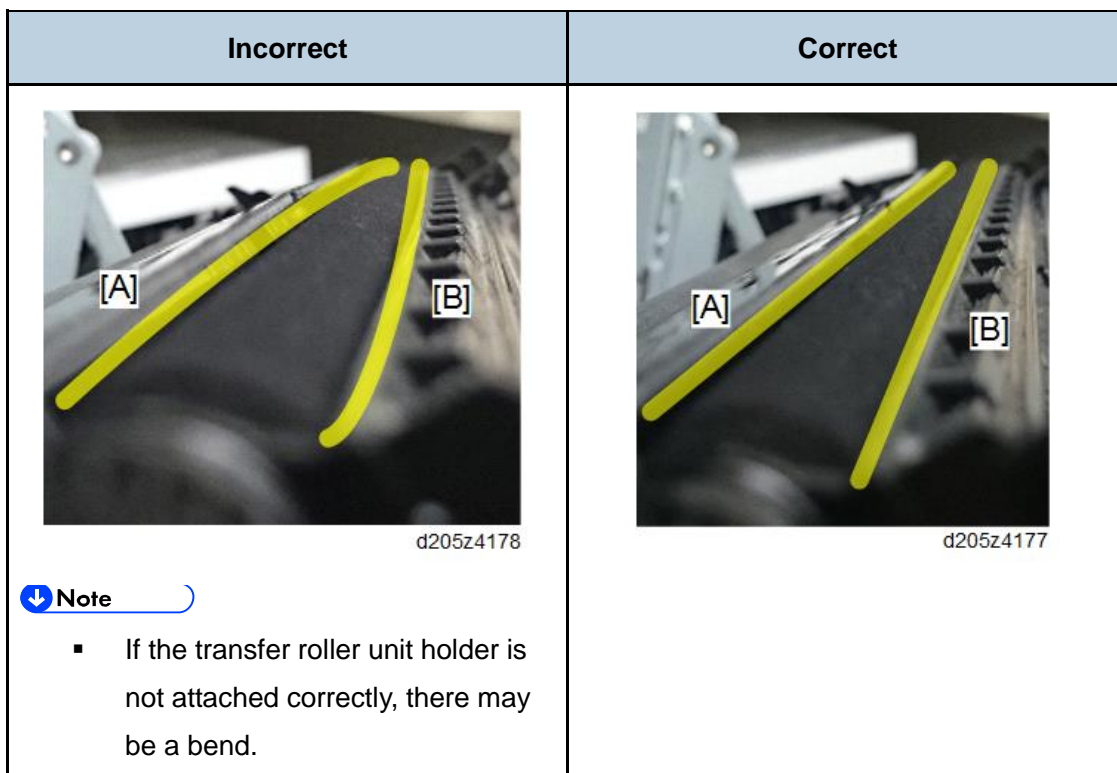

To install the transfer roller unit, check that the roller is correctly installed as explained below.

- Check that the tabs [A] are engaged in the cutouts.

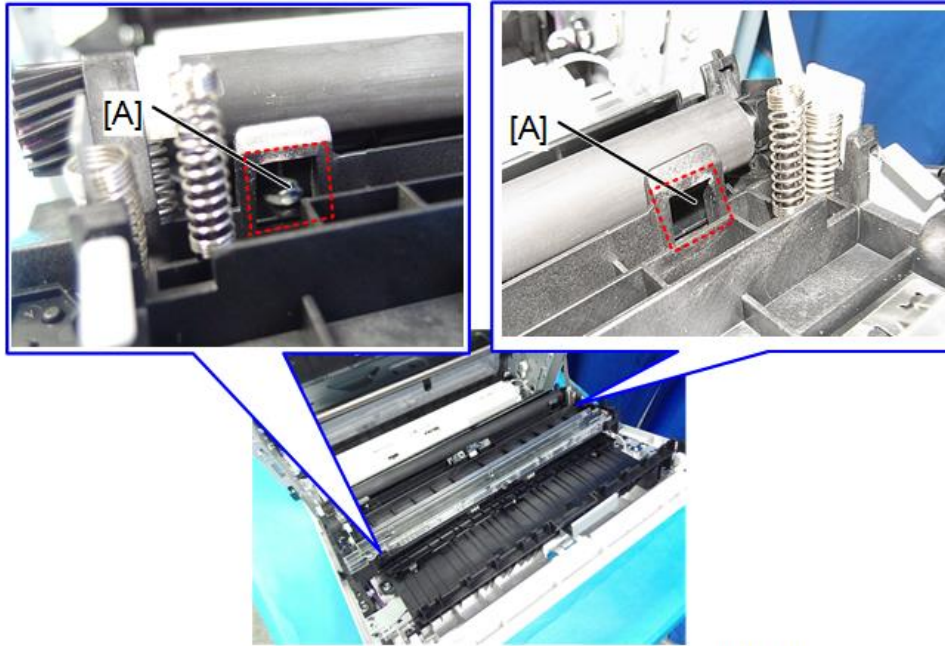

d205k4305

2. Check that the pins on both sides of the transfer roller unit are engaged correctly.

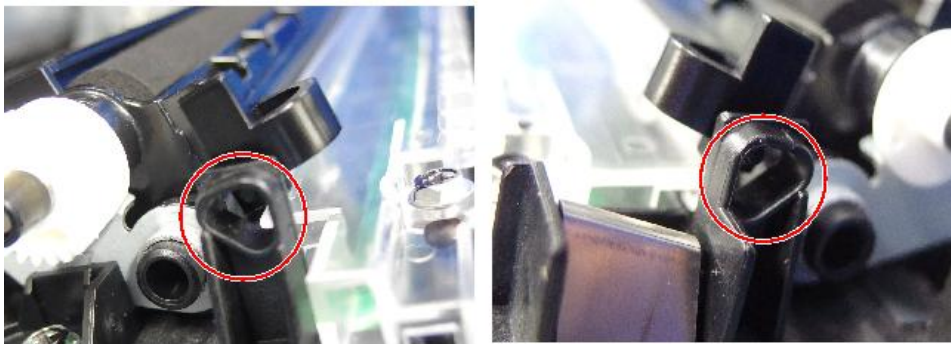

d205m4306

### 3.12.3 ID SENSOR

1. Transfer roller unit. (page 3-79)
2. Bracket [A]

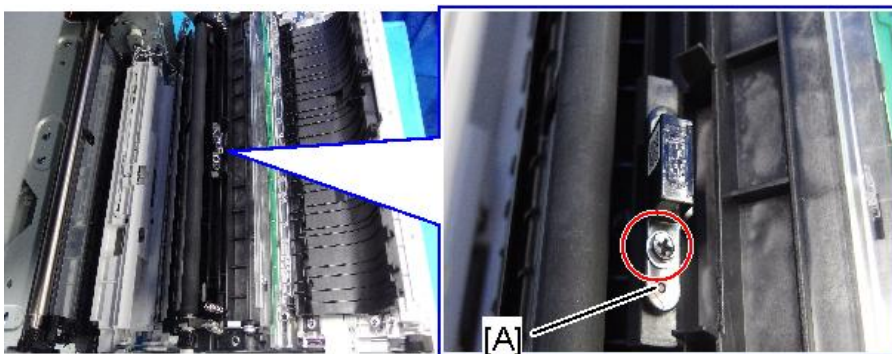

 x1

d205m4152

3. ID sensor [A]



 x1

d205m4153

### ***How to Clean the ID Sensor***

When cleaning the ID sensor, wipe the sensor part with a damp cloth.

Do not wipe it with a dry cloth. Otherwise, the ID sensor will attract dirt because of static electricity.

### 3.12.4 PCL (PRE CLEANING LAMP)

1. Transfer roller unit (page 3-79)
2. Plastic cover [A]

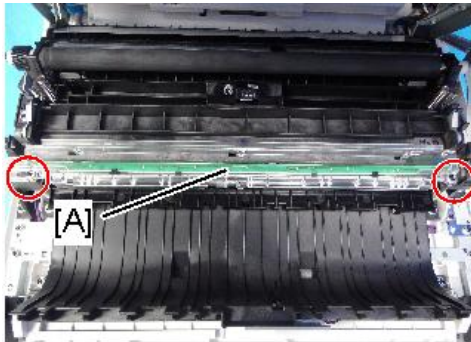

 x2



d205m4154

3. PCL [A]

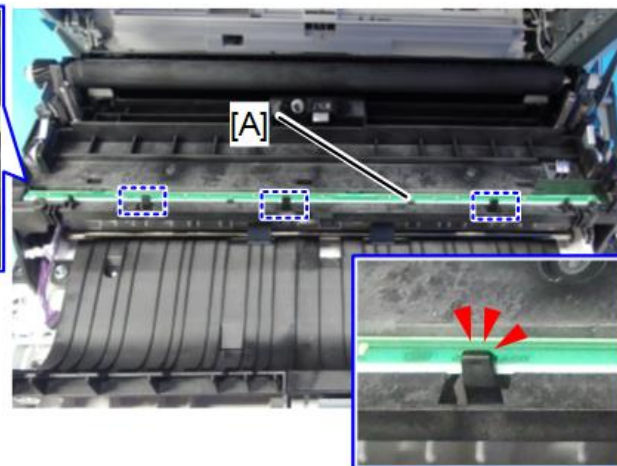

 x1

d205z4155

#### Note

- Be very careful not to break the three hooks when removing the PCL. Since the three hooks grab the PCL hardly, they can be broken easily when you remove the PCL.
- To remove the PCL safely, slide the PCL a little toward the front side of the machine to remove the connector first. This will make the PCL warped temporarily but there is no problem. Then, remove the PCL along with the guide (hooks).

#### ***How to Clean the PCL***

When cleaning the plastic cover of the PCL, wipe it with a damp cloth.

Do not wipe it with a dry cloth, or it may attract dirt because of static electricity.



## 3.13 FUSING UNIT

### ⚠ CAUTION

- Turn OFF the main power and wait until the fusing unit cools down before beginning any of the procedures in this section. The fusing unit can cause serious burns.
- Be careful not to drop the fusing unit when removing it.

### 3.13.1 CAUTION DECAL LOCATION



#### ↓ Note

- When removing a jammed paper from the fusing unit, wait until the fusing unit cools down.

### 3.13.2 FUSING UNIT

#### 🔧 Preparation

- Right cover should be removed before doing this procedure.(page 3-94)

1. Open the front cover.
2. Small cover [A] and connectors.



🔧 x1, 📦 x2

d205m4094

3. PCDU (page 3-60)
4. Duct [A] located under the fusing unit in the mainframe.

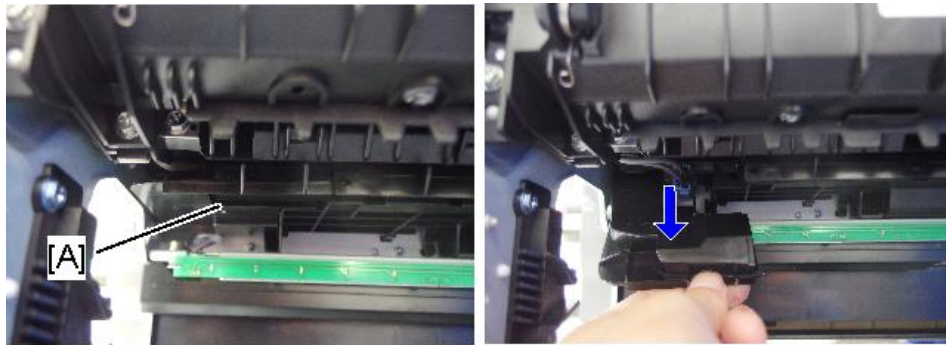

d205m4232

5. Connector [A]

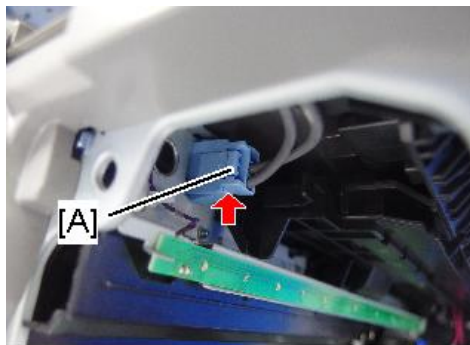

x1

d205m4233

**Important**

- This connector is a locking connector. Pull out the connector while pushing the releasing point [A] with your fingers.

6. Screws on the fusing unit [A] with washers

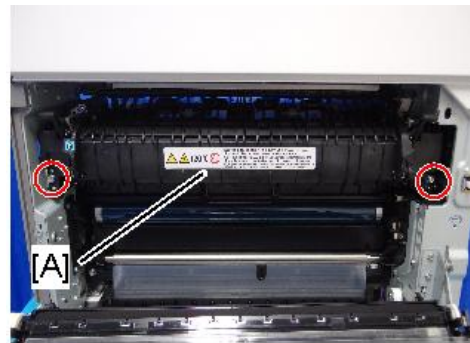

x2



d205m4095

7. Fusing unit [A]

Replacement and Adjustment



## Fusing Unit

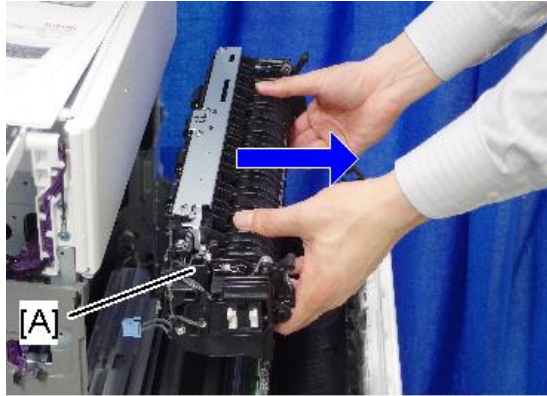

d205m4097

### Notes on Installing the Fusing Unit

1. Enter the SP mode.
2. Do SP-7-622-115 to clear the counter.

### 3.13.3 FUSING THERMISTOR

1. Fusing unit (page 3-84)
2. Plate [A]

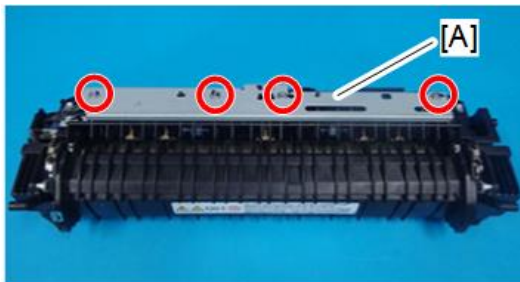

 x4

d205z5028

3. Connector

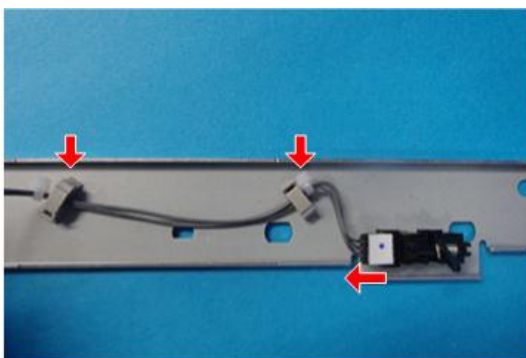

 x2,  x1

d205z5029

4. Connector cover [A]

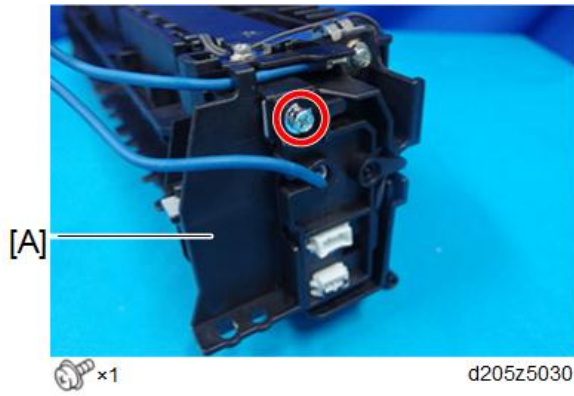

5. Fusing thermistor [A]

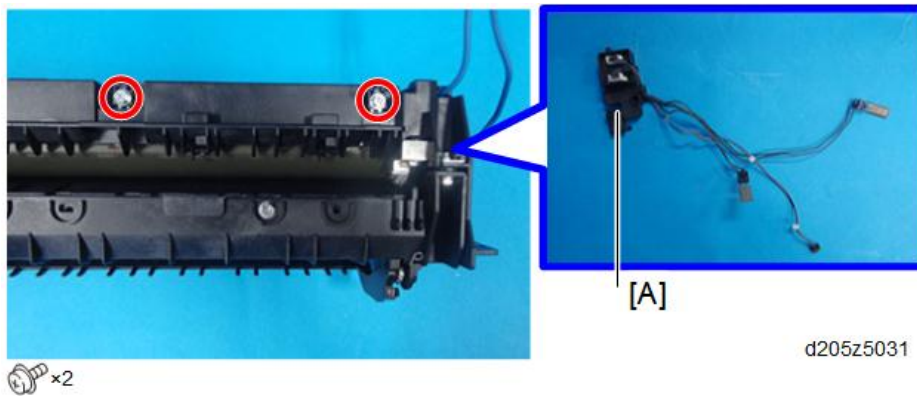

Replacement  
and Adjustment

3.13.4 FUSING LAMP

1. Fusing thermistor (page 3-86)
2. Remove the screws attached to the both side of the fusing unit, and harness guide.

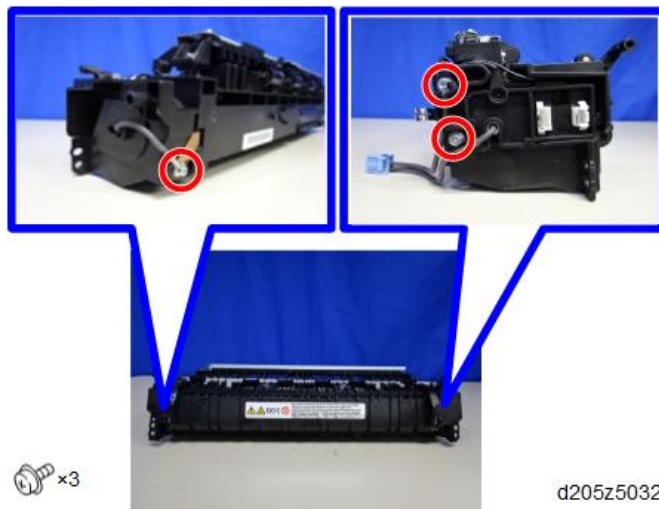

3. Dismantle the fusing unit [A] and pressure roller unit [B].

## Fusing Unit

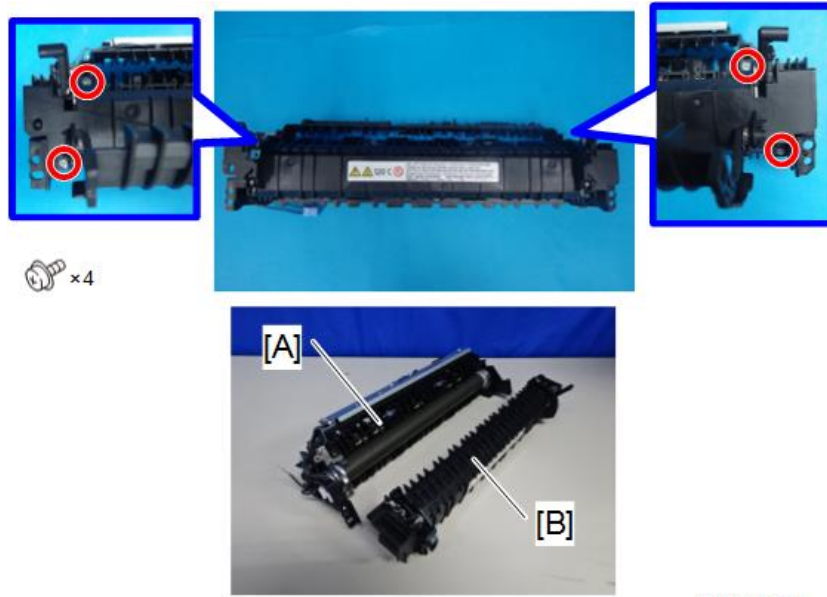

d205z5034

### 4. Fusing lamp [A]



d205z5033

### 3.13.5 PRESSURE ROLLER AND BUSHINGS

1. Fusing unit (page 3-84)
2. Dismantle the fusing unit [A] and pressure roller unit [B].

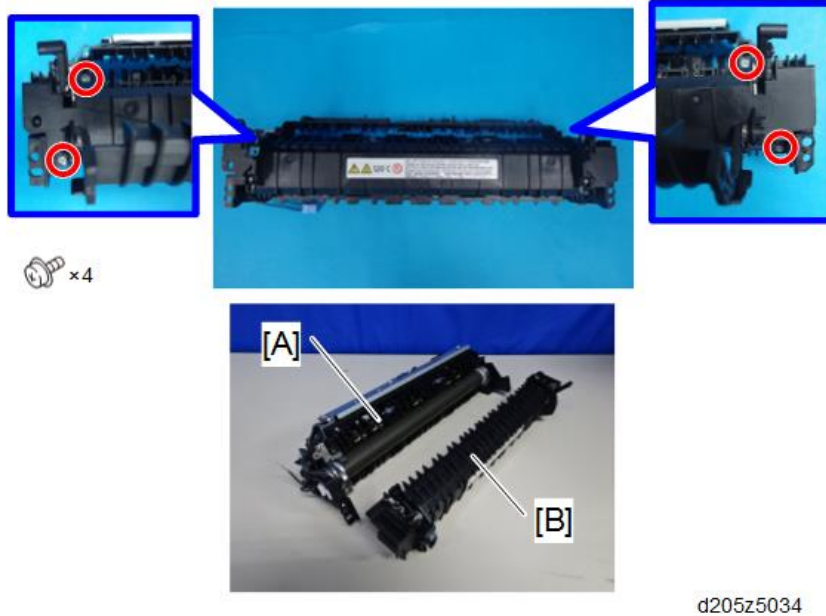

3. Spring hook [A]



4. Bushings [A]



5. Pressure roller [A]

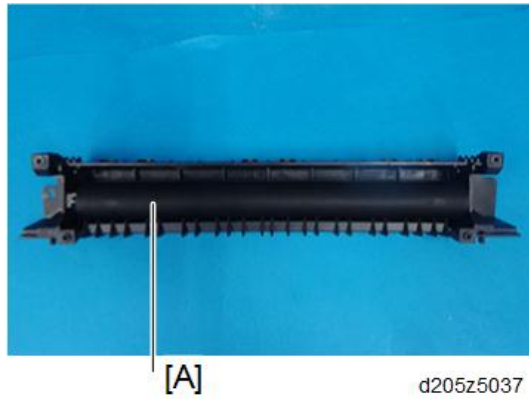

### ***Notes on Installing the Pressure Roller***

Do the nip width adjustment after replacing the pressure roller.

**1. Place an OHP sheet on the by-pass feed table.**

The size of the OHP sheet must be A4/LEF or LT/LEF. Any other sizes may cause a paper jam.

**2. Enter SP mode, and run SP1-152-001 (Fusing Nip Band Check).**

**3. Enter [1] by using the numeric keypad and press [OK].**

**4. Press [Start]. Switch to the copy mode temporarily.**

Make sure that the bypass tray is selected as the feed tray.

**5. Press [Start].**

The machine feeds the OHP sheet to the fusing unit after 5 minutes as a default, and stops for 20 seconds after the paper exit sensor turns ON. After that, the OHP will be ejected to the paper exit tray.

**6. Press [Reset] to return to the SP mode.**

**7. Enter [0] by using the numeric keypad and press [OK].**

**8. Press [Return] a few times and exit SP mode.**

**9. Check that the nip band (the opaque stripe) across the ejected OHP sheet is symmetrical, with both ends slightly thicker than the center.**

### 3.13.6 HOT ROLLER

1. Fusing lamp (page 3-87)
2. Pressure roller (page 3-89)
3. Ground plate [A], and hot roller [B]

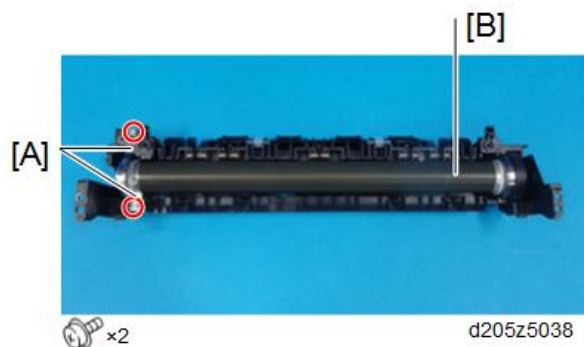

#### *Applying the grease*

Before installing the hot roller, apply the grease (Silicon Grease G-501) as shown below.

1. Hot roller (page 3-91)
2. Bearings [A] and gear [B]

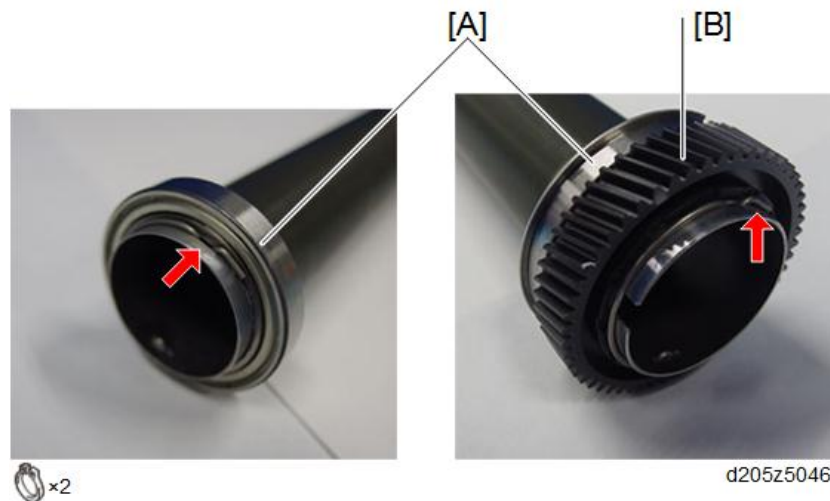

3. Attach the bearings to the ends of the hot roller, and apply the grease all around the roller.  
Do not fix the bearings at this time.
4. To apply the grease evenly, slide the bearings right and left from 5 to 10 times within the area shown by the blue arrows below.



## Fusing Unit

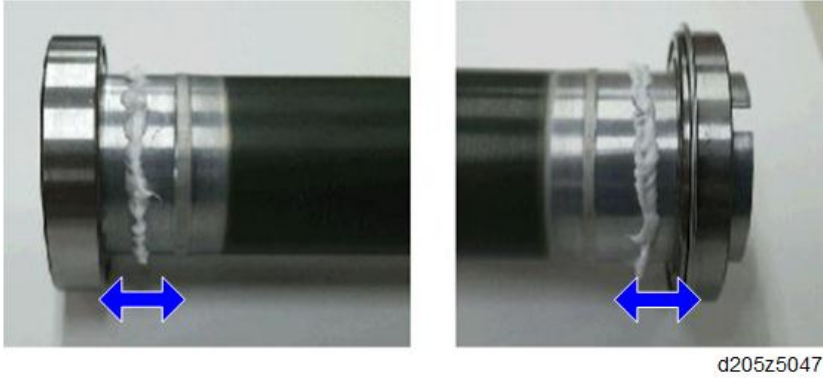

### ⬇ Note

- It is acceptable that a little grease spills out when installing the bearing.

5. Fix the bearing to the end of the roller, where the gear is not to be attached, with a C-ring.
6. Apply the grease to the other end of the roller, where the gear is to be attached, as shown below.

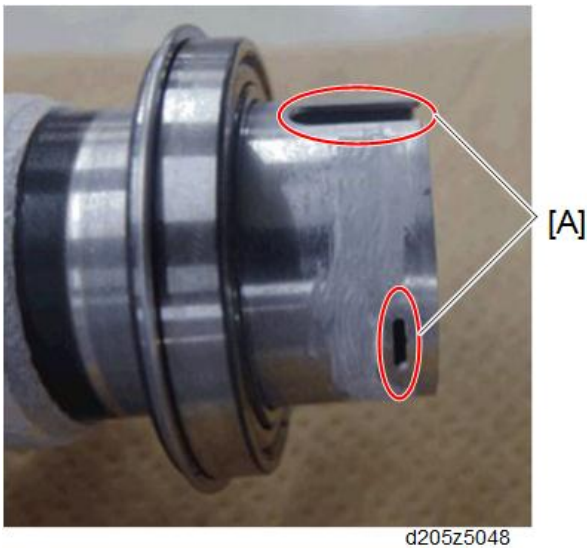

### ⚠ CAUTION

- Do not apply the grease within 1 mm of the areas [A].

7. Attach the other bearing and gear with a C-ring.

### 3.13.7 HOT ROLLER STRIPPER PAWLS

1. Hot roller (page 3-91)
2. Hot roller stripper pawls [A]

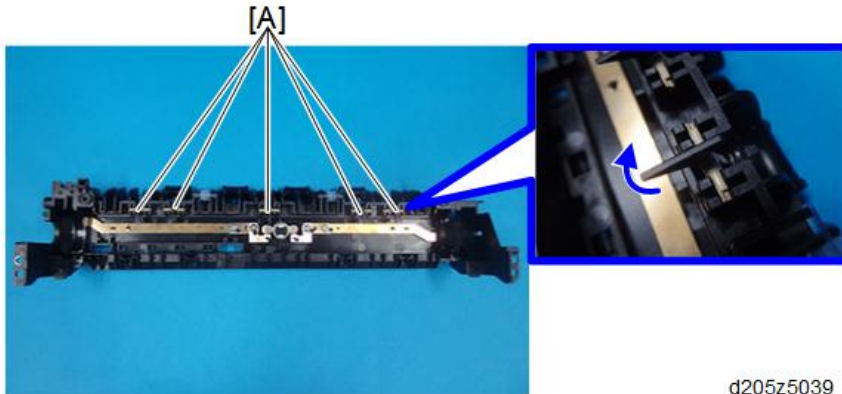

d205z5039

Replacement  
and Adjustment

### 3.13.8 THERMOSTAT

1. Hot roller (page 3-91)
2. Thermostat [A]

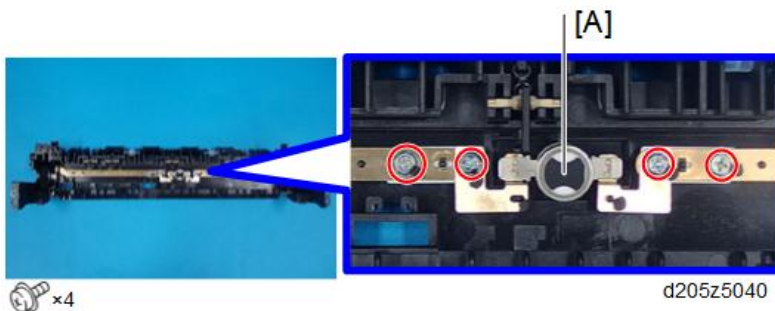

d205z5040

## 3.14 DUPLEX, PAPER EXIT

### 3.14.1 DUPLEX UNIT (RIGHT COVER)

1. Open the right cover [A] and remove the clip ring and E-ring.

**Note**

- Do not open the right cover [A] more than 90°.

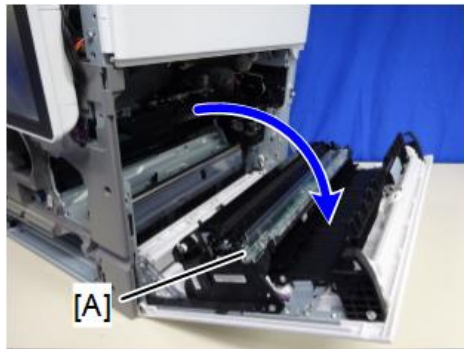

d205z4183

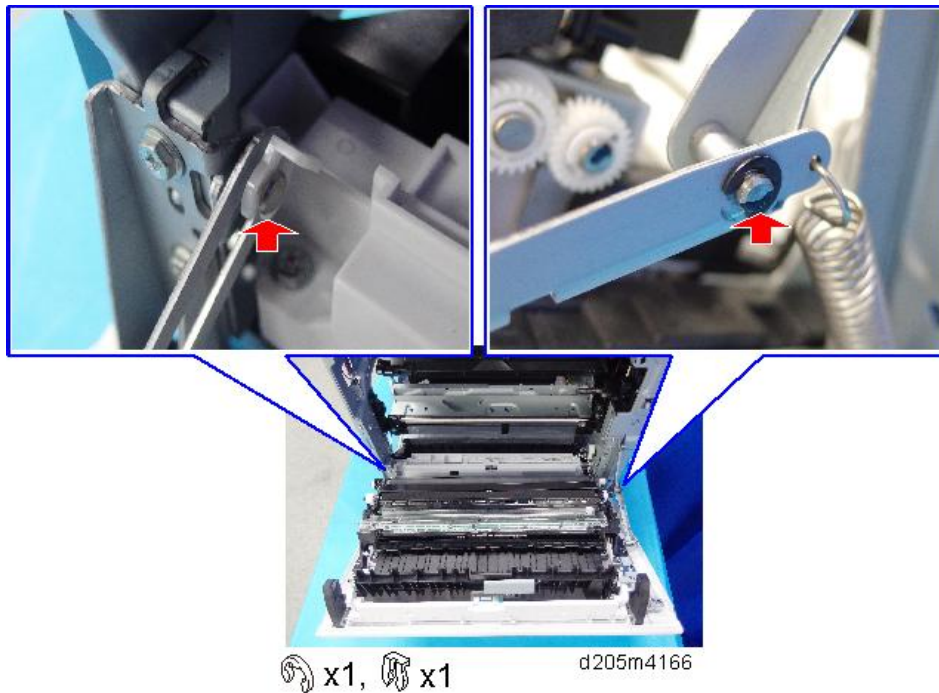

2. Open the harness cover [A] and disconnect the connector.

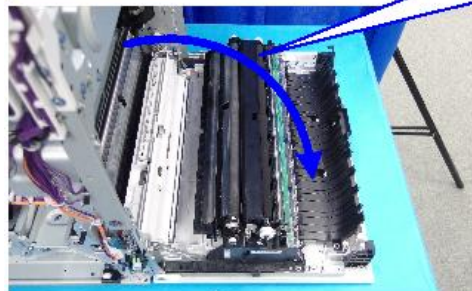
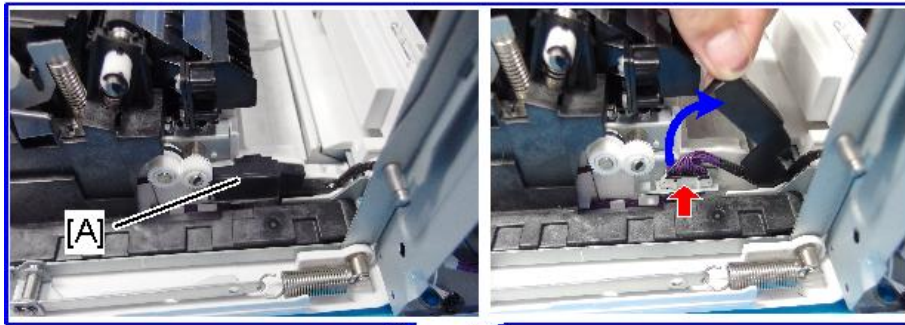

x1

d205m4167

3. Right cover [A]



x6

d205m4168

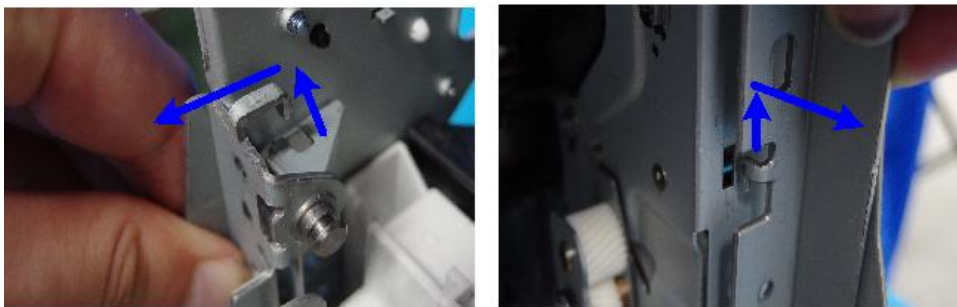

d205m4169



### 3.14.2 PAPER EXIT ROLLER

1. Paper exit clutch, Reverse exit clutch (page 3-97)
2. Gears [A] [B], timing belt [C]

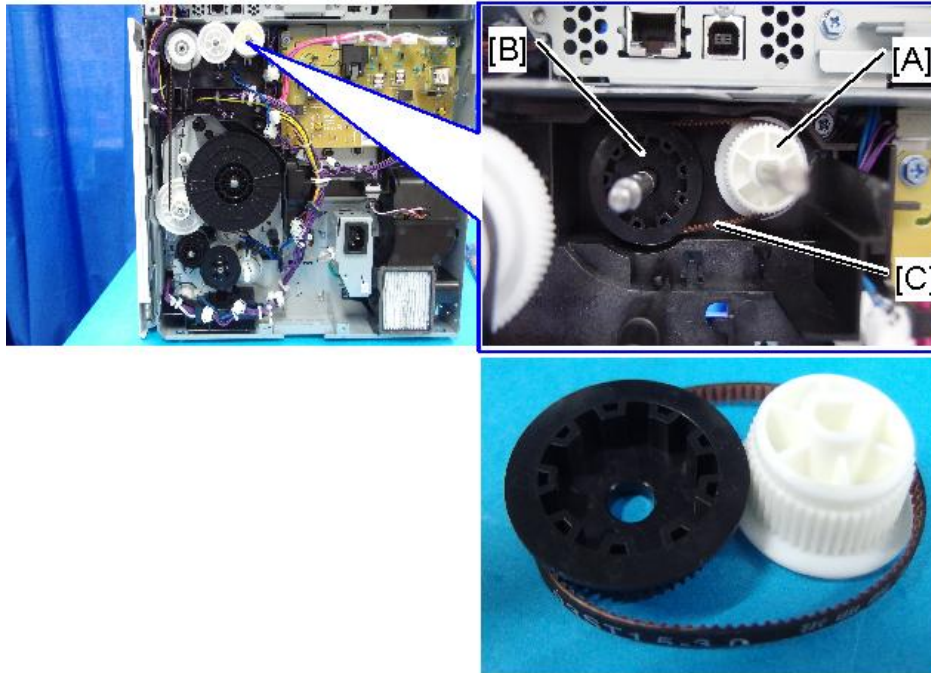

d205m4194

3. Remove the bearings at the front and rear sides of the machine, and then remove the paper exit roller [A].

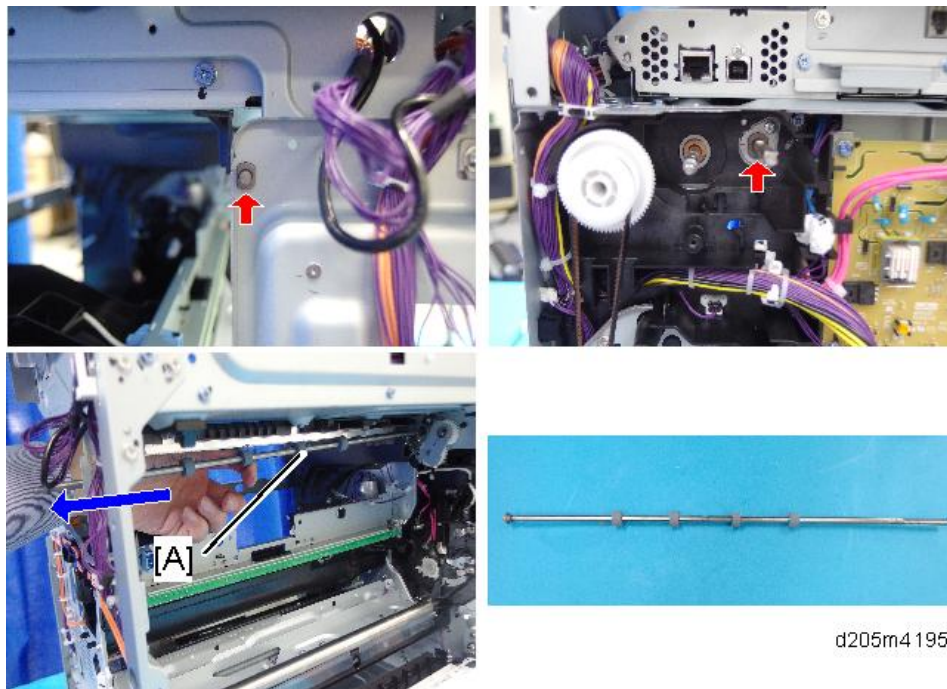

d205m4195

### 3.14.3 PAPER EXIT REVERSE SENSOR

1. Fusing unit (page 3-84)
2. Bracket [A]

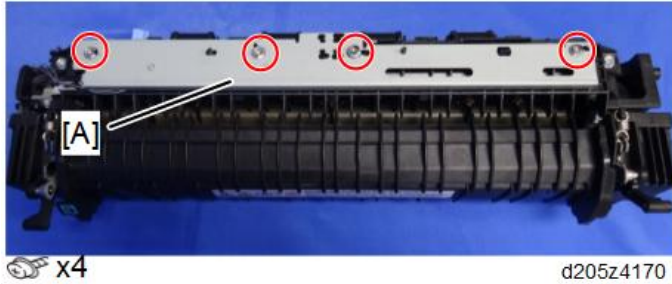

3. Paper exit reverse sensor [A].

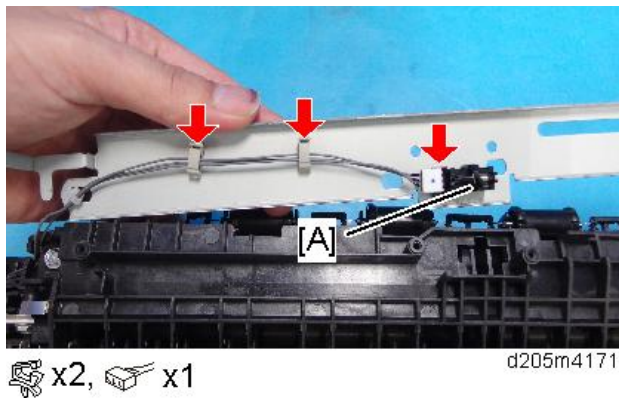

### 3.14.4 PAPER EXIT CLUTCH, REVERSE EXIT CLUTCH

1. Rear cover (page 3-5)
2. Gear bracket [A]

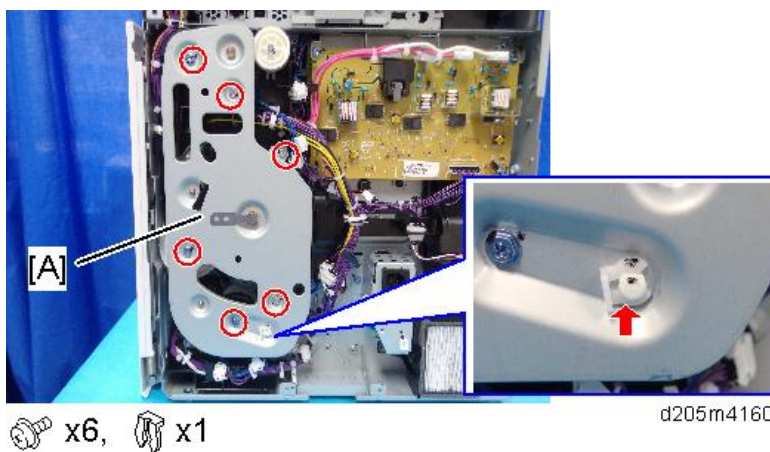

3. Gears [A], [B]

Gear [B] has a shaft pin [C]. Be careful not to lose it when you remove these parts.



## Duplex, Paper Exit

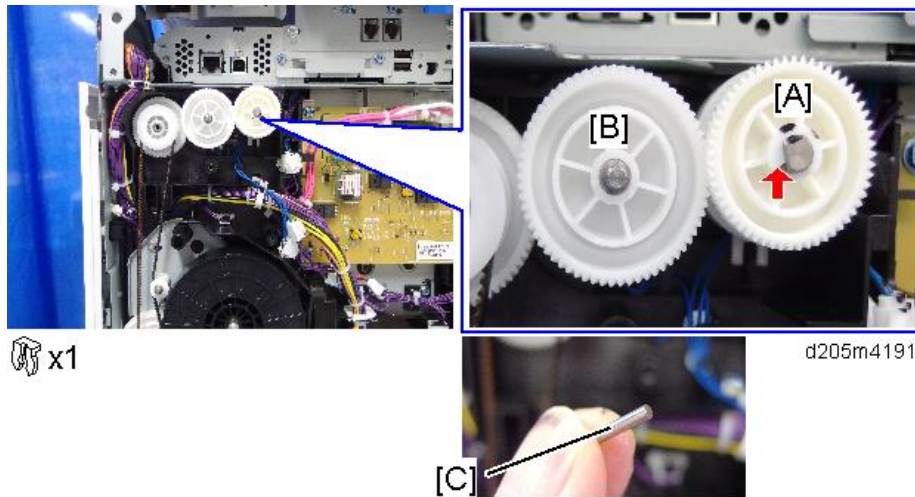

### 4. Paper exit clutch [A], and reverse exit clutch [B]

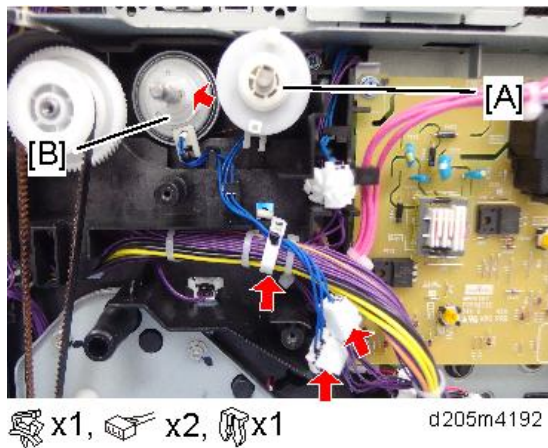

### 5. Pull out the gear [A] slightly and remove the reverse exit clutch [B].

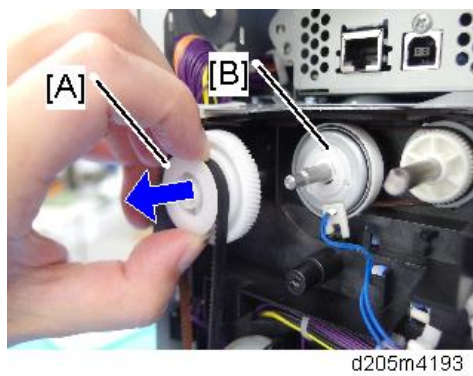

### 3.14.5 DUPLEX ENTRANCE SENSOR

1. Open the right cover and remove the cover [A].

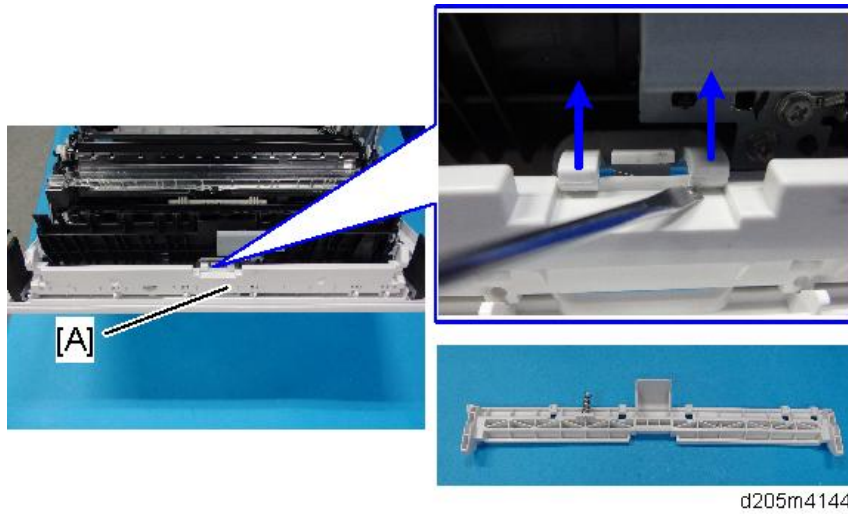

2. Bracket [A] followed by duplex entrance sensor [B].

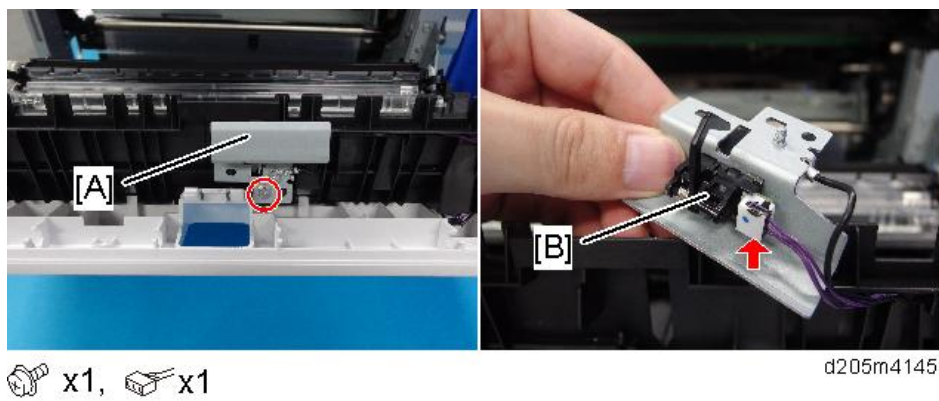

### 3.14.6 DUPLEX EXIT SENSOR

1. Open the right cover and remove the connector cover [A].

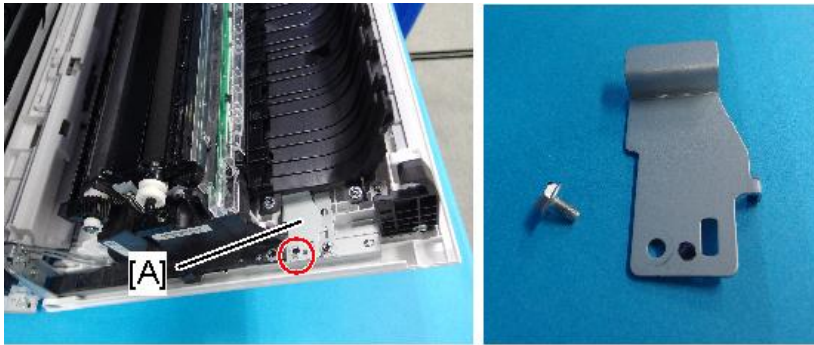

 x1

d205m4140

2. Connectors

Upper: Duplex exit sensor

Lower: PCL/ID sensor

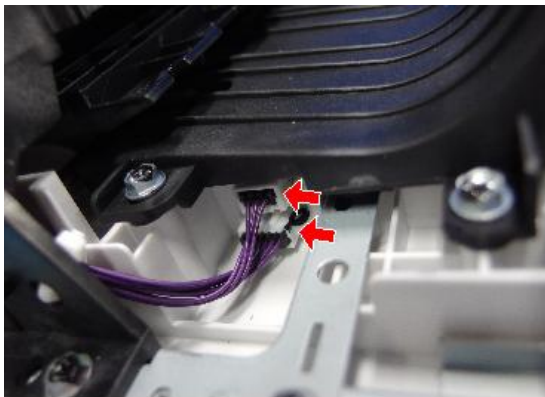

 x2

d205m4141

3. Lift the frame [A] of the duplex unit.

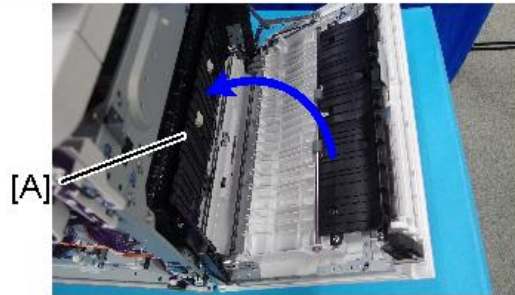

 x2

d205m4142

Replacement  
and Adjustment

4. Clamp

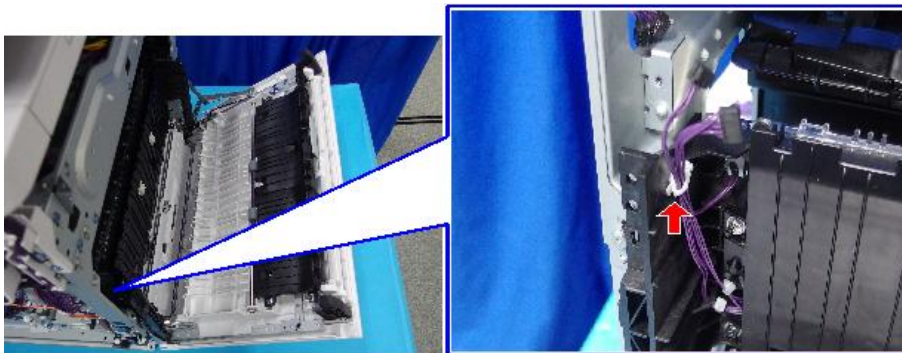

 x1

d205m4146

5. Duplex guide plate [A]

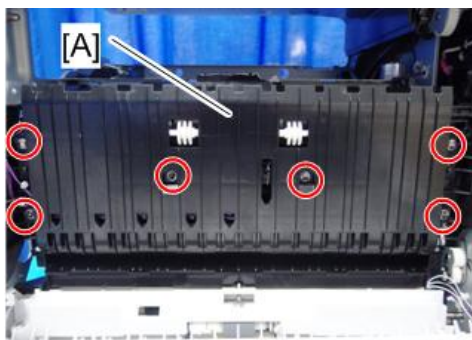



 x6

d205m4147

6. Duplex exit sensor [A]

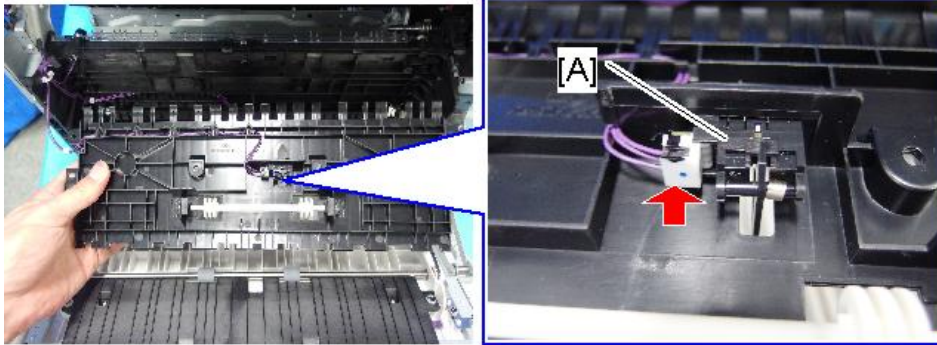



 x1

d205m4148

### 3.14.7 DUPLEX ROLLERS

#### *Duplex Drive Roller*

1. Open the right cover and remove the connector cover [A].

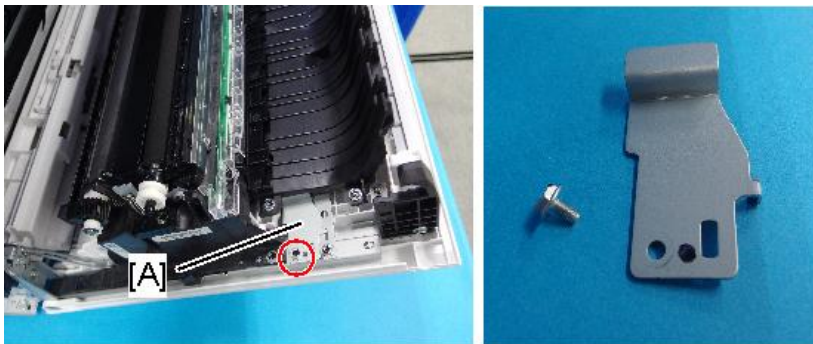

 x1

d205m4140

2. **Connectors**

Upper: Duplex exit sensor

Lower: PCL/ID sensor



 x2

d205m4141

3. Lift the frame [A] of the duplex unit.

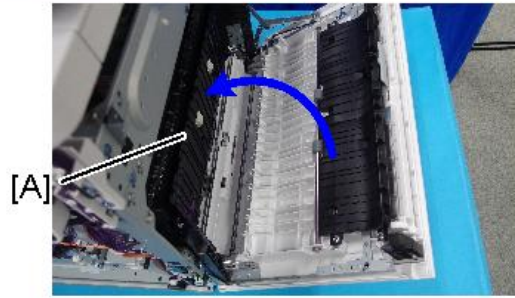

x2

d205m4142

4. Clip rings of the duplex drive roller

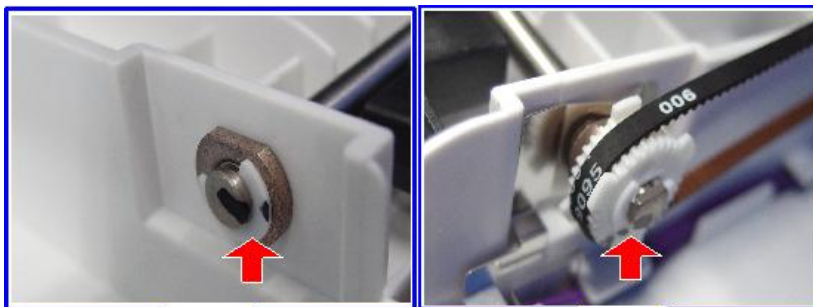

d205m4156



x2

5. Timing belt [A], bearings [B], and gear [C]

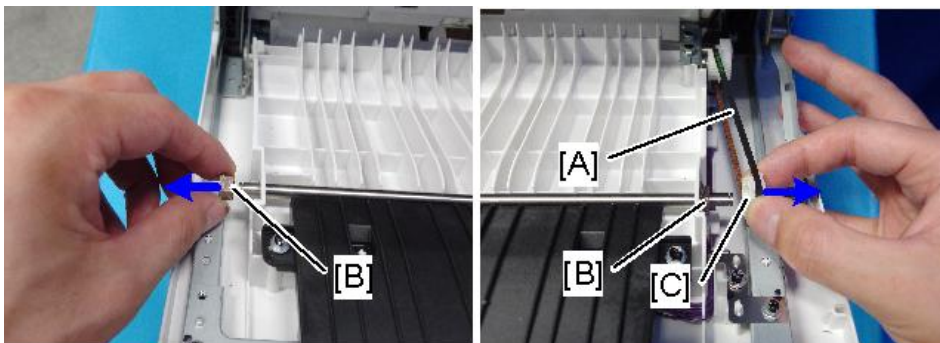

d205m4157

6. Duplex drive roller [A]



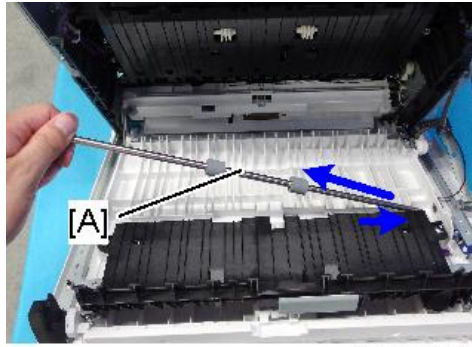

d205m4158

### Duplex Driven Roller

1. Open the right cover and remove the connector cover [A].

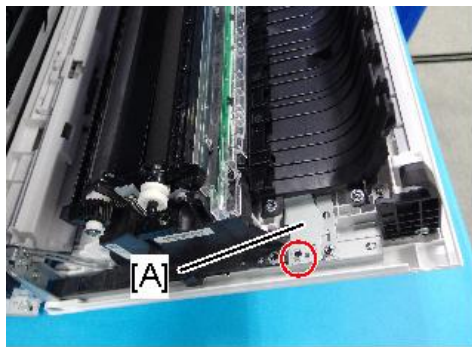

d205m4140

 x1

2. **Connectors**

Upper: Duplex exit sensor

Lower: PCL/ID sensor

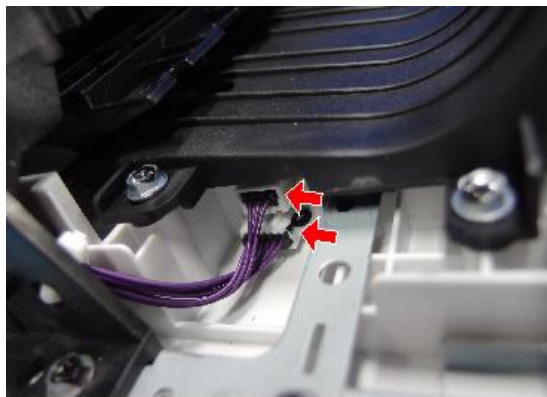

d205m4141

 x2

3. Lift the frame [A] of the duplex unit

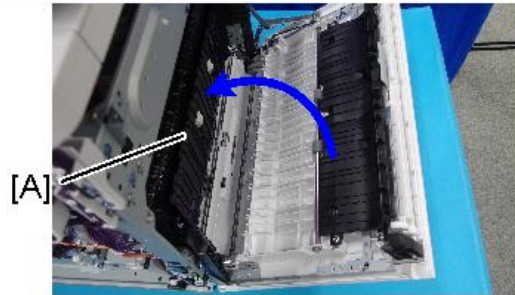

 x2

d205m4142

Replacement  
and Adjustment

4. Clamp

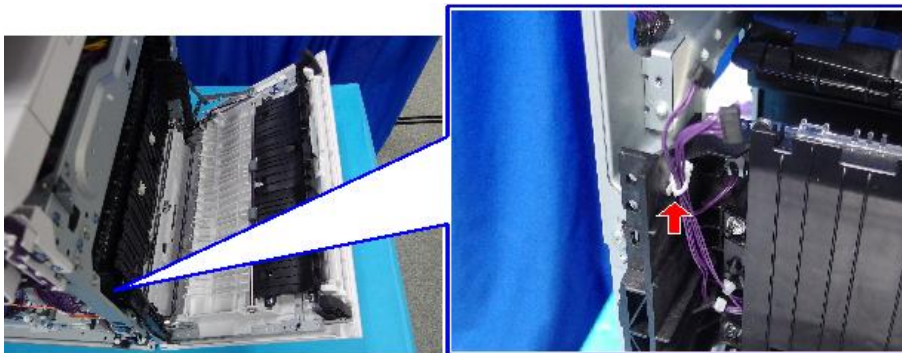

 x1

d205m4146

5. Duplex guide plate [A]

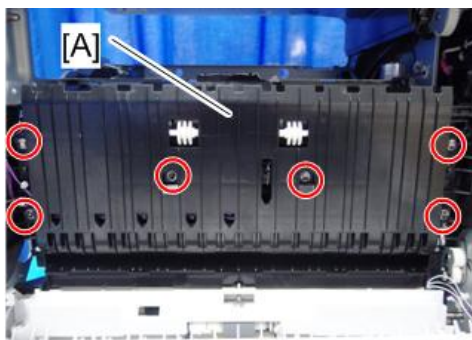

 x6

d205m4147

6. Duplex driven roller [A]

## Duplex, Paper Exit

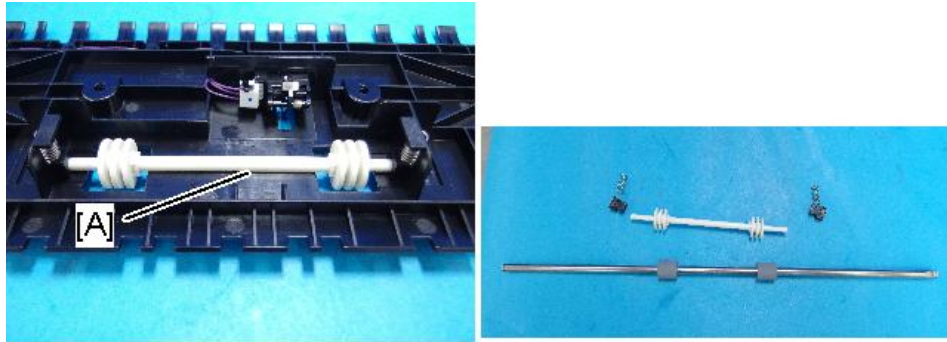

d205m4159

### ***How to Clean the Duplex Driven Roller and the Duplex Drive Roller***

Wipe the duplex driven roller [A] and the duplex drive roller [B] with a damp cloth.

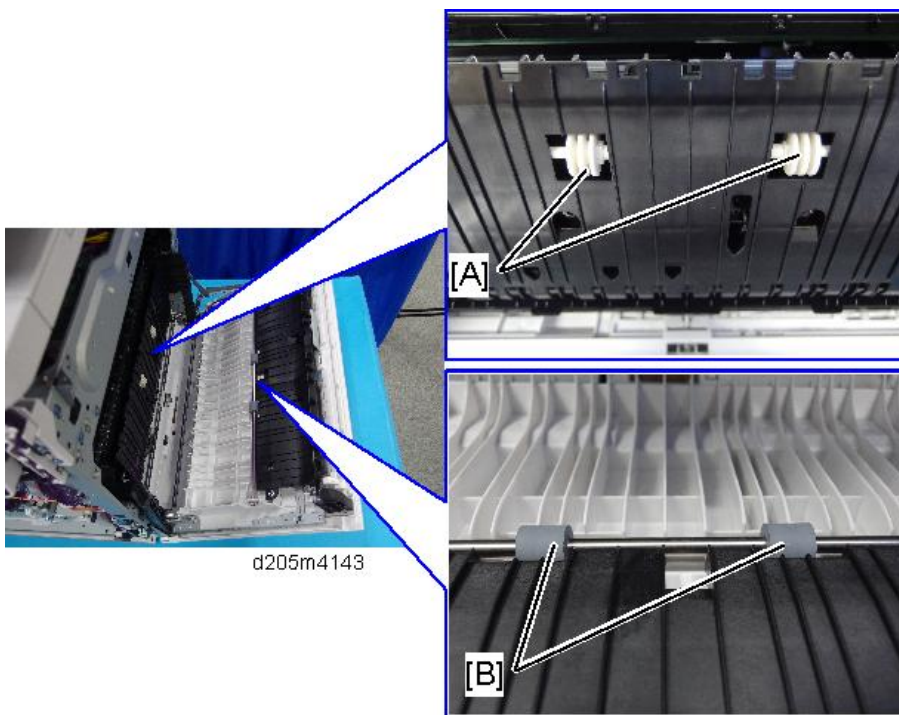

d205m4143



### 3.14.8 DUPLEX REVERSE CLUTCH

1. Rear cover (page 3-5)
2. Gear bracket [A]

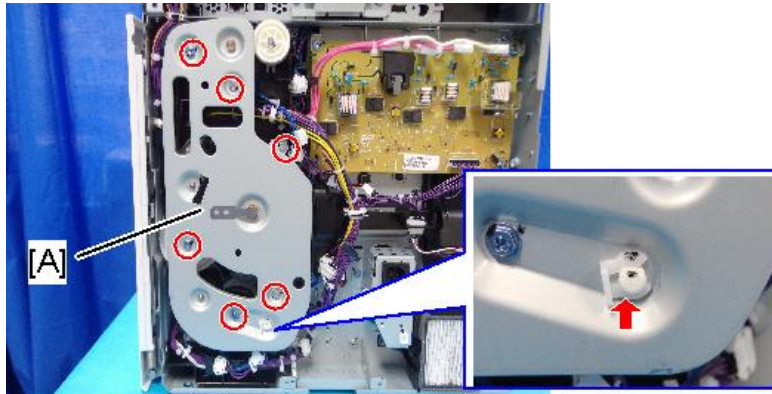

⚙️ x6, 🔩 x1

d205m4160

Replacement and Adjustment

3. Gear [A] and gear [B]

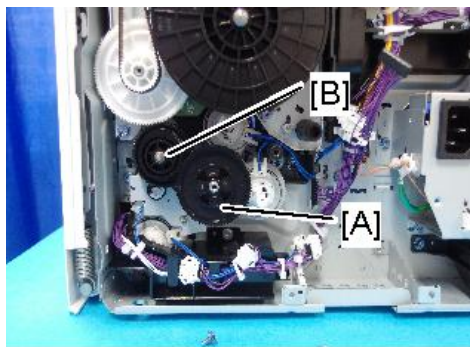

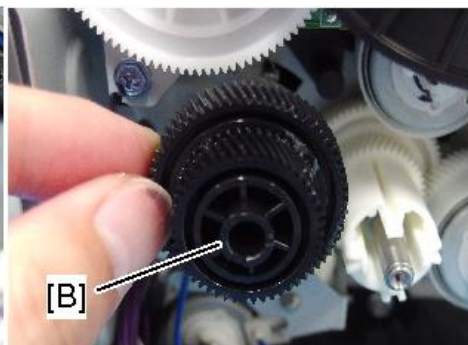
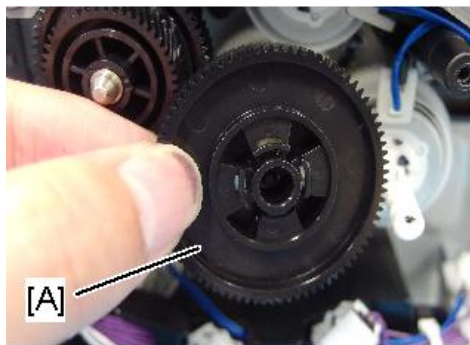

d205m4161

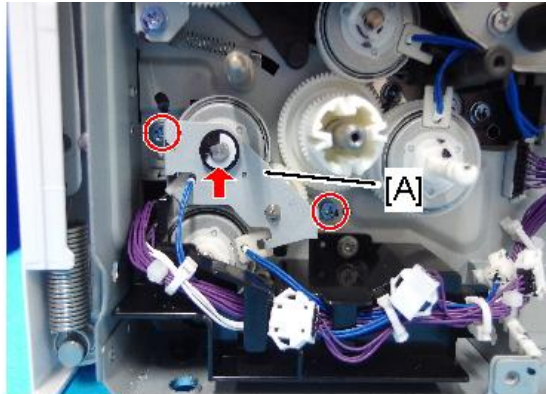

d205m4164

4. Bracket [A]



 x2,  x1

d205m4162

### 5. Duplex reverse clutch [A]

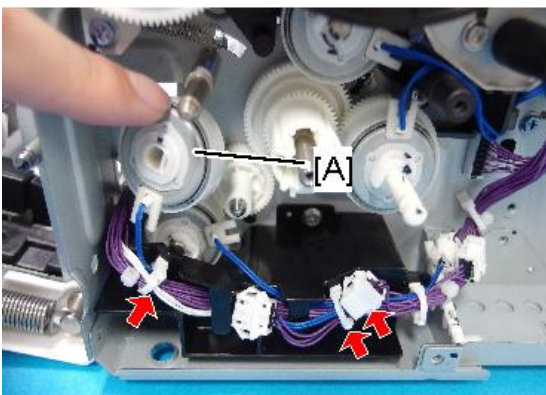

 x2,  x1

d205m4163

### ***Notes on Installing the Duplex Reverse Clutch***

The duplex reverse clutch [A] and the bypass clutch [B] are fixed by a bracket. Position the clutches as shown in the following picture.

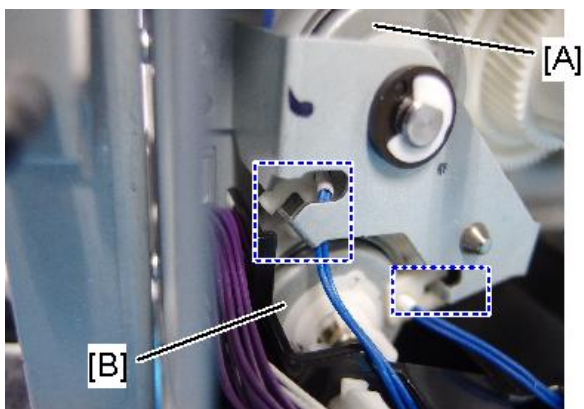

d205m4165

### 3.14.9 PAPER EXIT INDICATOR

1. Left lower cover (page 3-9)
2. Paper exit tray (page 3-13)
3. Cover [A]

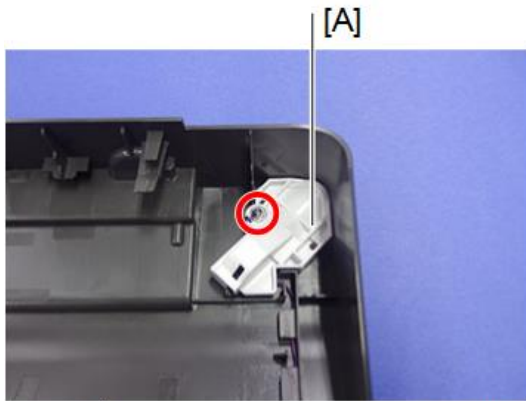

🔑 x1

d205z5026

4. Paper exit indicator [A]

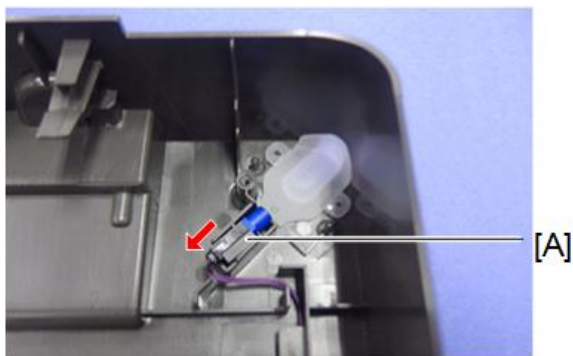

d205z5027



## 3.15 BYPASS

### 3.15.1 BYPASS CLUTCH

The bypass clutch is located as shown in the picture.



d205m4118

1. Rear cover (page 3-5)
2. Harness holder [A]

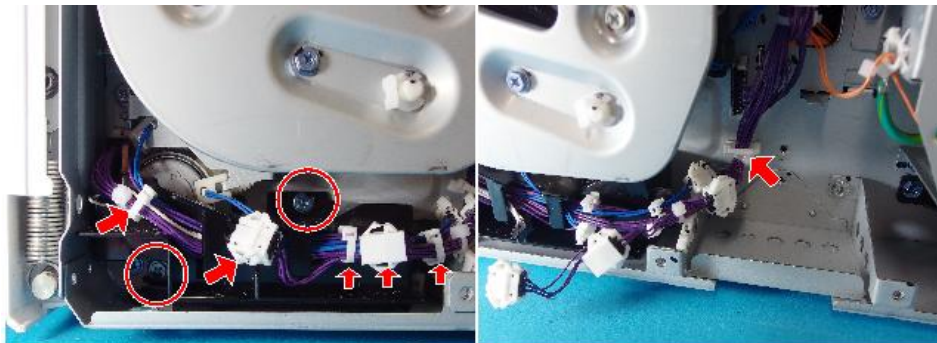

 x2,  x2,  x4

d205m4119

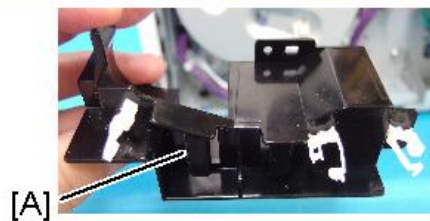

3. Bypass clutch [A]

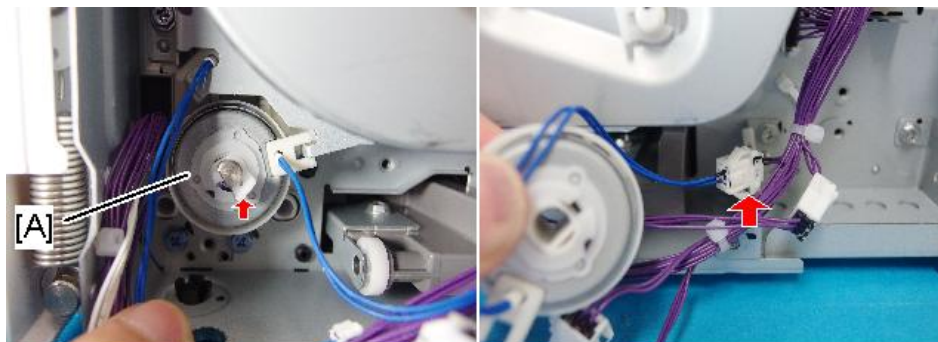

 x1,  x1

d205m4120

### 3.15.2 BYPASS UNIT

1. Pull out the paper feed tray.
2. Screw of the front inner cover [A]

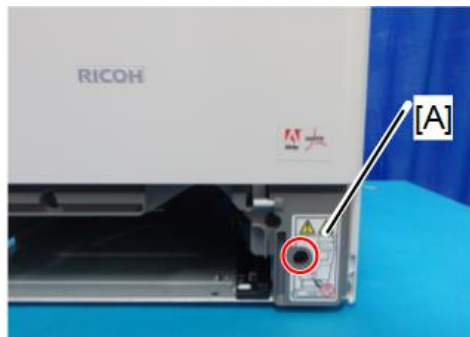



 x1

d205m4121

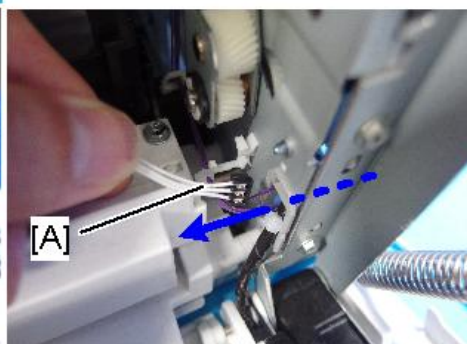
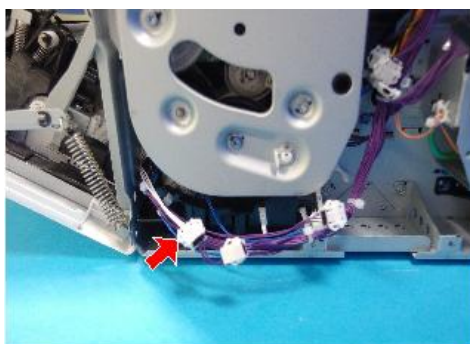
3. Release the harness at the left lower area of the rear and pull the harness of the bypass paper end sensor [A] to the inside.



 x1,  x1

d205m4122

4. Hold the bypass unit [A] with both hands, and slide it towards the rear of the machine. Then remove it upwards at an angle towards the front side of the machine.

## Bypass

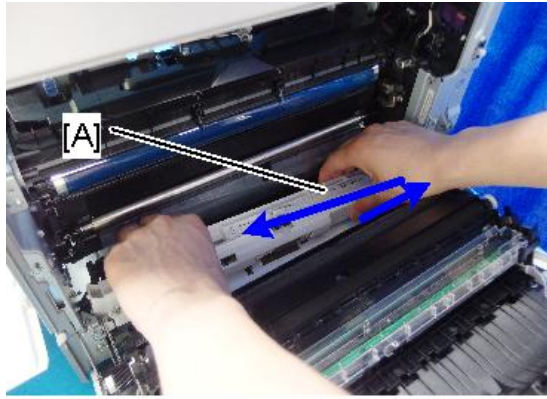



d205m4123

### 3.15.3 BYPASS PAPER END SENSOR

1. Bypass unit (page 3-111)
2. Cover





 x2,  x1

d205m4124

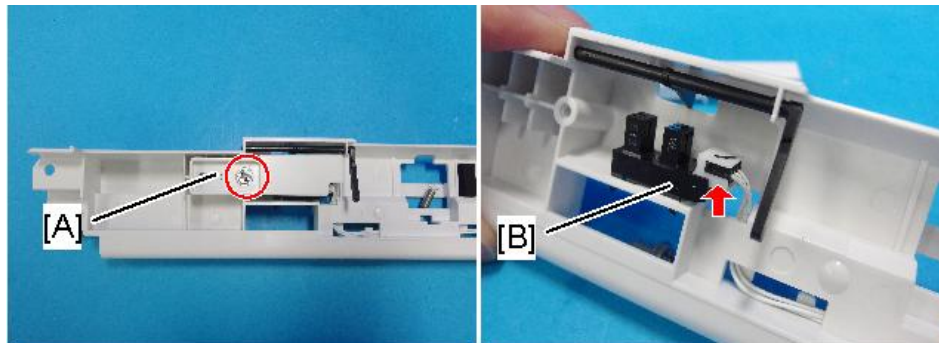
3. Bracket [A], and Bypass paper end sensor [B]



 x1,  x1

d205m4125



### 3.15.4 BYPASS PAPER FEED ROLLER, BYPASS SEPARATION ROLLER

1. Bypass unit (page 3-111)
2. Bypass paper feed unit [A]

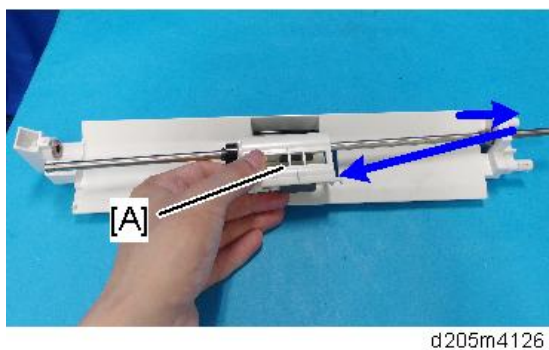

3. Bypass paper feed roller [A]  
Pull it out while turning the shaft.

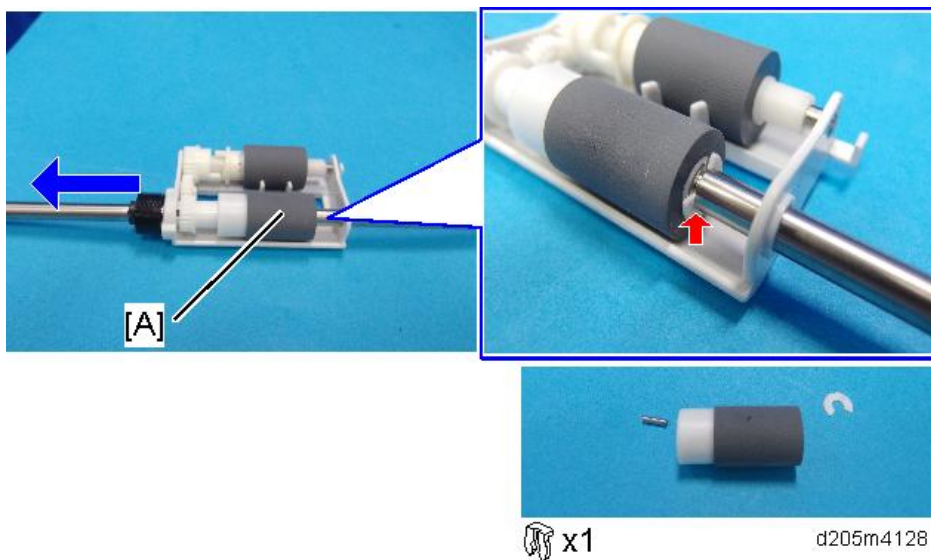

## Bypass

### 4. Bypass separation roller [A]

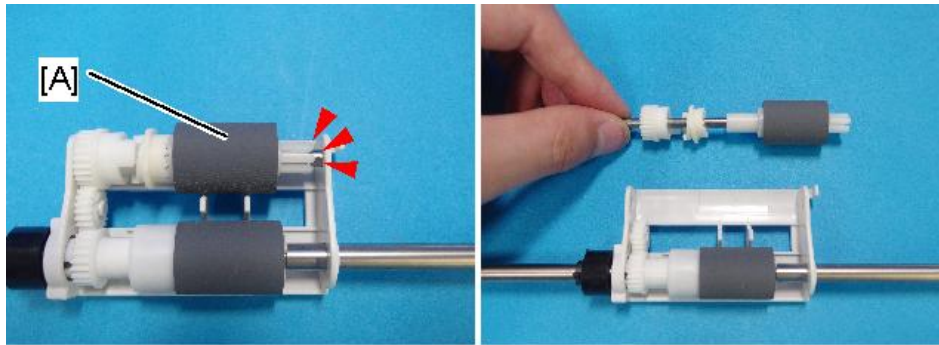

d205m4130

### ***Notes on Installing the Bypass Separation Roller***

Make sure that the pin [A] is set in the guide of the paper feed unit.

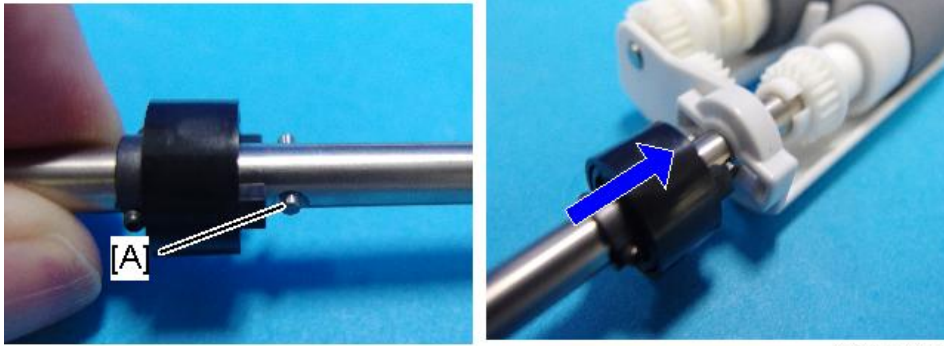

d205m4129

## 3.16 ELECTRICAL COMPONENTS, OTHER ITEMS

### 3.16.1 CONTROLLER BOX

**Note**

- To remove only the controller box, it is not necessary to remove the scanner unit.

- Rear cover (page 3-5)
- Controller box [A]

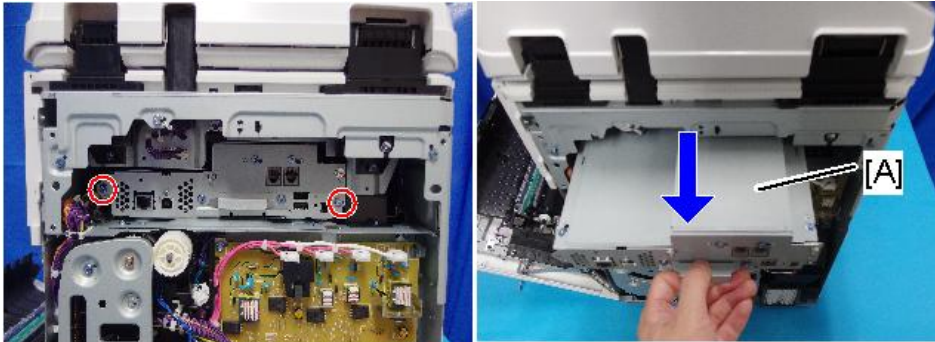

 x2

d205m4107

To remove it, hold the slot cover for the SD Card.

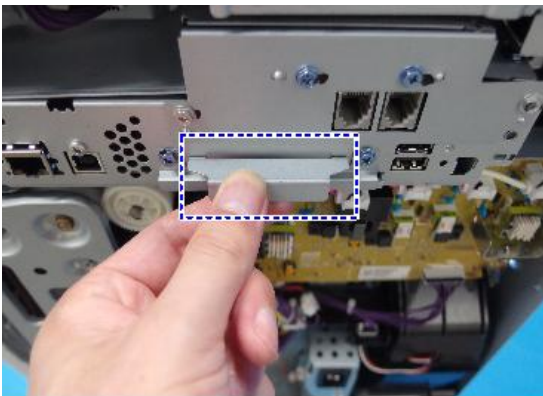

d205m4108

**Note**

- If the scanner unit has been removed, do not push the controller box [A] with your fingers. Otherwise the connector pins may be damaged. Push the side of the box slowly and remove it.

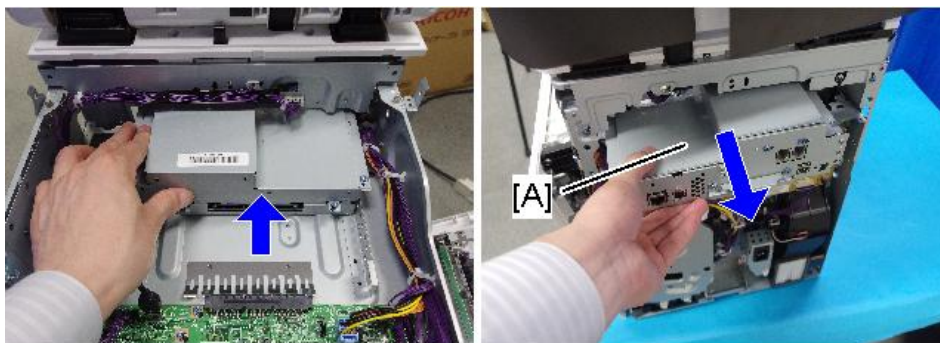

d205m4111



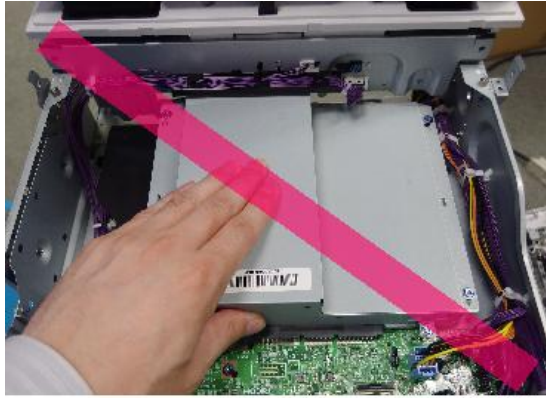

d205m4112

### ***Notes on Installing the Controller Box***

After installing the controller box part of the way, push it in gently with your fingers. Then connect it securely to the connector [A] on the BiCU. (This picture shows the machine with the scanner unit removed. You do not have to remove the scanner unit to do this procedure.)

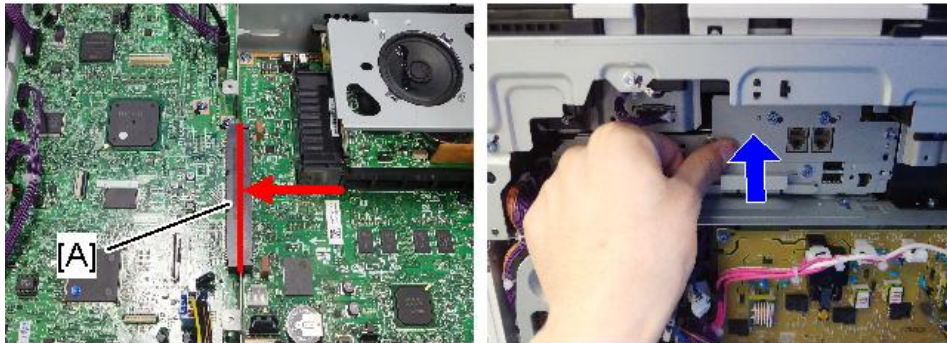

d205m4113

### 3.16.2 CONTROLLER BOARD

#### ★ Important

- If you remove the controller board right after disconnecting the power cord, the machine will be damaged.

1. Controller box (page 3-115)
2. Upper cover [A]

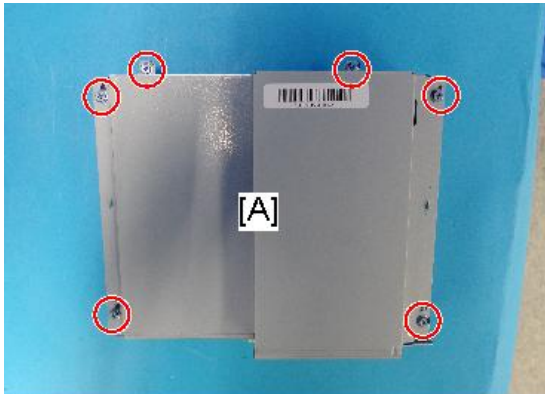

x6

d205m4109

3. Controller board [A]

#### ↓ Note

- When replacing the controller board, remove the NVRAM [B] and then install it on the new controller board

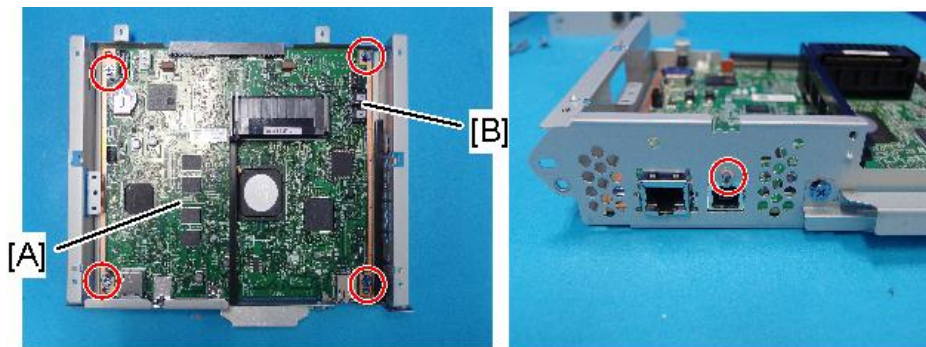

x5

d205m4110

#### Notes on Replacing the Controller Board

- Install the NVRAM [A] from the old controller board on the new controller board before replacing. The NVRAM contains the SP settings.
- Do not touch DIP-SW [B]. Do not use in the field.

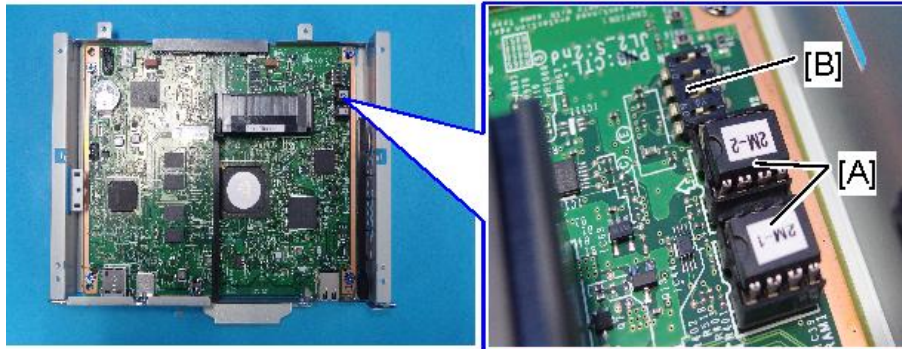

d205m411b

### 3.16.3 BICU (BASE-ENGINE IMAGE CONTROL UNIT)

1. Scanner unit (page 3-37)
2. BiCU [A]

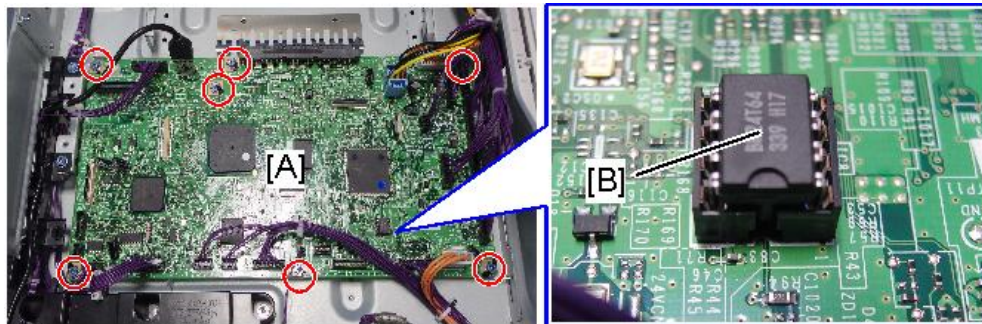

w\_d205m4114

 x7,  x All

#### Note

- When replacing the BiCU, remove the NVRAM [B] from the old BiCU and install it on the new BiCU.

### 3.16.4 NVRAM

#### ***NVRAM on the Controller Board***

#### **⚠ CAUTION**

- SC195 (Machine serial number error) will be displayed if the NVRAM is not attached.
  - If you mounted the NVRAM in the wrong direction, each component needs to be replaced because a short circuit was caused in the controller board and the NVRAM.
  - Installing a new NVRAM initializes SPs and issues an SC. Reset the SC with the procedure below.
1. **Make sure that you have the SMC report (factory settings). This report comes with the machine.**
  2. **Output the SMC log using one of the following:**  
 To print SMC log data, execute SP5-990-001.  
 To save SMC log data to an SD card, execute SP5-992-001.
  3. **Turn OFF the main power.**
  4. **Insert a blank SD card in the SD slot #2, and then turn ON the main power.**
  5. **Upload the NVRAM data from the controller board using SP5-824-001.**
  6. **Make sure the customer has a backup of their address book data. If not, obtain the backup by referring to SP5-846-051.**

#### **★ Important**

- The address data stored in the machine will be discarded later during this procedure. So be sure to obtain a backup of the customer's address book data.
  - Note that the counters for the user will be reset when doing the backup/restore of the address book data.
  - If they have a backup of the address book data, use their own backup data for restoring. This is because there is a risk that the data cannot be backed up properly depending on the NVRAM condition.
7. **Do the following if the machine has the fax unit. If not, skip this step:**
    1. Print the Box List with the User Tools/Counter.
      - [User Tools/Counter] - [Facsimile Features] - [General Settings] - [Box Setting: Print List]
    2. Print the Special Sender List by pressing these buttons in the following order.
      - [User Tools/Counter] - [Facsimile Features] - [Reception Settings] - [Program Special Sender: Print List]
    3. Write down the following fax settings.
      - [Receiver] in [User Tools/Counter] - [Facsimile Features] - [Reception Settings] - [Reception File Settings] - [Forwarding].
      - [Notify Destination] in [User Tools/Counter] - [Facsimile Features] - [Reception Settings] - [Reception File Settings] - [Store].

- [Specify User] in [User Tools/Counter] - [Facsimile Features] - [Reception Settings] - [Stored Reception File User Setting].
- [Notify Destination] in [User Tools/Counter] - [Facsimile Features] - [Reception Settings] - [Folder Transfer Result Report].
- Specified folder in [User Tools/Counter] - [Facsimile Features] - [Send Settings] - [Backup File TX Setting].
- [Receiver] in [User Tools/Counter] - [Facsimile Features] - [Reception Settings] - [Reception File Settings] - [Output Mode Switch Timer].
- [Store: Notify Destination] in [User Tools/Counter] - [Facsimile Features] - [Reception Settings] - [Output Mode Switch Timer].
- All the destination information shown on the display.

 **Note**

- In the fax settings, address book data is stored with entry IDs, which the system internally assigns to each data. The entry IDs may be changed due to re-assigning in backup/restore operations.
4. Make sure that there is no transmission standby file. If any standby file exists, ask the customer to delete it or complete the transmission.

**8. Turn OFF the main power and unplug the power supply cord.**

**9. Press the main power switch again to discharge the residual charge.**

**10. Replace the NVRAM with a new one.**

**11. Turn ON the main power.**

 **Important**

- **SC673 appears at start-up, but this is normal behavior. This is because the controller and the smart operation panel cannot communicate with each other due to changing the SP settings for the operation panel.**

1. Change the SP settings for the operation panel.
  - SP5-748-101: (OpePanel Setting: Op Type Action Setting): Change bit 0 from “0” to “1”.
  - SP5-748-201: (OpePanel Setting: Cheetah Panel Connect Setting): Change the value from “0” to “1”.

**12. Turn OFF then ON the main power with the SD card where the NVRAM data has been uploaded in SD slot 2.**

 **Important**

- **SC992 appears at start-up, but this is normal behavior. This is because information written to the NV-RAM and on the hard disk do not match due to replacement of the NV-RAM. Go to Step 13.**

**13. Download the NVRAM data stored in the SD card to the brand-new NV-RAM using SP5-825-001.**



**Note**

- The download will take a couple of minutes.

14. Turn OFF the main power and remove the SD card from SD slot 2.

15. Turn ON the main power.

16. Restore the original settings of the following SPs, referring to the SMC data obtained in step 2.

**Note**

- SP5-825-001 does not download the following SP data to the new NVRAM. So you must set them manually.

a. SP5-985-001 (Device Setting: On Board NIC)

b. SP5-985-002 (Device Setting: On Board USB)

17. If the security functions (HDD Encryption and HDD Data Overwrite Security) were applied, set the functions again.

18. Ask the customer to restore their address book. Or restore the address book data using SP5-846-052, and ask the customer to ensure the address book data has been restored properly.

**Important**

- If you have obtained the backup of the customer's address book data, delete the backup immediately after the NVRAM replacement to avoid accidentally taking out the customer's data.

19. Output the SMC log using one of the following methods:

To print SMC log data, execute SP5-990-001.

To save SMC log data to an SD card, execute SP5-992-001

**Note**

- Check that the counters are reset.

20. Make sure that the list output in step 7-1 through step 7-3 matches the destination information in step 7-4. If not, set it to the setting before replacement.

21. Execute the process control manually (SP2-011-001).

**Important**

- Try all the items below if NVRAM upload (SP5-824-001) or download (SP5-825-001) cannot be done.
  - Check the SP values that changed on the SMC you printed out in step 2. Adjust the values manually. Make sure that the values of SP5-045-001 and SP5-302-002 are the same as before replacing.
  - Replace all PM parts because all PM counters will be reset.

**Note**

- If a message states that you need an SD card to restore displays after the NVRAM replacement, create a "SD card for restoration" and restore with the SD card. Refer to page 1-83



## ***NVRAM (EEPROM) on the BiCU***

### **⚠ CAUTION**

- Keep NVRAMs away from any objects that can cause static electricity. Static electricity can damage data in the NVRAM.
1. **Make sure that you have the SMC report (factory settings). This report comes with the machine.**
  2. **Output the SMC log using one of the following methods:**  
To print SMC log data, execute SP5-990-001 ([SP Print Mode]-[All (Data List)]).  
To save SMC log data to an SD card, execute SP5-992-001 ([SP Text Mode]-[All (Data List)]).
  3. **Turn OFF the main power.**
  4. **Insert a blank SD card in SD slot #2, and then turn ON the main power.**
  5. **Upload the NVRAM data from the BiCU using SP5-824-001.**
  6. **Turn OFF the main power and disconnect the power plug.**
  7. **Replace the NVRAM on the BiCU with a new one.**

#### **↓ Note**

- Make sure the NVRAM [A] is installed at the correct mounting location and orientation. Install the NVRAM so that the indentation on the NVRAM corresponds with the mark [B] on the BiCU.
- Incorrect installation of the NVRAM will damage both the BiCU and the NVRAM

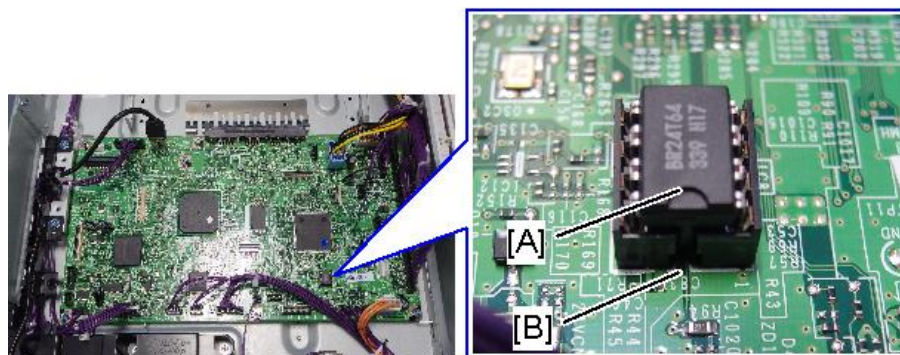

d205m4115

8. **Connect the power plug and turn ON the main power.**
9. **Select the destination setting (SP5-131-001 –NA: 1, EU/AA/TWN/CHN: 2).**

#### **↓ Note**

- After changing the EEPROM, some SPs do not have the correct values.
- Because of this, steps 10 to 12 must be done.

10. **Set SP5-811-001 ([MachineSerial]-[Set]), and SP5-996-001 ([Machine State]-[Destination]).**

#### **↓ Note**

- For information on how to configure the machine serial number and area selection, contact the supervisor in your branch.
- SC995 will appear until the machine serial number and area selection are programmed



correctly.

11. Turn OFF then ON the main power.
12. Do SP5-801-002 to clear the all SP settings for the engine data in NVRAM.
13. Turn OFF then ON the main power.
14. From the SD card where you saved the NVRAM data in step 5, download the NVRAM data with SP5-825-001.
15. Turn OFF the main power.
16. Remove the SD card from slot #2.
17. Turn ON the main power.
18. Check the factory setting sheet and the SMC data printout from step2, and set the user tool and SP settings so that they are the same as before replacement.

### 3.16.5 MAIN POWER SWITCH

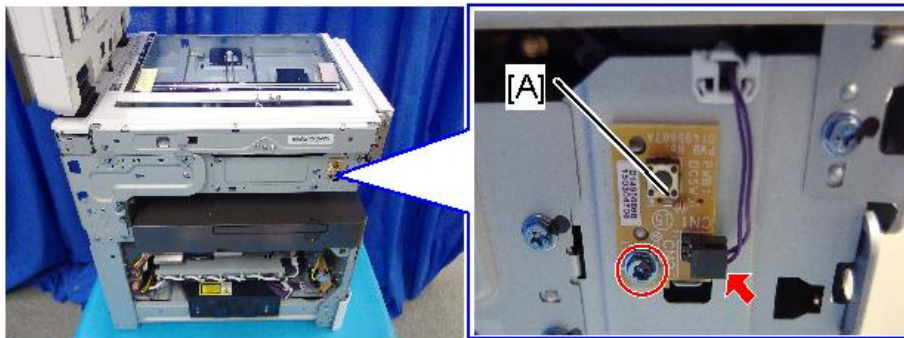
1. Left upper cover (page 3-8)
2. Main power switch [A]



 x1,  x1

d205m4116

### 3.16.6 PSU (POWER SUPPLY UNIT)

#### ⚠ CAUTION

- Do not touch any of the soldered surfaces or any of the components after removing the PSU, because there is residual charge. Also, do not leave the PSU on a conductive metallic area.

1. Paper exit tray (page 3-13)
2. PSU bracket [A]

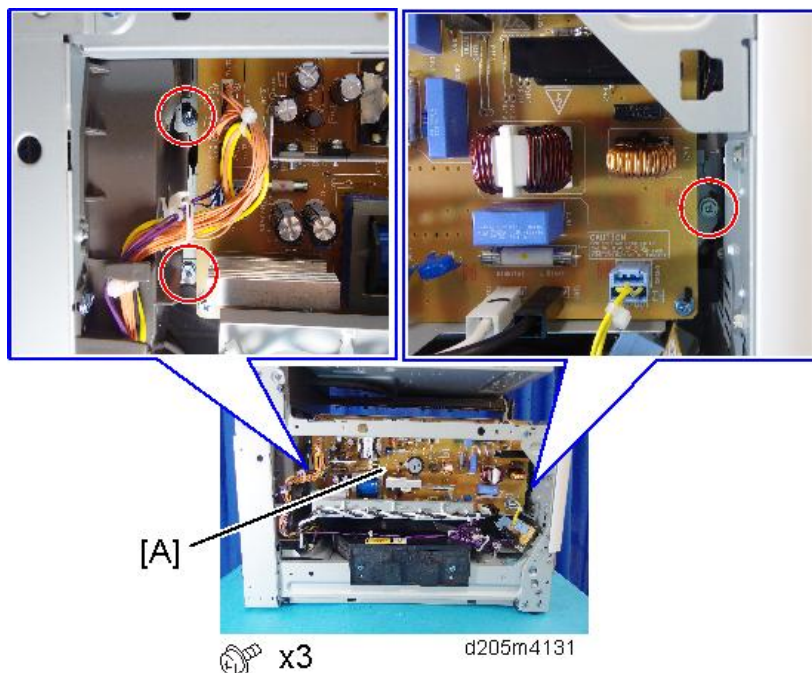

3. Connectors, and clamps

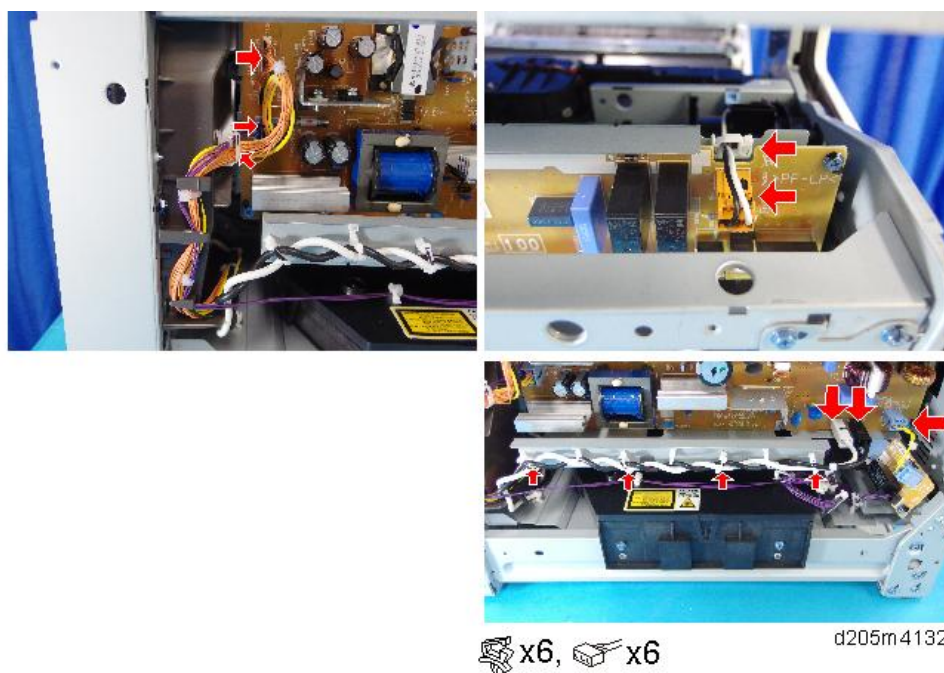

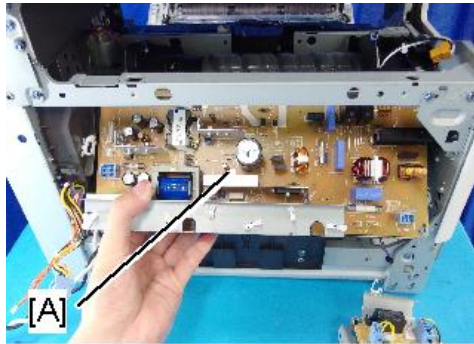

4. PSU bracket [A]

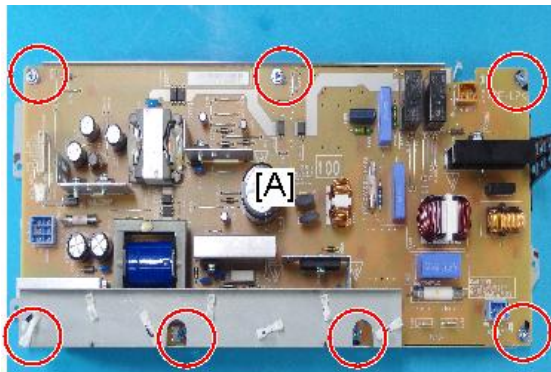

d205m4134

5. PSU [A]



 x7

d205m4135

Replacement  
and Adjustment

### 3.16.7 HVPS (HIGH-VOLTAGE POWER SUPPLY)

1. Rear cover (page 3-5)
2. HVPS [A]



 x4,  x5

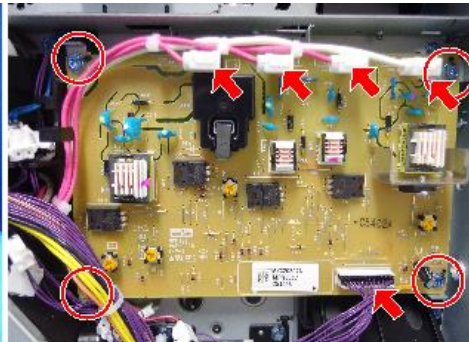

d205m4117



### 3.16.8 FRONT COVER SWITCH

1. Front inner cover (page 3-12)
2. Bracket [A] and front cover switch [B]

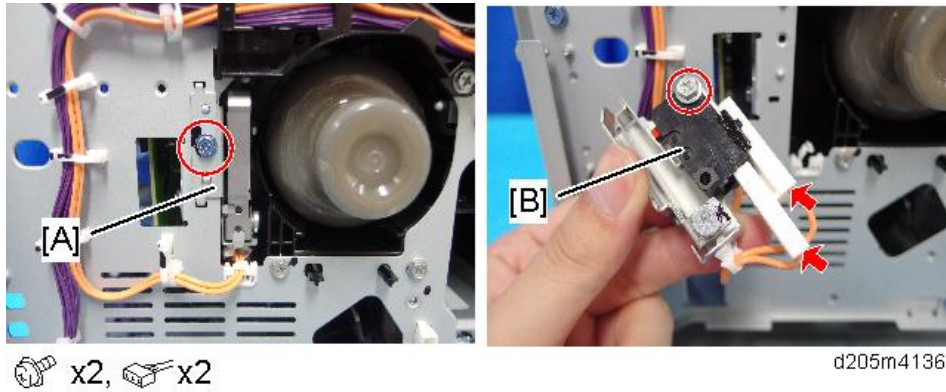

### 3.16.9 RIGHT COVER OPEN/CLOSE SWITCH

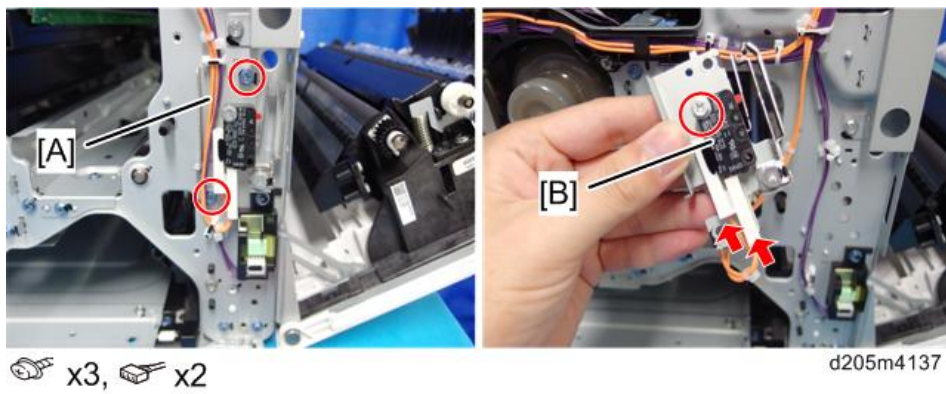

1. Front inner cover (page 3-12)
2. Bracket [A] and right cover open/close switch [B]

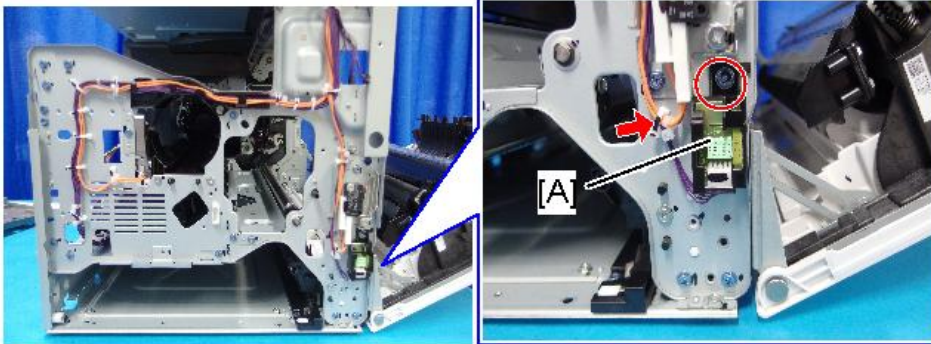

### 3.16.10 TEMPERATURE/HUMIDITY SENSOR

1. Front inner cover (page 3-12)
2. Bracket [A]



 x1,  x1

d205m4138

3. Temperature/Humidity sensor [A]

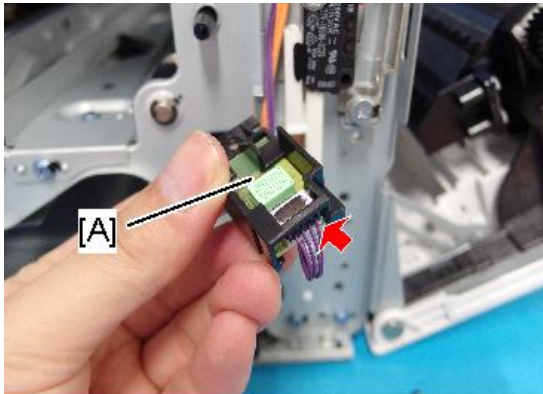

 x1

d205m4139

### 3.16.11 HDD

#### ↓ Note

- Before replacing the HDD, copy the address book data to an SD card with SP5-846-051 if possible.

#### ↓ Note

- To use the Data Overwrite Security, IC card reader, or OCR unit, these applications must be installed again.



1. Refer to the installation procedure. (page 1-46)
2. After replacing the HDD, the HDD will be formatted when you turn ON the main power.
3. When the 'completed' message is displayed, turn OFF the main power.

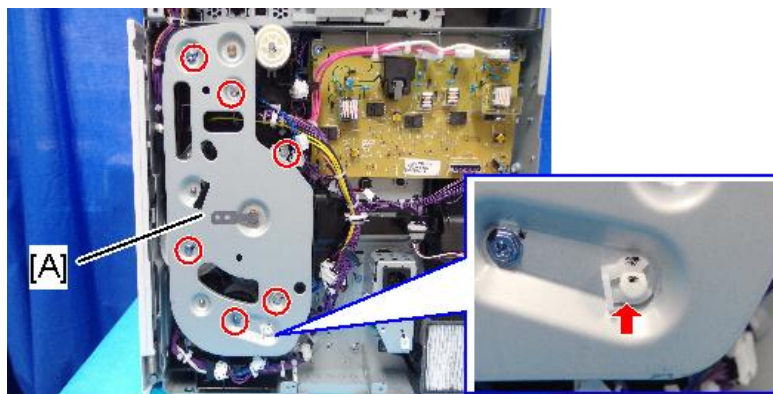

### 3.16.12 MAIN MOTOR

1. Rear cover (page 3-5)
2. Gear bracket [A]



 x6,  x1

d205m4160

3. Gears [A] [B], timing belt [C], and pulley [D]

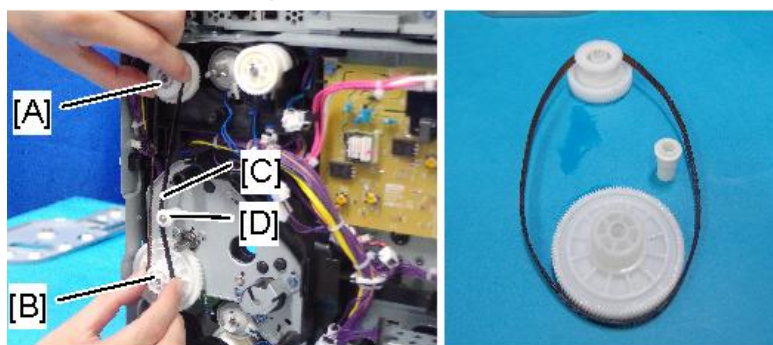

d205m4196

4. Motor bracket [A]

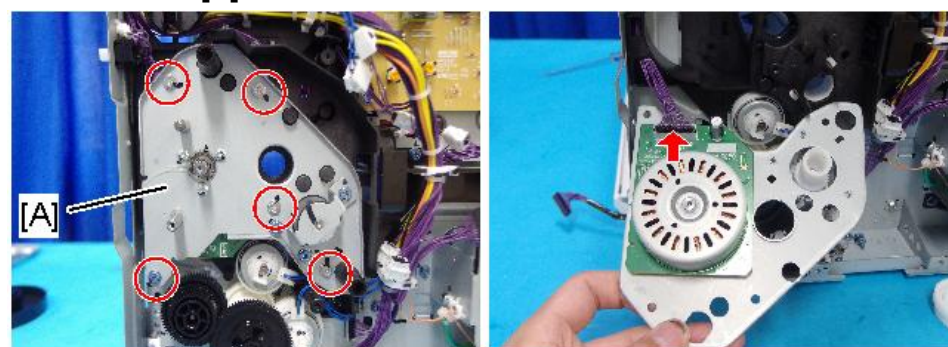

 x5,  x1

d205m4197

 **Important**

- As the motor is attached to the motor bracket using a bonded screw, do not disconnect it from the bracket when you replace it.

5. Before mounting the main motor, apply grease at the following locations [A] on the gear, not on the motor.

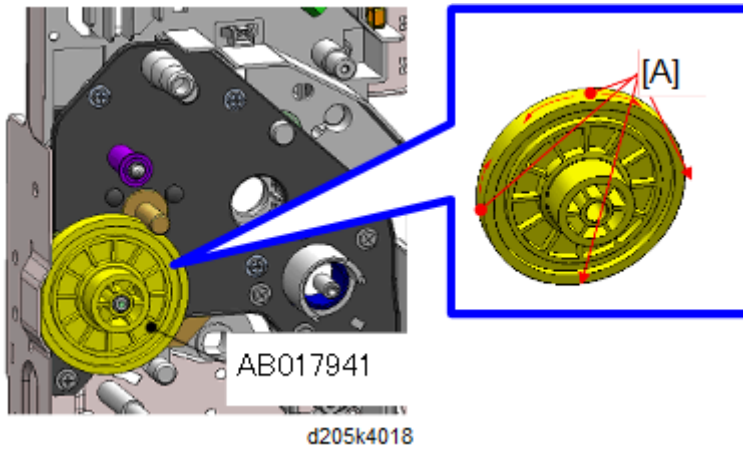

**★ Important**

- Reuse the grease applied to the old part. If the amount of grease applied is insufficient with the minimum amount as shown below, then use the new grease (G-1077).

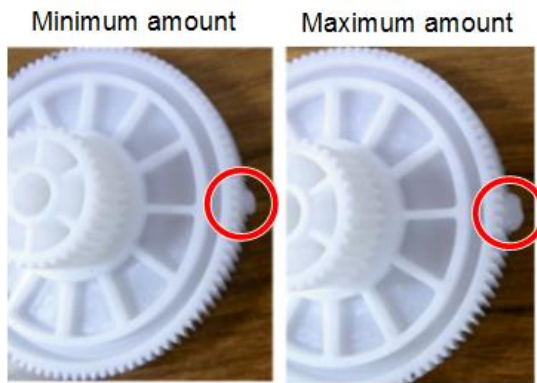

w\_d205k4080

6. Apply grease to following locations [A] on the axes of the motor bracket.

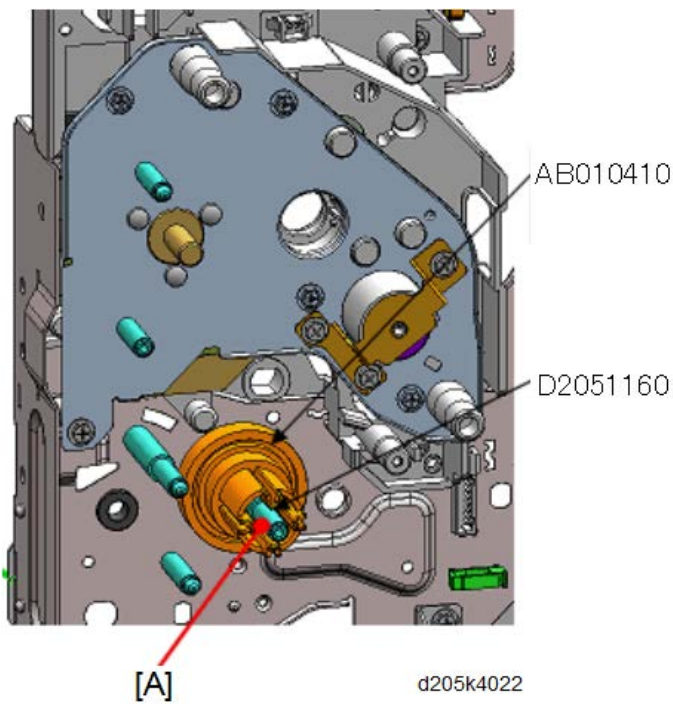
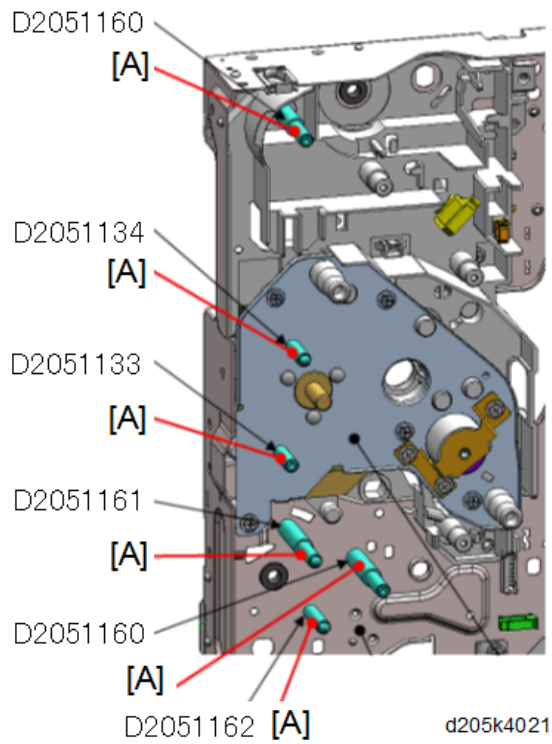

**★ Important**

- Reuse the grease applied to the old part. If the amount of grease applied is insufficient with the minimum amount as shown below, then use the new grease (G-1077).

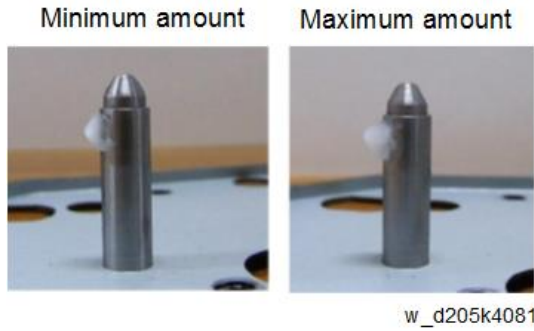

### 3.16.13 INTAKE FAN

1. PCDU (page 3-60)
2. Fusing unit (page 3-84)
3. Open the right cover and remove the duct [A].

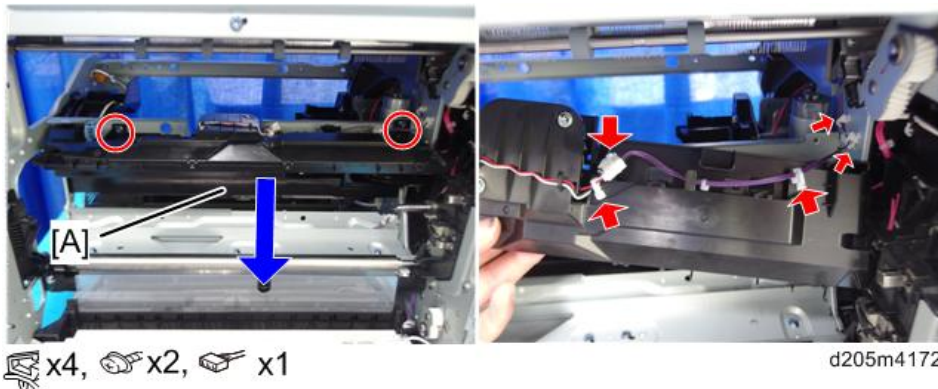

4. Screws

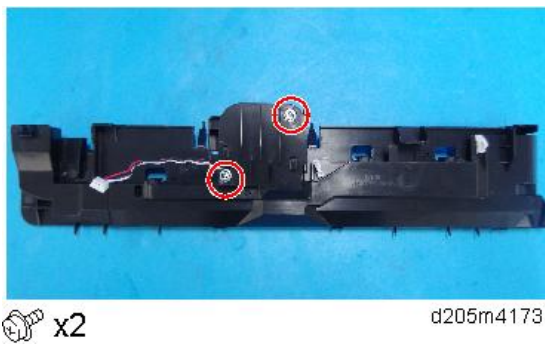

5. Duct upper cover [A] (Hooks x 3)

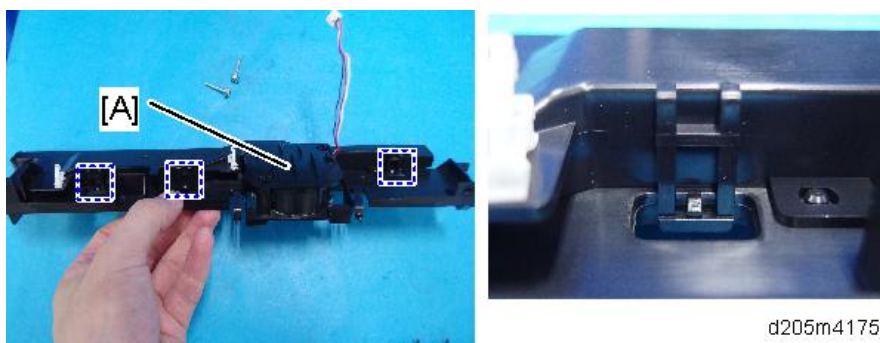



6. Intake fan [A]



d205m4176

### 3.16.14 EXHAUST FAN

1. Rear cover (page 3-5)
2. Duct [A]

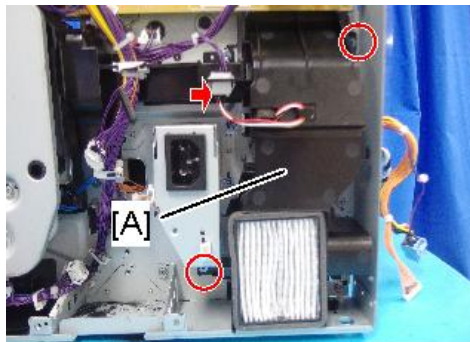

 x2,  x1

d205m4207

3. Release the left and right hooks and remove the duct [A].

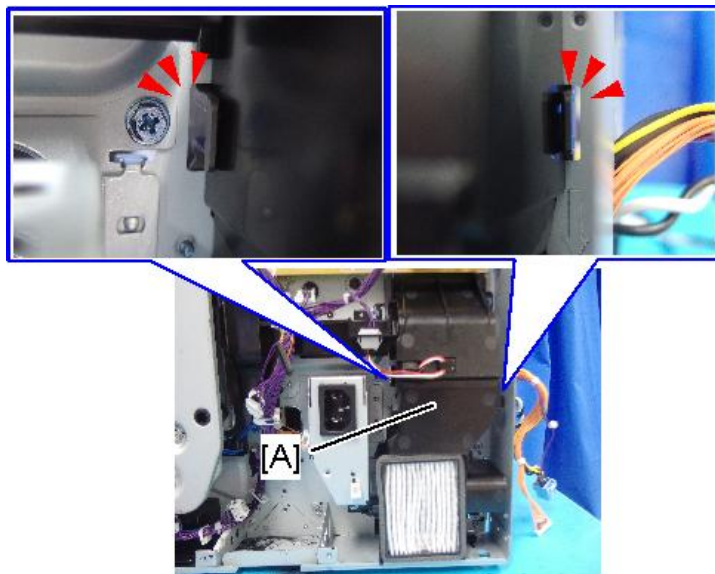

d205m4208

4. Exhaust fan [A]



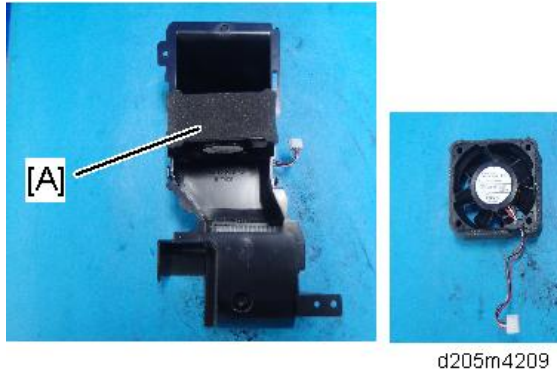

**Notes on Installing the Exhaust Fan**

The indentation on the fan must be installed at the tab on the duct. (The decal pasted on the fan must be at the underside.)

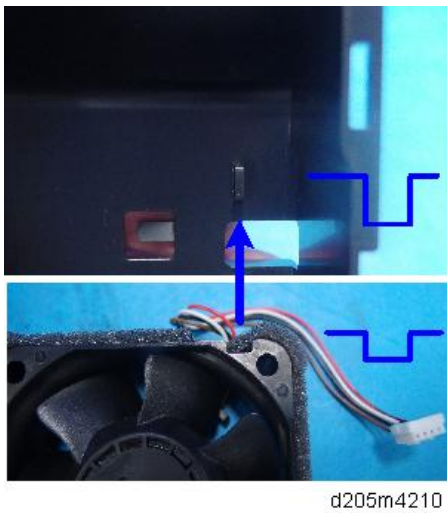

Replacement and Adjustment

**3.16.15 INTERNAL TEMPERATURE SENSOR**

1. Fusing unit (page 3-84)
2. Internal temperature sensor [A]

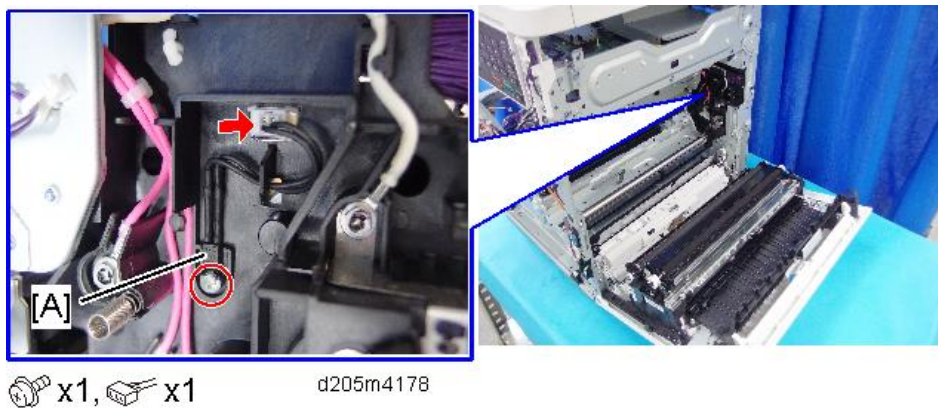

### 3.16.16 DUST FILTER

1. Rear cover (page 3-5)
2. Dust filter [A]

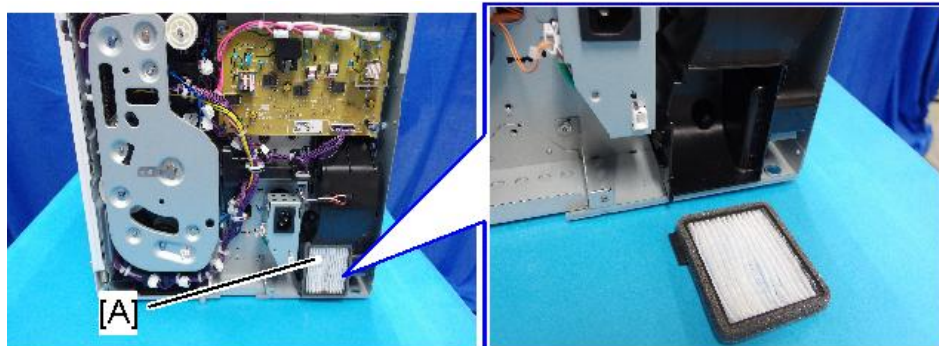

d205m4029

### 3.16.17 CLUTCHES

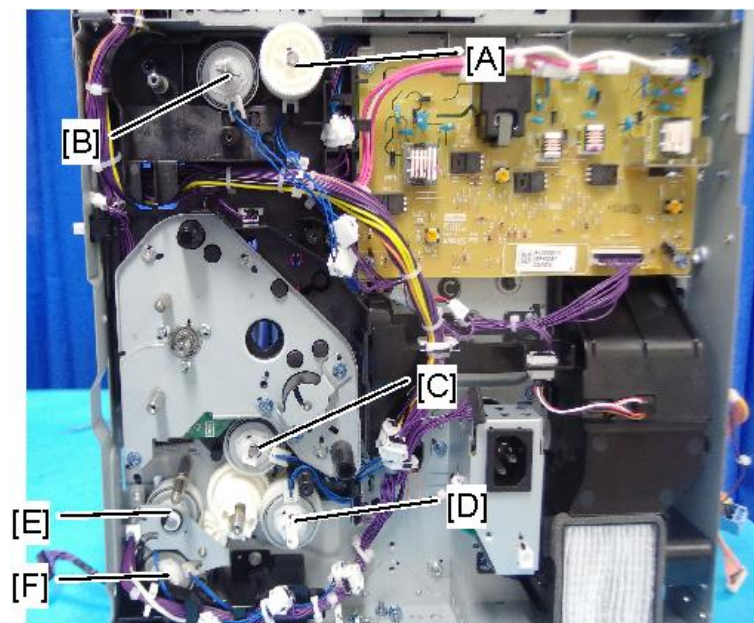

d205m4186

[A]	Paper Exit Clutch	Refer to page 3-97
[B]	Reverse Exit Clutch	
[C]	Registration Clutch	Refer to page 3-74
[D]	Paper Feed Clutch	
[E]	Duplex Reverse Clutch	Refer to page 3-107
[F]	Bypass Clutch	Refer to page 3-110

### Applying the Grease

Apply the new grease (G-1077) at the following locations [A].

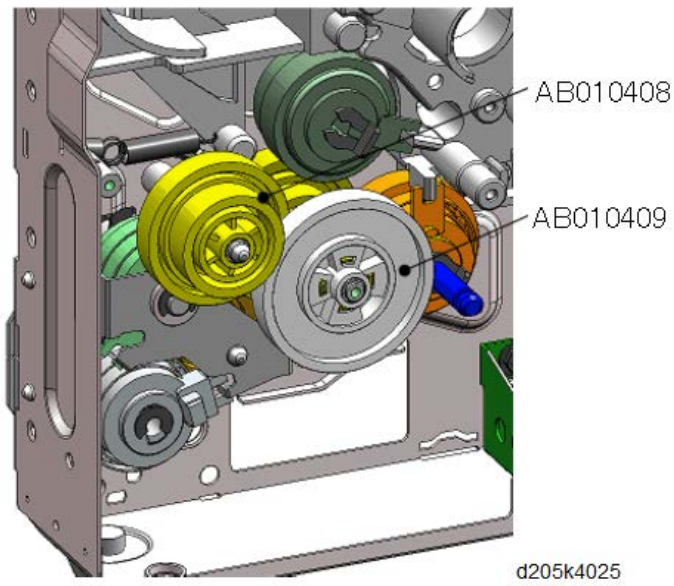
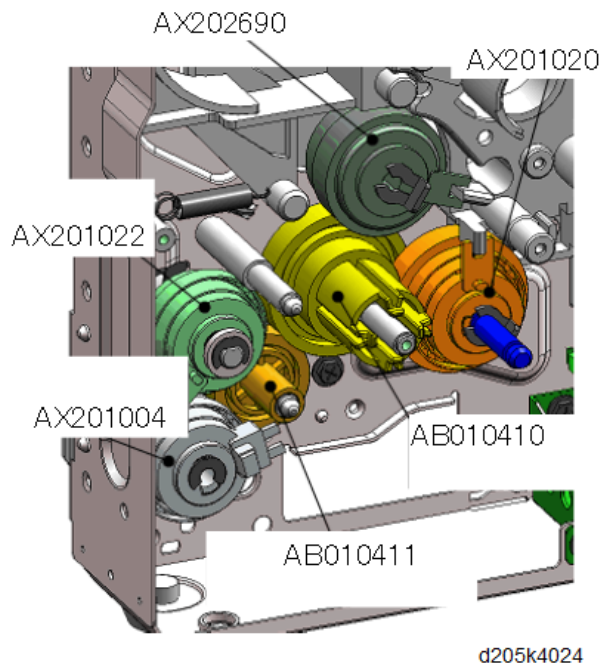

AB010411

Electrical Components, Other Items

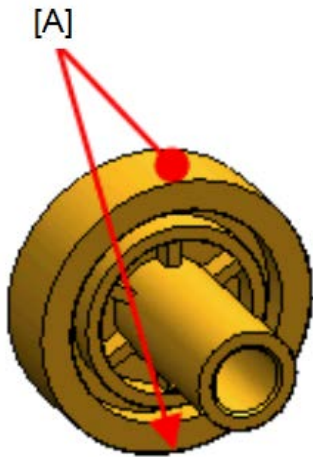

d205k4026

AB010410

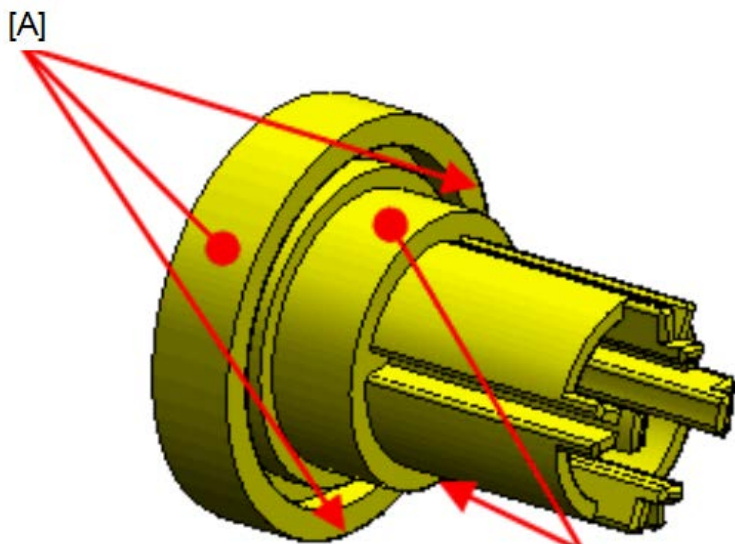

d205k4027

AX201022

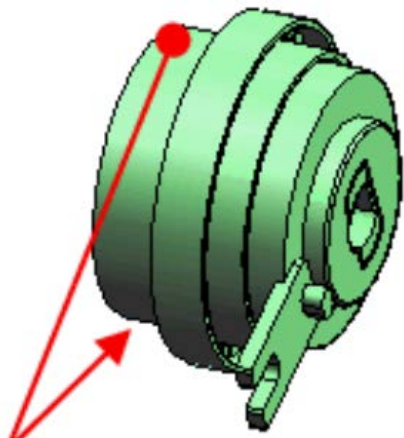

d205k4028

AX201004



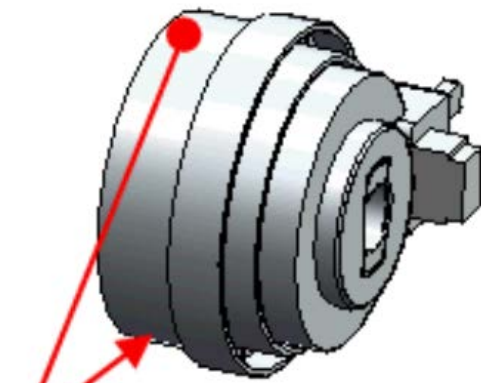

[A]

d205k4029

AX202690

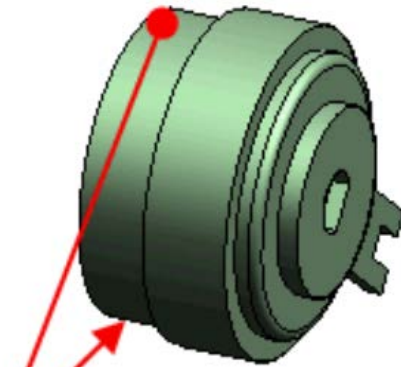

[A]

d205k4030

AX201020

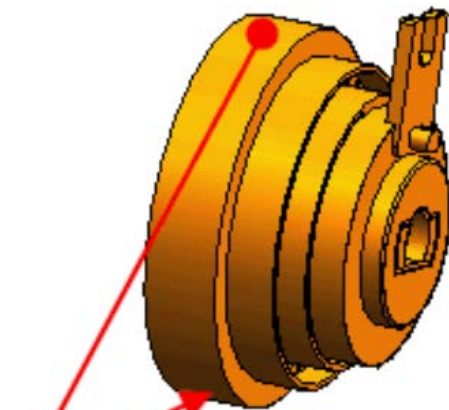

[A]

d205k4031

AB010408



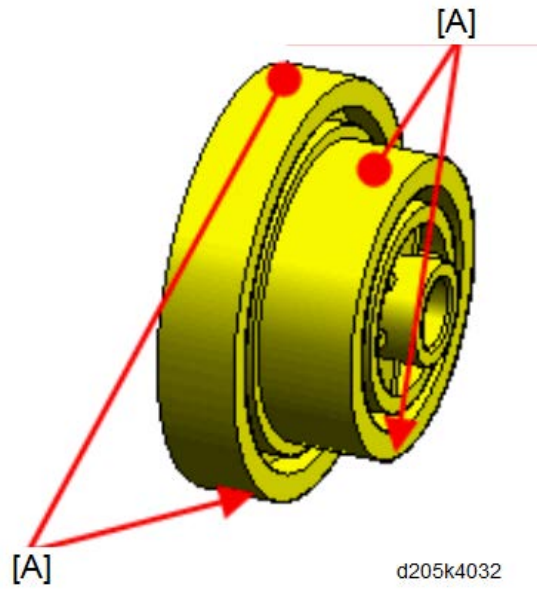

AB010409

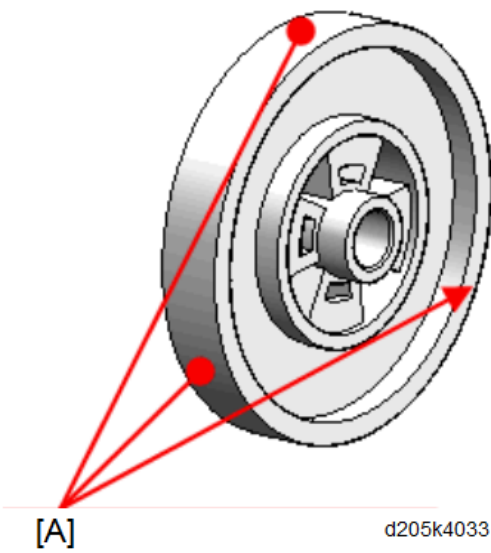

## 3.17 ADJUSTMENT AFTER REPLACEMENT

### ⓘ Note

- Image adjustment is required after clearing memory or replacing or adjusting the parts shown below.
- First scanner or second scanner
- Lens block
- Scanner motor
- Polygon motor
- Paper tray
- Side paper guides
- To access or use the SP mode, refer to page 4-1 "Service Program Mode".

### 3.17.1 PRINTING

#### ⓘ Note

- Make sure the paper is installed correctly in each paper tray before you start these adjustments.
- Use the Trimming Area Pattern (SP2-109-003, No.14) to print the test pattern for the following procedures.
- Set the setting of SP 2-109-003 to "0" again after completing these printing adjustments.

#### ***Registration - Leading Edge/Side-to-Side***

1. Check the leading edge registration for each paper feed station, and adjust them using SP1-001.
2. Check the side-to-side registration for each paper feed station, and adjust them using SP1-002.

**(Adjust Tray 1 first, and then Tray 2.)**

Tray	SP No.	SP Name	Threshold
Tray: Plain	SP1-001-002	Leading edge registration adjustment	2 ±1.5 mm
Tray: MidThick	SP1-001-003	Leading edge registration adjustment	
Tray: Thick	SP1-001-004	Leading edge registration adjustment	

Adjustment after Replacement

Tray	SP No.	SP Name	Threshold
Bypass: Plain	SP1-001-007	Leading edge registration adjustment	
Bypass: MidThick	SP1-001-008	Leading edge registration adjustment	
Bypass: Thick	SP1-001-009	Leading edge registration adjustment	
Duplex: Plain	SP1-001-013	Leading edge registration adjustment	
Duplex: MidThick	SP1-001-014	Leading edge registration adjustment	
Duplex: Thick	SP1-001-015	Leading edge registration adjustment	
Tray 1	SP1-002-001	Side-to-side registration adjustment	
Tray 2	SP1-002-004	Side-to-side registration adjustment	
Duplex	SP1-002-006	Side-to-side registration adjustment	

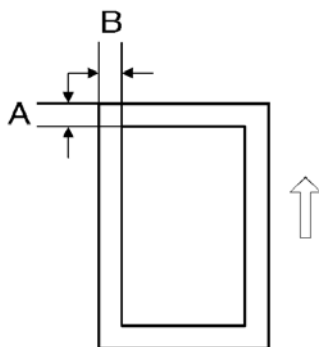

A: Leading Edge Registration

B: Side-to-side Registration

## Blank Margin

### ↓ Note

- If the leading edge/side-to-side registration cannot be adjusted within the specifications, adjust the leading/left side edge blank margin.

1. Check the trailing edge [A] and right edge [B] blank margins, and adjust them using the following SP modes.

Edge	SP No.	SP Name	Adjustment Range
Leading Edge	SP2-103-001	Blank margin adjustment	3 mm (0.0 - 9.0 mm)
Trailing Edge	SP2-103-002	Blank margin adjustment	
Left Edge	SP2-103-003	Blank margin adjustment	2 mm (0.0 - 9.0 mm)
Right Edge	SP2-103-004	Blank margin adjustment	
Duplex: Trailing Edge: L Size	SP2-103-005	Blank margin adjustment	1.2 mm (0.0 - 4.0 mm)
Duplex: Trailing Edge: M Size	SP2-103-006	Blank margin adjustment	0.8 mm (0.0 - 4.0 mm)
Duplex: Trailing Edge: S Size	SP2-103-007	Blank margin adjustment	0.6 mm (0.0 - 4.0 mm)
Duplex: Left Edge	SP2-103-008	Blank margin adjustment	0.3 mm (0.0 - 1.5 mm)
Duplex: Right Edge:	SP2-103-009	Blank margin adjustment	
Duplex: Trailing Edge: L Size: Thick	SP2-103-010	Blank margin adjustment	1 mm (0.0 - 4.0 mm)

## Adjustment after Replacement

Edge	SP No.	SP Name	Adjustment Range
Duplex: Trailing Edge: M Size: Thick	SP2-103-011	Blank margin adjustment	0.6 mm (0.0 - 4.0 mm)
Duplex: Trailing Edge: S Size: Thick	SP2-103-012	Blank margin adjustment	0.4 mm (0.0 - 4.0 mm)
Duplex: Left Edge Thick	SP2-103-013	Blank margin adjustment	0.1 mm (0.0 - 1.5 mm)
Duplex: Right Edge: Thick	SP2-103-014	Blank margin adjustment	

- L Size: Paper Length is 297.1 mm or more
- M Size: Paper Length is 216.1 to 297 mm
- S Size: Paper Length is 216 mm or less.

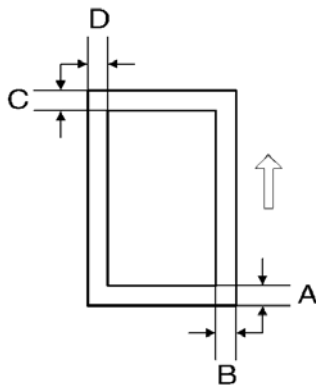

- A: Trailing Edge Blank Margin
- B: Right Edge Blank Margin
- C: Leading Edge Blank Margin
- D: Left Edge Blank Margin



### Main Scan Magnification

1. Use SP2-109-001, no. 7 (Grid Pattern 1, dotted line) to print the single-dot grid pattern.
2. Check the magnification (grid size 2.7 x 2.7), and adjust the magnification using SP2-102-001 (Magnification Adjustment Main Scan) if necessary. The specification is  $100 \pm 1\%$ .

Example:

- (1) Measure 20 grid units in main scanning with the scale
- (2) Check that the measured value is  $54 \text{ mm} \pm 1\%$  (53.46 to 55.54 mm). If the value is outside of the specified range, adjust it using SP.

### 3.17.2 SCANNING

1. Before doing the following scanner adjustments, check and adjust the printing leading-edge and side-to-side registrations and the printing blank margins (as described above).
2. Use an A3 test chart to perform the following adjustments.

#### Registration: Platen Mode

1. Place the test chart on the exposure glass and make a copy from one of the feed stations.  
Use the test chart of SP2-109-001 (Internal test pattern, pattern selection) No. 14.
2. Check the leading edge and side-to-side registration, and adjust as necessary with the following SP modes.

SP No.	SP Name	Specification
SP4-010-001	Side-to-side registration	$0 \pm 1 \text{ mm}$
SP4-011-001	Leading edge registration	$0 \pm 2 \text{ mm}$

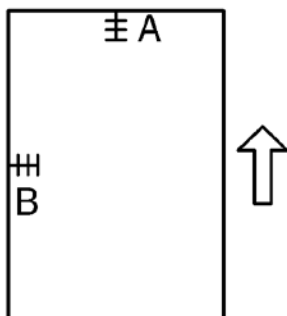

A: Leading edge registration

B: Side-to-side registration

## Adjustment after Replacement

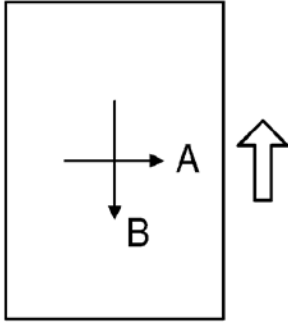

A: Main scan magnification

B: Sub-scan magnification

### Sub-Scan Magnification

1. Place the OS-A3 test chart on the exposure glass and make a copy from one of the feed stations.
2. Check the magnification ratio. If necessary, adjust the magnification with the following SP mode.

SP No.	SP Name	Specification
SP4-008-001	Sub-scan magnification	$\pm 1.0\%$

### 3.17.3 ARDF IMAGE ADJUSTMENT

#### ↓ Note

- Make a test chart (SP2-109-001 Test Pattern Printing) using A3/DLT paper.

#### **Registration/Blank Margin**

- Place the temporary test chart on the ARDF and make a copy from one of the feed stations.

Use the test chart of SP2-109-001 (Internal test pattern, pattern selection) No. 14.

- Check the registration, and adjust using the following SP modes if necessary.

SP No.	SP Name
SP6-006-001	Side-to-side Registration Adjustment: Front
SP6-006-002	Side-to-side Registration Adjustment: Rear
SP6-006-003	Leading Edge Registration Adjustment: Front
SP6-006-004	Leading Edge Registration Adjustment: Rear
SP6-006-007	Trailing Edge Erasing Width Adjustment

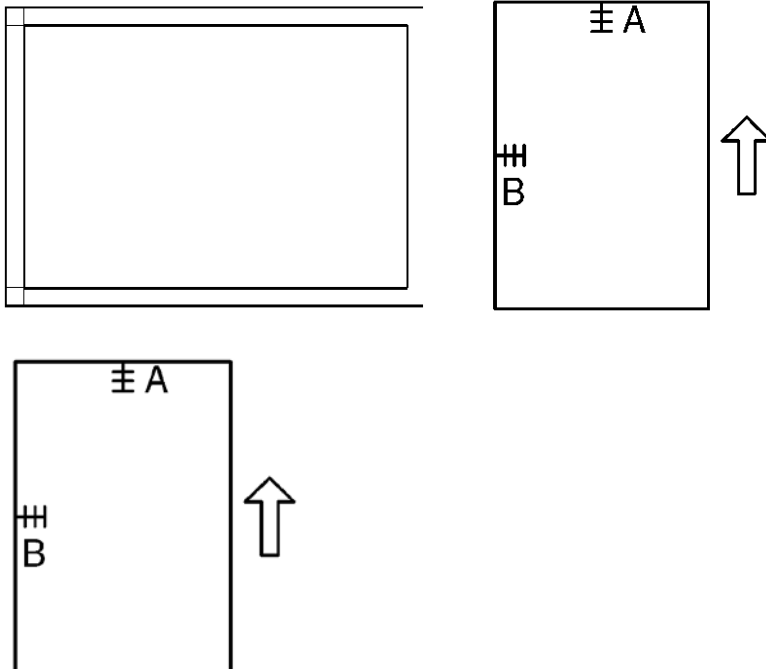

A: Leading Edge Registration

B: Side-to-side Registration

### Sub Scan Magnification

1. Place the temporary test chart on the ARDF and make a copy from one of the feed stations.
2. Check the magnification, and adjust using the following SP modes if necessary.



SP No.	SP Name	Adjustment Range
SP6-017-001	ADF Adjust Mag	±5.0 %

### Skew Adjustment

Distinguish the original and take the necessary action following the flowchart below.

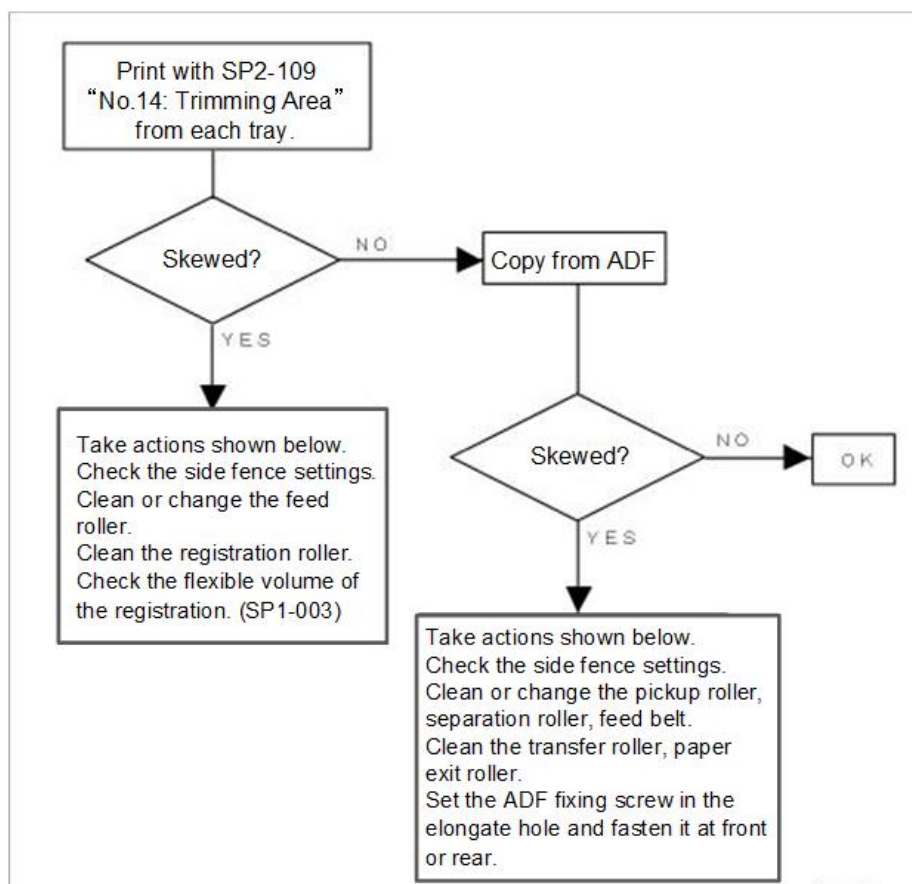

w\_d1589015-en

### Adjustment Procedure

1. Remove the ARDF. (page 3-14)
2. Remove the right hinge.
3. Remove the two parallel pins.
4. Attach the hinge using four screws with the appropriately spaced along the adjustment slots.

Fasten the screws on the right side first.

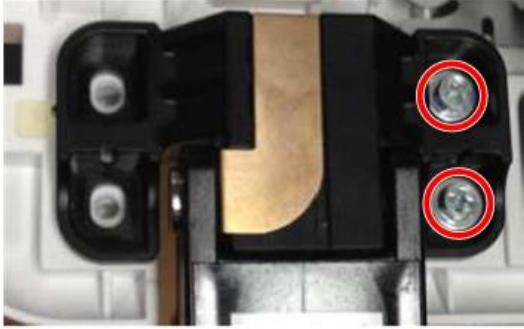

d205k4010



D205k4011

**5. Move the hinge for adjustment, and then fasten the screws.**

Adjustable range is 1.3/200 mm



D205k4012

Adjusting the Direction

**1. Place the original as shown below.**

The original moves to the left.



## Adjustment after Replacement

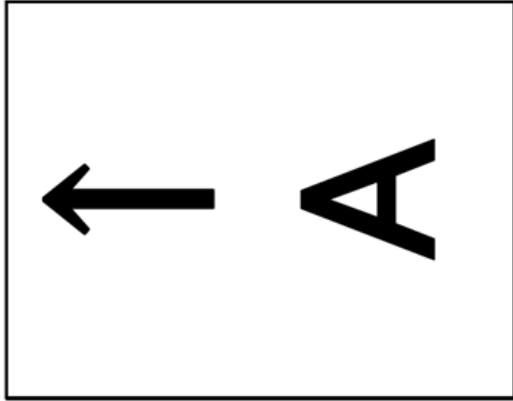

D205k4034

2. If the original is copied as shown below, move the hinge in the direction of the arrow and fasten the screws.

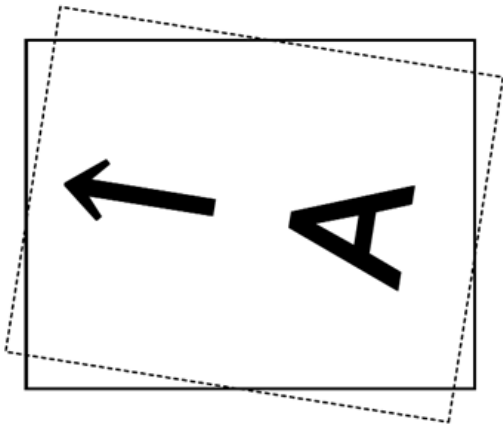

D205k4035

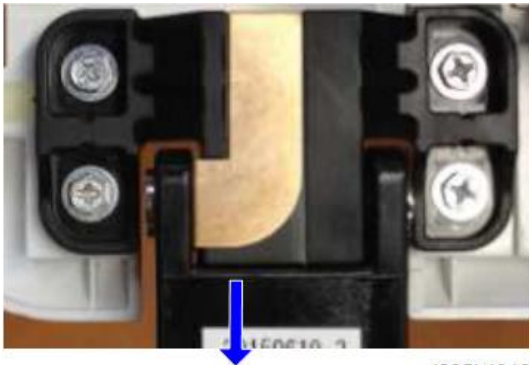

d205k4013

3. If the original is copied as shown below, move the hinge in the direction of the arrow and fasten screws.

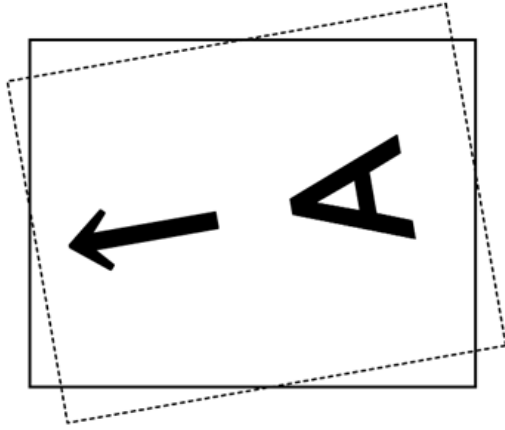

D205k4036

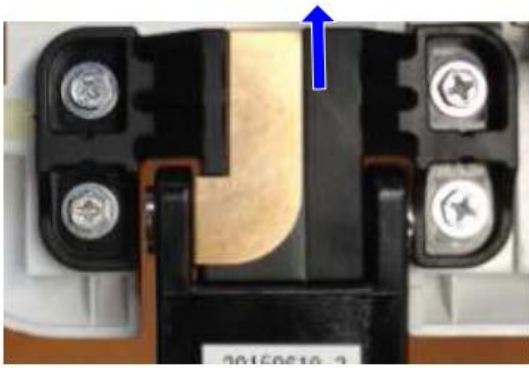

d205k4014



# SYSTEM MAINTENANCE

REVISION HISTORY		
Page	Date	Added/Updated/New
		None





---

## 4. SYSTEM MAINTENANCE

### 4.1 SERVICE PROGRAM MODE

#### CAUTION

- Make sure that the data-in LED (↻) is not on before you go into the SP mode. This LED indicates that some data is coming to the machine. When the LED is on, wait for the copier to process the data.

#### 4.1.1 ENABLING AND DISABLING SERVICE PROGRAM MODE

##### Note

- The Service Program Mode is for use by service representatives only. If this mode is used by anyone other than service representatives for any reason, data might be deleted or settings might be changed. In such case, product quality cannot be guaranteed any more.

#### *Entering SP Mode*

For details, ask your supervisor.

#### *Exiting SP Mode*

- Press "Exit" on the LCD twice to return to the copy window.

#### 4.1.2 TYPES OF SP MODES

- System SP: SP modes related to the engine functions
- Printer SP: SP modes related to the controller functions
- Scanner SP: SP modes related to the scanner functions
- Fax SP: SP modes related to the fax functions

Select one of the Service Program modes (System, Printer, Scanner, or Fax) from the touch panel as shown in the diagram below after you access the SP mode. This section explains the functions of the System/Printer/Scanner SP modes. Refer to the Fax service manual for the Fax SP modes.

## Service Program Mode



d197z3001

### SP Mode Button Summary

Here is a short summary of the touch-panel buttons.

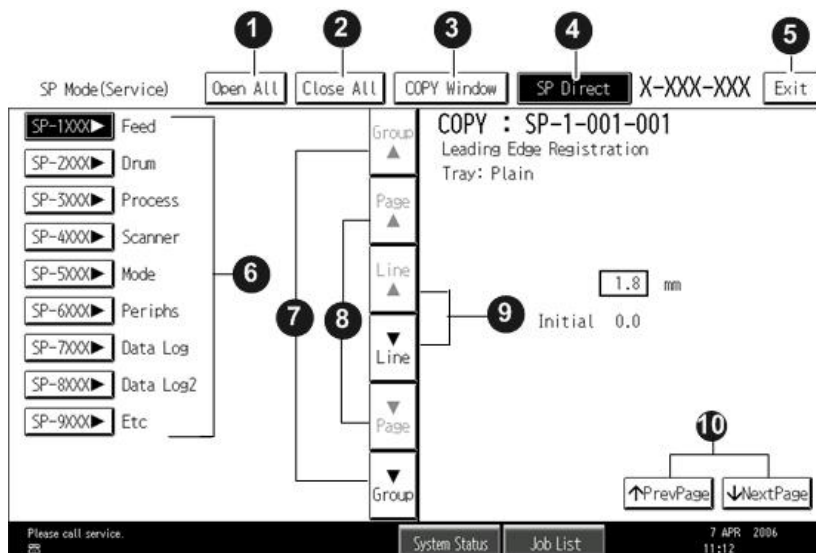

d1353073

1	Opens all SP groups and sublevels.
2	Closes all open groups and sublevels and restores the initial SP mode display.
3	Opens the copy window (copy mode) so you can make test copies. Press SP Mode (highlighted) in the copy window to return to the SP mode screen,
4	Enter the SP code directly with the number keys if you know the SP number. Then press [#]. The required SP Mode number will be highlighted when pressing [#]. If not, just press the required SP Mode number.)

5	Press two times to leave the SP mode and return to the copy window to resume normal operation.
6	Press any Class 1 number to open a list of Class 2 SP modes.
7	Press to scroll the show to the previous or next group.
8	Press to scroll to the previous or next display in segments the size of the screen display (page).
9	Press to scroll the show the previous or next line (line by line).
10	Press to move the highlight on the left to the previous or next selection in the list.

### ***Switching Between SP Mode and Copy Mode for Test Printing***

1. In the SP mode, select the test print. Then press "Copy Window".
2. Use the copy window (copier mode), to select the appropriate settings (paper size, etc.) for the test print.
3. Press [Start] key to start the test print.
4. Press SP Mode (highlighted) to return to the SP mode screen and repeat from step 1.

### ***Selecting the Program Number***

Program numbers have two or three levels.

1. Refer to the Service Tables to find the SP that you want to adjust before you begin.
2. Press the Group number on the left side SP Mode window that contains the SP that you want to adjust.
3. Use the scrolling buttons in the center of the SP mode window to show the SP number that you want to open. Then press that number to expand the list.
4. Use the center touch-panel buttons to scroll to the number and title of the item that you want to set and press it. The small entry box on the right activates and shows the below default or the current settings.

## Service Program Mode

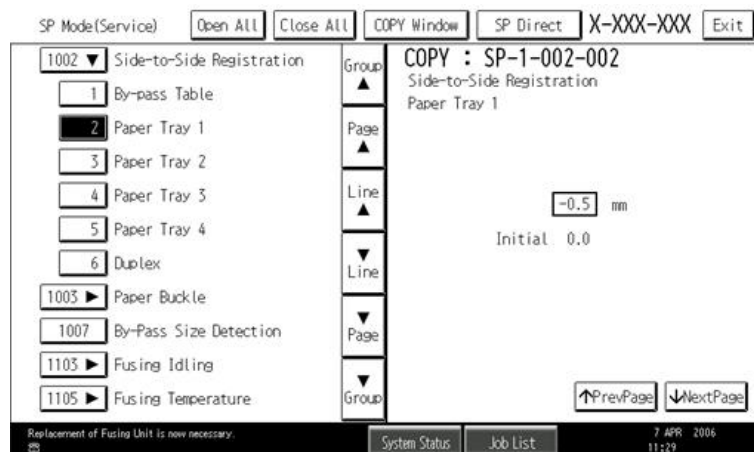

d1353074

### Note

- Refer to the Service Tables for the range of allowed settings.
5. Do this procedure to enter a setting:
    - Press  $\ominus$  to toggle between plus and minus and use the keypad to enter the appropriate number. The number you enter writes over the previous setting.
    - Press [#] to enter the setting. (The value is not registered if you enter a number that is out of range.)
    - Press "Yes" when you are prompted to complete the selection.
  6. If you need to perform a test print, press Copy Window to open the copy window and select the settings for the test print. Press [Start] key and then press SP Mode (highlighted) in the copy window to return to the SP mode display.
  7. Press Exit two times to return to the copy window when you are finished.

### Exiting Service Mode

Press the Exit key on the touch-panel.

## Service Mode Lock/Unlock

At locations where the machine contains sensitive data, the customer engineer cannot operate the machine until the Administrator turns the service mode lock off. This function makes sure that work on the machine is always done with the permission of the Administrator.

1. If you cannot go into the SP mode, ask the Administrator to log in with the User Tool and then set "Service Mode Lock" to OFF after he or she logs in:

User Tools > System Settings > Administrator Tools > Service Mode Lock > OFF

- This unlocks the machine and lets you get access to all the SP codes.
  - The CE can service the machine and turn OFF then ON the machine power. It is not necessary to ask the Administrator to log in again each time the main power is turned ON.
2. Go into the SP mode and set SP5-169 to "1" if you must use the printer bit switches.
  3. After machine servicing is completed:
    - Change SP5-169 from "1" to "0".
    - Turn OFF then ON the machine power. Tell the administrator that you have completed servicing the machine.
    - The Administrator will then set the "Service Mode Lock" to ON.

## PM Counter/ Firmware Update

PM Counter and Firmware Update can be entered in the SP mode main screen.

- PM Counter: PM counters for each PM part
- Firmware Update: Immediate remote update and remote update at next visit



### <How to Check the PM Counter>

1. Enter the SP mode, and then press [PM Counter].

## Service Program Mode



d197z3002

2. Press [Estimated Usage Rate/Estimated Remain Days].

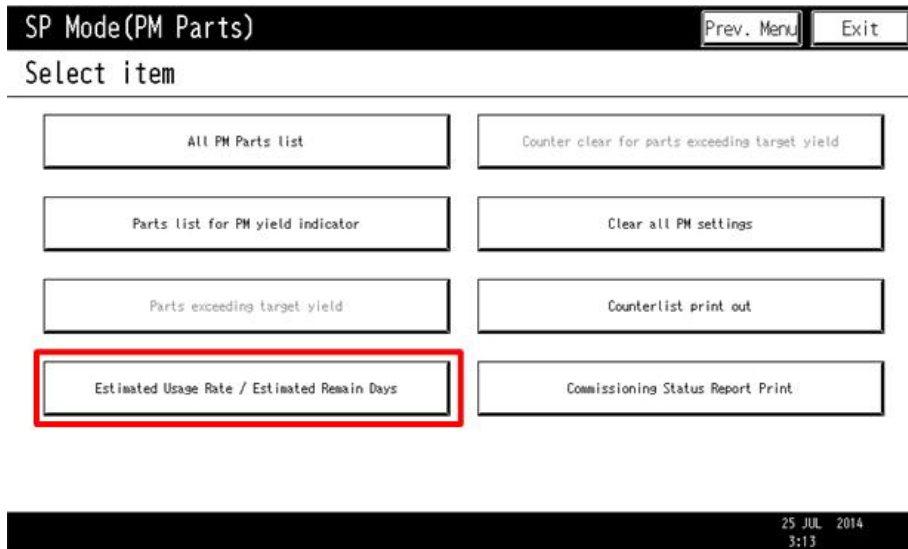

d197z3003

3. You can see the “Remaining Days for each part”.

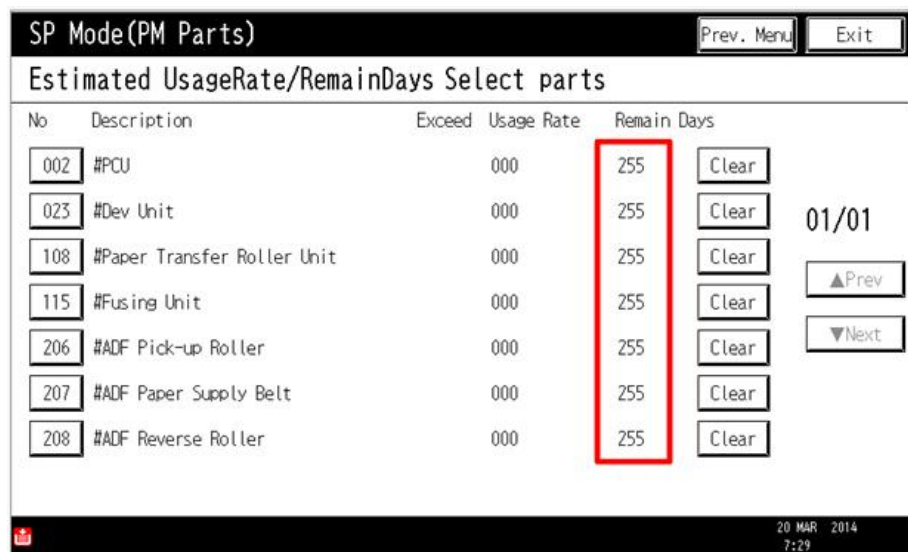

d197z3004



### <How to Use the Firmware Update>

For details about how to use the Firmware Update, refer to Package Firmware Update.

### 4.1.3 REMARKS

The maximum number of characters which can show on the control panel screen is limited to 30 characters. For this reason, some of the SP modes shown on the screen need to be abbreviated. The following are abbreviations used for the SP modes for which the full description is over 20 characters.

Item	Description
Paper Weight	Thin paper: 52-59 g/m <sup>2</sup> , 13.9-15.7lb. Plain Paper1: 60-74 g/m <sup>2</sup> , 16-19.7lb. Plain Paper2: 75-81 g/m <sup>2</sup> , 20-21.6lb. Middle Thick: 82-105 g/m <sup>2</sup> , 21.9-28lb. Thick Paper1: 106-157 g/m <sup>2</sup> , 28.3-41.9lb.
Paper Type	N: Normal paper MTH: Middle thick paper TH: Thick paper
Paper Feed Station	P: Paper tray B: By-pass table
Print Mode	S: Simplex D: Duplex

### Others

The settings of each SP mode are explained in the right-hand column of the SP table in the following way.

[Adjustable range / **Default setting** / Step] Alphanumeric

#### ↓ Note

- If "Alphanumeric" is written to the right of the bracket as shown above, the setting of the SP mode shows on the screen using alphanumeric characters instead of only numbers. However, the settings in the bracket in the SP mode table are explained by using only the numbers.

The following symbols are used in the SP mode tables.

Notation	What it means
<b>ENG</b>	Engine SP
<b>CTL</b>	Controller SP
<b>FA</b>	Factory setting: Data may be adjusted from the default setting at the factory. Refer to the factory setting sheets enclosed. You can find it in the front cover.
<b>DFU</b>	Design/Factory Use only: Do not touch these SP modes in the field.
*	<p>An asterisk (*) to the left side of ENG/CTL column means that this mode is stored in the NVRAM. If you do a RAM clear, this SP mode will be reset to the default value. "ENG" and "CTL" show which NVRAM contains the data.</p> <ul style="list-style-type: none"> <li>▪ *ENG: NVRAM on the BiCU board</li> <li>▪ *CTL: NVRAM on the controller board</li> </ul>
<b>SSP</b>	This denotes a "Special Service Program" mode setting.

## 4.2 TEST PATTERN PRINTING

Printing Test pattern: SP2-109

Some of these test patterns are used for copy image adjustments but most are used primarily for design testing.

### ⬇ Note

- Do not operate the machine until the test pattern is printed out completely. Otherwise, SC will occur.

- Enter the SP mode.
- Press SP2-109-001.
- Select test pattern for print from the list, and then press [OK].
- To change the density of the test pattern, select the density with SP2-109-002, then press [#].

### ⬇ Note

- If the value of SP2-109-002 is selected to 0, the color adjusted so will not show up in the test pattern.
- To print, press [Copy Window], and then set settings within the following window for test print (paper size etc...).
  - Press [Start] to start test print.
  - After checking test pattern, press [SP Mode] on the screen to return to SP mode display.
  - Reset all settings to the default values with SP2-109-003 and SP2-109-006.
  - Exit SP mode.

No.	Pattern	No.	Pattern
0	None	13	4dot Ind. Pptrn (4dot Independent Pattern)
1	1dot Vertical Line	14	Trimming Area
2	2dot Vertical Line	15	Hounds tooth H
3	1dot Horizontal Line	16	Hounds tooth V
4	2dot Horizontal Line	17	Black Band H (Horizontal)
5	Grid Vert (Grid Vertical Line)	18	Black Band V (Vertical)
6	Grid Horizontal (Grid Horizontal Line)	19	Checker Flag Pattern
7	Grid Pattern Small	20	Grayscale V (Vertical)

Test Pattern Printing

No.	Pattern	No.	Pattern
8	Grid Pattern Large	21	Grayscale H (Horizontal)
9	Argyle Pattern Small	22	2 Beam Density Pptrn
10	Argyle P:L (Argyle Pattern Large)	23	Full Dot Pattern
11	1dot Ind. Pptrn (1dot Independent Pattern)	24	All White Pattern
12	2dot Ind. Pptrn (2dot Independent Pattern)	-	-

## 4.3 FIRMWARE UPDATE

### 4.3.1 OVERVIEW

In order to update the firmware of this machine, it is necessary to download the latest version of firmware on a SD card.

Insert the SD card in SD card slot 2 beside the left rear of the controller box.

### 4.3.2 FIRMWARE TYPE

Firmware type	Function	Firmware location	Message display
System/Copy	Operating system	Controller board	System/Copy
Engine		BiCU	Engine
Control panel		Control panel	Lcdc
Network support		Controller board	Network Support
Language 1		Control panel	Language 1
Language 2		Controller board	Language 2
RPCS		Controller board	RPCS
PCL (PCLXL)		Controller board	PCL (PCLXL)
Media print JPEG/TIFF		Controller board	MediaPrint:JPEG/TIF
Font		Controller board	FONT
Font 1		Controller board	FONT1
Network document box		Controller board	NetworkDocBox
Printer		Controller board	Printer
Scanner		Controller board	Scanner
Web support		Controller board	Websupport
Web Application		Controller board	WebUapl

**Note**

- Even when not using a RPCS driver, the XPS driver requires RPCS firmware.

### 4.3.3 PROCEDURE

**Important**

- A SD card is a precision device, so when you handle an SD card, respect the following.
- When the power is turned ON, do not insert or remove a card.
- During installation, do not turn OFF the main power.
- Since the card is manufactured to high precision, do not store it in a hot or humid location, or in direct sunlight.
- Do not bend the card, scratch it, or give it a strong shock.
- Before downloading firmware on an SD card, check whether write-protection of the SD card is canceled. If write-protection is enabled, an error code (error code 44, etc.) will be displayed during download, and the download will fail.
- Before updating firmware, remove the network cable from this machine.
- If SC818 is generated during software update, turn OFF then ON the main power, and complete the update which was interrupted.
- During software update, network cables, remove interface cables, wireless boards, etc., (so that they are not accessed during update).

#### **Update procedure**

1. First download the software to be updated to the SD card.
2. Turn OFF the main power.
3. Remove the SD card slot cover [A].

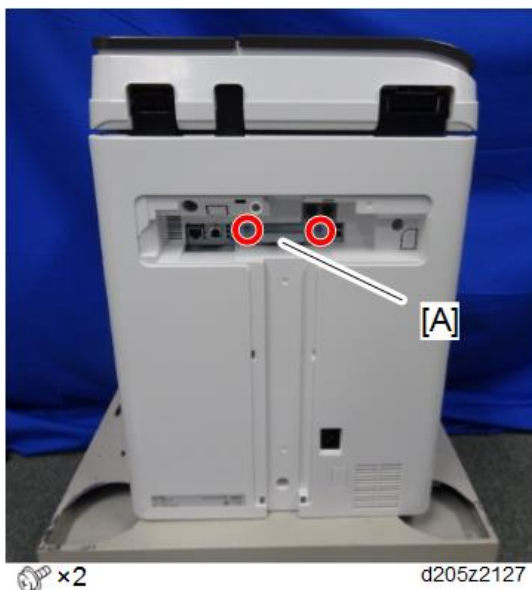

4. Insert the SD card straight in slot 2 [B].



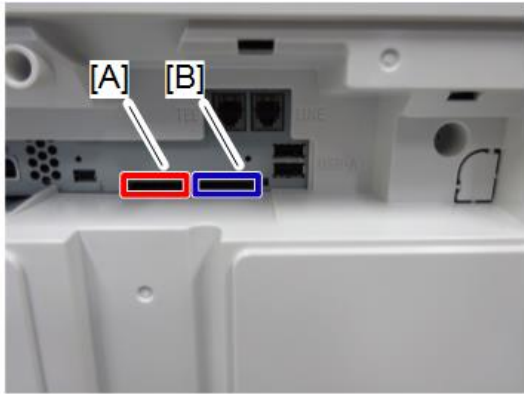

d205z2128

**Note**

- Check whether the card is properly in the SD card slot. When a SD card is inserted, a click is heard, and it is locked.
- To remove the card, release by pressing once in the set state.

5. Turn ON the main power.
6. Wait until the update screen starts (about 45 seconds).  
When it appears, "Please Wait" is displayed.
7. Check whether a program installation screen is displayed. (English display) When two or more software modules are contained in the SD card, they are displayed as follows.

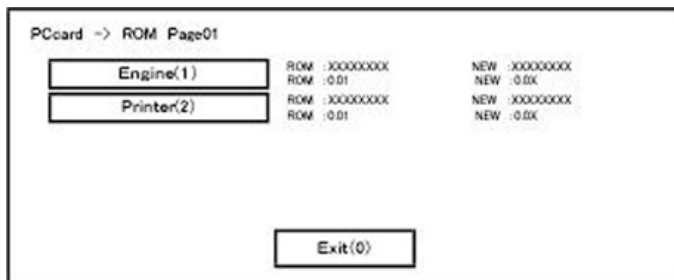

**When two or more software names are displayed**

1. Press the module selection button or 10 keypad [1] - [5].
2. Choose the appropriate module. (If already selected, cancel the selection)

**Operation of keys or buttons**

Keys or buttons to press	Contents
[Exit] or 10 key [0]	Returns to normal screen.
[Start] Key	Select all modules.
[Clear/Stop] key	Cancel all selection states.

**Display contents**

On the above screen, two programs, i.e., engine firmware and printer application are displayed. (The screen may change depending on the firmware or application).

The display contents are as follows:

Display	Contents
ROM:	Display installed module number / version information.
NEW:	Display module number / version information in the card.

\* The upper row corresponds to the module number, the lower row corresponds to the version name.

8. Select the module with the module selection button or 10 key operation. The selected module is highlighted, and [Verify] and [Update] are displayed.

**Note**

- Depending on the combination of update software, it may not be possible to select simultaneously.

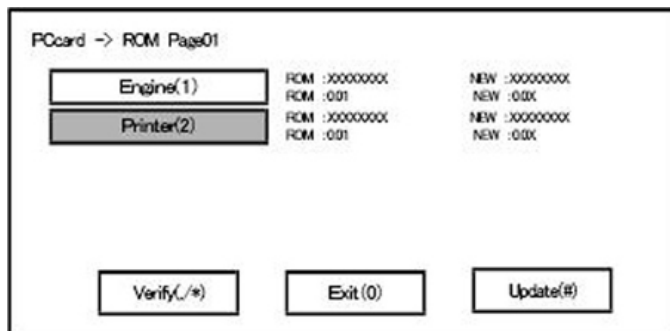

**Key or button operations**

Keys or buttons to press	Contents
[Update] or [#] key	Update the ROM of the selected module.
[Verify] button or [./*] key	Perform verification of the selected module.

9. Press the [Update] or [#] key, and perform software update.
10. During firmware update, a "firmware update/ verification progress screen" is displayed. When firmware update is complete, a "firmware update end screen" is displayed.

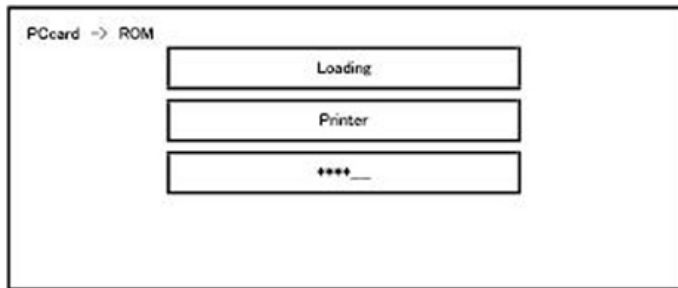

- In the middle row, the name of the module currently being updated is displayed. (in this case, the printer is being updated)
- In the lower row, a progress bar is displayed in ten steps. (The more \*, the more the progress.)
- When updating the control unit program, since progress cannot be displayed on the screen, the ROM update process is determined when the LED of the [Start] key changes from red to green.

#### Firmware update end screen

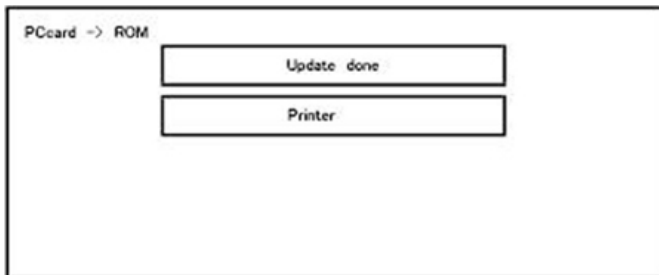

- This screen is displayed when all selected firmware modules are to be updated. "printer" in the second row shows that the module updated last is the printer. (When more than one are updated simultaneously, only what was updated last is displayed.)
- When Verify has completed normally, the Update done display of the above screen is "Verify done." If "Verify Error" is displayed, reinstall the software of the application displayed in the lower row.

11. After turning OFF the main power, remove the SD card.

12. Again, turn ON the main power, and check whether the machine is operating normally.

13. Return the SD card slot cover to the original position.

#### **Note**

- When the main power is turned OFF during firmware update, update is interrupted, and the main power is turned ON again, normal operation cannot be guaranteed.
- To guarantee operation, an update error continues to be displayed until update is successful.
- In this case, insert the SD card again, turn ON the main power, and continue download of firmware from the SD card automatically.
- Web access card software: EXJS (EXtended Java Script) is a Type-C ESA application, and like a conventional Web access card, update using an sdk folder is required.
- The PS3 firmware program is included in the preinstalled PDF firmware.

- In the default state, although the PS3 firmware program is hidden in the disabled state, the function is enabled by installing the PS3 card.
- (The program installed in the PS3 card is a dongle (key) for enabling PS3 function).
- Due to the above specification, the self-diagnosis result report shows the ROM module number / software version of the PDF firmware at the PS location.

### 4.3.4 ERROR SCREENS DURING UPDATING

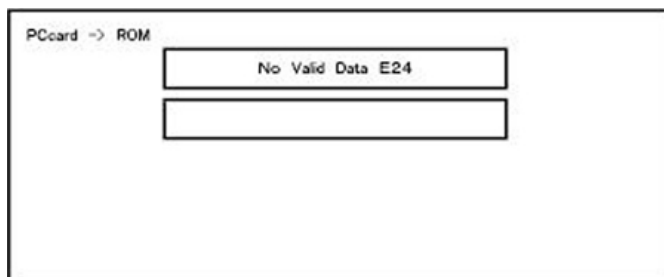

E24 shows an error code.

(This error is generated if update was performed when a printer application startup card is removed after system startup. An error indicating failure of card access is displayed on the screen.)

For error codes, refer to the following table:

#### Error Code List

Code	Contents	Solutions
20	Physical address mapping cannot be performed.	<ul style="list-style-type: none"> <li>▪ Turn OFF then ON the main power to try again.</li> <li>▪ Re-insert the SD card to reboot it.</li> <li>▪ Replace the controller board if the above solutions do not solve the problem.</li> </ul>
21	Insufficient memory for the download	<ul style="list-style-type: none"> <li>▪ Turn OFF then ON the main power to try again.</li> <li>▪ Replace the controller board if the updating cannot be done by turning OFF then ON the main power.</li> </ul>

Code	Contents	Solutions
22	Decompression of compressed data failed.	<ul style="list-style-type: none"> <li>▪ Turn OFF then ON the main power to try again.</li> <li>▪ Replace the SD card used for the update.</li> <li>▪ Replace the controller board if the above solutions do not solve the problem.</li> </ul>
24	SD card access error	<ul style="list-style-type: none"> <li>▪ Re-insert the SD card.</li> <li>▪ Turn OFF then ON the main power to try again.</li> <li>▪ Replace the SD card used for the update.</li> <li>▪ Replace the controller board if the above solutions do not solve the problem.</li> </ul>
32	<p>The SD card used after download suspension is incorrect.</p> <p>SD cards are different between the one which was inserted before power interruption and the one which was inserted after power interruption.</p>	<ul style="list-style-type: none"> <li>▪ Insert the SD card containing the same program as when the firmware update was suspended, and then Turn OFF then ON the main power to try again.</li> <li>▪ There is a possibility that the SD card is damaged if the update cannot be done after the correct SD card has been inserted. In this case, try again with a different SD card.</li> <li>▪ Replace the controller board if the above solutions do not solve the problem.</li> </ul> <p>Replace all relevant boards if the update is done for the BiCU and FCU. Replace the operation panel unit if the update is done for the operation panel.</p>
33	Card version error. The wrong card version is downloaded.	<ul style="list-style-type: none"> <li>▪ Install the correct ROM update data for each version in the SD card.</li> </ul>

Code	Contents	Solutions
34	Destination error. A card for the wrong destination is inserted.	<ul style="list-style-type: none"> <li>Install the correct ROM update data for each destination (JPN/ EXP/ OEM) in the SD card.</li> </ul>
35	Model error. A card for the wrong model is inserted.	<ul style="list-style-type: none"> <li>Install the correct ROM update data for each model in the SD card.</li> </ul>
36	Module error. The program to be downloaded does not exist on the main unit. The download destination specified by the card does not match up to the destination for the main unit's program.	<ul style="list-style-type: none"> <li>Install the program to be updated in advance.</li> <li>There is a possibility that the SD card containing the program to be updated has not been mounted. Check to confirm that the SD card has been correctly mounted.</li> <li>The SD card is incorrect if the program to be updated has been correctly installed. In this case, insert the correct SC card.</li> </ul>
38	The version of the downloaded program has not been authorized for the update.	<ul style="list-style-type: none"> <li>Make sure that the program to be overwritten is the specified version.</li> </ul>
40	Engine download fails.	<ul style="list-style-type: none"> <li>Turn OFF then ON the main power to try again.</li> <li>If the download fails again, replace the controller board and the BiCU.</li> </ul>
41	Fax download fails.	<ul style="list-style-type: none"> <li>Turn OFF then ON the main power to try again.</li> <li>If the download fails again, replace the controller board and the FCU board.</li> </ul>
42	Control panel / language download fails.	<ul style="list-style-type: none"> <li>Turn OFF then ON the main power to try again.</li> <li>If the download fails again, replace the controller board and the operation panel unit.</li> </ul>



Code	Contents	Solutions
43	Printing download fails.	<ul style="list-style-type: none"> <li>▪ Turn OFF then ON the main power to try again.</li> <li>▪ The SD card media is damaged if the update fails again. Replace the SD card media.</li> </ul>
44	The data to be overwritten cannot be accessed when controller-related programs are downloaded.	<ul style="list-style-type: none"> <li>▪ Turn OFF then ON the main power to try again.</li> <li>▪ Install the correct ROM update data in the SD card.</li> <li>▪ Replace the controller board if the data to be overwritten is contained on the controller board.</li> </ul>
49	Firmware updates are currently prohibited.	<ul style="list-style-type: none"> <li>▪ The setting of Update Firmware in the Administrator Tools has been set to [Prohibit] by an administrator. Amend the setting to [Do not Prohibit] and try again.</li> </ul>
50	The results of the electronic authorization check have rejected the update data.	<ul style="list-style-type: none"> <li>▪ Install the correct ROM update data in the SD card.</li> </ul>
57	@Remote is not connected at the date/time reserved for receiving the package firmware update from the network.	<ul style="list-style-type: none"> <li>▪ Check the @Remote connection.</li> </ul>
58	Update cannot be done due to a reception route problem.	<ul style="list-style-type: none"> <li>▪ Check the @Remote connection.</li> </ul>
59	HDD is not mounted.	<ul style="list-style-type: none"> <li>▪ Check the HDD connection.</li> </ul>
60	HDD could not be used during the package firmware update.	<ul style="list-style-type: none"> <li>▪ Try again.</li> <li>▪ Replace the HDD if the download fails again.</li> </ul>

## Firmware Update

Code	Contents	Solutions
61	The module ID for the package firmware update is incorrect.	<ul style="list-style-type: none"> <li>Prepare the correct package files.</li> </ul>
62	The configuration of the package firmware update files is incorrect.	<ul style="list-style-type: none"> <li>Prepare the correct package files.</li> </ul>
63	Reception fails due to the power off at the reserved date/time of the remote firmware update from the network.	<ul style="list-style-type: none"> <li>Update is to be done automatically when the next reception time has elapsed.</li> </ul>
64	Reception fails due to the power off at the reserved date/time of the package firmware update from the network.	<ul style="list-style-type: none"> <li>Reset the reservation date/time for the remote update.</li> </ul>
65	Reception fails due to the status error of the machine at the reserved date/time of the remote firmware update from the network.	<ul style="list-style-type: none"> <li>Update is to be done automatically when the next reception time has elapsed.</li> </ul>
66	Reception failed due to the status error of the machine at the reserved date/time of the package firmware update from the network.	<ul style="list-style-type: none"> <li>Reset the reservation date/time for the remote update.</li> </ul>
67	Acquisition of the latest version information from the Gateway fails at the reserved date/time of the remote firmware update from the network.	<ul style="list-style-type: none"> <li>Check that the network is connected correctly.</li> </ul>

Code	Contents	Solutions
68	Acquisition of the latest version information from the Gateway fails.	<ul style="list-style-type: none"> <li>Check that the network is connected correctly.</li> </ul>
69	Download fails at the reserved date/time of the remote firmware update from the network.	<ul style="list-style-type: none"> <li>Check that the network is connected correctly.</li> </ul>
70	Package firmware download from the network fails.	<ul style="list-style-type: none"> <li>Check that the network is connected correctly.</li> </ul>
71	Network communication error occurs at the reserved date/time of the package firmware update from the network.	<ul style="list-style-type: none"> <li>Check that the network is connected correctly.</li> </ul>
72	The setting of @Remote is invalid at the reserved date/time of the package firmware update from the network.	<ul style="list-style-type: none"> <li>Set the setting of @Remote Service in the Administrator Tools to [Do not Prohibit].</li> </ul>
221	Application installed in the machine cannot be terminated when you update or uninstall the application.	<ul style="list-style-type: none"> <li>If the application runs a job, try update/uninstallation again after the job ends.</li> <li>Turn OFF then ON the main power to try again.</li> </ul>
222	Invalid digital signature	<ul style="list-style-type: none"> <li>Try again with correct data.</li> </ul>
224	Lack of storage capacity	<ul style="list-style-type: none"> <li>Uninstall unnecessary applications.</li> <li>Reduce the number of applications to install.</li> </ul>
228	Update files are not found.	<ul style="list-style-type: none"> <li>Turn OFF then ON the main power to try again.</li> <li>Replace the operation panel.</li> </ul>
229	Incorrect file	<ul style="list-style-type: none"> <li>Try again with correct data.</li> </ul>

Code	Contents	Solutions
230	Incorrect folder structure	<ul style="list-style-type: none"> <li>Try again with correct data.</li> </ul>
231	Hardware related error	<ul style="list-style-type: none"> <li>Turn OFF then ON the main power to try again.</li> <li>Replace the operation panel.</li> </ul>
235	Installation fails because update files are invalid.	<ul style="list-style-type: none"> <li>Try again with correct data.</li> <li>If there is the same application installed in the machine, uninstall and reinstall it. Then try update again.</li> </ul>
236	Unsupported SDK version	<ul style="list-style-type: none"> <li>Make sure that the system in the machine's operation panel supports the target application.</li> </ul>
255	System error	<ul style="list-style-type: none"> <li>Turn OFF then ON the main power to try again.</li> </ul>

 **Note**

- The PDF firmware installed as standard contains a program required to print PS3 data as default. However, this PS3 program is normally disabled.
- The PS3 firmware is a dongle (key) which enables PS3 data printing functions. When the PS3 firmware is installed, the PS3 program in the PDF firmware is enabled. Due to this specification, the self-diagnosis result report shows the ROM part number/software version of the PDF firmware contained in the PS3 program.

## 4.4 UPDATING JAVAVM

### 4.4.1 CREATING AN SD CARD FOR UPDATING

1. Download the update modules from Firmware Download Center. As one of the model modules, "Java VM v12 UpdateTool" is available for download. (The version differs depending on the model.)
2. Unzip the downloaded file. Copy the whole "sdk" folder to the root of the SD card directly below.

#### Note

- When unzipping the downloaded file, two subfolders ("update" and "sdk") exist in the "sdk" folder. Rather than just copying the subfolder "sdk", copy the whole folder "sdk".

### *Updating Procedure*

#### CAUTION

- SD card can be inserted with the machine power off.
  - During the updating process, do not turn off the power.
  - If you turn off the power during the updating, the machine performance is not guaranteed. (There is a possibility that an SC and boot failure occurs.)
  - If you accidentally turn off the power during the updating, retry the updating procedure from the beginning. (If the update fails again, you will need to replace the controller board.)
1. If the boot priority application is set to the ESA application, switch to the copy of the boot priority application is set to the ESA application, switch to the home application. ([User Tools]- [Screen Features]- [Screen Device Settings]- [Function Priority]- [Home])
  2. Take a note of the current Heap size. ([User Tools] – [Machine Features] – [Extended Feature Settings] – [Extended Feature Settings] – [Administrator Tools] – [Heap/Stack Size Settings])  
The Heap size setting is changed to the initial setting when updating.
  3. Turn OFF the main power.
  4. Insert the SD card for update into the service slot.
  5. Turn ON the main power.
  6. After booting Java VM, update of the application is started. "Updating SDK/J" appears in the system message of the touch panel display after 1 minute. (Estimated time: about 2.5 minutes)
  7. After completing the update and starting the Java VM, "Update SDK / J done SUCCESS" appear in the System message of the touch panel display. After turning off the power, remove the SD card from the slot.

When you fail to update, "Update SDK/J done FAIL" is displayed. You can confirm the cause of the error message below.

8. Turn ON the main power.
9. Reconfigure the Heap size. ([User Tools] – [Machine Features] – [Extended Feature Settings] – [Extended Feature Settings]-[Administrator Tools]-[Heap/Stack Size Settings]) in reference to STEP2.

**Note**

- If you have not done STEP2, see the manual for the ESA application to know what value to set for the heap size.

10. Return to the previous setting for the boot priority application.

**List of Error Messages**

Update results are output as a text file on the SD card called "sdkjversionup.log" in the "¥sdk ¥update" folder.

Result	File contents	Description of the output
Success	script file = /mnt/sd0/sdk/update/bootscrip 2012/08/22 17:57:47 start 2012/08/22 17:59:47 end SUCCESS	Boot script path Boot scripts processing start time End time boot script processing, the results
Failure	script file = /mnt/sd0/sdk/update/bootscrip 2012/08/22 17:57:47 start XXXX Error 2012/08/22 17:57:57 end FAIL	Boot script path Boot scripts processing start time Error message (Possibly multiple) End time boot script processing, the results



Error Message	Cause	Remedy
PIECEMARK Error,machine=XXXXX	Applied the wrong updating tool (Using the updating tool of a different model)	Use the correct updating tool for this model.
pasePut() - error : The file of the copy origin is not found Put Error!	Inadequacy with the SD card for updating (Files are missing in the updating tool)	Re-create the SD card for updating.
paseCopy() - error : The file of the copy origin is not found. Copy Error!	Inadequacy SD card for updating (Files in the updating tool are missing)	Inadequacy SD card for updating (Files in the updating tool are missing)
[file name: XX] error,No space left on device pasePut() - error : The destination directory cannot be made. pasePut() - error : fileCopy Error. Put Error!	Writing destination is full. (The NAND flash memory on the controller board is full.)	Uninstall the unnecessary SDK applications. If you can not uninstall it, implement escalation, stating the "model name, application configuration, SMC sheet (SP5-990-006/024/025), and error file."
[file name: XX] error,No space left on device paseCopy() - error : The destination directory cannot be made. paseCopy() - error : fileCopy Error. Copy Error!	Writing destination is full. (The NAND flash memory on the controller board is full.)	Uninstall the unnecessary SDK applications. If you can not uninstall it, implement escalation stating the "model name, application configuration, SMC sheet (SP5-990-006/024/025), and error file."
Put Error! *1	Error, not normally expected to occur	If you cannot uninstall it, implement escalation
Copy Error! *1		

Error Message	Cause	Remedy
Delete Error!		stating the "model name, application configuration, SMC sheet (SP5-990-006/024/025), and error file." *1 Without the foregoing error message, only "Put Error / Copy Error" will be displayed
[XXXXXX] is an unsupported command.		
Version Error		

## 4.5 NVRAM DATA UPLOAD/DOWNLOAD

### 4.5.1 UPLOADING CONTENT OF NVRAM TO AN SD CARD

Do the following procedure to upload SP code settings from NVRAM to an SD card.

**Note**

- This data should always be uploaded to an SD card before the NVRAM is replaced.
- Make sure that the write protection of an SD card is unlocked

1. Do SP5-990-001 (SMC Print) before turning OFF the main power. You will need a record of the NVRAM settings if the upload fails.
2. Turn OFF the main power.
3. Remove the SD card slot cover [A].

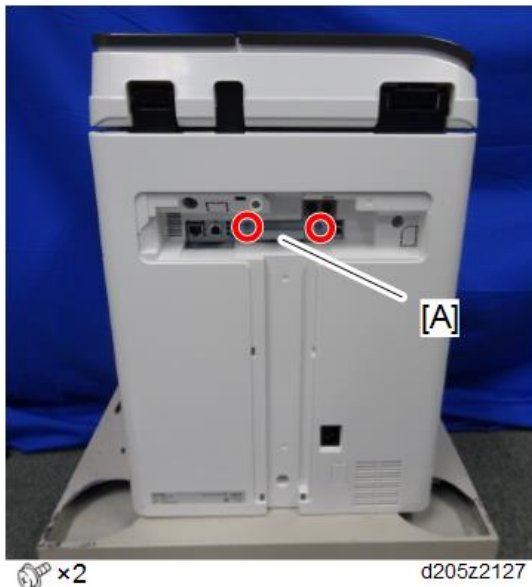

4. Insert the SD card into SD slot 2 [B].

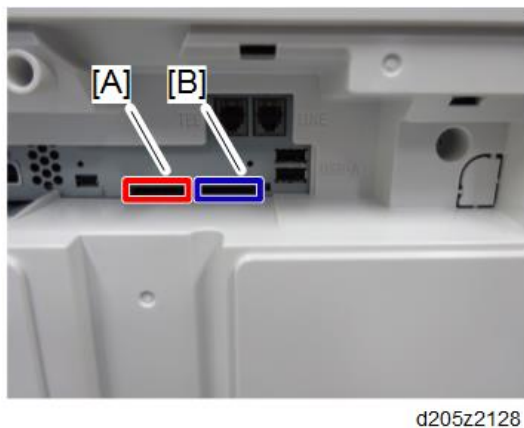

5. Turn ON the main power.
6. Execute SP5-824-001 (NVRAM Data Upload) and then press the “Execute” key.
7. The following files are copied to an NVRAM folder on the SD card when the upload

**procedure is finished.**

The file is saved to the path and the following filename:

**NVRAM¥<serial number>.NV**

Here is an example with Serial Number “K5000017114”:

**NVRAM¥K5000017114.NV**

- 8. In order to prevent an error during the download, be sure to mark the SD card that holds the uploaded data with the number of the machine from which the data was uploaded.**

 **Note**

- You can upload NVRAM data from more than one machine to the same SD card.

## 4.5.2 DOWNLOADING AN SD CARD TO NVRAM

Do the following procedure to download SP data from an SD card to the NVRAM in the machine.

- The NVRAM data download may fail if the SD card with the NVRAM data is damaged, or if the connection between the controller and BiCU is defective.
  - Do the download procedure again if the download fails.
  - Do the following procedure if the second attempt fails:
  - Enter the NVRAM data manually using the SMC print you created before uploading the NVRAM data.
- 1. Turn OFF the main power.**
  - 2. Remove the SD card slot cover.**
  - 3. Insert the SD card with the NVRAM data into SD slot 2.**
  - 4. Turn ON the main power.**
  - 5. Do SP5-825-001 (NVRAM Data Download) and press the “Execute” key.**

 **Note**

- The serial number of the file on the SD card must match the serial number of the machine for the NVRAM data to download successfully. The download fails if the serial numbers do not match.

This procedure does not download the following data to the NVRAM:

- Total Count
- C/O, P/O Count

## 4.6 UP/SP DATA IMPORT/EXPORT

### 4.6.1 OVERVIEW

#### *Import/export conditions*

Import/export is possible between devices only if their model type, region of use, and the following device configurations match.

- Input Tray
- Output Tray
- ARDF
- Whether or not equipped with a hard disk
- Whether or not equipped with a finisher and the type of finisher

### 4.6.2 UP DATA IMPORT/EXPORT

#### *Data that can be imported and exported*

- Copier / Document Server Features
- Printer Features
- Scanner Features
- Facsimile Features
- Browser Features
- Extended Feature Settings
- Program (Document Server)
- Program (Copier)
- Program (Scanner)
- Web Image Monitor Setting
- Web Service Settings
- System Settings

### ***Data that cannot be imported or exported***

- Some System Settings \*1 \*2
  - \*1 The setting for the date, settings that require the device certificate, and settings that need to be adjusted for each machine (for example, image adjustment settings) cannot be imported or exported.
  - \*2 Settings only for executing functions and settings only for viewing cannot be imported or exported.
- Extended Feature Settings
- Address book
- Programs (fax function)
- Programs (printer function)
- User stamp in Copier / Document Server Features
- Settings that can be specified via telnet
- @Remote-related data
- Counters
- EFI printer unit settings
- Settings that can only be specified via Web Image Monitor or Web Service (for example, Bonjour, SSDP setting)

### ***Exporting Device Information***

This can be exported / imported by an administrator with all privileges.

When exporting SP device information from the control panel, the data is saved on an SD card.

1. **Insert an SD card into the media slot on the side of the control panel.**
2. **Log in from the control panel as an administrator with all privileges.**
3. **Press [System Settings].**
4. **Press [Administrator Tools].**
5. **Press [Next] four times.**
6. **Press [Device Setting Information: Export (Memory Storage Device)].**

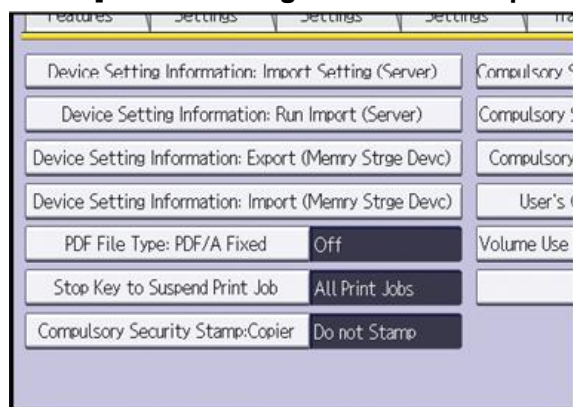

w\_d1825501



## 7. Set the export conditions.

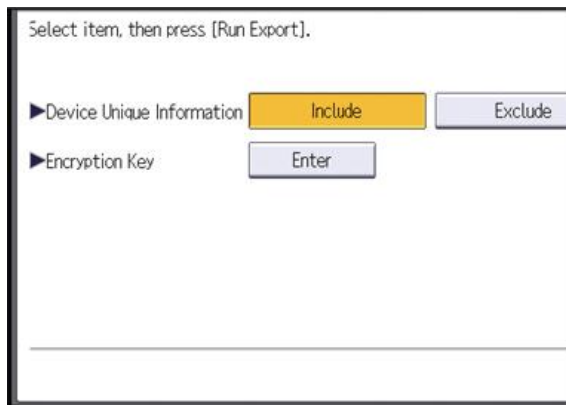

w\_d1825502

- Specify whether to [Include] or [Exclude] the "Device Unique Information". "Device Unique Information" includes the IP address, host name, fax number, etc.
- Specify an encryption key.

## 8. Press [Run Export].

## 9. Press [OK].

## 10. Press [Exit].

## 11. Log out.

### ⓘ Note

- If data export fails, the details of the error can be viewed in the log.
- When device Information is periodically imported, it is necessary to create the device setting information file with special software and store it on the web server.

## ***Importing Device Information***

This can be exported / imported by an administrator with all privileges.

Import device information saved on an SD card.

1. **Insert an SD card into the media slot on the side of the control panel.**
2. **Log in from the control panel as an administrator with all privileges.**
3. **Press [System Settings].**
4. **Press [Administrator Tools].**
5. **Press [Next] four times.**
6. **Press [Device Setting Information: Import (Memory Storage Device)].**
7. **Configure the import conditions.**

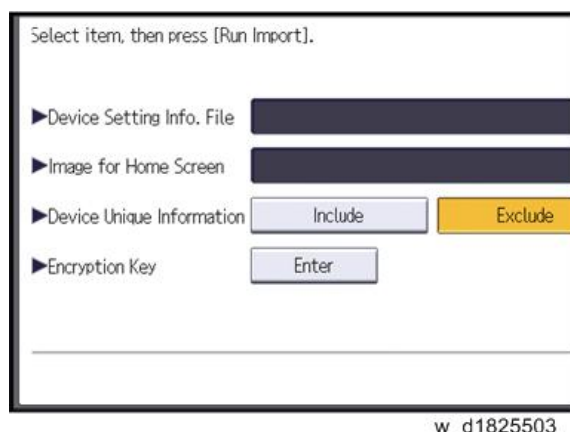

- Press [Select] of the "Device Setting Info. File" to select the file(s) to import.
- When inserting a file into a home screen, press [Select] for the Image for Home screen and select the file. You cannot use this setting when using the Smart Operation Panel.
- Specify whether to [Include] or [Exclude] the "Device Unique Information". "Device Unique Information" includes the IP address, host name, fax number, etc.
- Enter the encryption key that was specified when the file was exported.

8. Press [Run Import].

9. Press [OK].

10. Press [Exit].

The machine restarts.

**Note**

- If data export fails, the details of the error can be viewed in the log.

### 4.6.3 SP DATA IMPORT/EXPORT

#### *Data that can be imported and exported*

- System SP
- Printer SP
- Fax SP
- Scanner SP

#### *Exporting Device Information*

When exporting SP device information from the control panel, the data is saved on an SD card.

1. Insert an SD card into the media slot on the side of the control panel.
2. Enter SP mode.
3. Press SP5-749-001 (Import/Export: Export)
4. Select "Target" SP settings (System/Printer/Fax/Scanner) to be exported.
5. Select "Option" settings (Unique/Secret).

Item	Specification	Note
Unique	Unique information of the machine is included in the exported file if you select "Unique" setting.	<p><b>Unique information that can be updated</b></p> <p>#1. Items that are to be used to identify the machine. Example: Network Information/ Host name / Information related to fax number /Mail address assigned to the machine</p> <p>#2. Items for specifying the options equipped on the machine. Example: Lot number for developer</p> <p><b>Unique information that cannot be updated</b></p> <p>#1. Items that may cause a problem if imported Example: Serial number / Information related to @Remote</p> <p>#2. Items for managing the history of the machine Example: Time and date / Counter information / Installation date</p> <p>#3. Setting values for the Engine</p>
Secret	Secret information is exported if you select "Secret" setting.	<p><b>Secret information</b></p> <p>#1. Data that cannot be exported without being encrypted. (Exported data is encrypted.) Example: Password / Encryption key / PIN code</p> <p>#2. Confidential information for the customer Example: User name / User ID / Department code / Mail address / <b>Phone number</b></p> <p>#3. Personal information Example: Document name / Image data</p> <p>#4. Sensitive information for the customer Example: MAC address / Network parameters</p>

\* The IP address is exported when both 'Unique' and 'Secret' are selected.

#### 6. Select “Crpt config” setting (Encryption).

Encryption	Select whether to encrypt or not when exporting. If you push the "Encryption" key, you can export secret information.	If the encryption function is used, setting of an encryption key is required by direct input. <ul style="list-style-type: none"> <li>▪ Type the arbitrary password using the soft keyboard</li> <li>▪ Can enter up to 32 characters</li> </ul>
------------	--	--

7. Press [Execute].

8. Press [OK].

 Note

- If data export fails, the details of the error can be viewed in the log.

### ***Importing Device Information***

Import device information saved on an SD card.

1. Insert an SD card into the media slot on the side of the control panel.
2. Enter SP mode.
3. Press SP5-749-101(Import/Export: Import)
4. Select a unique setting.
5. Press [Encryption Key], if the encryption key was created when the file was exported.
6. Select an encryption setting.

Unique	If you want to apply the unique information to the target machine, select the "Unique" key.	Refer to the above information.
Encryption	If an encrypted file is selected as the import file, this setting is required.	

7. Press [Execute].

8. Press [OK].

 Note

- If data export fails, the details of the error can be viewed in the log.

## 4.6.4 POSSIBLE SOLUTIONS FOR IMPORT/EXPORT PROBLEMS

The access log file is created when export/import is executed. The file is stored in the same location as the exported device setting information file.

If an error occurs, check the log's result code in the access log file first. Values other than 0 indicate that an error occurred.

The result code will appear in the circled area illustrated below.

- Example of a log file

```
*1,0,0*
*ExecType*,*Date*,*SerialNo*,*PnP*,*Model*,*Destinaion*,*IP*,*Host*,*Storage*,*FileNam
e*,*FileID*,*TotalItem*,*NumOfOkItem*,*ResultCode*,*ResultName*,*Identifier*
*IMPORT*
*2012-07-05T15:29:16+09:00*
*3C35-7M0014*
*Brand Name*
*Product Name*
*0*
*10*
*10.250.155.125*
*RNP00267332582D*
*SD*
*201207051519563C35-710220.csv*
*201207051519563C35-710220*
* 0*
* 2*
*Invalid ID REQUEST*
*TargetID*,*ModuleID*,*PrefID*,*Item*,*NgCode*,*NgName*
```

w\_d1825500

If you cannot solve the problem or do not know how to solve it after checking the code, note down the error log entry, then contact your supervisor.

Result Code	Cause	Solutions
2 (INVALID REQUEST)	A file import was attempted between different models or machines with different device configurations.	Import files exported from the same model with the same device configurations.
4 (INVALID OUTPUT DIR)	Failed to write the device information to the destination device.	Check whether the destination device is operating normally.
7( MODULE ERROR)	An unexpected error occurred during import or export.	Turn OFF then ON the main power, and then try the operation again. If the error persists, contact your supervisor.

Result Code	Cause	Solutions
8 (DISK FULL)	The available storage space on the external medium is insufficient.	Execute the operation again after making sure there is enough storage space.
9 (DEVICE ERROR)	Failed to write or read the log file.	Check whether the path to the folder for storing the file or the folder in which the file is stored is missing.
10 (LOG ERROR)	The hard disk is faulty.	Contact your supervisor.
20 (PART FAILED)	Failed to import some settings.	<p>The reason for the failure is logged in "NgCode". Check the code.</p> <p><b>Reason for the Error (Ng-Name)</b></p> <p>2. INVALID VALUE The specified value exceeds the allowable range.</p> <p>3. PERMISSION ERROR The permission to edit the setting is missing.</p> <p>4. NOT EXIST The setting does not exist in the system.</p> <p>5. INTERLOCK ERROR The setting cannot be changed because of the system status or interlocking with other specified settings.</p> <p>6. OTHER ERROR The setting cannot be changed for some other reason.</p>
21 (INVALID FILE)	Failed to import the file because it is in the wrong format in the external medium.	<p>Check whether the file format is correct.</p> <p>The import file should be a CSV file.</p>
22 (INVALID KEY)	The encryption key is not valid.	Use the correct encryption key.



**Note**

- When exporting device information from the control panel, the data can be saved only on an SD card.
- The file format for exports is CSV.

## 4.7 ADDRESS BOOK EXPORT/IMPORT

### 4.7.1 EXPORT

Backup address book information on SD card formatted with the specified software.

1. Turn OFF the main power.
2. Remove the T-shaped cover.
3. Remove the SD slot cover [A].

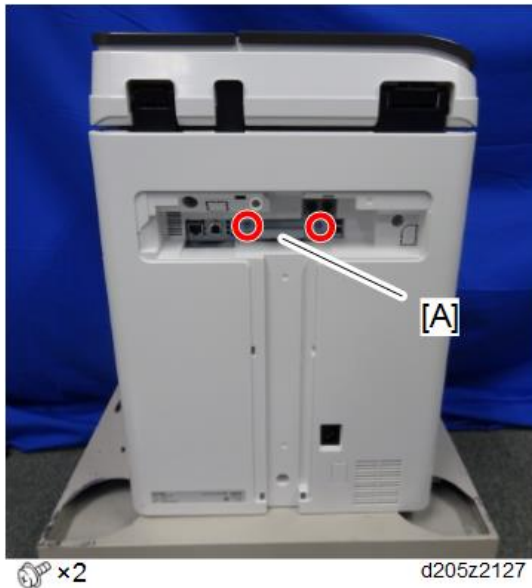

4. Insert the SD card in the service slot [B].

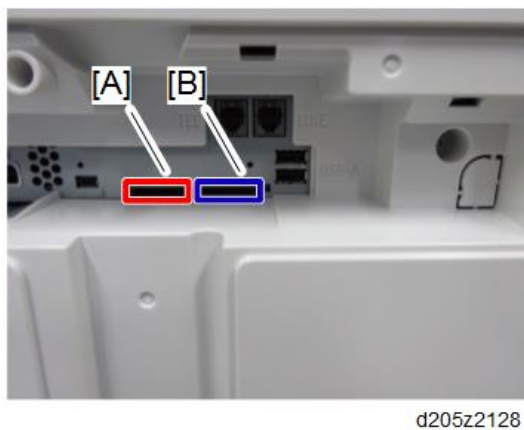

5. Turn ON the main power.
6. Execute SP5-846-051 full address book backup.
7. Turn OFF the main power.
8. Remove the SD card.
9. Attach the SD slot cover to the original position.

**Note**

- When local user information to be uploaded is not contained in the SD card, an execute malfunction is displayed. It cannot be used in the write-protect state.
- Since the address book is the customer's information, take care about handling it, and never bring it back.

## 4.7.2 IMPORT

1. Turn OFF the main power.
2. Remove the SD slot cover of the controller unit.
3. Set the SD card in the service slot.
4. Turn ON the main power.
5. Execute SP5-846-052 (address book information restore).
6. Turn OFF the main power.
7. Remove the SD card.
8. Attach the SD slot cover to the original position.
9. Turn ON the main power, and check that the address book has been restored.

**Note**

- User code counter information is initialized.
- Administrator and supervisor information is not backed up. Also, it is not erased during restore.
- If a download file does not exist, or if erasure is complete, execution malfunction is displayed.

### 4.7.3 SPECIFICATION

The information which can be exported /imported is the following items.

- Entry information
- User code information
- E-mail information
- Protection code information
- Fax information
- Fax additional information
- Group information
- Title information
- Title position information
- Folder information
- SMTP attestation
- Local authorization
- Folder authorization information
- Account ACL information
- New document initial ACL information
- LDAP authorization information

## 4.8 RFU UPDATING THE FIRMWARE

In this machine, software can be updated by remote control using @Remote.

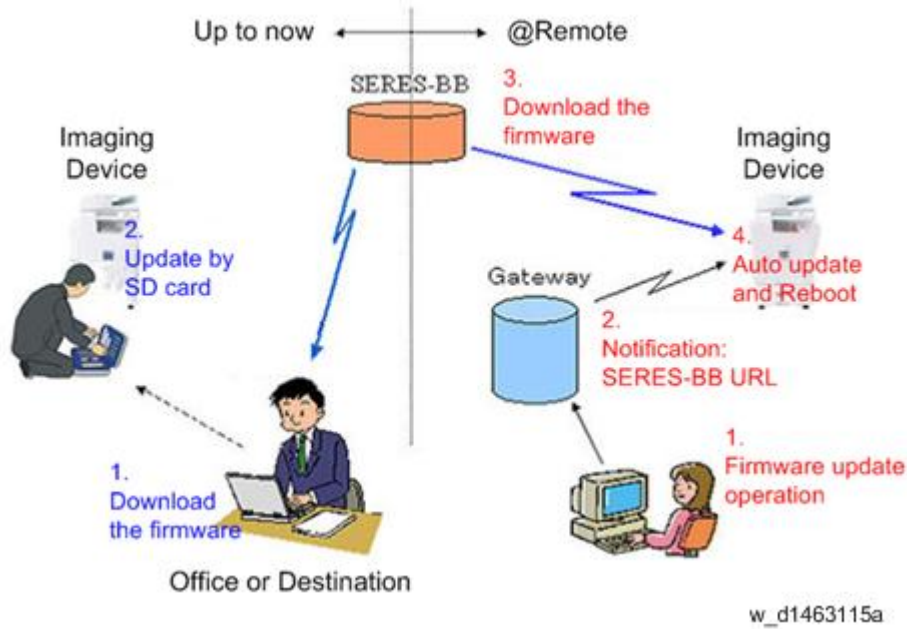

### 4.8.1 RFU PERFORMABLE CONDITION

RFU is performable for a device which meets the following conditions.

1. The customer consents to the use of RFU.
2. The device is connected to a network via TCP/IP for @Remote.

## 4.9 PACKAGE FIRMWARE UPDATE

### ⚠ CAUTION

- The HDD unit must be installed on the machine to enable the SFU or the package firmware update via SD card.

### 4.9.1 OVERVIEW

Each firmware module (such as System/Copy, Engine, etc) used to be updated individually. However, an all-inclusive firmware package (package\_ALL) is now available.

There are two ways to update using the firmware package.

- Package Firmware Update via a network: SFU (Smart Firmware Update)
- Package Firmware Update with an SD card

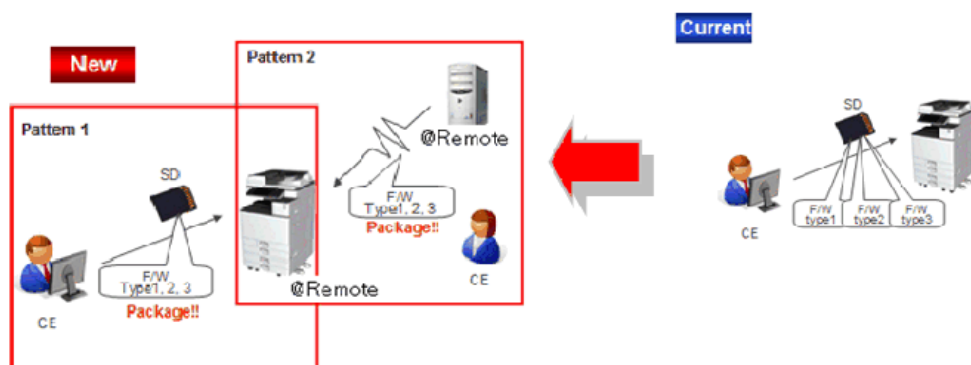

w\_d176f2130

### Package Firmware Update via a network: SFU (Smart Firmware Update)

- There are two methods for SFU.
  - Immediate Update: To update the firmware when visiting
  - Update at the next visit: To set the date and time for downloading. The firmware will be automatically downloaded beforehand and updated at the following visit.
- "Update at the next visit" is recommended since firmware download may take some minutes due to the network condition.

#### ⓘ Note

- SFU requires the connection to @Remote via a device which has the embedded @Remote communicating function. When a machine is connected to @Remote via an intermediate device (RC Gate), the SFU function is disabled.

### Package Firmware Update via an SD Card

Package firmware update can also be performed using the conventional SD card method by writing the package firmware directly to the SD card.

### Types of firmware update files, supported update methods:



	SFU	SD	RFU
Individual firmware	N/A	Available	Available
Package firmware	Available	Available	N/A

## 4.9.2 IMMEDIATE UPDATE

Enter the [Firmware Update] menu in the SP mode and update the package firmware.

**Note**

- The [Firmware Update] button will appear even when a machine is connected to @Remote with a device which does not have an embedded @Remote communicating function.
- If an error code is displayed, refer to Error screens during updating (Error Screens During Updating).

1. Enter the SP mode.
2. Press [Firmware Update].

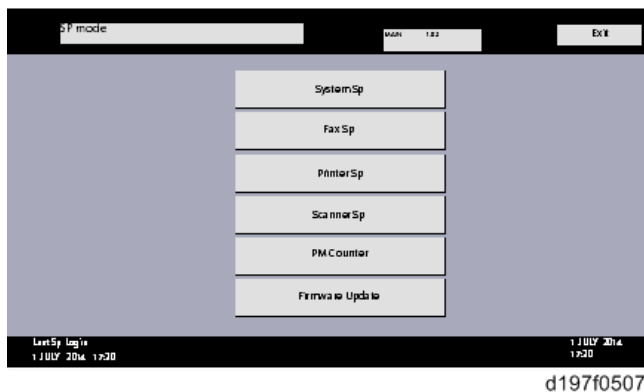

3. Press [Update].

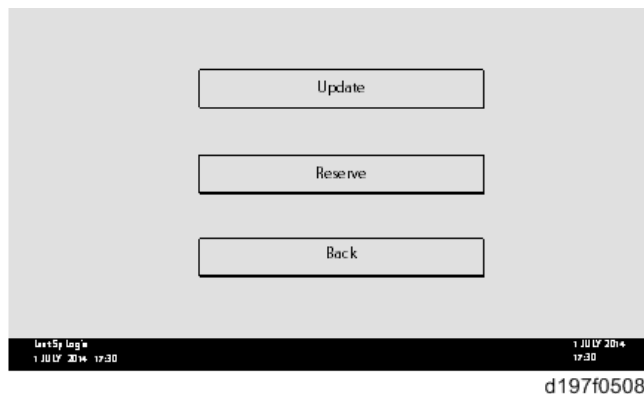

4. Press [Execute Update].

## Package Firmware Update

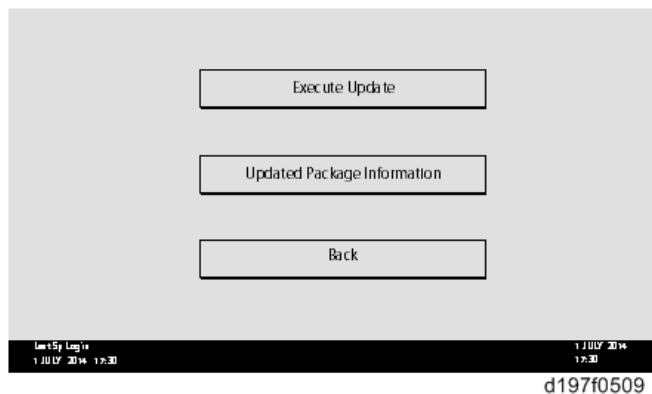

### 5. Press [YES].

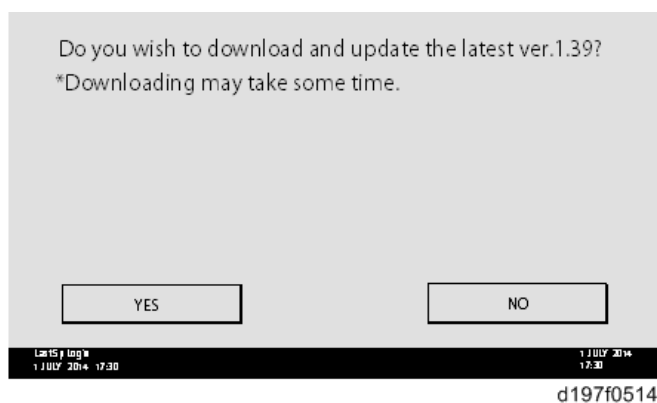

### 6. The following display will be displayed.

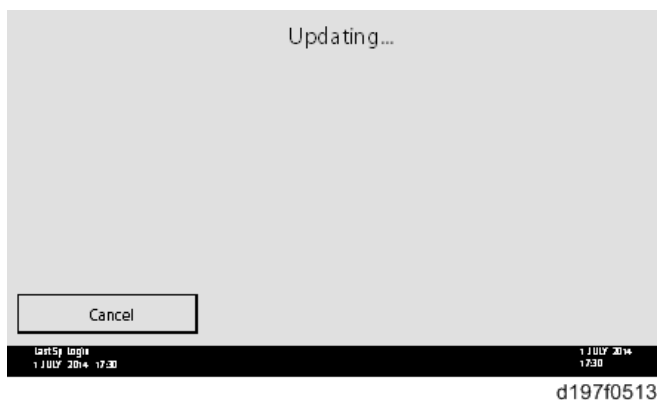

#### Note

- If the error code E66, which indicates that the download of the firmware has failed, is displayed, implement this procedure from step 1.
- Update will be started automatically after the download is finished.
- When the machine is in the update mode, the automatic update is suspended if a print job is implemented. After the print job is finished, Press [YES] on the display shown with the following picture to restart updating.

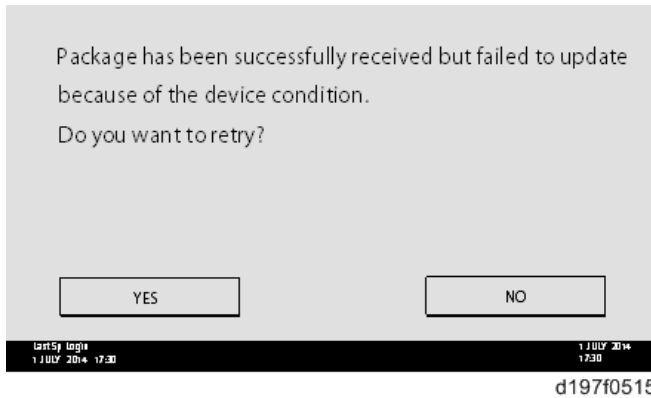

**7. [Update done] is displayed.**

- The machine will automatically reboot itself.

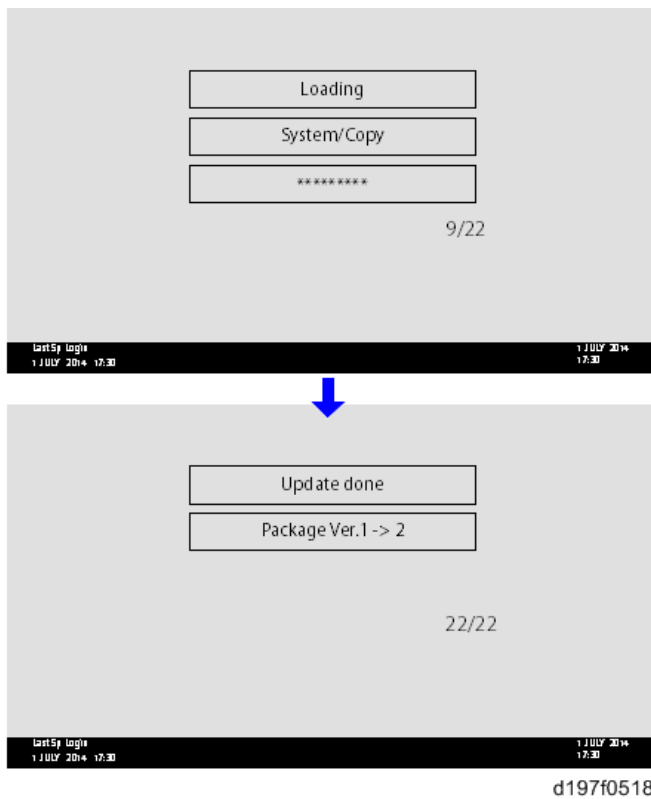

System Maintenance

**Note**

- The figures at the lower right of the display indicate “Number of updated items/ All items to be updated”.

### 4.9.3 UPDATE AT THE NEXT VISIT (RESERVE)

It is possible to set the machine to download the package firmware which is necessary for SFU in advance, and then perform the actual installation at the next service visit. This saves waiting time for the firmware to download at the service visit.

#### ***How to Set the Machine to Download Firmware Later (RESERVE)***

Enter the [Firmware Update] menu in the SP mode and update the package firmware.

**Note**

- The [Firmware Update] button will appear even when a machine is connected to @Remote with a device which does not have an embedded @Remote communicating function. If an error code is displayed, refer to Error Screens During Updating.

1. Enter the SP mode.
2. Press [Firmware Update].

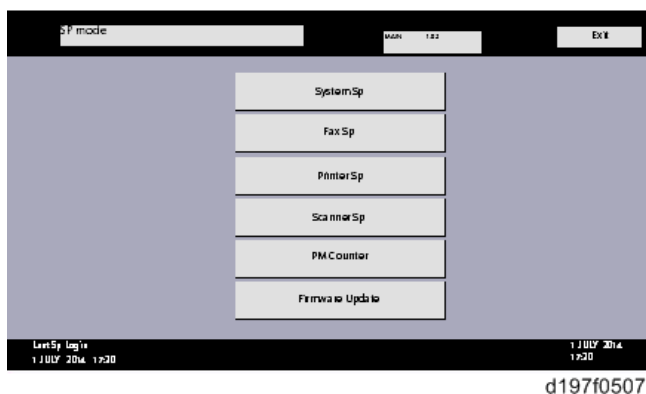

3. Press [Reserve].

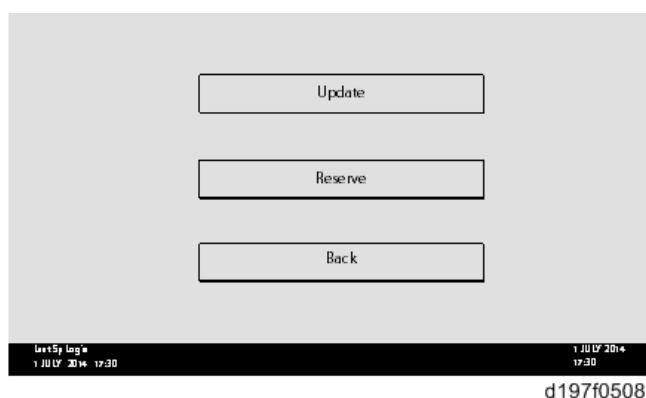

4. Press [Reservation setting].

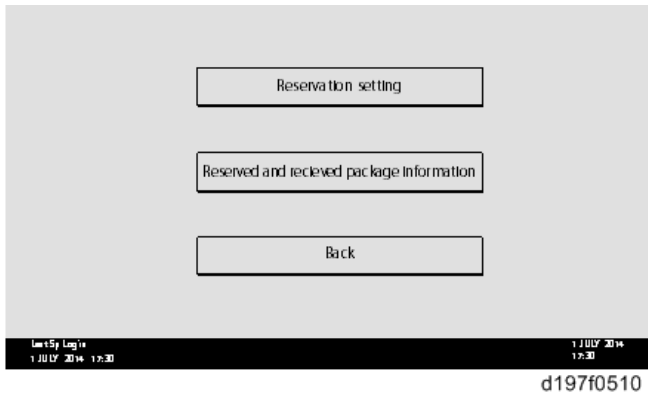

d197f0510

**5. Enter the dates and times of next visit and start of receiving data.**

- "Next time to visit this customer": The package firmware will be automatically downloaded by this time/date.
- "When to receive? (1-7)": The download of the package firmware will begin this number of days before the next visit.

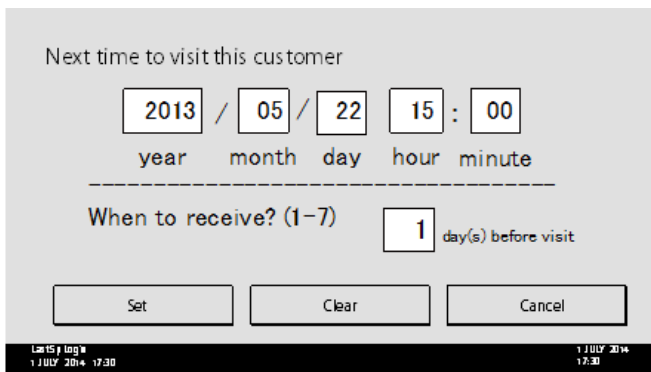

d197f0512

**Successful Download**

In the two diagrams below, the firmware is set to be downloaded by the day before the next scheduled visit. In the first diagram, the download is successful on the first try. In the second diagram, the download fails three times and is successful on the fourth try.

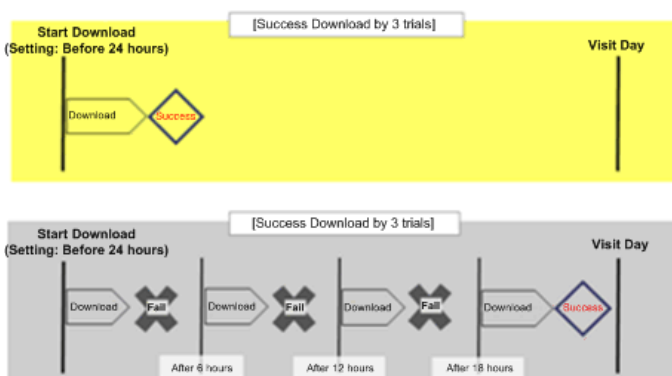

w\_d197f0507

- If the firmware download fails or cannot be completed due to the network settings/condition, no power to the machine, or other reason, the machine will continue retrying every six hours until the scheduled deadline (up to a maximum of four tries). For example, if the download is

## Package Firmware Update

set for the day before the next visit, the machine will attempt the download at 24 hours before the visit, and then continue trying every six hours (max. four tries total).

- The retry is only performed in cases when the firmware download has failed.
- If the machine is in Energy Saver mode when the download is scheduled to begin, the download will be performed in the background and the machine/panel will stay in Energy Saver mode.
- The download will continue uninterrupted even if the customer initiates a print job, copy job, fax receiving or other operation while the download is in progress.
- The download will be terminated if the customer turns OFF the main power while the download is in progress.
- If the download cannot be completed successfully by the time of the next scheduled visit, the machine will stop trying to download the firmware.

### ***How to Check if the Firmware Downloaded with RESERVE***

1. Enter the SP mode.
2. Press [Firmware Update].

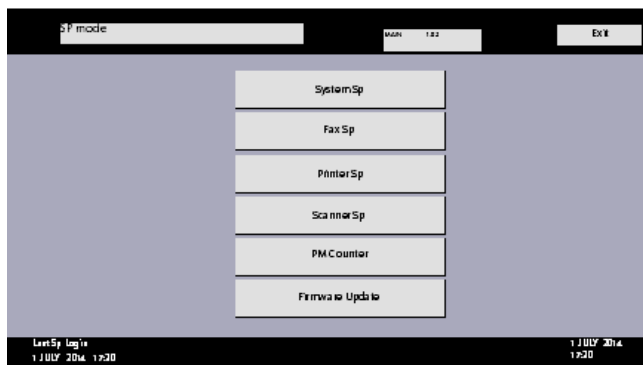

d197f0507

3. Press [Reserve].

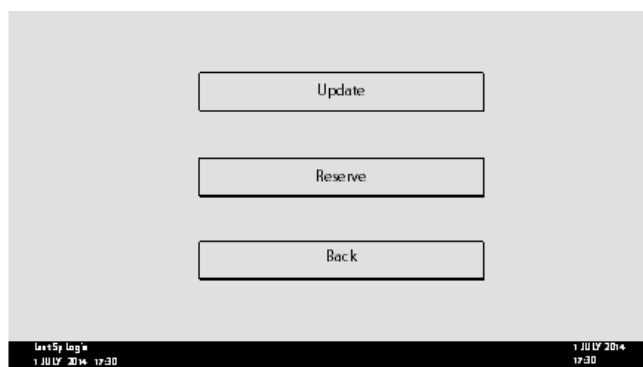

d197f0508

4. Press [Reserve and received package information].



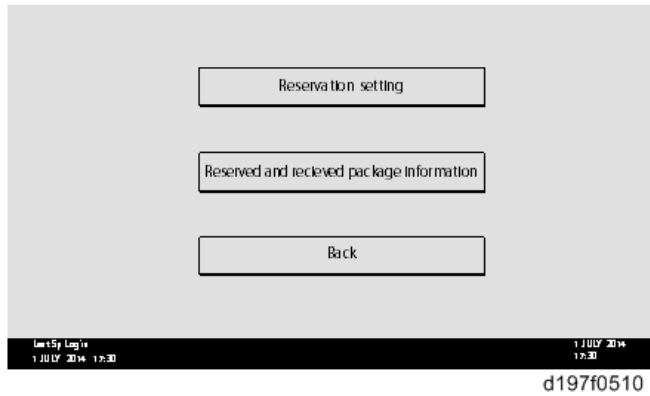

**5. Check the information displayed.**

When the package firmware is downloaded successfully, the details of the download result are displayed as the following picture shows.

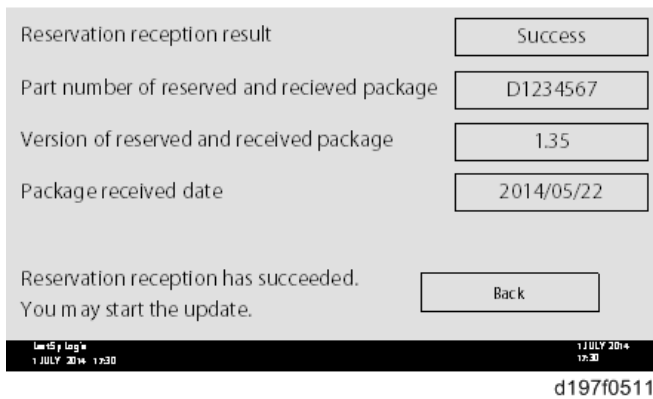

System Maintenance

**Note**

- This information will only be displayed if the reserved firmware has already been downloaded. If not, all the data items are indicated with “-”.

## ***How to Install Firmware Downloaded with RESERVE***

1. Enter the SP mode.
2. Press [Firmware Update].

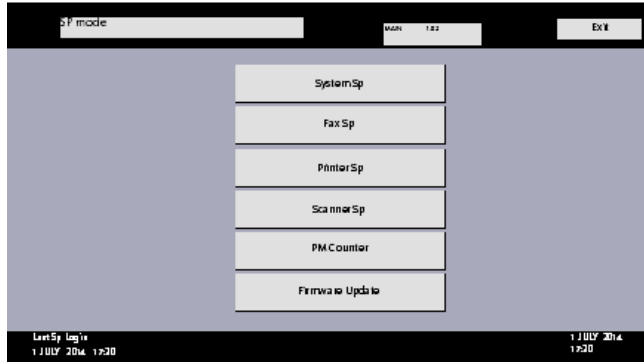

d197f0507

3. Press [Update].

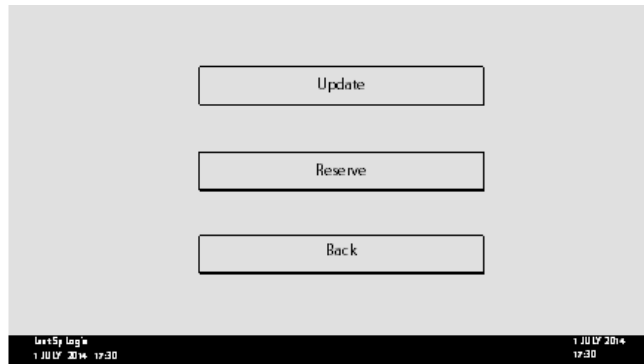

d197f0508

4. Press [Execute Update].

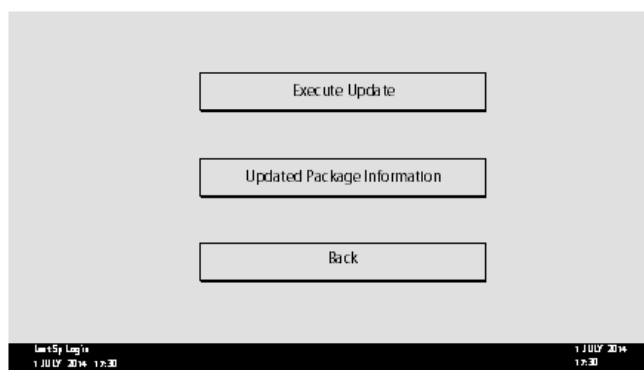

d197f0509

5. Check the version of the received package firmware, and then Press [YES].
  - Update is started.

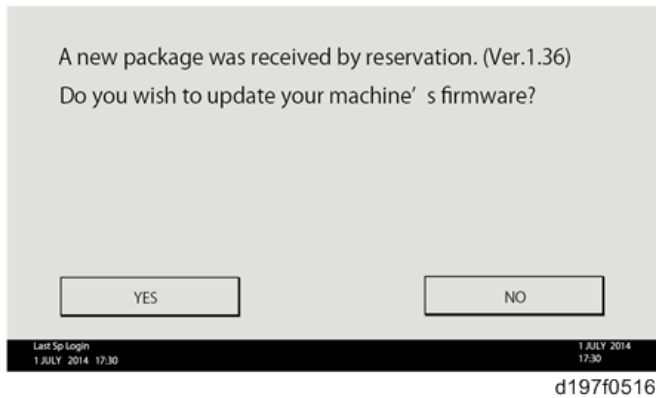

#### ↓ Note

- If the version of the reserved package in the HDD is older than the latest version, the messages shown in the following picture are displayed.

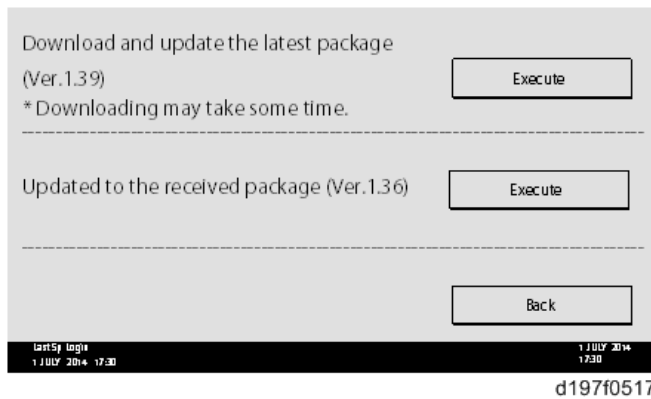

- If you wish to download the latest version, Press [Execute] beside the message “Download and update the latest package.” Then update of the package firmware will be started.
- If you wish to update using the firmware in the HDD (old version), Press [Execute] beside the message “Update to the received package.”

#### 6. [Update done] message is displayed.

- The machine will automatically reboot itself.

## Package Firmware Update

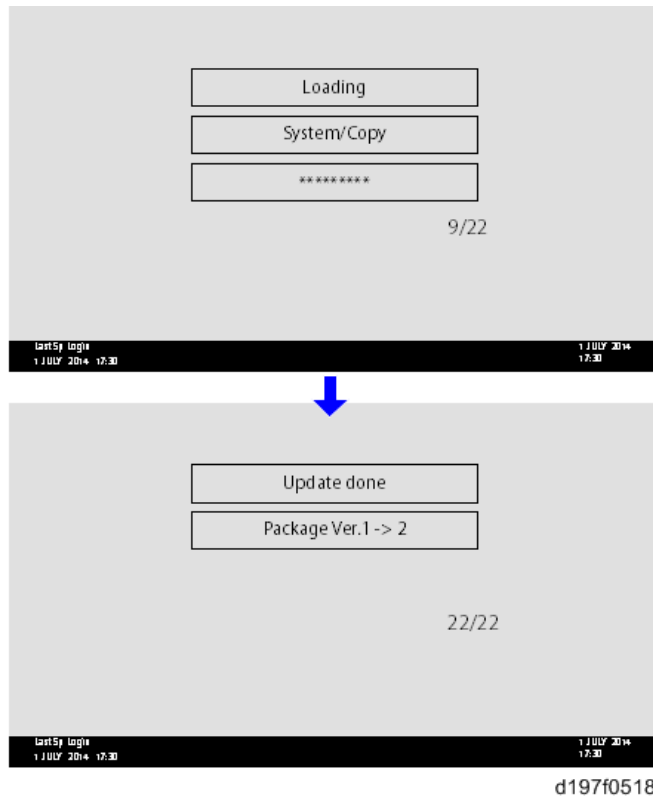

### ↓ Note

- The figures at the lower right of the display indicate “Number of updated items/ All items to be updated”.

## 4.9.4 UPDATE VIA SD CARD

Update with an SD card, which is the conventional method, is available if you write the package firmware to the SD card.

### Note

- If an error code is displayed, refer to Error Screens During Updating.

- Create a new folder in the SD card, and then name it “package”.
- Copy the package firmware (xxxxxxx.pkg) to this folder.

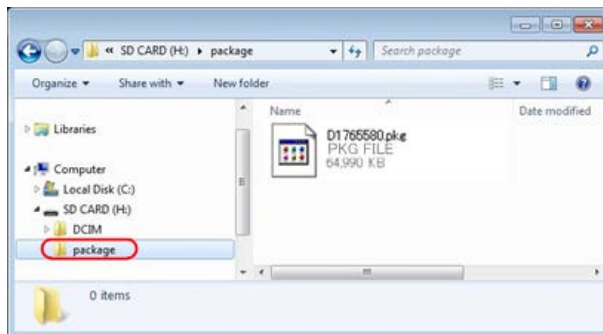

d197f0504

### Important

- If you copy the package firmware into the conventional “romdata” folder, the update will not work.
- Only one version of the package firmware should be copied into the folder. If you copy multiple versions of package firmware to the SD card, the machine will select only one version of the firmware randomly.

- Turn OFF the main power.
- Insert the SD card which contains the package into SD card slot 2 (for service).
- Turn ON the main power
- Press [Update].

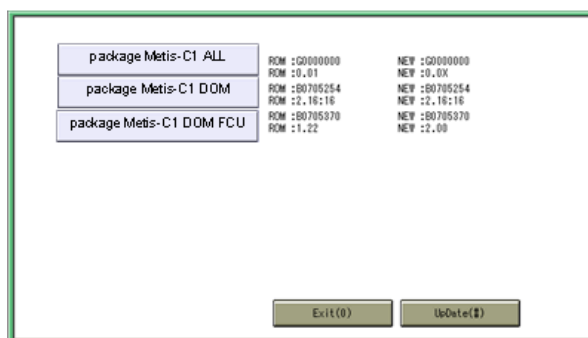

d176f2127

### Note

- When the SD card contains both a firmware package and one or more modules, the following display may show up. Select [Package] and Press [OK] to move to step 4 above.

## Package Firmware Update

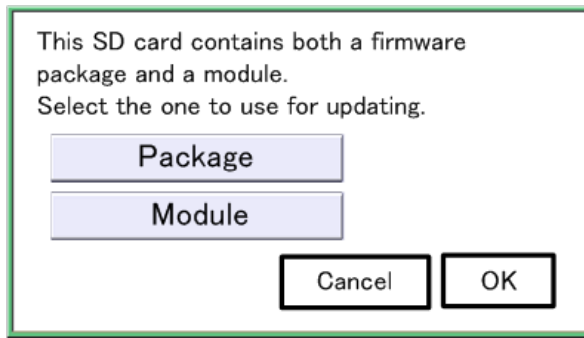

d176f2128

7. Update is started automatically after the package firmware download to the HDD has been completed.
8. When update is completed, "Update done" is displayed.

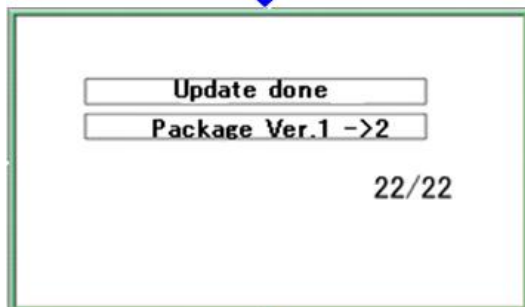
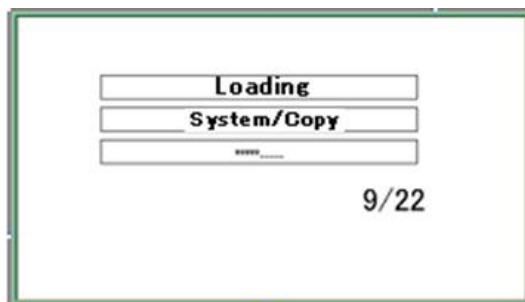

w\_d177z0021a

### ⓘ Note

- The figures at the lower right of the display indicate "Number of updated items/ All items to be updated".

9. Turn OFF the main power.
10. Pull out the SD card from SD card slot 2.
11. Turn ON the main power.



## 4.10 CAPTURING THE DEBUG LOGS

### 4.10.1 OVERVIEW

With this feature, you can save debug logs that are stored in the machine (HDD or operation panel) on an SD card. It allows the Customer Engineer to save and retrieve error information for analysis.

The Capturing Log feature saves debug logs for the following four.

- Controller debug log including operation log
- Engine debug log
- FCU debug log
- Operation panel log

**★ Important**

- In older models, a technician enabled the logging tool after a problem occurred. After that, when the problem had been reproduced, the technician was able to retrieve the debug log.
- However, this new feature saves the debug logs at the time that problems occur. Then you can copy the logs to an SD card.
- You can retrieve the debug logs using a SD card without a network.
- Analysis of the debug log is effective for problems caused by the software. Analysis of the debug log is not valid for the selection of defective parts or problems caused by hardware.

System Maintenance

#### Types of debug logs that can be saved

Type	Storage Timing	Destination (maximum storage capacity)
Controller debug log including operation log	<ul style="list-style-type: none"> <li>▪ Saved at all times</li> </ul>	HDD (4 GB) or SD card connected to the service slot. When the data gets over 4.0 GB, the older data is deleted.

## Capturing the Debug Logs

Type	Storage Timing	Destination (maximum storage capacity)
Engine debug log	<ul style="list-style-type: none"> <li>▪ When an engine SC occurs</li> <li>▪ When paper feeding/output stop by jams</li> <li>▪ When the machine doors are opened during normal operation</li> </ul>	HDD or SD card connected to the service slot (Up to 300 times)
FCU debug log	<ul style="list-style-type: none"> <li>▪ When a specified amount of FCU debug log is stored in the FCU. If fax application is unavailable (e.g. not installed), the machine does not transfer the log.</li> </ul>	HDD or SD card connected to the service slot
Operation panel log	<ul style="list-style-type: none"> <li>▪ When an error related to the operation panel occurs.</li> </ul>	Memory in the operation panel.

### ⬇ Note

- **Debug logs are not saved in the following conditions:**
- While erasing all memory
- While data encryption equipment is installed
- While changing the firmware configuration
- Forced power OFF (accidentally disconnecting the outlet)
- Engine debug log in shutdown
- When the power supply to the HDD is off because of energy saving (engine OFF mode /STR mode)
- When one of the following SC occurs: SC672, SC816, SC819, SC878, SC899, SC859, SC860, SC861, SC863, or SC864

### ⬇ Note

- **Following logs are not saved:**
- Log related to the energy saver mode (Engine-off, suspend-mode, or other cases)
- Network communication log
- Logs related to NRS
- IP-FAX log

- Access log for unauthorized user (guest)
- HTTP session timeout log
- Auto log-out log
- IC card related log
- Authorization for Fax

### ***Security of the Operation Log***

The following operation logs related to security are not saved.

- User ID
- Password
- IP address
- Telephone number
- Encryption key
- Transition to SP mode

## **4.10.2 RETRIEVING THE DEBUG LOGS**

### **★ Important**

- Retrieve debug logs to identify the date of occurrence of the problems and to find details of the problems
- e.g.: At around 8:00 am on March 10, an engine stall occurred. The operation panel does not respond. Turn OFF then ON the main power.
- Analysis of the debug log is effective for problems caused by the software. Analysis of the debug log is not valid for the selection of defective parts or problems caused by hardware

### ***Procedure for Retrieving the Debug Log with SD Card***

1. Insert the SD card into the slot on the side of the operation panel or the service slot.

### **★ Important**

- It is recommended to use either the SD card with 2 GBs (P/N: B6455030) or 8 GBs (P/N: B6455040) provided as service parts. This is because the log data can be acquired much faster than when using commercially available SD cards.
  - Format the SD card by using SD Formatter from Panasonic before copying the logs:
  - [https://www.sdcard.org/downloads/formatter\\_4/](https://www.sdcard.org/downloads/formatter_4/) (The URL is current as of Jan, 2016; and is subject to change)
  - Insert the SD card into the machine's service slot instead of the SD slot on the side of the operation panel.
2. Turn ON the main power.
  3. Enter SP mode.
  4. Specify the date that the problem occurred in SP5-858-101 (Start Date) by setting it to the year-month-day calendar format.

↓ Note

- For example, if a problem occurred on February 1, 2015, the date should be set to "20150201", as shown above.
- Be sure to confirm the date that the problem occurred before obtaining the logs.

**5. Specify the number of days to collect the logs in SP5-858-102 (Days of Tracing).**

↓ Note

- 2 (days) is set by default for MP 305<sup>+</sup>. The value can be changed from 1 to 180.

**6. Execute SP5-858-111 (Acquire All Info & Logs) to copy all of the log types to an SD card.**

↓ Note

- It is possible to obtain the logs separately by the SPs below:
- **SP5-858-111:** All of the information and logs collected by executing the SPs from SP5-858-121 to SP5-858-145, and SMC
- **SP5-858-121:** Configuration page
- **SP5-858-122:** Font page
- **SP5-858-123:** Print setting list
- **SP5-858-124:** Error log
- **SP5-858-131:** Fax information (whether the fax destinations are included or not depends on the setting of SP5-858-103)
- **SP5-858-141:** Controller debug log, engine debug log, operation panel debug log, and SMC
- **SP5-858-142:** Controller debug log
- **SP5-858-143:** Engine debug log
- **SP5-858-144:** Operation panel log
- **SP5-858-145:** FCU debug log
- **SP5-992-001:** SMC

**7. After executing the SP for copying the information and/or logs, a confirmation screen will appear. To proceed obtaining the information and/or logs, press [execute].**

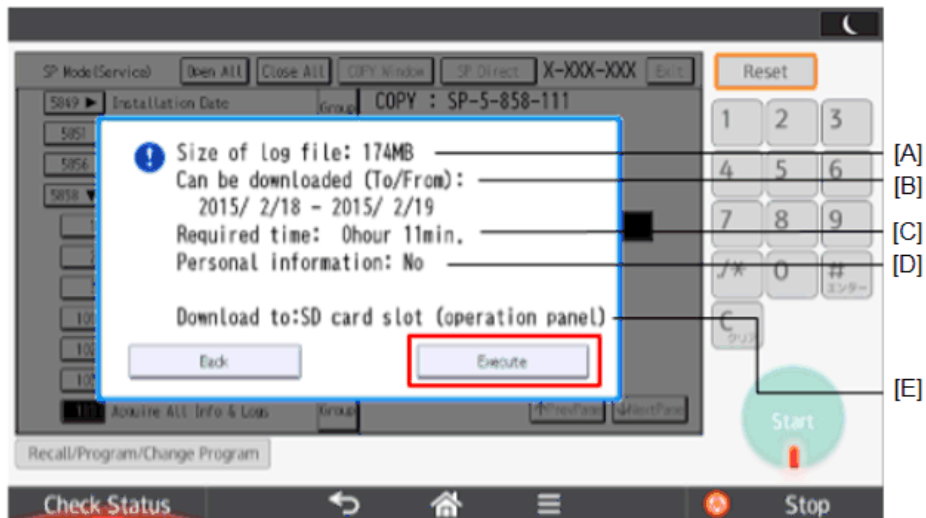

d259z5000

[A]	File size
[B]	Period to copy
[C]	Estimated time to copy
[D]	If [Fax Contacts] is displayed, it means that the fax destinations will be included in the fax information.
[E]	Where the data will be copied.

⬇ Note

- The approximate time it takes to transfer the debug log is as follows. Transfer time may be affected by the type or format of the SD card.
- Controller log (GW debug log): 2 - 20 minutes
- Engine log: 2 minutes
- Operation panel log: 2 - 20 minutes

⬇ Note

- If the estimated time is not calculated due to an error, an error code will be displayed.
- **Error code -1:** Other problem.
- **Error code -2:** No SD card is inserted in the service slot or in the SD slot on the side of the operation panel. Insert an SD card to either of the SD slots.
- **Error code -3:** The SD card is locked. Unlock the SD card as shown below

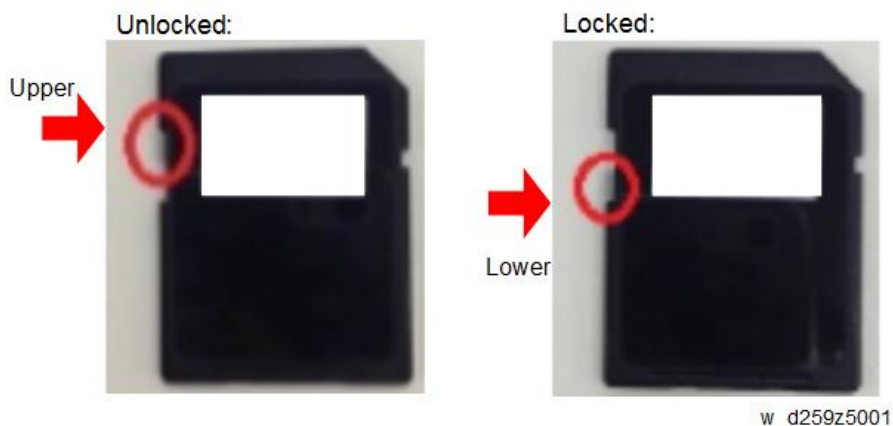

8. Wait for the information and/or logs to be copied to the SD card.
9. After a message stating that the process has completed appears on the operation panel, make sure that the LED light next to the SD slot is not flashing. Then, remove the SD card.

↓ Note

- The process of obtaining logs fails when:
  - the size of the logs to obtain exceeds the amount of space available on the SD card.
  - the SD card is removed while the logs are being copied to it.
  - the SD card is not formatted.

↓ Note

- If 'failed' appears on the touch panel display, turn OFF the main power, and then recover from step 1 again.

↓ Note

- Refer to "Log File List" below to check the location of log files and file name.

### ***Procedure for Retrieving the Debug Log via Web Image Monitor***

1. Access the following URL and login as an administrator:

[http://\[IP address or hostname\]/web/entry/df/websys/direct/getSysinfo.cgi](http://[IP address or hostname]/web/entry/df/websys/direct/getSysinfo.cgi)



2. Specify the date that the problem occurred and the number of days to download the logs. If the fax destinations need to be included in the fax information, set [On] as [Obtain Fax Destination(s) Information]. Then press [Download].



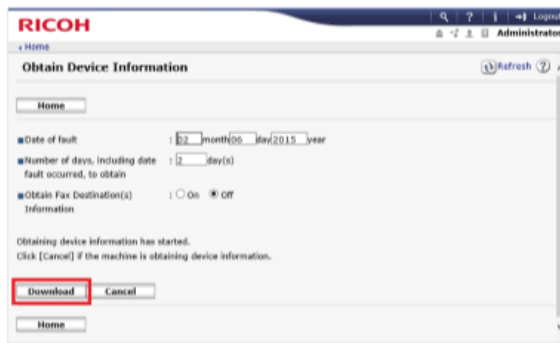

d259z5003

**Note**

- 2 (days) is set by default for MP 305+ The value can be changed from 1 to 180.
- [Obtain Fax Destination(s) Information] is set to [Off] by default.

3. The confirmation screen will appear and the information and/or logs will start being downloaded. To proceed to download the information and/or logs, wait for the open-or-save dialog to appear.

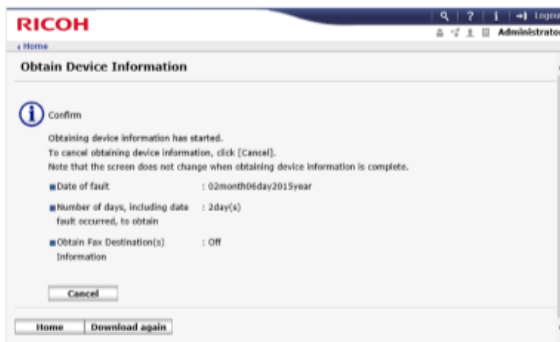

d259z5004

**Note**

- To cancel downloading, press [Cancel].
- To reconfigure some settings, press [Download again].
- Operation panel shows the following while downloading the logs:

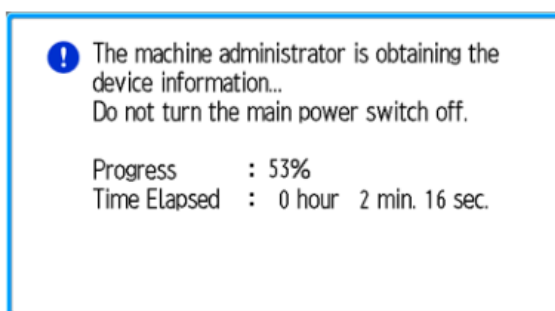

d259z5005

4. After a while, the open-or-save dialog will appear. Specify where to download and save the file.

## Capturing the Debug Logs

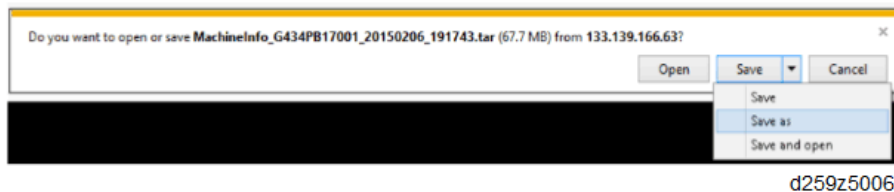

### Note

- Refer to "Log File List" below to check the location of log files and file name.

## Log File List

The logs are saved with the following file path + names.

Controller debug log (mmesg)	/LogTrace/[*the model number]/watching/[yyyymmdd_hhmmss]_[aunique value].gz
Engine debug log	/LogTrace/[*the model number]/engine/[yyyymmdd_hhmmss].gz
Operation panel log	/LogTrace/[*the model number]/opepanel/[yyyymmdd_hhmmss].tar.gz
SMC	/LogTrace/[*the model number]/smc/[*the model number]_[5992xxx]_[yyyymmdd_hhmmss].csv
Configuration page	/LogTrace/[*the model number]/gps/ConfigurationPage/ConfigurationPage_[yyyymmdd_hhmmss].csv
Font page	<ul style="list-style-type: none"> <li>/LogTrace/[*the model number]/gps/FontPage/FontPage_PCL_[the page number]_[yyyymmdd_hhmmss].jpg</li> <li>/LogTrace/[*the model number]/gps/FontPage/FontPage_PDF_[the page number]_[yyyymmdd_hhmmss].jpg</li> <li>/LogTrace/[*the model number]/gps/FontPage/FontPage_PS_[the page number]_[yyyymmdd_hhmmss].jpg</li> </ul>
Print setting list	<ul style="list-style-type: none"> <li>/LogTrace/[*the model number]/gps/PrintSettingList/PrintSettingList_RPGL_[yyyymmdd_hhmmss].txt</li> <li>/LogTrace/[*the model number]/gps/PrintSettingList/PrintSettingList_RTIFFF_[yyyymmdd_hhmmss].csv</li> </ul>
Error log	/LogTrace/[*the model number]/gps/ErrorLog/[yyyymmdd_hhmmss].csv

Fax information	/LogTrace/[*the model number]/faxreport/[yyyymmdd_hhmmss].csv
FCU debug log	/LogTrace/[*the model number]/fcu-log/[yyyymmdd_hhmmss].gz



# TROUBLESHOOTING

REVISION HISTORY		
Page	Date	Added/Updated/New
		None





## 5. TROUBLESHOOTING

### 5.1 SELF-DIAGNOSTIC MODE

#### 5.1.1 SERVICE CALL CODES

##### *Service Call Conditions*

Pattern	Display	How to reset	SC call or SC alarm in customer support system
A	The SC is displayed on the operation panel, and the machine cannot be used (safety-related SC).	Execute CE reset SP mode, and turn OFF then ON the main power. <b>⚠ CAUTION</b> <ul style="list-style-type: none"> <li>When canceling a fusing unit SC, (SC544-00/SC554-00/SC564-00/SC574-00), perform part replacement in accordance with the above procedure.</li> </ul>	Occurrence & alarm count ↓ Immediate alarm
B	When a function is selected, the SC is displayed on the operation panel, and the machine cannot be used (down-time mitigation).	Turn OFF then ON the main power.	Occurrence & alarm count ↓ Power OFF → ON ↓ Alarm count and alarm only if recurrence
C	No display on the operation panel, and use is permitted.	Count only logging.	Occurrence ↓ Logging count & alarm count

Pattern	Display	How to reset	SC call or SC alarm in customer support system
D	The SC is displayed on the operation panel, and the machine cannot be used (machine-error SC).	Turn OFF then ON the main power.	Occurrence & alarm count ↓ Power OFF → ON ↓ Alarm count and alarm only if recurrence

#### ↓ Note

- When an ordinary SC (type D) is generated, an automatic reboot is performed. When an event is reported by the customer support system, even in the event of an ordinary SC, reboot is not performed. During automatic reboot, a confirmation screen is displayed after the reboot.
- When automatic reboot occurs twice continuously, an SC is displayed without rebooting, and logging count is performed. Also, when an SMC print is output, an \* mark is added alongside the SC number for clarity.
- Automatic reboot can be enabled or disabled with SP5-875-001 (SC automatic reboot setting) (default value: ON).

### 5.1.2 SC LOGGING

When an SC is generated, the "total count value when the SC is generated" and the "SC code" are logged. However, if the total count value during the SC is the same as last time, logging is not performed.

Logged data can be checked by outputting an administrative report (SMC print). The SC history is logged up to the last 10 entries, and if there are more than 10 entries, data are progressively deleted starting from the oldest.

### 5.1.3 SC AUTOMATIC REBOOT

When an ordinary SC (pattern D) is generated, automatically reboot is performed. Automatic reboot or reboot by user operation can be set by SP5-875-001 (SC automatic reboot setting out) (default value: 0 "Automatic reboot").

When a type D occurs, automatic reboot is done or the machine display asks the customer if it can reboot. However, when the SC occurs twice in a short time, the machine sends a report to the @Remote server without rebooting. This is because just rebooting may not be a good solution if an SC occurs twice.

When an automatic reboot is performed, a confirmation screen is displayed after reboot. The confirmation screen can be cancelled by pressing the [OK] key (display is not cancelled only when the main power is turned OFF then ON).

#### Screen display during reboot

- Status display on the current screen
    - Post-processing ..... Post-processing during printing, etc.
    - Automatic reboot .... After operation end
- Post-processing
- ■ □ □ □ □ □ □ □ □
- Until automatic reboot
- □ □ □ □ □ □ □ □ □
- Reset key (Reboot key)
- Key to perform reboot
- # Cancel key is not displayed.
- Turn on spanner LED (same as when an SC is generated).

#### Operation during SC reboot

- Timing of SC reboot
 

When @Remote is enabled, and when a NRS alarm\*1 is not generated, the corresponding SC is the object of an automatic reboot.

\*1 NRS alarm: Issued when an ordinary SC (type D) is generated twice while the total counter counts 10 times.
- Time to automatic reboot
 

Reboot is performed 30 seconds after an engine reboot is possible, after the end of post-processing during printing, etc.

At that time, a reboot is performed even if the MFP is operating. The engine does not start process control when a reboot is possible.
- Automatic reboot
 

See the flowchart below.

# Self-Diagnostic Mode

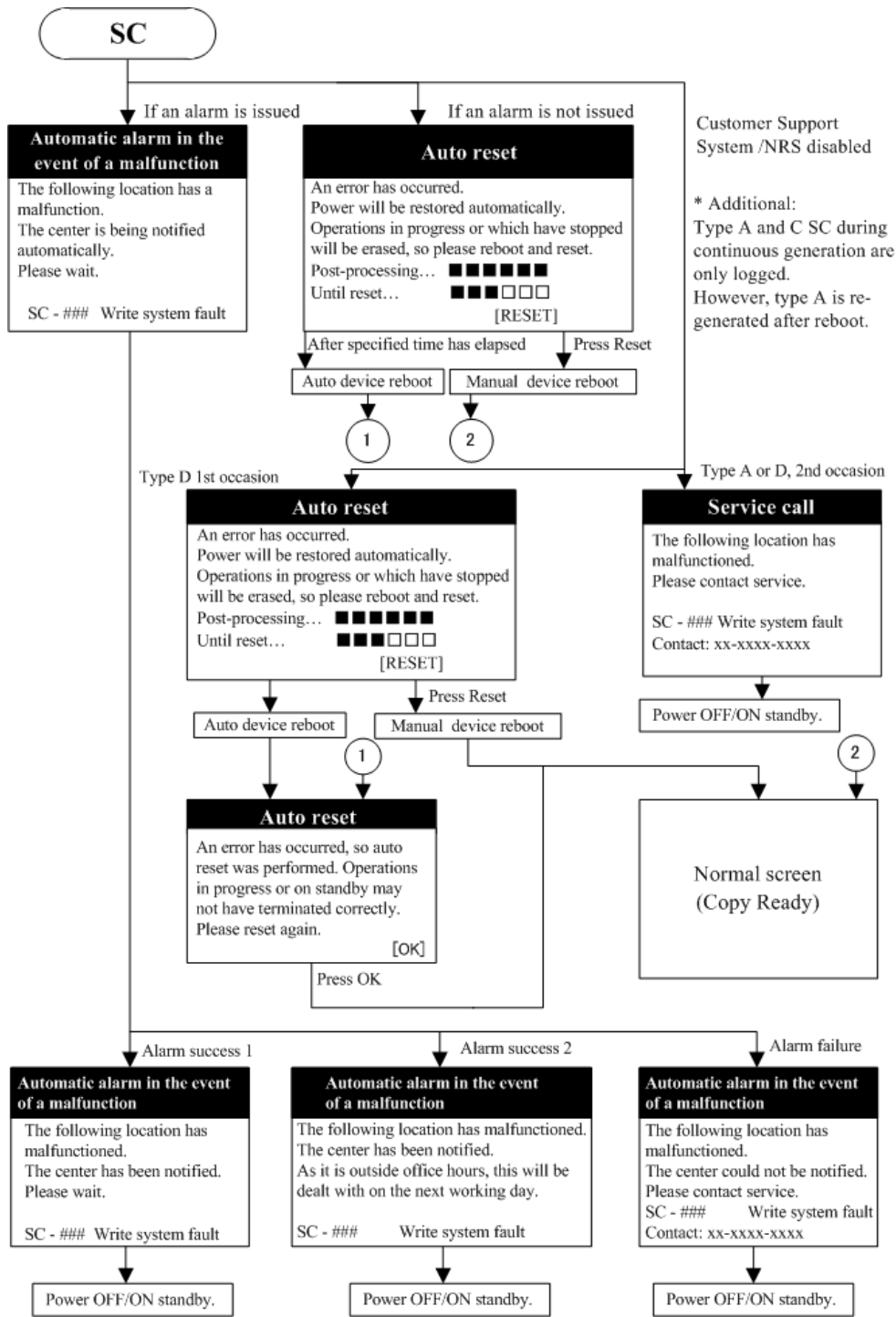

Customer Support System /NRS disabled

\* Additional:  
Type A and C SC during continuous generation are only logged. However, type A is re-generated after reboot.

w\_d1462643

## 5.2 SC1XX

### 5.2.1 SC101-01

#### Error Name

LED Error

#### Type

D

#### Symptoms

The peak white level is less than the prescribed value.

#### Possible Causes

- The connection is loose.
- The LED is defective.
- The LED drive is malfunctioning.
- The BiCU is malfunctioning.
- The mirrors or lenses are not set properly, or are dirty.
- The harness is defective.
- The white plate is not set properly, or is dirty.
- The ARDF's white plate is dirty or defective (intermittent shading model only).

#### Troubleshooting Procedures

Turn OFF then ON the main power.

If the SC occurs again, check the following. After each step, turn OFF then ON the main power, and see if the SC recurs.

#### 1. Check the ARDF's white plate (white roller).

- Not dirty or defective: Proceed to the next step.
- Dirty or defective: Clean or replace the white plate.

If the SC recurs after power OFF and ON, proceed to the next step.

#### 2. Check the connector between the CIS and the BiCU.

- Not loose or disconnected: Proceed to the next step.
- Loose or disconnected: Reconnect the connector.

If the SC recurs after power OFF and ON, proceed to the next step.

#### 3. Execute an output check for the LEDs (SP5-804-202).

- Not defective: Proceed to the next step.
- Defective: Replace the LEDB and execute SP5-804-202 again. If the LED lights up, proceed to the next step. If not, replace the CIS. If the SC recurs after power OFF and ON, proceed to the next step.

#### 4. Check the BiCU. If it is malfunctioning, replace it.

If the SC recurs after power OFF and ON, proceed to the next step.

#### 5. Check the harness. If it is defective, replace the harness.

If the SC recurs after power OFF and ON, proceed to the next step.

**6. Check the white plate (exposure glass).**

If it is dirty or defective, replace it. Turn OFF then ON the main power to see if the SC recurs.

## 5.2.2 SC102-00

### Error Name

LED Intensity Adjustment Error

### Type

D

### Symptoms

The peak white level cannot reach the prescribed value even though adjusting several times.

### Possible Causes

- The connection is loose.
- The LED is defective.
- The LED drive is malfunctioning.
- The CIS is malfunctioning.
- The BiCU is malfunctioning.
- The harness is defective.

### Troubleshooting Procedures

Turn OFF then ON the main power.

If the SC occurs again, check the following. After each step, turn OFF then ON the main power, and see if the SC recurs.

**1. Check the ARDF's white plate (white roller).**

- Not dirty or defective: Proceed to the next step.
- Dirty or defective: Clean or replace the white plate.

If the SC recurs after power OFF and ON, proceed to the next step.

**2. Check the connector between the CIS and the BiCU.**

- Not loose or disconnected: Proceed to the next step.
- Loose or disconnected: Reconnect the connector.

If the SC recurs after power OFF and ON, proceed to the next step.

**3. Execute an output check for the LEDs (SP5-804-202).**

- Not defective: Proceed to the next step.
- Defective: Replace the LEDB and execute SP5-804-202 again. If the LED lights up, proceed to the next step. If not, replace the CIS. If the SC recurs after power OFF and ON, proceed to the next step.

**4. Check the BiCU. If it is malfunctioning, replace it.**

If the SC recurs after power OFF and ON, proceed to the next step.



**5. Replace the laser unit.**

If the SC recurs after power OFF and ON, proceed to the next step.

**6. Check the harness. If it is defective, replace the the harness.**

If the SC recurs after power OFF and ON, proceed to the next step.

**7. Check the white plate (exposure glass).**

If it is dirty or defective, replace it. Turn OFF then ON the main power to see if the SC recurs.

**5.2.3 SC120-00, SC121-00****Error Name**

SC120-00: Scanner Home Position (HP) Error 1

SC121-00: Scanner Home Position (HP) Error 2

**Type**

D

**Symptoms**

The scanner HP sensor does not turn OFF.

This SC is detected during:

- Scanner homing (power ON/ recovery from Energy Save)
- Auto-adjustment (power ON/ recovery from Energy Save)
- DF/FB scanning
- Original size detection

**Possible Causes**

- The connection is loose.
- The BiCU is malfunctioning.
- The scanner motor is malfunctioning.
- The board with the scanner control IC chip (BiCU) is malfunctioning.
- The HP sensor is malfunctioning.
- The harness is defective (broken or short-circuited).
- The timing belt, pulley, wires, carriage are not assembled correctly.

**Troubleshooting Procedures**

Turn OFF then ON the main power.

If the SC occurs again, check the following. After each step, Turn OFF then ON the main power, and see if the SC recurs.

**1. Check all connectors.**

- Not loose or disconnected: Proceed to the next step.
- Loose or disconnected: Reconnect the connector.

If the SC recurs after power OFF and ON, proceed to the next step.

2. **Check the timing belt, pulley, wires, and carriage.**
  - Correctly assembled: Proceed to the next step.
  - Wrongly assembled: Assemble the scanner carriage and bracket again.
3. **Check the HP sensor. If it is defective, replace it.**  
If the SC recurs after power OFF and ON, proceed to the next step.
4. **Check the BiCU (motor drive PCB). If it is defective, replace the PCB.**  
If the SC recurs after power OFF and ON, proceed to the next step.
5. **Check the scanner motor. If it is malfunctioning, replace it.**  
If the SC recurs after power OFF and ON, proceed to the next step.
6. **Check the board with the scanner control IC chip (BiCU). If it is defective, replace the PCB.**  
If the SC recurs after power OFF and ON, proceed to the next step.
7. **Check the harness. If it is defective, replace harness.**

## 5.2.4 SC141-00

### Error Name

Black Level Detection Error

### Type

D

### Symptoms

The black level is not within the prescribed value.

This SC is detected when the scanner turned ON (power ON/ recovery from Energy Save).

### Possible Causes

- The CIS is defective.
- The BiCU is malfunctioning.
- The harness is defective

### Troubleshooting Procedures

Turn OFF then ON the main power.

If the SC occurs again, check the following. After each step, Turn OFF then ON the main power, and see if the SC recurs.

1. **Check the CIS. If it is defective, replace it.**  
If the SC recurs after power OFF and ON, proceed to the next step.
2. **Check the BiCU. If it is defective, replace it.**  
If the SC recurs after power OFF and ON, proceed to the next step.

## 5.2.5 SC142-00

### Error Name

White Level Detection Error

### Type

D

### Symptoms

The white peak level is not within the prescribed value when adjusting the scanner gain.

This SC is detected when the scanner is turned ON (power ON/ recovery from Energy Save).

### Possible Causes

- There is condensation in the scanner unit.
- The LED is defective.
- The LED driver PCB is defective.
- The CIS is defective.
- The BiCU is malfunctioning.
- The harness is defective.
- The connection is loose.
- The mirrors or lenses are not set properly, or are dirty.
- The white plate is not set properly, or is dirty.
- The scanner motor is malfunctioning.

### Troubleshooting Procedures

Turn OFF then ON the main power.

If the SC occurs again, check the following. After each step, Turn OFF then ON the main power, and see if the SC recurs.

#### 1. Check the connector between the CIS and the BiCU.

- Not loose or disconnected: Proceed to the next step.
- Loose or disconnected: Reconnect the connector.

If the SC recurs after power OFF and ON, proceed to the next step.

#### 2. Execute an output check for the LEDs (SP5-804-202).

- Not defective: Proceed to the next step.
- Defective: Replace the LEDB and execute SP5-804-202 again. If the LED lights up, proceed to the next step. If not, replace the CIS. If the SC recurs after power OFF then ON, proceed to the next step.

#### 3. Check the BiCU. If it is defective, replace it.

If the SC recurs after power OFF and ON, proceed to the next step.

#### 4. Replace the laser unit.

If the SC recurs after power OFF and ON, proceed to the next step.

#### 5. Check the harness. If it is defective, replace the harness.

If the SC recurs after power OFF and ON, proceed to the next step.

6. **Check the white plate (exposure glass). If it is dirty or defective, replace it. Turn OFF then ON the main power to see if the SC recurs.**

## 5.2.6 SC144-00

### Error Name

Scanner Communication Error

### Type

D

### Symptoms

- Connection detection error
- Cannot communicate with scanning-related devices (AFE, FPGA, ASIC). Or there are communication errors.

This SC is detected when the scanner is turned ON (power ON/ recovery from Energy Save).

### Possible Causes

- The CIS is defective.
- The BiCU is malfunctioning.
- The harness is defective.

### Troubleshooting Procedures

Turn OFF then ON the main power.

If the SC occurs again, check the following. After each step, Turn OFF then ON the main power, and see if the SC recurs.

1. **Check the connector between the CIS and the BiCU.**

- Not loose or disconnected: Proceed to the next step.
- Loose or disconnected: Reconnect the connector.

If the SC recurs after power OFF and ON, proceed to the next step.

2. **Check the CIS. If it is defective, replace it.**

If the SC recurs after power OFF and ON, proceed to the next step.

3. **Check the BiCU. If it is defective, replace it.**

If the SC recurs after power OFF and ON, proceed to the next step.

## 5.2.7 SC165-00

### Error Name

Copy Data Security Unit Error

### Type

D

### Symptoms

The copy data security board cannot be detected, or a device check error occurred even though the copy data security function is set to "ON" in System Settings.

### Possible Causes

- The copy data security board is not installed properly.
- The copy data security board is malfunctioning.

### Troubleshooting Procedures

- Reinstall the copy data security board.
- Replace the copy data security board.

## 5.3 SC2XX

### 5.3.1 SC202-00, SC203-00, SC204-00

#### Error Name

SC202-00: Polygon Motor Error: ON Timeout

SC203-00: Polygon Motor Error: OFF Timeout

SC204-00: Polygon Motor Error 0: XSCRDY Signal Error

#### Type

D

#### Symptoms

- SC202-00  
The polygon mirror motor cannot rotate correctly.  
This SC is detected when the polygon mirror motor starts rotating (start of printing), or when its rotating speed is changed (change in printing speed).
- SC203-00  
The polygon mirror motor cannot stop rotating correctly.  
This SC is detected when the polygon mirror motor stops rotating (end of printing), or when its rotating speed (printing speed) is changed.
- SC204-00  
The polygon mirror motor cannot rotate correctly during printing.  
This SC is detected when the polygon mirror motor rotates before printing and during printing.

#### Possible Causes

- The polygon mirror motor or the polygon mirror motor driver is malfunctioning.
- The polygon mirror motor harness is defective, disconnected, or short-circuited.
- The BiCU is malfunctioning (incorrect polygon motor control signal, damaged Laser ASIC).
- The PSU is malfunctioning (main power supply or fuse of the polygon mirror motor is defective).
- The AC voltage is wrong.

#### Troubleshooting Procedures

1. Turn OFF then ON the main power.
2. Check the harness between the LD unit and the BiCU.
3. Check the 24V power source for the polygon mirror motor (CN286, a 6-pin connector on the PSU).
4. Replace the Laser unit.
5. Replace the harness between the LD unit and the BiCU.
6. Replace the BiCU.



## 7. Replace the PSU.

If a multimeter is available, perform Step 3. If the meter indicates between 22 to 26V, the power source is normal.

You cannot change only the polygon mirror motor.

### 5.3.2 SC220-00

#### Error Name

Laser Synchronizing Detection Error: Start Position LD1

#### Type

D

#### Symptoms

Synchronizing detection signal cannot be received.

This SC is detected when the machine starts up, or when it is printing.

#### Possible Causes

- The LD unit is malfunctioning (synchronizing mechanism or LDB failure).
- The BiCU is malfunctioning (damaged Laser ASIC).
- The LDB harness is loose or broken.

#### Troubleshooting Procedures

1. Turn OFF then ON the main power.
2. Check if there is condensation on the LDB.
3. Check the harness between the LDB and the BiCU. Replace it if needed.
4. Replace the Laser unit.
5. Replace the BiCU.

### 5.3.3 SC230-00, SC231-00

#### Error Name

SC230-00: FGATE ON Error

SC231-00: FGATE OFF Error

#### Type

D

#### Symptoms

- SC230-00  
An FGATE signal is not sent even when the laser is ready to be emitted.
  - SC231-00  
The FGATE signal does not go OFF even when laser emission is going to end.
- These SCs are detected during printing.

#### Possible Causes

- The connection between the BiCU and the controller is loose.
- The BiCU is malfunctioning (damaged Laser ASIC).

#### Troubleshooting Procedures

1. Turn OFF then ON the main power.
2. Check the connection between the BiCU and the controller.
3. Replace the BiCU.

### 5.3.4 SC240-00

**Error Name**

LD Error

**Type**

D

**Symptoms**

- During light emission, the LD current exceeds the prescribed current.
- The LD driver cannot be initialized.
- The LDB harness is defective.

This SC is detected when the machine starts up, or when it is printing.

**Possible Causes**

- The LDB harness is loose.
- The LD has deteriorated (LD is damaged, or the current-to-output optical power characteristic is not good).
- The LDB is malfunctioning (the LD driver is defective).
- The LDB harness is loose (disconnected).

**Troubleshooting Procedures**

1. **Turn OFF then ON the main power.**
2. **Check SP2-110-001.**
  - If the value is "0", perform Step 4.
  - If the value is "1", perform Step 3.
  - If the value is between "2" and "FF", perform Step 4.
3. **Check the harness between the LDB and the BiCU. Replace it if needed.**
4. **Replace the Laser unit.**

### 5.3.5 SC270-00

#### Error Name

Laser ASIC Communication Error

#### Type

D

#### Symptoms

There is a communication error between the CPU and the laser ASIC.

This SC is detected when the main power is turned ON, when the machine recovers from Energy Save, or during printing.

#### Possible Causes

- The connection between the BiCU and the LDB is loose.
- The BiCU is malfunctioning (the laser ASIC is defective, or the I/F between the CPU and the laser ASIC is defective).

#### Troubleshooting Procedures

1. Turn OFF then ON the main power.
2. Check the connection between the BiCU and the LDB.
3. Replace the BiCU.

### 5.3.6 SC272-01

**Error Name**

LD Driver Communication Error

**Type**

D

**Symptoms**

There is a communication error between the CPU and the LD driver.

This SC is detected when the main power is turned ON, when the machine recovers from Energy Save, or during printing.

**Possible Causes**

- The LDB is malfunctioning (LD driver is defective).
- The BiCU is malfunctioning (the I/F between the CPU and the LD driver is defective).
- The LDB harness is defective.

**Troubleshooting Procedures**

1. Turn OFF then ON the main power.
2. Check the harness between the LDB and BiCU. Replace it if needed.
3. Replace the Laser unit.
4. Replace the BiCU.
5. Replace the harness between the LDB and the BiCU.

### 5.3.7 SC272-10

#### Error Name

LD Driver Communication Error: Others

#### Type

D

#### Symptoms

The power source of the LD board is wrong.

This SC is detected when the main power is turned ON, the machine recovers from Energy Save, or when covers are closed.

#### Possible Causes

- The BiCU is malfunctioning (LD5V power source is wrong).
- The LDB is malfunctioning (LD driver is defective).
- The LDB harness is defective.
- The interlock switch is defective.

#### Troubleshooting Procedures

1. Turn OFF then ON the main power.
2. Check the harness between the LDB and BiCU. Replace it if needed.
3. Replace the BiCU.
4. Replace the Laser unit.
5. Replace the harness between the LDB and the BiCU.
6. Replace the interlock switch.



## 5.4 SC3XX

### 5.4.1 SC302-00

#### Error Name

HVPS: Charge Roller Error

#### Type

D

#### Symptoms

When a PWM signal is being outputted, the machine checks for incorrect signals once every 20ms, and “L” (an incorrect signal) was detected for ten consecutive times.

#### Possible Causes

- Hardware-related causes:
  - The HVPS output connector is loose.
  - The connector on the BiCU board is loose.
  - The HVPS charge roller harness has short-circuited.
  - There is not sufficient creeping distance or spatial distance (arc discharge).
  - The harness on the BiCU board has short-circuited.
  - The BiCU is malfunctioning (related signal errors).
  - The HVPS is defective.
- Load-related causes:
  - There is a grounding fault when charging, or there is a short circuit with other power outputs.
  - There is not sufficient creeping distance or spatial distance in the charging output path (including the distance from other power outputs).
  - There is abnormal deterioration of the PCU or excessive current because of a pinhole.
  - There is an abnormal gap between the PCU and the charge roller (PCU is defective).
  - There is excessive current due to condensation on the PCU.
  - The PCU is not installed correctly.

#### Troubleshooting Procedures

Depending on the machine model, the defective part and whether it can be serviced is different. Change the order of the steps as necessary.

This SC is detected when processing a printing job. After performing the following steps, it is necessary to turn OFF then ON the main power in order to resend the job.

1. **After turning OFF then ON the main power, print one sheet of paper to see if the SC recurs.**
2. **Install the PCU again.**
3. **Replace the PCU.**

4. Reconnect the CN108 connector on the BiCU.
5. Reconnect the CN800 connector and T1 of the HVPS.
6. Replace the HVPS.
7. Replace the BiCU.
8. Replace that harness of the charge roller (output).

## 5.4.2 SC355-00

### Error Name

ID Sensor Error

### Type

C

### Symptoms

When this SC is detected during normal operation, it will be logged in the SC History. The SC code will not be displayed on the operation panel.

### Possible Causes

- The ID sensor is malfunctioning, or the ID sensor harness is broken.
- The ID sensor connector is loose, or the BiCU is malfunctioning.
- There are scanning errors, or the image density is not correct.
- The HVPS is defective, or the ID sensor is dirty.

### Troubleshooting Procedures

- Replace the ID sensor.
- Reconnect the ID sensor connector.
- Turn OFF then ON the main power.

### 5.4.3 SC360-01

#### Error Name

TD Sensor Error

#### Type

D

#### Symptoms

The mu count (mu sensor) is not within the target range for three consecutive times.

#### Possible Causes

- The TD sensor is malfunctioning.
- The connection is loose, or the harness is broken.
- There is no developer.

#### Troubleshooting Procedures

**1. Check all the connectors.**

- Not loose or disconnected: Proceed to the other steps.
- Loose or disconnected: Reconnect the connectors.

If the SC recurs after power OFF and ON, proceed to the other steps.

**2. Visually inspect the development unit to see if the gear or harness is loose, the heat protection seal is not removed, or whether it is a used PCDU.**

If there is a problem with the development unit, solve the problem in the prescribed way, or replace the development unit.

If the SC recurs after power OFF and ON, proceed to the other steps.

**3. Visually inspect the mu sensor to see if it is deformed, scratched, damaged, or if there is a foreign object. If there is a problem, replace the PCDU.**

If the SC recurs after power OFF and ON, proceed to the next step.

**4. Visually inspect the harnesses to see if they are damaged. Check the mu sensor harness, and the harness connecting the PCDU to the main machine. If there is a problem, replace the PCDU.**

If the SC recurs after power OFF and ON, proceed to the next step.

**5. Check if there is a problem with the BiCU.**

If the problem cannot be solved after performing all the above steps, replace the BiCU.

## 5.4.4 SC361-01, SC362-01

### Error Name

SC361-01: TD Sensor Upper Limit Error (Bk)

SC362-01: TD Sensor Lower Limit Error (Bk)

### Type

D

### Symptoms

- SC361-01  
TS Sensor Output: Vt (SP2-220-004) is detected to be higher than the upper limit threshold specified in SP2-992-001, for the consecutive number of times specified in SP2-992-003.
- SC362-01  
TS Sensor Output: Vt (SP2-220-004) is detected to be lower than the lower limit threshold specified in SP2-992-002, for the consecutive number of times specified in SP2-992-004.

### Possible Causes

The TD sensor connector is loose.

### Checking Procedure

1. **After turning OFF then ON the main power, feed one sheet of paper.**
2. **Check the value of the TD Sensor Output: Vt (SP2-220-004).**
3. **For SC361-01, check if TD Sensor Output: Vt is higher than the upper limit threshold specified in SP2-992-001. If the Vt is equal or less than the upper limit threshold, it is normal. If the Vt is higher than the upper limit threshold, there is a problem.**
4. **For SC362-01, check if TD Sensor Output: Vt is lower than the lower limit threshold specified in SP2-992-002. If the Vt is equal or more than the lower limit threshold, it is normal. If the Vt is lower than the lower limit threshold, there is a problem.**

### Troubleshooting Procedures

1. **Check all the connectors.**
  - Not loose or disconnected: Proceed to the other steps.
  - Loose or disconnected: Reconnect the connectors.

If the SC recurs after power OFF and ON, proceed to the other steps.
2. **Visually inspect the development unit to see if the gear is loose, the harness is damaged, or if the development unit is not set properly. If there is a problem with the development unit, solve the problem in the prescribed way, or replace the development unit.**

If the SC recurs after power OFF and ON, proceed to the other steps.
3. **Visually inspect the mu sensor to see if it is deformed, scratched, damaged, or if**

**there is a foreign object. If there is a problem, replace the PCDU.**

If the SC recurs after power OFF and ON, proceed to the other steps.

4. **Clear the NVRAM, and check if the parameter settings are correct. For example, the mu count (SP2-803-003) should be the factory default value.**

If there is a problem, replace the development unit, and then perform TD sensor calibration.

If the SP value is correct, proceed to the other steps.

5. **Check the toner supply unit. (If the image density is too low, there may be a problem with supplying toner.)**

- Check if the toner bottle is empty.
- Check if the toner supply motor is operating normally.
- Check if the toner supply path is clogged.

If there is a problem with the toner supply unit, solve the problem in the prescribed way.

If the SC recurs after power OFF and ON, proceed to the other steps.

6. **Visually inspect the harnesses to see if they are damaged. Check the mu sensor harness, and the harness connecting the development unit to the main machine.**

If there is a problem, replace the harness.

7. **Check if there is a problem with the BiCU.**

If the problem cannot be solved after performing all the above steps, replace the BiCU.

## 5.4.5 SC391-00

### Error Name

HVPS Charge Error

### Type

D

### Symptoms

When a PWM signal is being outputted, the machine checks for incorrect signals once every 20ms, and “L” (an incorrect signal) was detected for ten consecutive times.

### Possible Causes

- Hardware-related causes:
  - The HVPS output connector is loose.
  - The connector on the BiCU board is loose.
  - The HVPS charge roller harness has short-circuited.
  - There is not sufficient creeping distance or spatial distance (arc discharge).
  - The harness on the BiCU board has short-circuited.
  - The BiCU is malfunctioning (related signal errors).
  - The HVPS is defective.
- Load-related causes:
  - There is a grounding fault when charging, or there is a short circuit with other power

outputs.

- There is not sufficient creeping distance or spatial distance in the charging output path (including the distance from other power outputs).
- There is abnormal deterioration of the PCU, or excessive current due to a pinhole.
- There is an abnormal gap between the PCU and the charge roller (PCU is defective).
- There is excessive current due to condensation on the PCU.
- The PCU is not installed correctly.

### **Troubleshooting Procedures**

Depending on the machine model, the defective part and whether it can be serviced is different. Change the order of the steps as necessary.

This SC is detected when processing a printing job. After performing the following steps, it is necessary to turn OFF then ON the main power in order to resend the job.

- 1. After turning OFF then ON the main power, print one sheet of paper to see if the SC recurs.**
- 2. Install the PCU again.**
- 3. Replace the PCU.**
- 4. Reconnect the CN108 connector on the BiCU.**
- 5. Reconnect the CN800 connector and T1 of the HVPS.**
- 6. Replace the HVPS.**
- 7. Replace the BiCU.**
- 8. Replace the harness of the charge roller (output).**

## 5.4.6 SC392-00

### Error Name

Developer Set Error

### Type

D

### Symptoms

A scanning error has occurred with the ID sensor pattern that is generated during initialization.

This SC is detected if the heat protection seal is not removed, or there is no developer when the Vsp output is 2.5V or more.

### Possible Causes

- The heat protection seal is not removed.
- The ID sensor is defective.
- The PCDU is not rotating.
- The development roller is not rotating.

### Troubleshooting Procedures

Turn OFF then ON the main power, and see if the SC recurs.

#### 1. Check all the connectors.

- Not loose or disconnected: Proceed to the other steps.
- Loose or disconnected: Reconnect the connectors.

If the SC recurs after power OFF and ON, proceed to the next step.

#### 2. Visually inspect the development unit to see if the gear is loose, the harness is damaged, or if the development unit is not set properly. If there is a problem with the development unit, solve the problem in the prescribed way, or replace the development unit.

If the SC recurs after power OFF and ON, proceed to the next step.

#### 3. Visually inspect the PCDU. See if it is scratched, damaged, or if there is a foreign object. If there is a problem, replace the PCDU.

If the SC recurs after power OFF and ON, proceed to the next step.

#### 4. Check if the ID sensor is defective. If it is defective, replace the ID sensor.

#### 5. Visually inspect the harnesses to see if they are damaged.

Check the mu sensor harness, and the harness connecting the development unit to the main machine. If there is a problem, replace the harness.

If the SC recurs after power OFF and ON, proceed to the next step.

#### 6. Check if there is a problem with the BiCU.

If the problem cannot be solved after performing all the above steps, replace the BiCU.



## 5.5 SC 4XX

### 5.5.1 SC440-00

#### Error Name

HVPS Transfer Output Error

#### Type

D

#### Symptoms

When a PWM signal is being outputted, the machine checks for incorrect signals once every 20ms. This SC is displayed when "L" (an incorrect signal) is detected for ten consecutive times.

#### Possible Causes

- Hardware-related causes:
  - The HVPS output connector is loose.
  - The connector on the BiCU is loose.
  - The HVPS harness is damaged or has short-circuited.
  - The harness on the BiCU has short-circuited.
  - The BiCU is malfunctioning.
  - The HVPS is defective.
- Load-related causes:
  - There is increased impedance of the image transfer roller (due to low temperature or dirty roller).
  - There is an open short circuit in the power feed path.
  - The image transfer unit is not installed properly.

#### Troubleshooting Procedures

Depending on the machine model, the defective part and whether it can be serviced is different. Change the order of the steps as necessary.

This SC is detected when processing a printing job. After performing the following steps, it is necessary to turn OFF then ON the main power in order to resend the job.

- 1. After turning OFF then ON the main power, print one sheet to see if the SC recurs.**
- 2. Install the image transfer unit again.**

Before re-installation, check if the shaft plate of the transfer roller and the HVPS are properly connected. If power is not supplied from the HVPS to the transfer roller, the voltage will rise and cause this SC.
- 3. Replace the transfer unit.**
- 4. Reconnect the CN108 connector on the BiCU.**
- 5. Reconnect the CN800 connector and T3 of the HVPS.**
- 6. Replace the HVPS.**

7. **Replace the BiCU.**
8. **Replace the transfer output harness of the HVPS.**

## 5.5.2 SC460-00

### Error Name

HVPS Isolated Output Error

### Type

D

### Symptoms

When a PWM signal is being outputted, the machine checks for incorrect signals once every 20ms. This SC is displayed when “L” (an incorrect signal) is detected for ten consecutive times.

### Possible Causes

- Hardware-related causes:
  - The HVPS output connector is loose.
  - The connector on the BiCU is loose.
  - The HVPS harness has short-circuited.
  - The harness on the BiCU has short-circuited.
  - The image transfer unit is not installed properly.
  - The BiCU is malfunctioning.
  - The HVPS is defective.
- Load-related causes:
  - There is a short circuit in the output isolation module, or a short circuit involving other power outputs.
  - There is not sufficient creeping distance or spatial distance in the isolated output path (including the distance from other power outputs).

### Troubleshooting Procedures

Depending on the machine model, the defective part and whether it can be serviced is different. Change the order of the steps as necessary.

This SC is detected when processing a printing job. After performing the following steps, it is necessary to turn OFF then ON the main power in order to resend the job.

1. **After turning OFF then ON the main power, print one sheet to see if the SC recurs.**
2. **Install the image transfer unit again.**

When installing, make sure that the static charge eliminator and the junction plate spring are not bent, and that they are properly connected to the main machine's frame.

3. **Replace the transfer unit.**
4. **Reconnect the CN108 connector on the BiCU.**
5. **Reconnect the CN800 connector and T4 of the HVPS.**
6. **Replace the HVPS.**

7. **Replace the BiCU.**
8. **Replace the transfer output harness of the HVPS.**

### **5.5.3 SC497-00**

#### **Error Name**

Internal Temperature Sensor Error

#### **Type**

C

#### **Symptoms**

This SC is detected when the internal temperature sensor output is 0.56V or less, or 3.0V or more.

#### **Possible Causes**

- The internal temperature sensor is not installed properly (connector is loose or damaged).
- The internal temperature sensor is malfunctioning.

#### **Troubleshooting Procedures**

1. **Turn OFF then ON the main power, and see if the SC recurs.**
2. **Check the connectors of the internal temperature sensor and the BiCU (check for loose connections).**
3. **Replace the internal temperature sensor.**

### **5.5.4 SC498-00**

#### **Error Name**

Temperature/Humidity Sensor Error

#### **Type**

C

#### **Symptoms**

This SC is detected when:

- the temperature sensor output is 0.76V or less, or 2.90V or more.
- the humidity sensor output is 2.4V or more.

#### **Possible Causes**

- The sensor is loose or damaged.
- The sensor is defective.

#### **Troubleshooting Procedures**

1. **Turn OFF then ON the main power, and see if the SC recurs.**
2. **Check the connectors of the sensor and the BiCU (check for loose connections).**
3. **Replace the temperature/humidity sensor.**

## 5.6 SC5XX

### 5.6.1 SC502-01

#### Error Name

2nd Paper Tray Lift Error

#### Type

B

#### Symptoms

- Upper Limit Detection Error (during normal tray lift)  
During tray initialization, the tray bottom plate was lifted, but the upper limit cannot be detected within 10000ms.
- Upper Limit Detection Error (during paper feed)  
During tray initialization, the tray bottom plate was lifted, but the upper limit cannot be detected within 3000ms.

This error occurs when the upper limit cannot be detected for three consecutive times. If the upper limit cannot be detected for two consecutive times, "Reset tray" is displayed.

#### Possible Causes

- The lift motor is malfunctioning, or the connector is loose or damaged.
- The upper limit sensor is malfunctioning, or the connector is loose or damaged.
- The harnesses are damaged.
- The PCB is malfunctioning.
- There is foreign matter such as paper scraps caught between the paper feed tray and the tray lift motor.
- The limit sensor feelers are damaged.
- The paper is not set properly.
- The bottom plate is damaged.
- The paper feed rollers are missing.
- The lift up arm is damaged.

#### Troubleshooting Procedures

Turn OFF then ON the main power.

If the SC occurs again, check the following. After each step, turn OFF then ON the main power, and see if the SC recurs.

1. **Remove the paper tray. Check for foreign matter inside and around the paper tray.**
2. **Reconnect the limit sensor connector (check for loose connections).**
3. **Check the limit sensor feelers, paper feed rollers, and lift up arm (including the tension spring). If they are defective, replace them.**
4. **Check the lift motor. If it is defective, replace it.**
5. **Check the harnesses. If they are defective, replace them.**

6. **Check the paper tray PCB. If it is defective, replace it.**

## 5.6.2 SC502-02

### Error Name

2nd Paper Tray Descent Error

### Type

B

### Symptoms

- Descent Detection Error (during tray descent)  
When there is no paper, the tray bottom plate descends, but the upper limit sensor does not turn OFF even though 1000ms have elapsed.
- Overload Sensor Error (during tray descent)  
If paper end and upper limit is detected at power ON or tray installation, the upper limit sensor will not turn OFF even though 1000ms have elapsed.

This SC occurs when the error recurs for five consecutive times. If the error recurs for four consecutive times, "Reset tray" is displayed.

### Possible Causes

- The tray is overloaded.
- The lift motor is malfunctioning, or the connector is loose or damaged.
- The upper limit sensor is malfunctioning, or the connector is loose or damaged.
- The harnesses are damaged.
- The PCB is malfunctioning.
- There is foreign matter such as paper scraps caught between the paper feed tray and the tray lift motor.
- The limit sensor feelers are damaged.
- The paper is not set properly.
- The bottom plate is damaged.
- The paper feed rollers are missing.
- The lift up arm is damaged.

### Troubleshooting Procedures

Turn OFF then ON the main power.

If the SC occurs again, check the following. After each step, turn OFF then ON the main power, and see if the SC recurs.

1. **Remove the paper tray. Check for foreign matter inside and around the paper tray.**
2. **Reconnect the limit sensor connector (check for loose connections).**
3. **Check the limit sensor feelers, paper feed rollers, and lift up arm (including the tension spring). If they are defective, replace them.**
4. **Check the lift motor. If it is defective, replace it.**
5. **Check the harnesses. If they are defective, replace them.**

6. Check the paper tray PCB. If it is defective, replace it.

### 5.6.3 SC520-00

#### Error Name

Main Motor Error

#### Type

D

#### Symptoms

The machine detects a lock signal from the drive motor.

#### Possible Causes

The motor lock sensor remains High for more than 2 secs when the motor is ON.

#### Troubleshooting Procedures

Turn OFF then ON the main power. Execute an output check (SP5-804-001). If the SC recurs, perform the following steps.

Depending on the machine model, the defective part and whether it can be serviced is different. Change the order of the steps as necessary.

1. **Check the motor-driven units (PCDU, fusing, paper feed, bypass, duplex, paper exit, registration).**

- Removable units (fusing, PCDU, paper feed):

Remove the unit and check for external damage or wear. Rotate the feed rollers by hand and check if there is abnormal load, movement or noise. Depending on the machine type, replace the unit or the part.

- Non-removable units:

As far as possible, visually inspect for external damage or wear. If there are movable parts, move them by hand and check if there is abnormal load, movement or noise.

Depending on the machine type, replace the unit or the part.

2. **Reconnect the connectors (check for loose connections).**

3. **Check the gear, motor and timing belt inside the motor unit.**

When moving the parts by hand, move them in the same direction as in normal operation.

- If there is no visible damage, move them by hand and check if there is abnormal load, movement or noise. Depending on the machine type, replace the unit or the part.
- If there is visible damage, replace either the unit or the part depending on the machine type.

4. **Check the main motor.**

When moving the parts by hand, move them in the same direction as in normal operation.

- If there is no visible damage, move the rotor by hand and check if there is abnormal load, movement or noise. If there is a problem, replace the main motor and check if the SC recurs.
- If there is visible damage, replace the main motor and check if the SC recurs.

- 5. Check the BiCU. If the BiCU is defective, replace it.**
- 6. Perform conduction tests on the harness between the following pins on the BiCU.**
  - Pin 10 of the motor connector and pin CN103-1
  - Pin 9 of the motor connector and pin CN103-2
  - Pin 8 of the motor connector and pin CN103-3
  - Pin 7 of the motor connector and pin CN103-4
  - Pin 4 of the motor connector and pin CN103-7
  - Pin 3 of the motor connector and pin CN103-8
  - Pin 2 of the motor connector and pin CN103-9
  - Pin 1 of the motor connector and pin CN103-10



## 5.6.4 SC521-00

### Error Name

2nd Tray Paper Feed Motor Error

### Type

B

### Symptoms

- Encoder Error  
There is no A-phase/B-phase signal.
- Encoder Phase Pulse Over Error  
The difference between the A-phase and the B-phase is larger than the specified pulse count.
- Rotary Hold Time Over Error (Overload)  
There was no A-phase/B-phase signal within the specified period of time.

### Possible Causes

- The 2nd tray paper feed motor is defective.
- The harness is damaged.
- The connector is loose.
- The PCB is defective.

### Troubleshooting Procedures

Turn OFF then ON the main power.

If the SC occurs again, check the following. After each step, turn OFF then ON the main power, and see if the SC recurs.

1. **Check the connector of the 2nd tray paper feed motor. If it is loose, reconnect it.**
2. **Check the gears, paper feed rollers, and lift up arm (including the tension spring). If they are defective, replace them.**
3. **Check the harness. If it is defective, replace it.**
4. **Check the 2nd tray paper feed motor. If it is defective, replace it.**
5. **Check the paper tray PCB. If it is defective, replace it.**

## 5.6.5 SC534-00

### Error Name

Main Machine Exhaust Fan Error

### Type

D

### Symptoms

When the exhaust fan motor is ON, the machine checks for a lock signal once every 100ms.

This SC is displayed when a lock signal cannot be detected for 50 consecutive times.

### Possible Causes

- The exhaust fan motor is malfunctioning.
- The connector is loose.
- The harness is damaged.
- The BiCU is defective.

### Troubleshooting Procedures

1. **Turn OFF then ON the main power. Execute an output check (SP5-804-027).**

If the SC recurs, perform all the steps below. If the SC does not recur, perform only Step 3.

After each step, turn OFF then ON the main power, and see if the SC recurs.

2. **Check the connector between the fan and the harness. If the connection is loose, reconnect the connector.**
3. **Check the connector between the PCB and the harness. If the connection is loose, reconnect the connector.**
4. **Check the fan to see if there is any foreign object that is obstructing rotation. If so, remove the foreign object.**
5. **Replace the fan.**
6. **Check the harness. If it is defective, remove the harness. (If you have difficulty replacing the harness at this point, start from Step 6.)**
7. **Check the BiCU. If it is defective, replace it.**

## 5.6.6 SC534-01

### Error Name

Main Machine Air Intake Fan Error

### Type

D

### Symptoms

When the air intake fan motor is ON, the machine checks for a lock signal once every 100ms. This SC is displayed when a lock signal cannot be detected for 50 consecutive times.

### Possible Causes

- The air intake fan motor is malfunctioning.
- The connector is loose.
- The harness is damaged.
- The BiCU is defective.

### Troubleshooting Procedures

1. **Turn OFF then ON the main power. Execute an output check (SP5-804-008).**

If the SC recurs, perform all the steps below. If the SC does not recur, perform only Step 3.

After each step, turn OFF then ON the main power, and see if the SC recurs.

2. **Check the connector between the fan and the harness. If the connection is loose, reconnect the connector.**
3. **Check the connector between the PCB and the harness. If the connection is loose, reconnect the connector.**
4. **Check the fan to see if there is any foreign object that is obstructing rotation. If so, remove the foreign object.**
5. **Replace the fan.**
6. **Check the harness. If it is defective, remove the harness. (If you have difficulty replacing the harness at this point, start from Step 6.)**
7. **Check the BiCU. If it is defective, replace it.**

## 5.6.7 SC541-00, 02

### Error Name

SC541-00: Fusing Thermistor (Center) Connection Error

SC541-02: Fusing Thermistor (Center) Connection Error (Low power)

### Type

SC541-00: A

SC541-02: D(C)

### Symptoms

The fusing thermistor (center) detected that the temperature remained below 0°C for 8 secs when the fusing lamp is activated at power ON/ recovery from Energy Save/ rotation after reload/ before or during or after paper feed/ standby/ energy save/ low power mode.

### Possible Causes

- The thermistor is damaged.
- The connector is loose.

### Troubleshooting Procedures

1. **Reconnect the connector (inside the fusing unit and the main machine).**
2. **Replace the thermistor.**
3. **Replace the fusing unit.**
4. **Replace the BiCU.**

## 5.6.8 SC542-01, -03, -04, -06

### Error Name

SC542-01, -03: Fusing Thermistor (Center) Reload Error

SC542-04, -06: Fusing Thermistor (Center) Reload Error (Low power)

### Type

SC542-01, -03: A

SC542-04, -06: D(C)

### Symptoms

- SC542-01

The fusing thermistor (center) detected that the temperature remained below 22°C for a period of 3 secs for 5 consecutive times when the fusing unit motor is not rotating and the fusing lamp is activated, at power ON or recovery from Energy Save.

Measurement of the temperature gradient starts 2 secs after the fusing lamp is activated when the temperature is 45°C or higher. If the temperature is lower than 45°C, measurement starts 2 secs after the temperature exceeds 45°C. Temperature gradient detection is cancelled if the thermistor reaches the reload temperature during measurement.

- SC542-02

The fusing thermistor (center) cannot detect the reload temperature for a period of 36 secs when the fusing lamp is activated at power ON or recovery from Energy Save.

### Possible Causes

- The thermistor is dirty.
- The thermistor is deformed or loose.
- An input voltage other than that guaranteed is used.
- The overheat prevention device is activated.

### Troubleshooting Procedures

1. **Check the voltage. Reconnect the power plug.**
2. **Replace the thermistor.**
3. **Replace the fusing lamp.**
4. **Replace the BiCU.**

## 5.6.9 SC543-00, SC544-00

### Error Name

SC543-00: Fusing Thermistor (Center) High Temperature Error (Software)

SC544-00: Fusing Thermistor (Center) High Temperature Error (Hardware)

### Type

A

### Symptoms

- SC543-00  
The fusing thermistor (center) detected a temperature of over 230°C for 1 sec for 10 times or more, when the relay is activated at power ON/ recovery from Energy Save/ rotation after reload/ before or during or after paper feed/ standby/ energy save/ low power mode.
- SC544-00  
The fusing thermistor (center) detected a temperature of over 240°C when the relay is activated.

### Possible Causes

- The triac has short-circuited.
- The BiCU is defective.

### Troubleshooting Procedures

1. **Reconnect the connectors (main machine, BiCU).**
2. **Replace the thermistor.**
3. **Replace the harness inside the main machine.**
4. **Replace the BiCU.**

If the problem cannot be solved after performing the above steps, replace the fusing unit.

## 5.6.10 SC545-00, -04

### Error Name

SC545-00: Fusing Lamp Consecutive Full Power Error

SC545-04: Fusing Lamp Consecutive Full Power Error (Low power)

### Type

SC545-00: A

SC545-04: D(C)

### Symptoms

When the machine is in standby/energy save/low power mode, the fusing lamp remained lit for 30 secs or more after it was activated and the fusing drive has stopped.

### Possible Causes

- The thermistor is deformed or loose.
- The fusing lamp is damaged.
- The overheat prevention device is activated.

### Troubleshooting Procedures

1. **Check if there are paper scraps in the fusing unit.**
2. **Check the voltage. Reconnect the power plug,**
3. **Replace the fusing lamp.**
4. **Replace the thermistor.**
5. **Replace the BiCU.**



## 5.6.11 SC547-01, -02, -03

### Error Name

SC547-01: Zero Cross Error (Relay Contact Welding)

SC547-02: Zero Cross Error (Relay Contact Failure)

SC547-03: Zero Cross Error (Low Frequency Error)

### Type

D

### Symptoms

- SC547-01

A zero cross signal is detected when the relay is turned OFF.

This SC is detected before the fusing relay is activated (when the main power is turned ON, when the machine recovers from Engine Off mode, or when the interlock switch is turned from OFF to ON).

- SC547-02

A zero cross signal cannot be detected when the relay is turned ON.

This SC is detected immediately after the fusing relay is activated (when the main power is turned ON, when the machine recovers from Engine Off mode, or when the interlock switch is turned from OFF to ON).

- SC547-03

The frequency of the power source is less than 44Hz.

This SC is detected immediately after the fusing relay is activated, or when the main power is turned ON.

### Possible Causes

- SC547-01

- The fusing relay is damaged (there is contact welding).
- There is a fault in the fusing relay circuit.

- SC547-02

- The fusing relay is damaged (open circuit).
- There is a fault in the fusing relay circuit.
- The PSU fuse (24VS) is worn out.

- SC547-03

The frequency of the power source is unstable.

### Troubleshooting Procedures

SC547-01, SC547-02

1. Check the connection between the PSU and BiCU (check for any loose connections or damage).
2. Replace the PSU.
3. Replace the BiCU.

4. Replace the connector between the PSU and the BiCU (SC547-02).

SC547-03

1. Ensure that the frequency of the power source is 45Hz or more. If the frequency is less than 44Hz, there may be a problem with the infrastructure. Ask the customer's network administrator or facilities manager for assistance.
2. Replace the PSU.

## 5.6.12 SC549-00

### Error Name

Fusing Center Low Temperature Error

### Type

D

### Symptoms

When 40 secs have elapsed after registration restarted, the fusing thermistor (center) detected a compensated target temperature of -75°C for 30 secs.

### Possible Causes

- The fusing lamp is disconnected during paper transfer.
- The connection is loose.

### Troubleshooting Procedures

1. Check the power plug.
2. Replace the fusing lamp.
3. Replace the fusing thermistor (center).
4. Replace the BiCU.
5. Replace the AC board.

### **5.6.13 SC551-00, -02**

#### **Error Name**

SC551-00: Fusing Thermistor (End) Disconnection Error

SC551-02: Fusing Thermistor (End) Disconnection Error (Low power)

#### **Type**

SC551-00: A

SC551-02: D (C)

#### **Symptoms**

The fusing thermistor (end) detected a temperature of 0°C or less for 8 secs when the fusing lamp is activated at power ON/ recovery from Energy Save/ rotation after reload/ before or during or after paper feed/ standby/ energy save/ low power mode.

#### **Possible Causes**

- The thermistor is disconnected.
- The connection is loose.

#### **Troubleshooting Procedures**

1. **Reconnect the connectors (inside the fusing unit and the main machine).**
2. **Replace the fusing thermistor (end).**
3. **Replace the fusing unit.**
4. **Replace the BiCU.**

## 5.6.14 SC552-01, -03, -04, 06

### Error Name

SC552-01, -03: Fusing Thermistor (End) Reload Error

SC552-04, -06: Fusing Thermistor (End) Reload Error (Low power)

### Type

SC552-01, -03: A

SC552-04, -06: D (C)

### Symptoms

- SC552-01

The rise in temperature of the fusing thermistor (end) within 10 secs was 4°C or less. This was detected for 5 consecutive times when the fusing unit motor is not rotating and Fusing Lamp 2 is activated, at power ON or recovery from Energy Save.

Measurement of the temperature gradient starts 2 secs after the fusing lamp is activated (delay shift between heaters). If the temperature is lower than 45°C, measurement starts 2 secs after the temperature exceeds 45°C. Temperature gradient detection is cancelled if the thermistor reaches the reload temperature during measurement.

- SC552-03

The fusing thermistor (end) cannot detect the reload temperature for a period of 50 secs when Fusing Lamp 2 is activated at power ON or recovery from Energy Save.

### Possible Causes

- The thermistor is dirty.
- The thermistor is deformed or loose.
- An input voltage other than that guaranteed is used.
- The overheat prevention device is activated.

### Troubleshooting Procedure

1. **Check the voltage.**
2. **Change the power plug.**
3. **Replace the thermistor.**
4. **Replace the BiCU.**

## 5.6.15 SC553-00, SC554-00

### Error Name

SC553-00: Fusing Thermistor (End) High Temperature Error (Software)

SC554-00: Fusing Thermistor (End) High Temperature Error (Hardware)

### Type

A

### Symptoms

- SC553-00  
The fusing thermistor (end) detected a temperature of over 230°C for 1 sec for 10 times or more, when the relay is activated at power ON/ recovery from Energy Save/ rotation after reload/ before or during or after paper feed/ standby/ energy save/ low power mode.
- SC554-00  
The fusing thermistor (end) detected a temperature of over 240°C when the relay is activated.

### Possible Causes

- The triac has short-circuited.
- The BiCU is defective.

### Troubleshooting Procedures

1. **Reconnect the connectors (main machine, BiCU).**
2. **Replace the thermistor.**
3. **Replace the fusing thermistor harness inside the main machine.**
4. **Replace the BiCU.**

If the problem cannot be solved after performing the above steps, replace the fusing unit.

## 5.6.16 SC557-00

### Error Name

Zero Cross Frequency Over Error

### Type

C

### Symptoms

The frequency of the power source is 66Hz or more.

This SC is detected immediately after the relay is activated when the main power is turned ON.

### Possible Causes

The frequency of the power source is unstable, or there is noise.

### Troubleshooting Procedures

Nil

## 5.6.17 SC559-00

### Error Name

Consecutive (3 Times) Fusing Jam Error

### Type

A

### Symptoms

A fusing jam is detected for three consecutive times.

### Possible Causes

Paper is jammed in the fusing unit.

### Troubleshooting Procedures

1. Replace the separation plate.
2. Replace the fusing unit.
3. Replace the fusing drive gear (main machine).

## **5.7 SC6XX (INCLUDING CONTROLLER SERVICE CALLS)**

### **5.7.1 SC622-00**

#### **Error Name**

Paper Tray Communication Error

#### **Type**

D

#### **Symptoms**

This SC is detected when:

- there is a problem with the cable connection.
- there is a communication error notice from the paper tray.

#### **Possible Causes**

- The controller board of the paper tray is defective.
- The BICU is defective.
- The paper tray and the main machine are not properly connected.

#### **Troubleshooting Procedures**

- Replace the controller board of the paper tray.
- Replace the BICU.
- Replace or reconnect the cable between the paper tray and the main machine.



## 5.7.2 SC632-00, SC633-00, SC634-00, SC635-00

### Error Name

SC632-00: Counter Device Error 1

SC633-00: Counter Device Error 2

SC634-00: Counter Device Error 3

SC635-00: Counter Device Error 4

### Type

B/D

### Symptoms

- SC632-00  
After three attempts to send a data frame to the optional counter device via the serial communication line, no ACK signal was received within 100 ms.
- SC633-00  
After communication was established, the controller received a brake signal.
- SC634-00  
The counter device sent a backup RAM error.
- SC635-00  
The counter device sent a backup RAM error or a backup battery error.

### Possible Causes

- SC632-00, SC633-00  
The serial line between the counter device, the relay board and copier control board is disconnected or damaged.
- SC634-00, SC635-00  
The counter device control board or the backup battery of the counter device is defective.

### Troubleshooting Procedures

Nil

### 5.7.3 SC636-01

#### Error Name

IC Card Error

#### Type

D

#### Symptoms

This SC is detected when authentication using an external device is set to "ON", but:

- the authentication module is not installed.
- the SD card containing the authentication module is damaged, or the authentication module file is damaged.
- the DESS module is not installed.

#### Possible Causes

- The DESS module cannot be detected (machine models for which the DESS module is optional).
- The expanded authentication module cannot be detected.
- The SD card is damaged, or the expanded authentication module file is damaged.

#### Troubleshooting Procedures

Do one of the following:

- Use a valid SD card or a valid expanded authentication module file.
- Install a system/copy firmware that includes the latest DESS module.
- Make the following settings in the SP mode. Turn OFF then ON the main power.
  - Set SP5-401-160 to "0".
  - Set SP5-401-161 to "0".
- Replace the NVRAM.

## 5.7.4 SC636-02

### Error Name

IC Card Error

### Type

D

### Symptoms

This SC is detected when the version of the expanded authentication module is wrong.

### Possible Causes

The version of the expanded authentication module is not correct.

### Troubleshooting Procedures

Install the correct version.

## 5.7.5 SC637-01, -02

### Error Name

SC637-01: Tracking Information Notification Error

SC637-02: Tracking Information Notification Error (Management Server Error)

### Type

D

### Symptoms

This SC is detected when tracking information was lost.

### Possible Causes

- SC637-01
  - The tracking SDK application is defective.
  - There is an internal communication error.
- SC637-02
  - There is a network error.
  - There is a management server error.
  - The tracking SDK application is defective.

### Troubleshooting Procedures

Turn OFF then ON the main power.

## 5.7.6 SC641-00

### Error Name

Engine to Controller Communication Error (No Response)

### Type

D

### Symptoms

The controller sent a data frame by RAPI protocol, but there was no response after trying 3 times, once every 100ms.

### Possible Causes

- The controller board or software is defective.
- The engine board or software is defective.
- The controller board and the engine board are not connected properly.

### Troubleshooting Procedures

- Check the connection between the controller board and engine board.
- Turn OFF then ON the main power.

### 5.7.7 SC650-01, -04, -05, -13

#### Error Name

SC650-01: Remote Service Modem Communication Error (Dialup authentication failure)

SC650-04: Remote Service Modem Communication Error (Dialup Failure Because of Incorrect Modem Configuration)

SC650-05: Remote Service Modem Communication Error (Insufficient Power or Connection Fault)

SC650-13: Remote Service Modem Communication Error (RC Gate Type M was installed but there is no modem)

#### Type

C

#### Symptoms

An error related to communication using RC Gate Type M (such as dialup connection or modem board) was detected, or a problem that prevents RC Gate from operating was detected at power ON.

This SC is detected only when an error occurs during RC Gate operation.

An SC is not detected if an error occurred during RC Gate installation (because it can be referenced using SP).

The machine checks for SC650-13 during operation.

#### Possible Causes

- The SP settings are invalid.
- The modem line is disconnected.
- The modem board is disconnected.
- The wireless LAN card is not installed.

#### Troubleshooting Procedures

- SC650-01  
Check SP5-816-156 and SP5-816-157.
- SC650-04  
Check if SP5-816-160: AT Command is valid. If it is valid, then there is a bug in the software.
- SC650-05  
Nothing can be done because the line is not supported.
- SC650-13
  - If the modem board is not installed, install it.
  - Check if the settings for the modem driver (SP5-816-160, SP5-816-165 to 171, SP5-816-188 to SP5-816-189) are valid.
  - If the problem cannot be solved after performing the two steps above, replace the modem board.

## 5.7.8 SC650-14

### Error Name

Remote Service Modem Communication Error (RC Gate Type N was installed but modem is present, or wired/wireless LAN is not working)

### Type

C

### Symptoms

An error related to communication using RC Gate Type M was detected, or a problem that prevents RC Gate from operating was detected at power ON.

This SC is detected only when an error occurs during RC Gate operation.

An SC is not detected if an error occurred during RC Gate installation (because it can be referenced using SP).

### Possible Causes

- The SP settings are invalid.
- The modem line is connected.
- The modem board is installed.
- The wireless LAN card is not installed.

### Troubleshooting Procedures

- If the modem board is installed, remove the modem board.
- Check if the wired/wireless LAN is working.

## 5.7.9 SC651-01, -02

### Error Name

SC651-01: Invalid Remote Service Dial-up (Chat Program Parameter Error)

SC651-02: Invalid Remote Service Dial-up (Chat Program Execution Error)

### Type

C

### Symptoms

An unexpected error occurred when RC Gate Type M dialed up the NRS Center.

### Possible Causes

There is a bug in the software.

### Troubleshooting Procedures

Nil

## 5.7.10 SC652-00

### Error Name

Remote Service ID2 Mismatch Error

### Type

A

### Symptoms

ID2 on the machine-specific certificate and ID2 on the NVRAM do not match.

### Possible Causes

- The controller board has been used for another machine.
- The NVRAM has been used for another machine (this is not allowed).

ID2 of the machine-specific certificate is stored in the flash ROM of the controller board, and ID2 for RC Gate is stored in the NVRAM. Normally, both IDs should match. However, a mismatch may occur when the controller board is replaced. Because the machine cannot resolve the mismatch by itself, CE action is necessary.

### Troubleshooting Procedures

- If the SC was detected during RC Gate installation:  
Check the machine serial number. Check if the certificate matches the NVRAM. Write the same certificate for both, and then start RC Gate installation again.
- If the SC was detected after RC-Gate installation:  
Uninstall RC Gate. Check the machine serial number. Check if the certificate matches the NVRAM. Write the same certificate for both, and then reinstall RC Gate.

Troubleshooting

## 5.7.11 SC653-00

### Error Name

Invalid Remote Service ID2

### Type

A

### Symptoms

- The number of characters is not 17.
- The ID includes a character that cannot be printed.
- The ID is all spaces.
- The ID is NULL.

### Possible Causes

Replace the NVRAM.

### Troubleshooting Procedures

Uninstall RC Gate. Write the same certificate for both, and then reinstall RC Gate.



## 5.7.12 SC669-01 TO -26, -36, -37

### Error Name

SC669-01: EEPROM OPEN: ID Error  
SC669-02: EEPROM OPEN: Channel Error  
SC669-03: EEPROM OPEN: Device Error  
SC669-04: EEPROM OPEN: Communication Abort Error  
SC669-05: EEPROM OPEN: Communication Timeout Error  
SC669-06: EEPROM OPEN: Operation Stopped Error  
SC669-07: EEPROM OPEN: Buffer Full Error  
SC669-08: EEPROM OPEN: No Error Code  
SC669-09: EEPROM CLOSE: ID Error  
SC669-10: EEPROM CLOSE: No Error Code  
SC669-11: EEPROM Data Write: ID Error  
SC669-12: EEPROM Data Write: Channel Error  
SC669-13: EEPROM Data Write: Device Error  
SC669-14: EEPROM Data Write: Communication Abort Error  
SC669-15: EEPROM Data Write: Communication Timeout Error  
SC669-16: EEPROM Data Write: Operation Stopped Error  
SC669-17: EEPROM Data Write: Buffer Full Error  
SC669-18: EEPROM Data Write: No Error Code  
SC669-19: EEPROM Data Read: ID Error  
SC669-20: EEPROM Data Read: Channel Error  
SC669-21: EEPROM Data Read: Device Error  
SC669-22: EEPROM Data Read: Communication Abort Error  
SC669-23: EEPROM Data Read: Communication Timeout Error  
SC669-24: EEPROM Data Read: Operation Stopped Error  
SC669-25: EEPROM Data Read: Buffer Full Error  
SC669-26: EEPROM Data Read: No Error Code  
SC669-36: SRAM Data Written to EEPROM: Verification Error  
SC669-37: EEPROM Failure Detection

### Type

D

### Symptoms

- SC669-01, -07, -08, -09, -10, -11, -17, -18, -19, -25, -26  
An error occurred during EEPROM communication, but recovery failed after retrying three times.
- SC669-02, -12, -20  
An error occurred during EEPROM communication, but recovery failed after retrying three times.

This SC is detected when there is:

- arbitration loss (AL=1)
- path error (BER=1)
- ACT error
- SC669-03, -13, -21  
An error occurred during EEPROM communication, but recovery failed after retrying three times.

This SC is detected when there is no ACK after sending the slave address (FBT=1 & RACK=1).

- SC669-04, -14, -22  
An error occurred during EEPROM communication, but recovery failed after retrying three times.

This SC is detected when:

- there is no ACK after sending the slave address with the master set to write and RACK for the register of SSR/IBSR set to 1.
- stop conditions cannot be detected (SPC=1).

- SC669-05, -15, -23  
An error occurred during EEPROM communication, but recovery failed after retrying three times.

This SC is detected when there was a time-out pending interruption (start conditions are not issued).

- SC669-06, -16, -24  
An error occurred during EEPROM communication, but recovery failed after retrying three times.

This SC is detected when:

- there is an overrun error (ORE=1).
- there are other errors defined by the software designer.
- SC669-36  
An error occurred during EEPROM communication, but recovery failed after two retries.

An invalid value is detected when reading from the EEPROM data at power ON or recovery from Energy Save.

- SC669-37  
An error occurred during EEPROM communication, but recovery failed after one retry.  
An error is detected in the EEPROM at power ON or recovery from Energy Save.

#### Possible Causes

- There is noise.
- The EEPROM is defective.

#### Troubleshooting Procedures

1. Turn OFF then ON the main power.

2. **Replace the EEPROM on the BICU.**
3. **Replace the BiCU.**

### 5.7.13 SC670-01, -02

#### Error Name

SC670-01: Engine Start Up Error

SC670-02: Engine Down at Start Up (No SC Reboot)

#### Type

D

#### Symptoms

- SC670-01
  - A /ENGRDY signal was not asserted at power ON or recovery from Energy Save.
  - There is no response from the EC/PC/SC command within 70 secs after the main power was turned ON.
  - Writing onto the Rapi driver failed (the other party could not be found through PCI).
- SC670-02

After a /ENGRDY signal is asserted, there is an unexpected engine down.

#### Possible Causes

- SC670-01

The engine board failed to start up.
- SC670-02

The engine board was reset at an unexpected time.

#### Troubleshooting Procedures

1. **Check if new firmware is available for the engine and controller boards. (SC670-02 only)**
  - If there is new firmware, update the boards.
  - If there is no new firmware, proceed to the next step.
2. **Reconnect the engine board and the controller board.**

If the SC does not recur, no further action is necessary. If the SC recurs, proceed to the next step.
3. **Replace the boards in the following order.**
  - Engine board
  - Controller board, or the board between the controller and the engine
  - PSU

## 5.7.14 SC672-10 TO -13, -99

### Error Name

Controller Start Up Error

### Type

D

### Symptoms

The SC is detected when:

- the communication line between the controller and the operation panel cannot be established after power ON, or communication with the controller was cut off even though startup was successful.
- no attention code (FDH) or attention acknowledgement code (FEH) was sent from the controller within 30 secs after the power of the operation panel was turned ON or was reset.
- the operation panel sends a command to the controller once every 30 secs to check the communication line, and there was no reply from the controller for two consecutive times.

Because this SC is detected by the operation panel, it will not be logged or reported.

### Possible Causes

- The controller freezes.
- The controller board is not installed correctly.
- The controller board is malfunctioning.
- The harness of the operation panel is disconnected, or the connection is loose.
- The controller's response is slow.

### Troubleshooting Procedures

- Turn OFF then ON the main power.
- Check if the operation panel harness is properly connected.
- Check if the controller board is installed correctly,
- Replace the controller board.

## 5.7.15 SC673-10

### Error Name

Operation Panel Flair Communication Error (Smart Operation Panel)

### Type

D

### Symptoms

This SC is detected when:

- The Smart Operation Panel is communicating with the main machine (this is called “flair communication”), and there was no response from the main machine.
- SP5-748-201 for Smart Operation Panel is not enabled.

### Possible Causes

This SC is detected when the CATS module (controller) cannot respond to the notification from the monitoring service module (operation panel).

### Troubleshooting Procedures

- Turn OFF then ON the main power.
- If SP5748-201 is set to “0” (Not connect), change the value to “1” (Connect).

## 5.7.16 SC681-01, -06, -11, -16, -21, -26, -31, -36

### Error Name

SC681-01: Invalid Device ID  
 SC681-06: Channel Error  
 SC681-11: Device Error  
 SC681-16: Communication Abort Error  
 SC681-21: Communication Timeout Error  
 SC681-26: Operation Stopped Error  
 SC681-31: Buffer Full Error  
 SC681-36: Verification Error

### Type

D

### Symptoms

- SC681-01  
An error occurred during EEPROM communication, but recovery failed after retrying three times.
- SC681-06  
An error occurred during EEPROM communication, but recovery failed after retrying three times.  
This SC is detected when there is:
  - arbitration loss (AL=1)
  - path error (BER=1)
  - ACT error
- SC681-11  
An error occurred during EEPROM communication, but recovery failed after retrying three times.  
This SC is detected when there is no ACK after sending the slave address (FBT=1 & RACK=1)
- SC681-16  
An error occurred during EEPROM communication, but recovery failed after retrying three times.  
This SC is detected when:
  - there is no ACK after sending the slave address with the master set to write and RACK for the register of SSR/IBSR set to 1.
  - stop conditions cannot be detected (SPC=1)
- SC681-21  
An error occurred during EEPROM communication, but recovery failed after retrying three times.

## SC6xx (Including Controller Service Calls)

This SC is detected when there was a time-out pending interruption (start conditions are not issued).

- SC681-26

An error occurred during EEPROM communication, but recovery failed after retrying three times.

This SC is detected when:

- there is an overrun error (ORE=1).
- there are other errors defined by the software designer.

- SC681-31

Unknown

- SC681-36

An error occurred during EEPROM communication, but recovery failed after two retries.

### Possible Causes

- There is noise.
- The connection is loose.
- There is mis-operation (SC681-01, -06, -21, -26, -31).

### Troubleshooting Procedures

- Turn the main power OFF. See if the SC recurs.
- Replace the BiCU.



## 5.7.17 SC682-01, -06, -11, -16, -21, -26, -31, -36

### Error Name

SC682-01: TD Sensor Communication Error: Invalid Device ID

SC682-06: TD Sensor Communication Error: Channel Error

SC682-11: TD Sensor Communication Error: Device Error

SC682-16: TD Sensor Communication Error: Communication Abort Error

SC682-21: TD Sensor Communication Error: Communication Timeout Error

SC682-26: TD Sensor Communication Error: Operation Stopped Error

SC682-31: TD Sensor Communication Error: Buffer Full Error

SC682-36: TD Sensor Communication Error: Verification Error

### Type

D

### Symptoms

- SC682-01  
An error occurred during EEPROM communication, but recovery failed after retrying three times.
- SC682-06  
An error occurred during EEPROM communication, but recovery failed after retrying three times.  
This SC is detected when there is:
  - arbitration loss (AL=1)
  - path error (BER=1)
  - ACT error
- SC682-11  
An error occurred during EEPROM communication, but recovery failed after retrying three times.  
This SC is detected when there is no ACK after sending the slave address (FBT=1 & RACK=1).
- SC682-16  
An error occurred during EEPROM communication, but recovery failed after retrying three times.  
This SC is detected when:
  - there is no ACK after sending the slave address with the master set to write and RACK for the register of SSR/IBSR set to 1 (RACK=1).
  - stop conditions cannot be detected (SPC=1).
- SC682-21  
An error occurred during EEPROM communication, but recovery failed after retrying three times.

## SC6xx (Including Controller Service Calls)

This SC is detected when there was a time-out pending interruption (start conditions are not issued).

- SC682-26

An error occurred during EEPROM communication, but recovery failed after retrying three times.

This SC is detected when:

- there is an overrun error (ORE=1).
- there are other errors defined by the software engineer.

- SC682-31

Unknown

- SC682-36

An error occurred during EEPROM communication, but recovery failed after two retries.

### Possible Causes

- There is noise.
- The connection is loose.
- There is mis-operation (SC682-01, -06, -21, -26, -31).

### Troubleshooting Procedures

- Turn the main power OFF. See if the SC recurs.
- Replace the BiCU.

## 5.7.18 SC687-00

### Error Name

Memory Address Error

### Type

D

### Symptoms

After an RAPI-PES (request for preparation for image transfer) is sent, there was no RAPI-PER (preparation for image transfer completed) from the controller within the specified period of time (120 secs).

### Possible Causes

- There is noise.
- The controller board is malfunctioning.

### Troubleshooting Procedures

- Turn OFF then ON the main power.
- Replace the controller board.
- Check if new firmware is available for the engine and controller boards.
  - If there is new firmware, update the boards. Turn OFF then ON the main power, and see if the SC recurs.
  - If there is no new firmware, proceed to the next step.
- Check the mode when the SC occurred.
  - Printer or Fax (Receiving) modes: Replace the controller board.
  - Copier mode: Check the connections of the scanner-related paths (from the ARDF to the BiCU).

SC7xx

## 5.8 SC7XX

SC7xx is not used at this time.

## 5.9 SC8XX

### 5.9.1 SC816-00 TO -96, -99

#### Error Name

SC816-00: Energy Save I/O Subsystem Failure Detection  
 SC816-01: Energy Save I/O Subsystem Error  
 SC816-02, -07, -10, -11, -12: Energy Save I/O Subsystem Error: sysarch (LPUX\_GET\_PORT\_INFO) Error  
 SC816-03: Energy Save I/O Subsystem Error: STR Transition Failure  
 SC816-04: Energy Save I/O Subsystem Error: Kernel Communication Driver Interruption  
 SC816-05, -06: Energy Save I/O Subsystem Error: Preparation for STR Transition Failed  
 SC816-08: Energy Save I/O Subsystem Error: sysarch ( LPUX\_ENGINE\_TIMERCTRL) Error  
 SC816-09: Energy Save I/O Subsystem Error: sysarch (LPUX\_RETURN\_FACTOR\_STR) Error  
 SC816-13, -15 to -18, -20: Energy Save I/O Subsystem Error: Open () Error  
 SC816-14: Energy Save I/O Subsystem Error: Memory Address Error  
 SC816-19: Energy Save I/O Subsystem Error: Double Open () Error  
 SC816-22: Energy Save I/O Subsystem Error: Parameter Error  
 SC816-23, -24, -35: Energy Save I/O Subsystem Error: Read () Error  
 SC816-25: Energy Save I/O Subsystem Error: Write () Error  
 SC816-26, -27, -28: Energy Save I/O Subsystem Error: Write () Communication Retry Error  
 SC816-29, -30: Energy Save I/O Subsystem Error: Read () Communication Retry Error  
 SC816-36 to -99: Energy Save I/O Subsystem Error: Subsystem Error

#### Type

D

#### Symptoms

The Energy Save I/O Subsystem has detected an error.

#### Possible Causes

- The Energy Save I/O Subsystem itself is malfunctioning.
- The Energy Save I/O Subsystem detects a controller board error (no response).
- An error was detected during preparation for transition to STR.

#### Troubleshooting Procedures

Generally, these are fatal errors.

Turn OFF then ON the main power. If the problem is not solved, there is a problem with the hardware. Replace the controller board.

## 5.9.2 SC817-00

### Error Name

Monitor Error: File Detection/Digital Signature Error

### Type

D

### Symptoms

- The bootloader failed to read the diagnostic module, kernel, or root file system.
- The digital signature of the bootloader SD card with a diagnostic module, kernel, or root file system cannot be checked.

### Possible Causes

- The diagnostic module, kernel, or root file system in the SD card does not exist or is corrupted.
- The diagnostic module, kernel, or root file system in the SD card was tampered with.

### Troubleshooting Procedures

- Update the ROM of the controller system.
- Use a bootloader SD card that has a valid digital signature.

## 5.9.3 SC818-00

### Error Name

Watchdog Violation Error

### Type

D

### Symptoms

A watchdog violation error is detected.

### Possible Causes

The bus or the interruption program goes into an endless loop, causing other processes to stop.

### Troubleshooting Procedures

- Turn OFF then ON the main power.
- Replace the system program.
- Replace the controller board.
- Replace the peripherals.

## 5.9.4 SC819-00 [0X5032]

### Error Name

Kernel Halt: HAIC-P2 Error

### Type

D

### Symptoms

An error has occurred in the HAIC-P2 (the compression/decompression module in the ASIC).

### Possible Causes

- If EFI controller is installed:  
When HAIC-P2 compression/decompression data is sent from the EFI controller to the GW controller, a decoding error (P2ERR) occurred due to a flaw in the data.  
In such a case, check with EFI.  
The types of P2ERR errors are as follows:
    - T-ERR (Terminal Error): This error
    - H-ERR (Code Error): Unlikely to occur because an IP is sent.
    - L-ERR (Incorrect Line Length): The contents that were verified during the combined debug with EFI.
  - If EFI controller is not installed:
    - The code data in the HDD is corrupted for some reason (for example, the HDD is defective).
    - The code data in the NVRAM is corrupted for some reason (for example, the memory is defective).
    - The ASIC is defective.
    - Due to a fault in the software, data other than the code data is decompressed.
- If the problem cannot be solved by replacing the hardware, check with IMH.

### Troubleshooting Procedures

- Turn OFF then ON the main power.
- Replace the HDD.
- Replace the NVRAM.
- Replace the controller board.
- Amend the software.



## 5.9.5 SC819-00 [0X6261], [0X696E], [0X766D], [554C], OTHERS

### Error Name

- SC819-00 [0x6261]: Kernel Halt: HDD Error
- SC819-00 [0x696e]: Kernel Halt: gwinit Processing End
- SC819-00 [0x766d]: Kernel Halt: VM Full
- SC819-00 [554C]: Kernel Halt: mips Models SATA Loader Stopped
- SC819-00 (Character string displayed): Kernel Halt: Others

### Type

D

### Symptoms

- [0x6261]  
There is no error reply from the HDD. Even though initialization was successful, the file system data received is corrupted.
- [0x696e], [0x766d]  
Unknown
- [554C]  
A discrepancy is detected in the SATA loader.
- (Character string displayed)  
There is a discrepancy in the OS.

### Possible Causes

- [0x6261]  
A sudden cut in the power supply when writing data to the HDD.
- [0x696e]  
If the SCS process ends for some reason, the gwinit process will also end (this is in accordance with gwinit specifications). As a result, the kernel will also come to a halt (this is in accordance with kernel specifications).
- [0x766d]  
Too much RAM is used during system processing.
- [554C]  
Unknown
- (Character string displayed)
  - There is a bug in the software.
  - There is insufficient memory.
  - The hardware (RAM, FLASH memory, CPU) is malfunctioning.

### Troubleshooting Procedures

- [0x6261]  
Replace or remove the HDD.
- [0x696e], [0x766d]

Nil

- [554C]  
Replace the controller board.
- (Character string displayed)
  - When there is a software bug, identify the conditions causing the bug, and contact the software engineer.
  - When there is insufficient memory, replace with an expanded memory.

## 5.9.6 SC820-00 [XXXX]

### Error Name

SC820-00: Self-diagnostic Errors (CPU)

[0001]: TLB Change (Store) Exception Error

[0002]: TLB Miss (Load) Exception Error

[0003]: TLB Miss (Store) Exception Error

[0004], [0601]: Read Address Exception Error

[0005], [0602]: Write Address Exception Error

[0006]: Instruction Bus Exception Error

[0007]: Data Bus Exception Error

[0008], [0605]: System Call Exception Error

[0009], [0606]: Break Exception Error

[000A], [0607]: Invalid Instruction Exception Error

[000B]: Co-processor Exception Error

[000C], [0609]: Overflow Exception Error

[000D]: UTLB Miss Exception Error

[0010] to [0015]: Interrupt Lines 0 to 5 Error

[00FF]: Uninitialized Interrupt Error

[060A] to [060E]: Interrupt Lines 0 to 4 Mask Exception Error

[0610]: CPU Interrupt Timer 2 Set Error

[0612]: ASIC Interrupt Error

[06FF]: CPU Master Clock Error

[0701]: Instruction Cache Capacity Error

[0702]: Instruction Cache Error

[0703]: Instruction Uncache Error

[0704]: Instruction Cache Hit Error

[0705]: Instruction Cache Clear Error

[0706]: Data Cache Size Error

[0707]: Data Cache Error

[0708]: Data Uncache Error

[0709]: Data Cache Hit Error

[070A]: Data Cache Clear Error

[0801]: TLB Virtual Address Error

[0804]: TLB Global Error

[0807]: UTLB Miss Error

[0808]: TLB Read Miss Error

[0809]: TLB Write Miss Error

[080A]: TLB Modify Error

[4002]: Single Precision Arithmetic Error

[4003]: Double Precision Arithmetic Error

[4004]: Exception Error

[4005]: Exception Mask Error

### Type

C

### Symptoms

[001] to [0015], [000A], [000B], [000C], [000D]	There is an unexpected exception or interruption.
[00FF]	There is a cache parity error.
[0601], [0602], [0605], [0606], [0607], [0609]	An exception did not occur even though there was an instruction to deliberately generate an exception.
[060A], [060B], [060C], [060D], [060E]	An interruption did not occur even though interruption was set using the timer.
[0610]	An interruption did not occur even though t $\tau$ CPU timer interruption was specified.
[0612]	An interruption occurred in the ASIC.
[06FF]	The frequency ratio of the CPU's pipeline clock is different from the specified value.
[0701]	A cache error occurred because only the command cache size is written into the CPU's primary instruction cache. In the case of VR series (by NEC) and RM series (by QED), a check will not be conducted because this function is not supported.
[0702]	A program was executed in the instruction cache, but the result was different from expected.
[0703], [0704], [0705]	Only the command cache size is set in the CPU's primary instruction cache, and a difference is detected when the instruction cache is retrieved. In the case of VR series (by NEC) and RM series (by QED), checking will not be done because this function is not supported.

[0706], [0707], [0708]	<p>Only the command cache size is set in the CPU's primary data cache, and a difference is detected when the instruction cache is retrieved.</p> <p>In the case of VR series (by NEC) and RM series (by QED), checking will not be done because this function is not supported.</p>
[0709], [070A]	Even though data was written to only the cache area, the non-cache areas were also updated.
[0801], [0804], [0807], [0808], [0809], [080A]	An error occurred during TLB checking.
[4002], [4003], [4004], [4005]	An error occurred when the floating-point coprocessor in the CPU was making a calculation.

### Possible Causes

[0001] to [0015], [000A], [000B], [000C], [000D]	<ul style="list-style-type: none"> <li>▪ The CPU is defective.</li> <li>▪ The boot monitor program or self-diagnostic program is damaged.</li> </ul>
[00FF]	<ul style="list-style-type: none"> <li>▪ The CPU is defective.</li> <li>▪ The local bus is defective.</li> </ul>
[0601], [0602], [0605], [0606], [0607], [0609], [0610], [0801], [0804], [0807], [0808], [0809], [080A], [4002] to [4005]	The CPU is defective.
[060A], [060B], [060C], [060D], [060E]	<ul style="list-style-type: none"> <li>▪ The CPU is defective.</li> <li>▪ The ASIC is defective.</li> </ul>
[0612]	<ul style="list-style-type: none"> <li>▪ The ASIC is defective.</li> <li>▪ The peripherals are defective.</li> </ul>
[06FF]	<ul style="list-style-type: none"> <li>▪ The CPU is defective.</li> <li>▪ The module bit data used to initialize the CPU is invalid.</li> </ul>

[0701], [0703], [0704], [0705], [0706], [0707], [0708]	Unknown
[0702]	<ul style="list-style-type: none"> <li>▪ The cache of the CPU is corrupted.</li> <li>▪ The memory is too slow.</li> </ul>
[0709], [070A]	<ul style="list-style-type: none"> <li>▪ The CPU is defective.</li> <li>▪ The SPD of the memory is invalid (for example, the SPD contains data for a fast device, but it was a slow device).</li> </ul>

### Troubleshooting Procedures

[0001] to [0015], [000A], [000B], [000C], [000D]	<ul style="list-style-type: none"> <li>▪ Replace the controller board.</li> <li>▪ Reinstall the boot monitor program or self-diagnostic program.</li> </ul>
[00FF]	<ul style="list-style-type: none"> <li>▪ Turn OFF then ON the main power.</li> <li>▪ Reinstall the controller system program.</li> <li>▪ Replace the controller board.</li> <li>▪ Replace the peripherals.</li> </ul>
[0601], [0602], [0605], [0606], [0607], [0609], [060A], [060B], [060C], [060D], [060E], [0610], [06FF], [0801], [0804], [0807], [0808], [0809], [080A], [4002], [4003], [4004], [4005]	Replace the controller board.
[0612]	<ul style="list-style-type: none"> <li>▪ Replace the controller board.</li> <li>▪ Replace the peripherals.</li> </ul>
[0701], [0703], [0704], [0705], [0706], [0707], [0708]	Nil
[0702], [0709], [070A]	<ul style="list-style-type: none"> <li>▪ Replace the controller board.</li> <li>▪ Replace the memory.</li> </ul>

## 5.9.7 SC821-00 [XXXX]

### Error Name

SC821-00: Self-diagnostic Errors (ASIC)

[0B00]: ASIC Register Check Error

[0B06]: ASIC Detection Error

[0D05]: ASIC and CPU Timer Comparison Error

[50A1]: Video Bridge Device Detection Error

[50A2]: Video Bridge Device Register Error

### Type

D

### Symptoms

- [0B00]  
A write-and-verify check error has occurred in the system control ASIC (the main ASIC on the controller board that is used to control buses such as ROM devices).
- [0B06]  
The system control ASIC cannot be detected.
- [0D05]  
The comparison between the ASIC interrupt timer and the CPU interrupt timer does not fall within the specified range.
- [50A1]  
The video bridge device cannot be detected.
- [50A2]  
A verify error occurred with a particular register in the video bridge.

### Possible Causes

- [0B00]  
The ASIC is defective.
- [0B06]
  - The system control ASIC is defective.
  - North Bridge and PCII/F are defective.
- [0D05]
  - The ASIC timer device is defective.
  - The CPU is defective.
- [50A1], [50A2]
  - The video bridge ASIC (HARP or KLAVIER) is defective.
  - The I/F between the controller ASIC and the video bridge ASIC is defective.

### Troubleshooting Procedures

Replace the controller board.



## 5.9.8 SC822-00 [XXXX]

### Error Name

SC822-00: Self-diagnostic Errors (HDD)

[3003]: HDD Timeout Error

[3004]: Diagnostic Command Error

[3013]: HDD Timeout Error (First Machine)

[3014]: Diagnostic Command Error (First Machine)

### Type

D

### Symptoms

- [3003], [3013]
  - The BSYbit of the HDD does not shutdown even though 31 secs have elapsed (busy).
  - The BSYbit does not shutdown even though 6 secs have elapsed after a diagnostic command is set for the HDD.
- [3004], [3014]

A diagnostic command was sent to the HDD but there was no response.

### Possible Causes

- [3003], [3013]
  - The HDD is defective.
  - The HDD connector is defective.
- [3004], [3014]

The HDD is defective.

### Troubleshooting Procedures

- [3003], [3013]
  - Replace the HDD.
  - Replace the HDD connector.
  - Replace the controller board.
- [3004]

Replace or remove the HDD.
- [3014]

Replace the HDD.

## 5.9.9 SC823-00 [XXXX]

### Error Name

SC823-00: Self-diagnostic Errors (NIC)

[6101]: MAC Address Check Sum Error

[6104]: Invalid PHY Chip ID

[6105]: PHY Loop-back Error

### Type

B

### Symptoms

- [6101]
  - The MAC address check sum in the SEEP ROM does not match the stored check sum.
  - The MAC address format in the SEEP ROM is different.
- [6104]

The OUI in the MII ID register (PHYIDR1, PHYIDR2) of the PHY chip was not of the specified manufacturer.
- [6105]

An error was detected when conducting a loop-back on the PHY chip.

### Possible Causes

- [6101]
  - The SEEP ROM is defective.
  - The I2C bus is not properly connected.
- [6104]
  - The PHY chip is defective.
  - The I/F of the ASIC MII is defective.
- [6105]
  - The PHY chip is defective.
  - The MAC of the ASIC (SIMAC/COMIC/CELLO) is defective.
  - The I/F of the PHY board is defective (if it is installed).
  - The solder on the PHY board is defective (if it is installed).

### Troubleshooting Procedures

- [6101]
  - Replace the PHY board (if it is installed).
  - Replace the controller board.
- [6104]

Nil
- [6105]
  - Check the I/F of the PHY board (if it is installed) and the controller board.

- Replace the PHY board (if it is installed).
- Replace the controller board.

### 5.9.10 SC824-00 [1401]

#### Error Name

Self-diagnostic Error (NVRAM (Resident)): NVRAM Verify Error

#### Type

C

#### Symptoms

- The NVRAM is missing.
- The NVRAM is damaged.

#### Possible Causes

- The NVRAM is defective.
- The backup battery has run out (in the case of an NVRAM with RTC).
- The NVRAM socket is loose.

#### Troubleshooting Procedures

Replace the NVRAM.

## 5.9.11 SC827-00 [0201], [0202]

### Error Name

SC827-00: Self-diagnostic Errors (RAM)

[0201]: Resident Memory Verify Error

[0202]: Structural error in the resident memory

### Type

D

### Symptoms

- [0201]  
An error has occurred during a write-and-verify check of the RAM on the controller board. (The standard RAM on the controller board is made up of 1GB of resident RAM and 1GB of the optional RAM).
- [0202]  
All the SPD values of the RAM DIMM are wrong, or they cannot be retrieved.

### Possible Causes

- [0201]  
The memory is defective.
- [0202]
  - The RAM DIMM does not match the specifications of the ASIC.
  - The SPD ROM on the RAM DIMM is defective.
  - The I2C bus is defective.

### Troubleshooting Procedures

- [0201]  
Replace the controller board (for machines with no resident RAM, replace the RAM-DIMM).
- [0202]  
Replace the RAM DIMM (replace the controller board).

## 5.9.12 SC828-00 [0101]

### Error Name

Self-diagnostic Error (ROM): Bootstrap Code Error

### Type

D

### Symptoms

The CRC is calculated for the boot monitor and the OS program, and an error is detected when the result is different from expected. However, checking is not done for card boot.

### Possible Causes

- The flash ROM in the boot monitor, self-diagnostic program, or the OS program is corrupted or has deteriorated.
- The CPU is defective.

### Troubleshooting Procedures

- Reinstall the boot monitor, self-diagnostic program, or OS program.
- Replace the controller board.

### 5.9.13 SC829-00 [XXXX]

#### Error Name

SC829-00: Self-diagnostic Errors (Optional RAM)

[0301]: Optional Memory 0 Verify Error

[0302]: Optional Memory 0 Structural Error

[0401]: Optional Memory 1 Verify Error

[0402]: Optional Memory 1 Structural Error

#### Type

D

#### Symptoms

- [0301]
  - For machines with resident RAM, Optional Memory 0 refers the RAM DIMM installed in the RAM Slot.
  - For machines without resident RAM, Optional Memory 0 refers to the RAM DIMM installed in Slot 0.

This error does not occur with machines that do not have resident RAM.

- [0302]

Every time the main power is turned ON, the structure of the optional RAM is checked. If an error is detected at this point, the self-diagnostic module will not check the optional RAM.
- [0401]

The standard RAM is made up of 1GB of resident RAM and 1GB of the optional RAM.
- [0402]

Every time the main power is turned ON, the structure of the optional RAM is checked. If an error is detected at this point, the self-diagnostic module will not check the optional RAM.

(The standard RAM is made up of 1GB of resident RAM and 1GB of the optional RAM.)

#### Possible Causes

- [0301]

The memory is defective.
- [0302], [0402]

Unknown
- [0401]

The memory is defective.

#### Troubleshooting Procedures

- [0301]

Replace the controller board (for machines with no resident RAM, replace the RAM-DIMM).

- [0302], [0402]  
Nil
- [0401]  
Replace the controller board.

### 5.9.14 SC833-00 [0F30], [50B1], [50B2]

#### Error Name

SC833-00: Self-diagnostic Errors (Engine I/F ASIC)

[0F30]: Engine I/F ASIC Detection Error

[50B1]: Video Device Clock Generator Detection Error

[50B2]: Video Device Clock Generator Verify Error

#### Type

D

#### Symptoms

- [0F30]  
The ASIC for engine control (Mandolin) cannot be detected.
- [50B1]  
Unable to initialize or read the bus connection.
- [50B2]  
The value of the SSCG register is not correct.

#### Possible Causes

- [0F30]  
The ASIC for engine control (Mandolin) is defective.
- [50B1]  
The connection bus or SSCG is defective.
- [50B2]  
The connection bus or SSCG is defective.

#### Troubleshooting Procedures

Replace the engine I/F board (motherboard).



### **5.9.15 SC834-00 [5101]**

**Error Name**

Self-diagnostic Errors (Engine I/F ASIC): Optional Memory: Engine I/F Optional Memory  
Verify Error

**Type**

D

**Symptoms**

An error has occurred during a write-&-verify check of the optional RAM on the engine I/F board (motherboard).

**Possible Causes**

The memory is defective.

**Troubleshooting Procedures**

Replace the engine I/F board (motherboard).

## 5.9.16 SC835-00 [1102], [110C], [1120]

### Error Name

SC835-00: Self-diagnostic Errors (Centronics Device)

[1102]: Verify Error

[110C]: DMA Verify Error

[1120]: Loopback Connector Detection Error

### Type

B

### Symptoms

- [1102]  
A connection error is detected even though the loopback connector is connected.
- [110C]  
An error is detected in the DMA data even though the loopback connector is connected.
- [1120]  
The centronics loopback connector is not connected for the detailed self-diagnostic test.

### Possible Causes

- [1102]
  - The IEEE 1284 connector is defective.
  - The loopback connector is defective.
- [110C]
  - The ASIC is defective.
  - The IEEE1284 connector is defective.
  - The loopback connector is defective.
- [1120]
  - The centronics loopback connector is not connected.
  - The centronics loopback connector is defective.
  - The centronics loopback connector terminal is defective.
  - The ASIC is defective.

### Troubleshooting Procedures

- [1102], [110C]  
Replace the controller board.
- [1120]
  - Reconnect the centronics loopback connector.
  - Replace the centronics loopback connector.
  - Replace the controller board.

### **5.9.17 SC838-00 [2701]**

**Error Name**

Self-diagnostic Error (Clock Generator): Verify Error

**Type**

C

**Symptoms**

The setting data retrieved by the clock generator via the I2C bus is not correct.

**Possible Causes**

- The clock generator is defective.
- The I2C bus is defective.
- The I2C bus port on the CPU is defective.

**Troubleshooting Procedures**

Replace the controller board.

### **5.9.18 SC839-00 [9001]**

**Error Name**

Self-diagnostic Error (Serial Flash): Serial Flash Access Error

**Type**

D

**Symptoms**

An error occurred when reading the Software Status Register from the serial Flash or writing the Software Status Register to the serial Flash.

**Possible Causes**

The serial Flash is defective.

**Troubleshooting Procedures**

Replace the controller board.

### 5.9.19 SC840-00

**Error Name**

EEPROM Access Error

**Type**

D

**Symptoms**

- A reading error occurred during I/O processing, and after three subsequent retries reading still failed.
- A writing error occurred during I/O processing.

**Possible Causes**

The EEPROM is defective.

**Troubleshooting Procedures**

Nil

### 5.9.20 SC841-00

**Error Name**

EEPROM Read Data Error

**Type**

D

**Symptoms**

Mirrored data of the EEPROM is different from the original data in EEPROM.

**Possible Causes**

Data in the EEPROM is overwritten for some reason.

**Troubleshooting Procedures**

Nil

## 5.9.21 SC842-00, -02

### Error Name

SC842-00: Nand-Flash Verification Error

SC842-01: Nand-Flash Block Threshold Over Error

SC842-02: Nand-Flash Block Deletion Over Error

### Type

C

### Symptoms

- SC842-00  
During remote ROM update or ROM update, the SCS detected a write error (verify error) regarding the data written to the Nand-Flash.
- SC842-01  
At startup or recovery from Energy Save, the Nand-Flash status is read and the number of unusable blocks exceeded the threshold.
- SC842-02  
At startup or recovery from Energy Save, the Nand-Flash status is read and the number of deleted blocks exceeded the threshold.

### Possible Causes

- SC842-00  
Nand-Flash is damaged.
- SC842-01  
The number of unusable blocks have exceeded the threshold.
- SC842-02  
The number of deleted blocks have exceeded the threshold.

### Troubleshooting Procedures

Turn OFF then ON the main power.

Replace the controller board.

## 5.9.22 SC845-01 TO -05

### Error Name

Hardware Error during Firmware Auto Update

### Type

D

### Symptoms

Cannot complete firmware update while retrying three times.

### Possible Causes

Hardware-related error occurs in a board.

The branch number of this SC represents where the error occurs.

-01: BiCU

-02: Controller Board

-03 or -04: Operation panel board

-05: FCU

### Troubleshooting Procedures

Replace the board that causes the SC.

## 5.9.23 SC853-00

### Error Name

Bluetooth Device Connection Error

### Type

D

### Symptoms

Bluetooth (USB) option is connected when the main power is ON.

### Possible Causes

Bluetooth (USB) option cannot be connected while the main power is ON.

### Troubleshooting Procedures

Turn ON the main power after the option is connected to the USB port.

## 5.9.24 SC850-00

### Error Name

Network I/F Error

### Type

D

This error is specified but cannot be operated.

### **5.9.25 SC854-00**

**Error Name**

Bluetooth Device Disconnection

**Type**

B

**Symptoms**

The Bluetooth hardware (USB type) was removed after startup.

**Possible Causes**

The Bluetooth hardware (USB type) was removed after startup.

**Troubleshooting Procedures**

Connect the Bluetooth hardware (USB type) before turning ON the main power.

### **5.9.26 SC857-00**

**Error Name**

USB I/F Error

**Type**

B

**Symptoms**

A driver error has occurred and the USB I/F cannot be used.

**Possible Causes**

An error has occurred in the USB driver.

There are three causes for USB driver error: RX error, CRC error, and STALL. This SC is detected only for STALL.

**Troubleshooting Procedures**

- Check the USB connection.
- Replace the controller board.

## 5.9.27 SC858-00, -01, -02, -30, -31

### Error Name

SC858-00: Data Encryption Conversion Error (Key Acquisition Error)

SC858-01: Data Encryption Conversion Error (HDD Key Setting Error)

SC858-02: Data Encryption Conversion Error (NVRAM Read/Write Error)

SC858-30: Data Encryption Conversion Error (NVRAM Before Conversion Error)

SC858-31: Data Encryption Conversion Error (Other Errors)

### Type

A

### Symptoms

A serious error occurred after data conversion when updating the encryption key.

### Possible Causes

- SC858-00, -01
  - Data such as the USB Flash is corrupted.
  - A communication error is caused by electrostatic noise.
  - The controller board is defective.
- SC858-02  
The NVRAM is defective.
- SC858-30  
There is a software error (for example, the parameters used for conversion are invalid).
- SC858-31  
The controller board is defective.

### Troubleshooting Procedures

- SC858-00, -31  
Replace the controller board.
- SC858-01, -30  
Turn OFF then ON the main power.  
If the error persists, replace the controller board.
- SC858-02
  - Replace the NVRAM.
  - Replace the controller board.



## 5.9.28 SC859-00, -01, 02, -10

### Error Name

SC859-00: Data Encryption Conversion HDD Conversion Error

SC889-01: Data Encryption Conversion HDD Conversion Error (HDD Check Error)

SC859-02: Data Encryption Conversion HDD Conversion Error (Power Failure During Conversion)

SC859-10: Data Encryption Conversion HDD Conversion Error (Data Read/Write Command Error)

### Type

B

### Symptoms

- SC859-00, -01  
When updating the data encryption key, HDD data was not converted correctly. During conversion, only the error screen is displayed and there is no SC. The SC is displayed after the machine is turned OFF and ON.
- SC859-02  
When updating the data encryption key, NVRAM/HDD conversion was incomplete. During conversion, only the error screen is displayed and there is no SC. The SC is displayed after the machine is turned OFF and ON.
- SC859-10  
When updating the data encryption key, an abnormal DMAC return value (such as DMAC time-out or serial communication error) was detected for two or more times. During data conversion, only the error screen is displayed and there is no SC. The SC is displayed after the machine is turned OFF and ON.

### Possible Causes

- SC859-00, -01
  - HDD conversion was specified for data encryption key update, but the HDD was removed.
  - Power was cut during data encryption key update.
  - There was a HDD error or electrostatic noise during data encryption key update.
- SC859-02  
Power was cut during data encryption key update.
- SC859-10  
There was a HDD error or electrostatic noise during data encryption key update.

### Troubleshooting Procedures

- SC859-00, -01, -10
  - Check the HDD connection.
  - Format the HDD.

- If the HDD is defective, replace it.
- SC859-02  
After restart, a screen instructing the user to format the HDD is displayed.

## 5.9.29 SC860-00

### Error Name

HDD Startup Error At Main Power On (HDD Error)

### Type

B

### Symptoms

- The HDD is connected but the driver detected the following errors:
  - SS\_NO.T\_READY:/\* (-2)HDD does not become READY\*/
  - SS\_BAD\_LABEL:/\* (-4)Wrong partition type\*/
  - SS\_READ\_ERROR:/\* (-5)Error occurred while reading or checking the label\*/
  - SS\_WRITE\_ERROR:/\* (-6) Error occurred while writing or checking the label\*/
  - SS\_FS\_ERROR:/\* (-7) Failed to repair the file system\*/
  - SS\_MOUNT\_ERROR:/\* (-8) Failed to mount the file system\*/
  - SS\_COMMAND\_ERROR:/\* (-9) Drive not responding to command\*/
  - SS\_KERNEL\_ERROR:/\* (-10) Internal kernel error\*/
  - SS\_SIZE\_ERROR:/\* (-11) Drive size too small\*/
  - SS\_NO\_PARTITION:/\* (-12) The specified partition does not exist\*/
  - SS\_NO\_FILE:/\* (-13) Device file does not exist\*/
- The driver attempted to acquire the HDD status but there was no response.

### Possible Causes

- The HDD is not formatted.
- The label data is damaged.
- The HDD is defective.

### Troubleshooting Procedures

Format the HDD (done through SP mode).

### 5.9.30 SC862-00

**Error Name**

Bad Sector: MAX (HDD Rrror)

**Type**

B

**Symptoms**

There are 101 bad sectors in HDD

**Possible Causes**

SC863 is issued during reading HDD because of a bad sector. Then SC 862 is issued when the bad sector count reaches 101.

**Troubleshooting Procedures**

Format the HDD (SP4-911-002).

(Replacing the HDD should be performed)

### 5.9.31 SC863-00

**Error Name**

HDD Data Read Error

**Type**

B

**Symptoms**

Data in HDD cannot be read correctly.

**Possible Causes**

There is a bad sector in the HDD.

**Troubleshooting Procedures**

1. Turn OFF then ON the main power.
2. Format the HDD through SP mode.
3. Replace the HDD if:
  - this SC occurs more than 10 times.
  - this SC occurs in a short time interval.
  - it takes 30 seconds to finish the start-up.

## 5.9.32 SC863-01, -02 TO -23

### Error Name

HDD Data Read Error

### Type

D

### Symptoms

HDD data cannot be read.

### Possible Causes

- SC863-01  
A bad sector was generated during operation. (An error occurred in an area that does not belong to a partition, such as the disk label area.)
- SC863-02 to -23  
A bad sector was generated during operation. (An error occurred in partitions from “a” (SC863-02) to “v” (SC863-23).

### Troubleshooting Procedures

Replace the HDD when:

- this SC occurred ten times or more, and
- the error recurs at short intervals.
- the SC repeatedly occurs in the same situation (for example, at power ON).
- startup takes a long time when the main power is turned ON.

It takes a long time for the operation panel to become ready after power ON because it takes time to access the HDD. Normally, HDD access after power ON takes about 5 secs. If the machine is not waiting for the engine to be ready and it still takes 20 to 30 seconds or more, there may be a problem with the HDD. Check if HDD-related SCs such as SC860 and SC863 are also occurring frequently. Print the SC log data to check them.

### 5.9.33 SC864-01, -02 TO -23

#### Error Name

HDD Data CRC Error

#### Type

D

#### Symptoms

During HDD operation, the HDD did not respond to a CRC error query.

#### Possible Causes

- SC864-01  
A bad sector was generated during operation. (An error occurred in an area that does not belong to a partition, such as the disk label area.)
- SC864-02 to -23  
A bad sector was generated during operation. (An error occurred in partitions from “a” (SC863-02) to “v” (SC863-23).

#### Troubleshooting Procedures

- Format the HDD.
- Replace the HDD.

### 5.9.34 SC865-00, -01, -02 TO -23, -50 TO -73

#### Error Name

SC865-00, -01, -02 to -23: HDD Access Error

SC865-50 to -73: HDD Access Timeout Error

#### Type

D

#### Symptoms

- SC865-00, -01, -02 to -23  
During HDD operation, the HDD returned an error.
- SC865-50 to -73  
There was no response from the HDD (time-out). The area where the error occurred is unknown.

#### Possible Causes

- SC865-00  
The HDD returned an error that does not constitute SC863 (bad sector) or SC864 (CRC error).
- SC865-01  
The HDD returned an error that does not constitute SC863 (bad sector) or SC864 (CRC error). (An error occurred in an area that does not belong to a partition, such as the disk label area.)
- SC865-02 to -23  
The HDD returned an error that does not constitute SC863 (bad sector) or SC864 (CRC error). (An error occurred in partitions from “a” (SC863-02) to “v” (SC863-23).)
- SC865-50 to -73  
The HDD did not respond to the read/ write command from the machine (DMA transfer).

#### Troubleshooting Procedures

- SC865-00, -01, -02 to -23  
Replace the HDD.
- SC865-50 to -73  
Check if the HDD power cord and communication cable are properly connected.  
If the problem is not solved after reconnecting the cord or cable, replace the HDD.

### **5.9.35 SC866-00**

**Error Name**

SD Card Authentication Error

**Type**

B

**Symptoms**

An error has occurred with the license used for the electronic authentication of an application in the SD card.

**Possible Causes**

The program data in the SD card is invalid.

**Troubleshooting Procedures**

Store a valid program in the SD card.

### **5.9.36 SC867-00 TO -02**

**Error Name**

SD Card Removed Error

**Type**

D

**Symptoms**

The application SD card was removed.

**Possible Causes**

The application SD card was removed from the slot (mount point: /mnt/sd\*).

SC867-00: /mnt/sd0

SC867-01: /mnt/sd1

SC867-02: /mnt/sd2

**Troubleshooting Procedures**

Turn the main power OFF then ON.

## 5.9.37 SC868-00, -02

### Error Name

SD Card Access Error

### Type

D

### Symptoms

During operation, the SD controller returned an error. (An error occurred at mount point: /mnt/sd0).

#### Note

- The slot number is displayed in the sub code. The detailed code is on the SMC Print, and provides details about the error.
- -2, or no code number refers to device access error.

### Possible Causes

- The SD card is defective.
- The SD controller is defective.

### Troubleshooting Procedures

- In the case of an application SD Card:
  1. Turn the main power OFF. Check that the SD card is properly inserted.
  2. Turn the main power ON.
  3. If a SC is detected, replace the SD card.
  4. If the SC recurs, replace the controller board.
- In the case of an application SD Card;  
If it is a file system error, reformat the SD card (using the specified SD formatter).  
If it is a device access error, perform the following procedure.
  1. Turn the main power OFF. Check that the SD card is properly inserted.
  2. Turn the main power ON.
  3. If a SC recurs, replace with another user SD card.
  4. If the SC recurs, replace the controller board.

#### Important

- Do not format the SD card that comes with the machine, or the optional SD card. Only format the SD card used by the SE for tasks such as updating.



### 5.9.38 SC870-00 TO -60

#### Error Name

These are Address Book Data errors.

SC870-00: Anytime: Address Book Error

SC870-01: Startup: Media required for storing the Address Book is missing

SC870-02: Startup: Encryption is configured but the module required for encryption (DESS) is missing

SC870-03: Initialization: Failed to generate a file for storing the Address Book in the machine

SC870-04: Initialization: Failed to generate a file for storing Senders

SC870-05: Initialization: Failed to generate a file for storing Send Destinations

SC870-06: Initialization: Failed to generate a file for storing information needed for searching LDAP

SC870-07: Initialization: Failed to initialize entries for the system

SC870-08: Machine Configuration: There is a HDD but the area for storing the Address Book cannot be used

SC870-09: Machine Configuration: The NVRAM area for storing settings needed to configure the Address Book is inconsistent

SC870-10: Machine Configuration: A directory for storing the Address Book cannot be created in the SD/USB Flash ROM

SC870-11: Startup: The number of Address Book entries is inconsistent

SC870-20: File I/O: Failed to initialize file

SC870-21: File I/O: Failed to generate file

SC870-22: File I/O: Failed to open file

SC870-23: File I/O: Failed to write file

SC870-24: File I/O: Failed to read file

SC870-25: File I/O: Failed to check file size

SC870-26: File I/O: Failed to delete data

SC870-27: File I/O: Failed to initialize file

SC870-30: Search: Failed to obtain data from cache when searching for Senders/Destinations in the machine's Address Book

SC870-31: Search: Failed to obtain data from cache when searching for the LDAP server

SC870-32: Search: Failed to obtain data from cache when searching the WS-Scanner Address Book

SC870-41: Cache: Failed to obtain data from cache

SC870-50: Startup: Address Book encryption error

SC870-51: Data Encryption: Failed to create directory for converting plain text and encrypted text

SC870-52: Data Encryption: Failed to convert from plain text to encrypted text

- SC870-53: Data Encryption: Failed to convert from encrypted text to plain text
- SC870-54: Data Encryption: Data inconsistency detected when reading the encrypted Address Book
- SC870-55: Data Encryption: Failed to delete file when changing encryption settings
- SC870-56: Data Encryption: When changing encryption settings, failed to delete file containing the encryption key
- SC870-57: Data Encryption: Failed to move file when changing encryption settings
- SC870-58: Data Encryption: Failed to delete directory when changing encryption settings
- SC870-59: Data Encryption: Insufficient resource when changing encryption settings
- SC870-60: Settings: Unable to obtain the on/off setting for Administrator Authentication

### Type

B

### Symptoms

This SC is displayed when an error related to the Address Book is detected at startup or during operation.

### Possible Causes

- There is a bug in the software.
- There is an inconsistency in the Address Book source location (machine/delivery server/LDAP server).
- There is an inconsistency in the Address Book encryption setting or encryption key (NVRAM or HDD was replaced individually without formatting the Address Book).
- The device storing the Address Book (SD or HDD) was temporarily removed, or the hardware configuration does not match the application configuration.
- The Address Book data is corrupted.

### Troubleshooting Procedures

Install the Address Book storage device properly. Turn OFF then ON the main power. If the SC recurs, perform the following steps.

1. **After installing the HDD or SD/USB Flash ROM, execute SP5-846-046.**
2. **Wait more than 3 secs, and then execute SP5-832-006.**
3. **Turn OFF then ON the main power.**

#### Note

- After SC870 is resolved, if there is backup data in the SD card or Web Image Monitor, restore the Address Book data. (To restore from the SD card, enter the same encryption password as the one entered when backing up the data.)

### 5.9.39 SC871-01

**Error Name**

FCU Error

**Type**

D

**Symptoms**

The FCS detects an FCU error.

**Possible Causes**

- There is a time-out error.
- The parameter is invalid.

**Troubleshooting Procedures**

- Turn OFF then ON the main power.
- If a newer version of the firmware is available, update the firmware.

### 5.9.40 SC872-00

**Error Name**

HDD Mail Reception Error

**Type**

B

**Symptoms**

A HDD error was detected when the main power is turned ON.

**Possible Causes**

- The HDD is defective.
- The main power was turned OFF when the machine was accessing the HDD.

**Troubleshooting Procedures**

- Format the HDD (SP5-832-007).
- Replace the HDD.

When the above steps are taken, the following information will be initialized.

- Partly received partial mail messages
- POP3 messages that are received and already read. (All messages on the mail server are handled as new messages.)

## 5.9.41 SC873-00

### Error Name

HDD Mail Reception Error

### Type

B

### Symptoms

A HDD error was detected when the main power is turned ON.

### Possible Causes

- The HDD is defective.
- The main power was turned OFF when the machine was accessing the HDD.

### Troubleshooting Procedures

- Format the HDD (SP5-832-007).
- Replace the HDD.

When the above steps are taken, the following information will be initialized.

- Mail text
- Default sender name and password(SMB/FTP/NCP)
- Administrator mail address
- Scan to email history

## 5.9.42 SC874-XX

### Error Name

- SC874-05: Delete All Error (Delete Data Area): Read Error
- SC874-06: Delete All Error (Delete Data Area): Write Error
- SC874-09: Delete All Error (Delete Data Area): No response from HDD
- SC874-10: Delete All Error (Delete Data Area): Error in Kernel
- SC874-12: Delete All Error (Delete Data Area): No Designated Partition
- SC874-13: Delete All Error (Delete Data Area): No Device File
- SC874-14: Delete All Error (Delete Data Area): Start Option Error
- SC874-15: Delete All Error (Delete Data Area): No Designated Sector Number
- SC874-16: Delete All Error (Delete Data Area): hdderase Execution Failure
- SC874-41: Delete All Error (Delete Data Area): Other Fatal Errors
- SC874-42: Delete All Error (Delete Data Area): End by Cancellation
- SC874-61 to SC874-65: Delete All Error (Delete Data Area): Library Error
- SC874-66: Delete All Error (Delete Data Area): Unavailable
- SC874-67: Delete All Error (Delete Data Area): Erasing Not Finished
- SC874-68: Delete All Error (Delete Data Area): HDD Format Failure (Normal Operation)
- SC874-69: Delete All Error (Delete Data Area): HDD Format Failure (Abnormal Operation)
- SC874-70: Delete All Error (Delete Data Area): Unauthorized Library
- SC874-99: Delete All Error (Delete Data Area): Other Errors

### Type

D

### Symptoms

- An error occurred when deleting data in the HDD or NVRAM.
- Erasing All Memory (deleting all data in the HDD/NVRAM) was executed but the Erase All Memory option was not installed.

### Possible Causes

- An error occurred in the program for deleting the HDD.
- An error occurred when deleting data on the NVRAM.
- The Erase All Memory option was not installed.

### Troubleshooting Procedures

- Turn OFF then ON the main power, and then execute Erase All Memory again from the UP. (However, if there is a defective sector or other problem with the HDD, the error will recur.)
- Reinstall the Erase All Memory option.

### 5.9.43 SC875-01, -02

**Error Name**

SC875-01: Delete All Error (Delete HDD): hddchack -i Error

SC875-02: Delete All Error (Delete HDD): Failed to Delete Data

**Type**

D

**Symptoms**

An error was detected before the deletion of HDD data starts (Failed to erase data/ failed to logically format HDD).

**Possible Causes**

- HDD logical formatting failed.
- The modules failed to erase the data.

**Troubleshooting Procedures**

Turn OFF then ON the main power.

## 5.9.44 SC876-00

### Error Name

Log Data Error

### Type

D

### Symptoms

An error was detected in the handling of the log data at power ON or during machine operation.

### Possible Causes

- The log data file is corrupted (for example, power was cut off during machine operation).
- The log encryption key is invalid (SC876-3). (Log encryption is enabled, but the NVRAM is corrupted, or only the NVRAM is replaced, or only the HDD is replaced, or the HDD is formatted.)
- A mismatch with the HDD occurred because only the NVRAM was replaced (SC876-5).
- A mismatch with the NVRAM occurred because only the HDD was replaced (SC876-5).
- There is a bug in the software.

### Troubleshooting Procedures

1. **Remove the HDD and turn ON the main power.**
2. **Initialize the LCS memory (SP5-801-019).**
3. **Turn OFF the main power.**
4. **Install the HDD and turn ON the main power.**
5. **Execute SP5-832-004.**
6. **Turn OFF the main power.**

The SC should be solved at this point. Steps 7 to 9 are for re-configuring the logging/encryption settings.

7. **Turn ON the main power.**
8. **Set SP9-730-002, SP9-730-003, and SP9-730-004 to “1” (On).**
9. **Turn OFF then ON the main power.**

## 5.9.45 SC877-00

### Error Name

HDD Deletion Card Error

### Type

B

### Symptoms

Auto Erase Memory is not executed even though the option is enabled.

### Possible Causes

- The SD card with the Auto Erase Memory option is corrupted.
- The SD card with the Auto Erase Memory option is not installed.

### Troubleshooting Procedures

- If the SD card is damaged, replace with a new SD card and replace the machine's NVRAM.
- If the SD card is not installed, turn the main power OFF and install an SD card with the Auto Erase Memory option.



## 5.9.46 SC878-00, -01, -02, -03

### Error Name

SC878-00: TPM Authentication Error

SC878-01: USB Flash Error

SC878-02: TPM Error

SC878-03: TCSD Error

SC878-20: Random Number Generator Error

### Type

D

### Symptoms

- SC878-00  
At startup, the system's hash in the TPM and the USB's hash do not match. As a result, authentication by TPM failed.
- SC878-01  
There is an error in the file system of the USB flash memory.
- SC878-02  
There is an error in the TPM or TPM driver.
- SC878-03  
An error occurred in the TPM software stack.
- SC878-20  
An error occurred when doing self-check against seed for random number generated.

### Possible Causes

- SC878-00
  - The system module was not updated via the correct update route.
  - The USB flash memory is malfunctioning.
- SC878-01  
The file system of the USB flash memory is corrupted.
- SC878-02, -20  
The TPM is defective.
- SC878-03
  - The TPM software stack cannot start.
  - A file required by the TPM software stack is missing.

### Troubleshooting Procedures

Turn Off then ON the main power. If the SC recurs, replace the controller board.

## 5.9.47 SC881-01

### Error Name

Management Area Error

### Type

D

### Symptoms

An error occurred in the software.

This error may occur even if an IC card option is not installed.

### Possible Causes

- This error is caused by the accumulation of abnormal authentication information in the software. (It is not directly caused by user action.)
- This error occurs at login (for example, when a job is sent to the printer, when a user logged on from the operation panel, or when a user logged on from a Web browser).

### Troubleshooting Procedures

Turn OFF then ON the main power.

## 5.9.48 SC899-00

### Error Name

Software Performance Error (Signal Reception End)

### Type

D

### Symptoms

Unknown

### Possible Causes

This error occurs when a GW program behaves abnormally.

### Troubleshooting Procedures

- In the case of a hardware fault, replace the hardware.
- In the case of a software fault, turn OFF then ON the main power. Then update the firmware.

## 5.10 SC9XX

### 5.10.1 SC900-00

**Error Name**

Electronic Counter Error

**Type**

D

**Symptoms**

The electronic total counter value is not the specified value.

This error is detected when the counter moves forward.

**Possible Causes**

- The NVRAM connection is not correct.
- The NVRAM is defective.
- The NVRAM data is corrupted.
- The data was written in the wrong area due to external factors.
- When PRT received signals at SRM, the requested count is not completed.

**Troubleshooting Procedures**

Replace the NVRAM.

### 5.10.2 SC920-02, -04

**Error Name**

SC920-02: Printer Application Error (WORK memory cannot be acquired)

SC920-04: Printer Application Error (Filter process ended abnormally)

**Type**

B

**Symptoms**

An error was detected in the application, and no further operation is possible.

**Possible Causes**

- There is a bug in the software.
- The hardware configuration is not as planned (for example, insufficient memory).

**Troubleshooting Procedures**

- Turn OFF then ON the main power.
- Increase the memory storage capacity.

### 5.10.3 SC921-00

**Error Name**

Printer Application Error (Resident Font Not Found)

**Type**

B

**Symptoms**

The resident fonts cannot be found at printer startup.

**Possible Causes**

The resident font file is missing.

**Troubleshooting Procedures**

Turn OFF then ON the main power.

### 5.10.4 SC925-00, -01

**Error Name**

Net File Function Error

**Type**

B

**Symptoms**

The Net File file management area in the HDD cannot be used.

Or the management file is corrupted and no further operation is possible.

**Possible Causes**

- The HDD is defective.
- Power was cut when writing onto the HDD.
- There is a bug in the software.

**Troubleshooting Procedures**

If SC860 to SC865 also happened at the same time, there is a problem with the HDD. Follow the troubleshooting procedures for SC860 to SC865.

If SC860 to SC865 is not detected, perform the following steps:

- Turn OFF then ON the main power.
- If the problem is not solved, initialize the Net File partition on the HDD using SP5-832-11. However, because stored faxes will be erased, permission must be obtained from the customer.
  1. From the file delivery settings screen on the UP, print all received faxes before deleting them.
  2. From the Manage: Delete All Documents Waiting to be Sent screen on the UP, delete all the captured documents.
  3. Execute SP5-832-011.
  4. Turn OFF then ON the main power.

If the problem is not solved after executing SP5-832-011, initialize the HDD partition using SP5-832-001, and then turn OFF then ON the main power. However, because all data in the HDD, such as documents and Address Book, will be lost, permission must be obtained from the customer. (Stored incoming faxes will not be deleted, but the order in which they are received may be changed.)

If the problem is still not solved, replace the HDD.

### 5.10.5 SC990-00

#### Error Name

Software Performance Error

#### Type

D

#### Symptoms, Possible Causes

Unknown

#### Troubleshooting Procedures

Nil

### 5.10.6 SC991-00

#### Error Name

Software Error (Operation Can Continue)

#### Type

C

#### Symptoms

The software performed in an unexpected way. By taking recovery measures, further operation is possible.

#### Possible Causes

- The parameter is invalid.
- There is insufficient work memory.
- This SC is caused by errors that are not normally detected from the hardware.

#### Troubleshooting Procedures

Nil

### 5.10.7 SC992-00

**Error Name**

Undefined SC

**Type**

D

**Symptoms**

An undefined SC has occurred.

**Possible Causes**

There is a bug in the software.

**Troubleshooting Procedures**

Turn OFF then ON the main power.

### 5.10.8 SC997-00

**Error Name**

Application Function Selection Error

**Type**

D

**Symptoms**

The application did not function normally after pressing the application key on the operation panel.

**Possible Causes**

There is a bug in the software.

**Troubleshooting Procedures**

- Check if the options required by the application (RAM, DIMM, boards) are installed properly.
- Check whether downloaded applications are correctly configured.

## 5.10.9 SC998-00

### Error Name

Application Start Error

### Type

D

### Symptoms

- After power ON, no application program was registered to the system within the specified period of time. (No application started or ended normally.)
- Even though the application started up, it cannot be rendered due to an unknown fault.

### Possible Causes

- There is a bug in the software.
- The options required by the application (RAM, DIMM, board) are not installed.

### Troubleshooting Procedures

- Turn OFF then ON the main power.
- Check the RAM, DIMM, and boards.
- Check the application configurations.
- Replace the controller board.



## 5.11 JAM DETECTION

### 5.11.1 PAPER JAM DISPLAY

SP7-507 [Plotter Jam History] shows the paper jam history.

```
CODE :011
SIZE  :05h
TOTAL:000034
DATE  :Fri Feb 15 11:44:50 2006
```

- **CODE:** Indicates the jam code.
- **SIZE:** Indicates the paper size code in hex.
- **TOTAL:** Indicates the total counter (SP7-502-001).
- **DATE:** indicates the date when the jam occurred.

#### Note

- The 10 latest printer jams are displayed.
- Initial jams are not recorded.

### 5.11.2 JAM CODES AND DISPLAY CODES

When a jam occurs, the location is displayed on the operation panel.

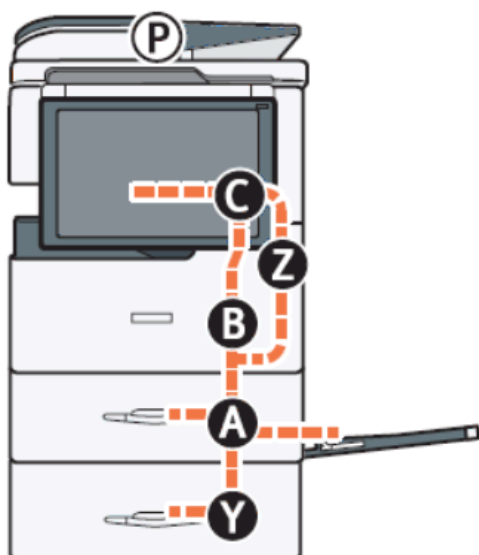

d205z6560

#### Note

- **Jam Code:** Indicates the cause of a jam. Appears in the log data.
- **Position Code:** Indicates the jam location. Appears on the operation panel screen.
- **Cover Open Direction:** Indicates which cover should be open to check. Does not appear on the operation panel screen.

**Jam Code List (Main machine), Cover Open Direction**

Jam Code	Description	Position Code	Cover Open Direction
1	Paper Exit Sensor does not turn OFF.	C	Right cover
	Registration Sensor does not turn OFF.		
3	Paper is not fed from Tray 1	A	Right cover
5	Paper is not fed from Tray 2	Y	Right Door (Optional Paper Feed Tray)
8	Bypass Registration Sensor does not detect paper.	A	Right cover
9	Duplex Registration Sensor does not detect paper.	Z	Right cover
17	Registration Sensor does not detect paper.	A	Right cover
20	Paper Exit Sensor does not detect paper.	C	Right cover
53	Paper is held up in Paper Feed Sensor.	A,Y	Right cover Right Door (Optional Paper Feed Tray)
57	Paper is held up in Registration Sensor.	B	Right cover
60	Paper is held up in Paper Exit Sensor.	C	Right Door (Optional Paper Feed Tray)

**Jam Code List (Duplex), Cover Open Direction**

Jam Code	Description	Position Code	Cover Open Direction
1	Duplex Entrance Sensor does not turn OFF	Z	Right Cover
	Paper Feed Sensor does not turn OFF.		
	Duplex Exit Sensor does not turn OFF		
5	Paper is not fed from Tray 2.	Y	Right Door
25	Duplex Exit Sensor does not detect paper.	Z	Right Cover
27	Duplex Entrance Sensor does not detect paper.	Z	Right Cover
53	Paper is held up in the Paper Feed Sensor.	A,Y	Right cover Right Door (Optional Paper Feed Tray)
65	Paper is held up in the Duplex Exit Sensor.	Z	Right Cover
67	Paper is held up in the Duplex Entrance Sensor.	Z	Right Cover

***Jam Code List (ARDF) , Cover Open Direction***

Jam Code	Description	Position Code	Cover Open Direction
1	Initial Jam	P	ARDF Feed Cover
4	ARDF Registration Sensor does not detect the original.	P	ARDF Feed Cover
54	Original is held up in the ARDF Registration Sensor.	P	ARDF Feed Cover
100	ARDF Drive Motor is defective.	P	ARDF Feed Cover

### 5.11.3 SENSOR LAYOUT

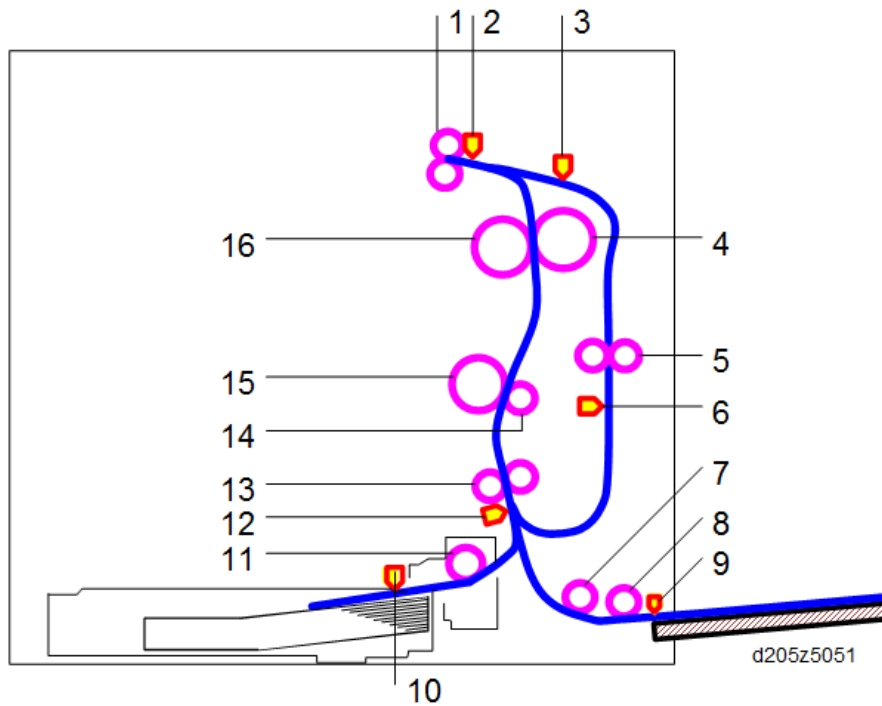

No.	Item	No.	Item
1	Paper Exit Roller	9	Bypass Paper End Sensor
2	Paper Exit Sensor	10	Paper End Sensor
3	Duplex Entrance Sensor	11	Paper Feed Roller
4	Pressure Roller	12	Registration Sensor
5	Duplex Roller	13	Registration Roller
6	Duplex Exit Roller	14	Transfer Roller
7	Bypass Feed Roller	15	Drum
8	Pick-up Roller	16	Hot Roller

## 5.11.4 PAPER SIZE CODES

Paper size codes are as follows.

\* The unit of Main Scan/Sub Scan Length is 0.1 mm.

Size Code	Paper Size Name	Orientation	Main Scan Length	Sub Scan Length
132(84H)	A3	SEF	2970	4200
005(05H)	A4	LEF	2970	2100
133(85H)	A4	SEF	2100	2970
141(8DH)	B4	SEF	2570	3640
006(06H)	A5	LEF	2100	1480
134(86H)	A5	SEF	1480	2100
014(0EH)	B5	LEF	2570	1820
142(8EH)	B5	SEF	1820	2570
135(87H)	A6	SEF	1050	1480
143(8FH)	B6	SEF	1280	1820
160(A0H)	11"x17"(DLT)	SEF	2794	4318
164(A4H)	8 1/2"x14"(LG)	SEF	2159	3556
166(A6H)	8 1/2"x11"(LT)	SEF	2159	2794
038(26H)	8 1/2"x11"(LT)	LEF	2794	2159
172(ACH)	5 1/2"x8 1/2"(HLT)	SEF	1397	2159
175(AFH)	12" x 18"	SEF	3048	4572

## 5.12 OTHER PROBLEMS

### 5.12.1 HOW TO RE-INSTALL THE OCR UNIT

When the OCR unit is installed, its function is stored in the HDD, and its ID information in the SD card is stored in the NVRAM. So the OCR unit must be installed again when you replace the HDD and/or NVRAM.

**If you have the original SD card and when you replaced:**

- Only HDD  
Re-install the unit with the original SD card.
- Only NVRAM  
Re-install with the original SD card if you upload/download of the NVRAM data.  
Order a new SD card and Re-install with the new SD card if you do not upload/download of the NVRAM data.
- Both the HDD and NVRAM at the same time  
Re-install the original SD card.

**If you do not have the original SD card:**

Order a new SD card and Re-install with the new SD card.

 **Note**

- Re-installation procedure is the same as the installation procedure. (page 1-75)

### 5.12.2 DECREASING THE FUSING PRESSURE

As a tentative treatment for fusing curl, decrease the fusing pressure as shown below.

#### **Pressure Mechanism**

Layout of the fusing unit

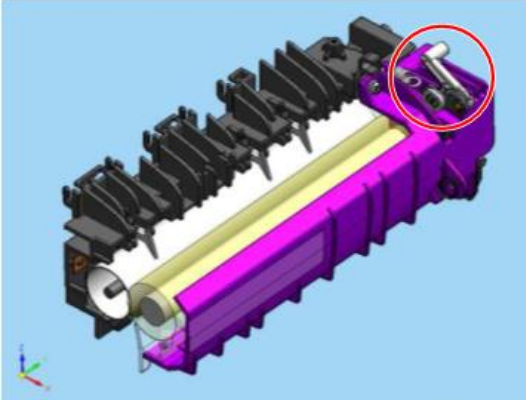

d205k7001

Layout of the pressure block

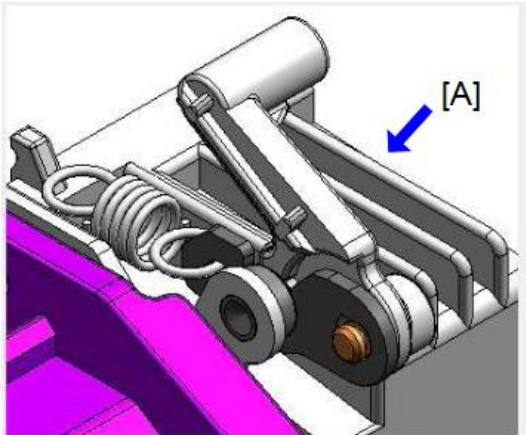

d205k7002

Pressure mechanism (view from [A])

Troubleshooting



## Other Problems

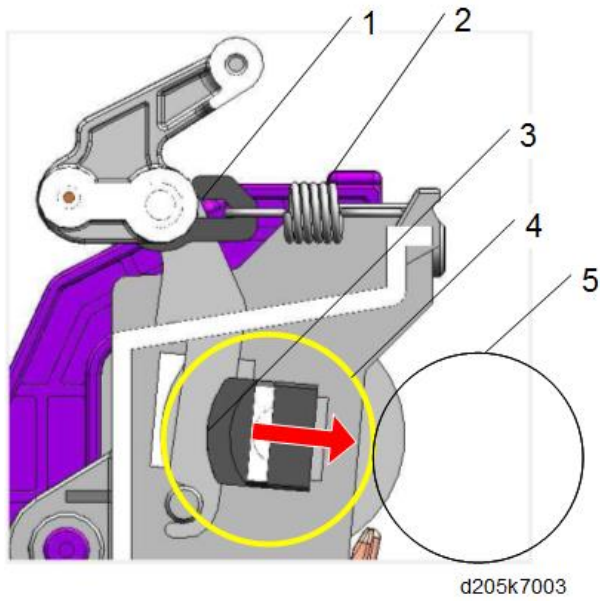

1	Lever
2	Pressure spring
3	The pressure roller is pushed against the hot roller by pressure from the spring latched to the lever.
4	Pressure roller
5	Hot roller

### ***Decreasing the Pressure***

Pressure is decreased by removing the wound bushing attached to the pressure lever.

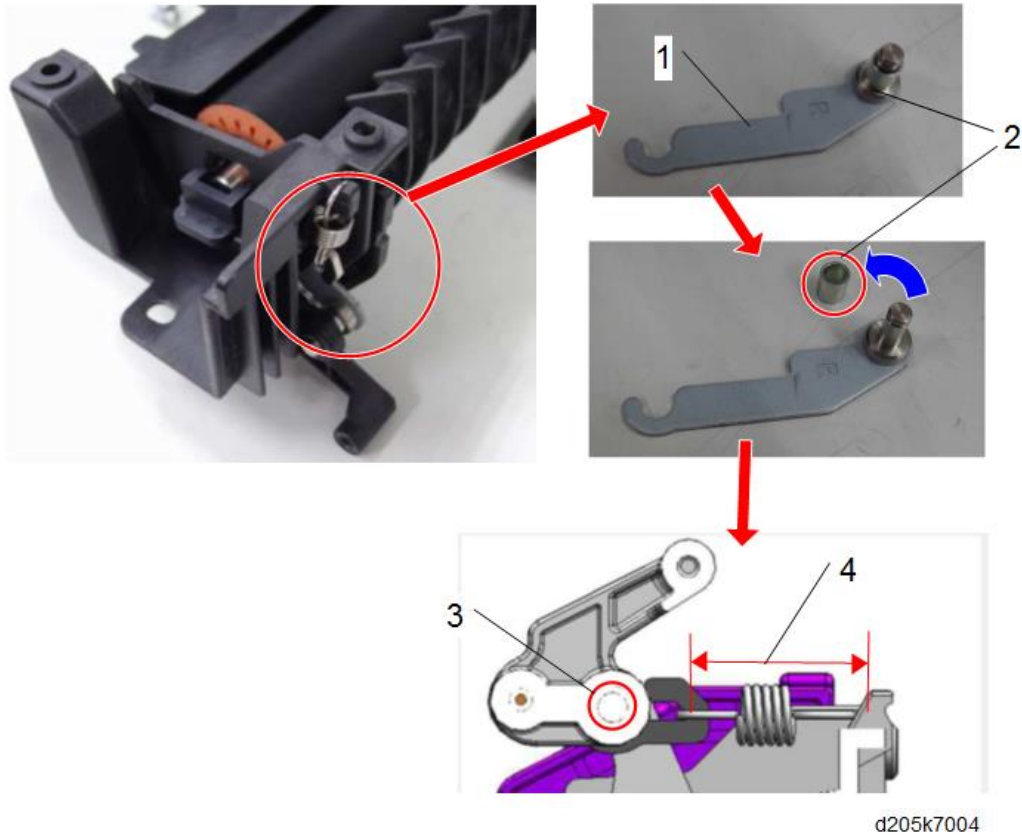

1	Pressure lever
2	Remove the wound bushing (07074060N) and mount it again.
3	Wound bushing
4	Spring length If you remove the bushing, the spring length will be shortened by the thickness of the bushing, which results in decreasing the pressure.

Spring load: 38 N [AA064002 x 2 (F-R)]

After the bushing removed: 34 N (decreased by 10%)

Remove the bushings at both front and rear.

Decreasing the pressure may cause insufficient fusing. Do this considering the usage conditions of the customer.

Removing the bushing repeatedly may cause the Mo part to be reduced. So use this measure tentatively.

## 5.13 FUSE LOCATION

These fuses are all on the PSU board.

Symbol	Connector	C	V	Made by	Part Name	Note
FU1	CN286-4(5VX) CN286-5(5V) CN286-6(24V) CN283-1,3(AC)	15A	250V	HOLLYLAND	65TSRB15AT-JUCR	Not replaceable
FU2	CN286-4(5VX) CN286-5(5V) CN286-6(24V)	8A	250V	LITTLEFUSE	215RB8AR-SBR	Not replaceable
FU4	CN286-5(5V_LPS)	5A	250V	CONQUER SKYGATE	MSTRB5AR-T SCTRB5AR-ALT	Not replaceable
FU5	CN286-6(24V)	8A	250V	LITTLEFUSE	215RB8AR-SBR	Not replaceable

# DETAILED DESCRIPTIONS

REVISION HISTORY		
Page	Date	Added/Updated/New
		None



## 6. DETAILED DESCRIPTIONS

### 6.1 PRODUCT OVERVIEW

#### 6.1.1 COMPONENT LAYOUT

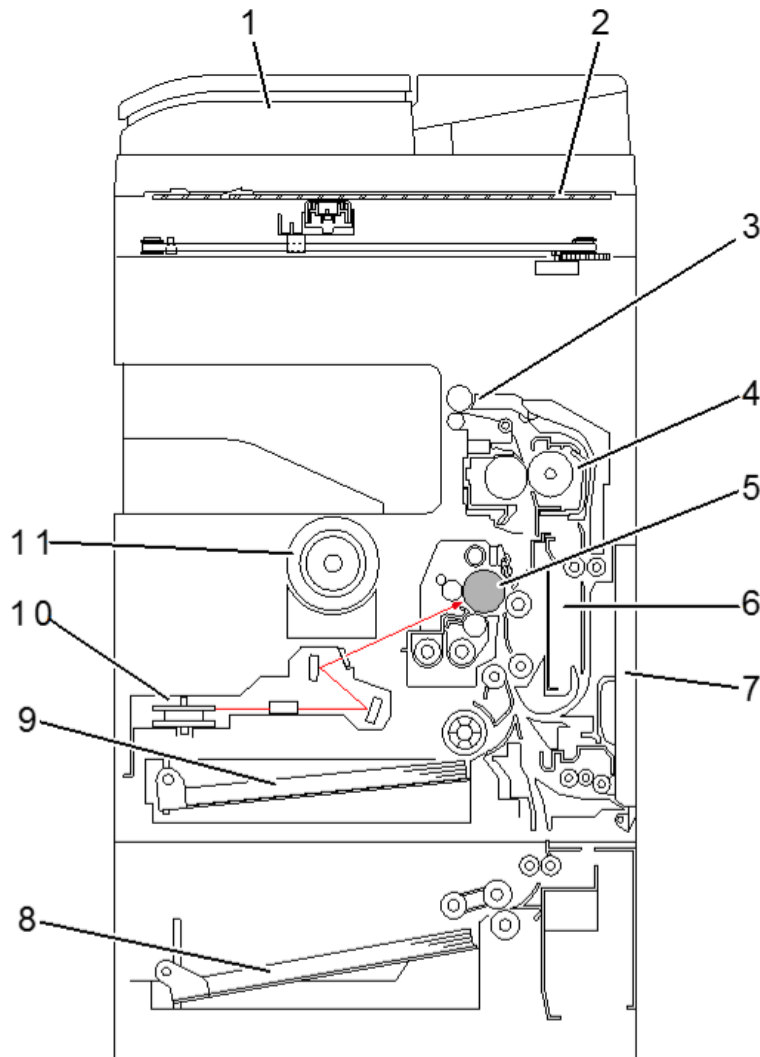

d205c9001

Detailed  
Descriptions

No.	Items	No.	Items
1	ARDF (Auto Reverse Document Feeder)	7	Bypass Feed Unit
2	Scanner Unit	8	Optional Paper Feed Unit
3	Paper Exit Unit	9	Main Paper Feed Unit
4	Fusing Unit	10	Laser Unit
5	PCDU (Photo Conductor and Development Unit)	11	Toner Supply Unit
6	Duplex Unit		

### 6.1.2 PAPER PATH

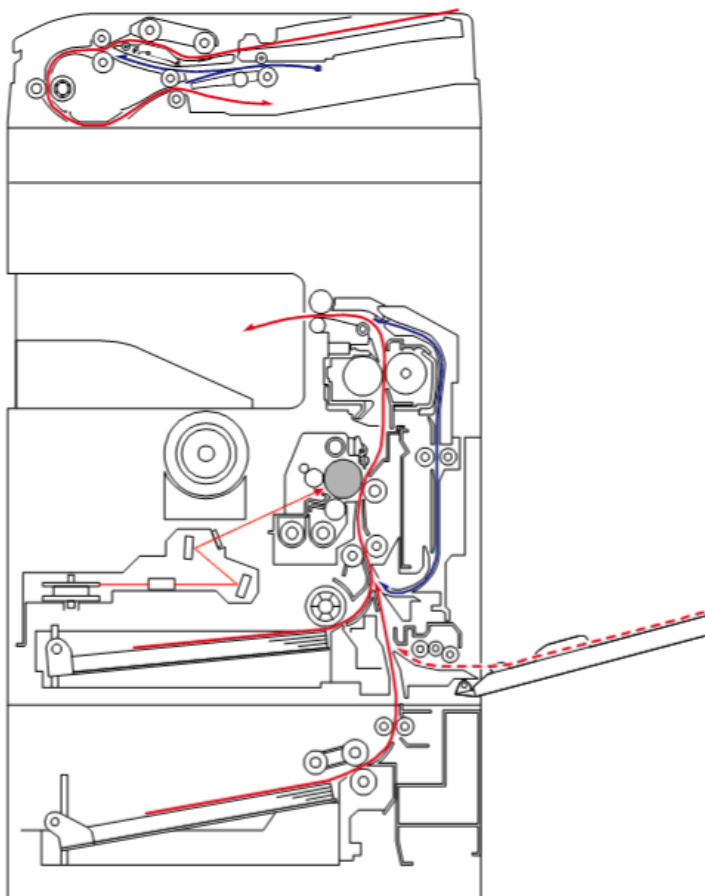

d205c9003

### 6.1.3 DRIVE LAYOUT

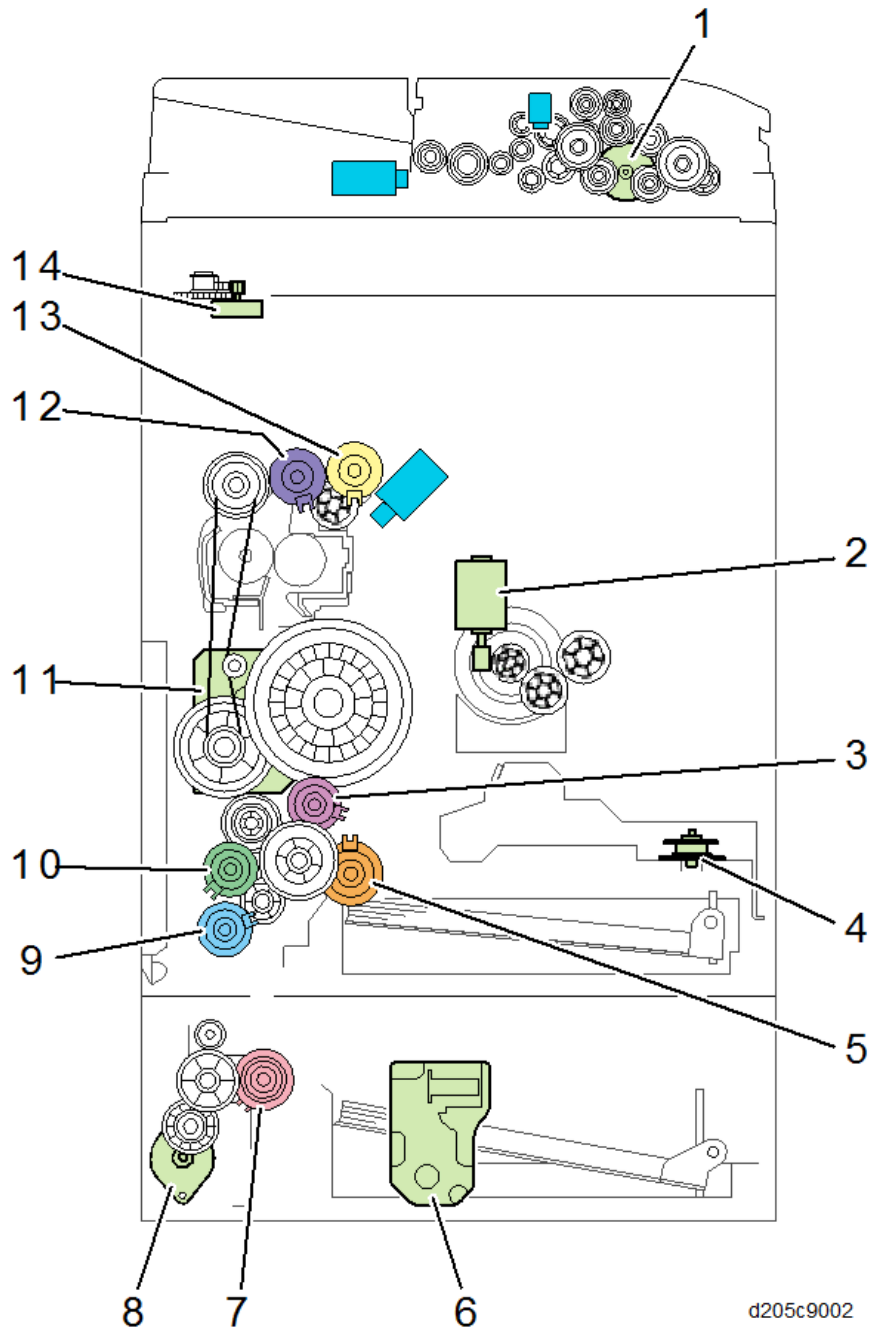

Detailed  
Descriptions



## Product Overview

No.	Items	No.	Items
1	ARDF Drive Motor	8	Paper Feed Motor (Optional Tray)
2	Toner Supply Motor	9	Bypass Clutch
3	Registration Clutch	10	Duplex Reverse Clutch
4	Polygon Motor	11	Main Motor
5	Paper Feed Clutch (Main Tray)	12	Reverse Exit Clutch
6	Tray Lift Motor (Optional Tray)	13	Paper Exit Clutch
7	Paper Feed Clutch (Optional Tray)	14	Scanner Motor

## 6.1.4 PARTS LAYOUT

### Scanner Unit

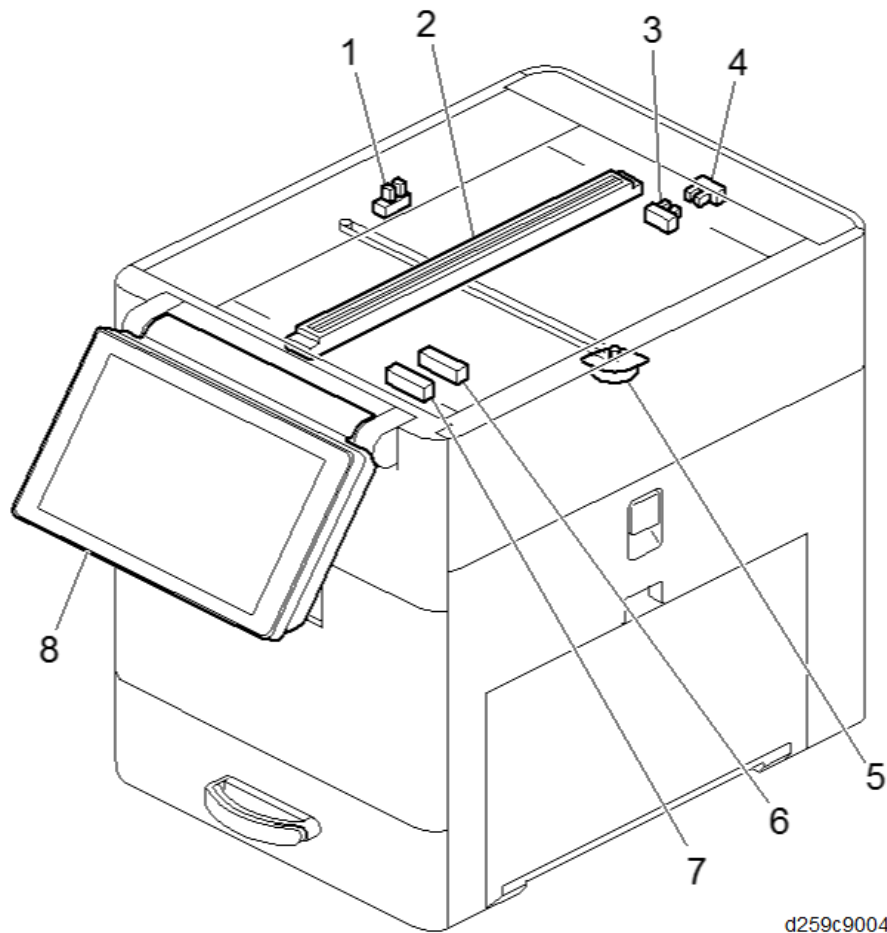

d259c9004

No.	Items	No.	Items
1	Scanner HP Sensor	5	Scanner Motor
2	CIS	6	APS Sensor (other than NA)
3	ARDF Position Sensor	7	APS Sensor
4	Platen Cover Sensor	8	Operation Panel

### Duplex/Bypass Unit

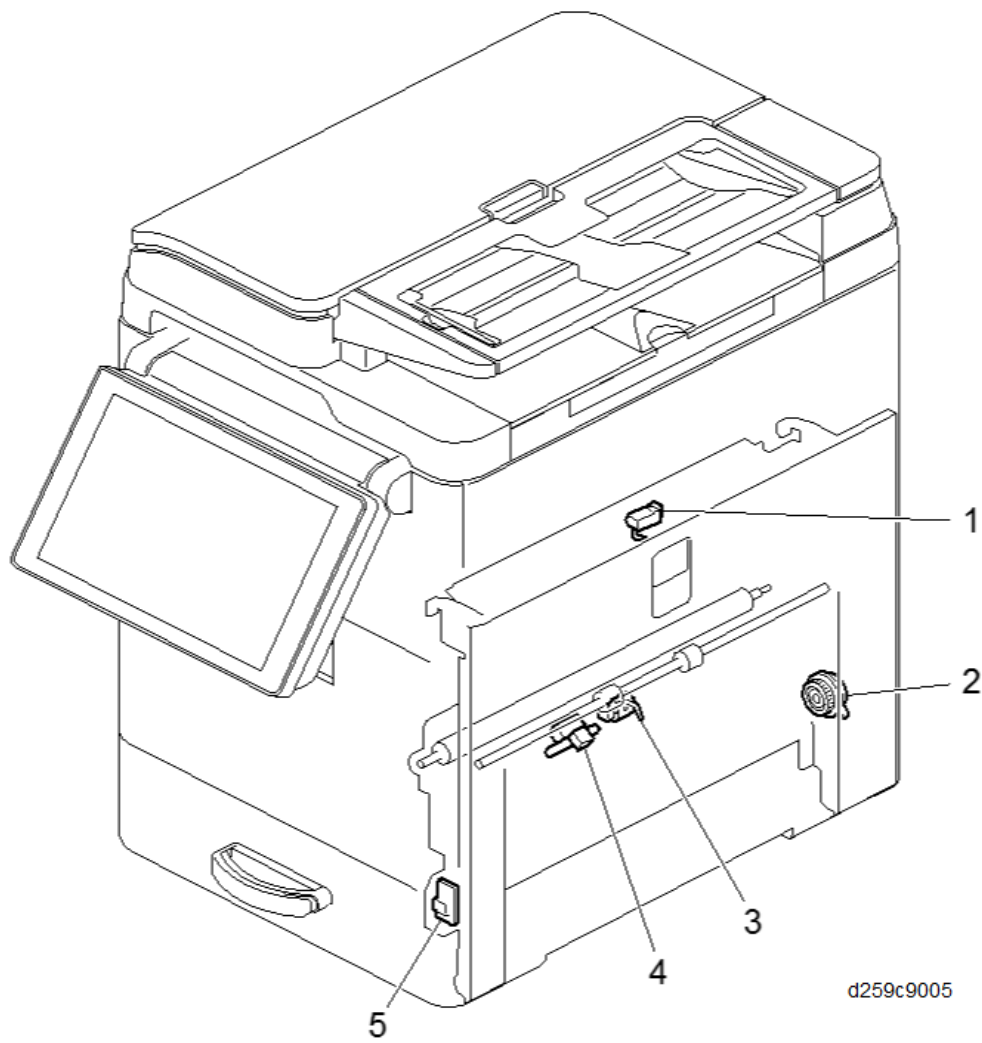

No.	Items
1	Duplex Entrance Sensor
2	Duplex Clutch
3	Duplex Exit Sensor
4	ID Sensor
5	Temperature/Humidity Sensor

**Laser Unit, PCDU**

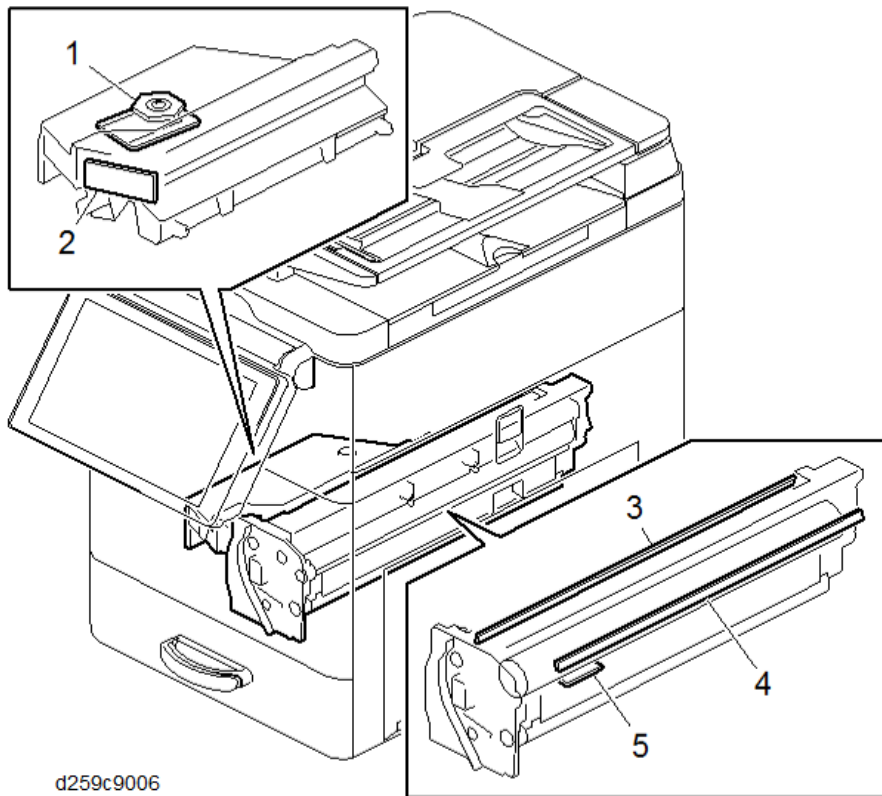

d259c9006

No.	Items
1	Polygon Motor
2	LDB
3	Quenching Lamp
4	Pre-cleaning Lamp (PCL)
5	TD Sensor

Detailed Descriptions

### ***Toner Supply Unit***

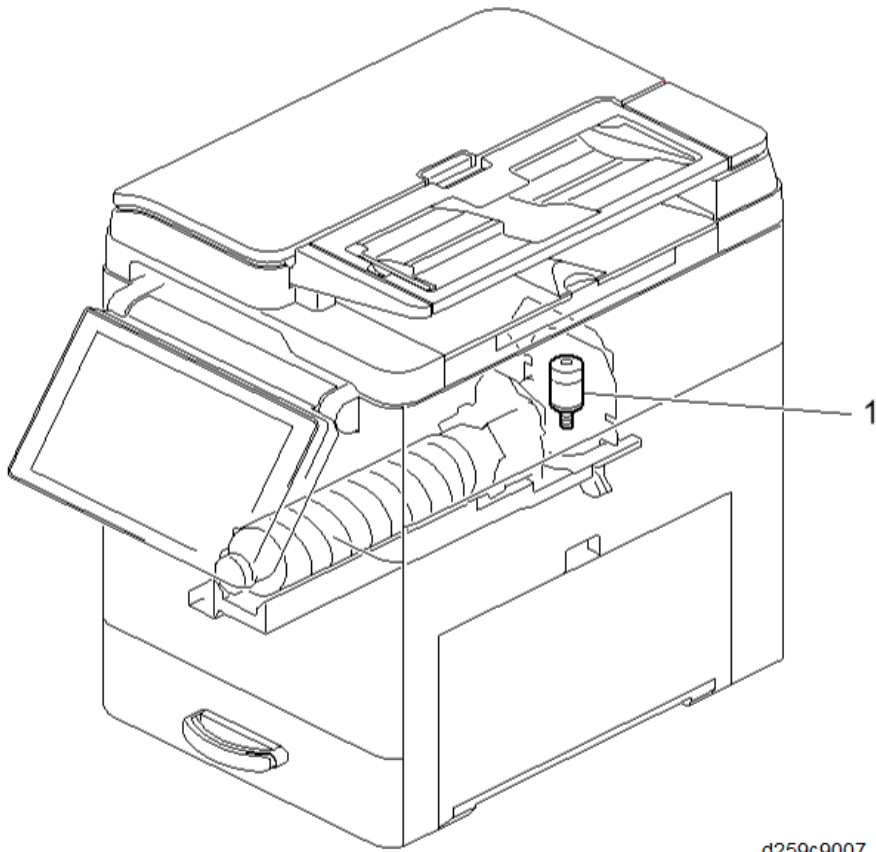

d259c9007

No.	Items
1	Toner Supply Motor

**Fusing Unit, Paper Exit Section**

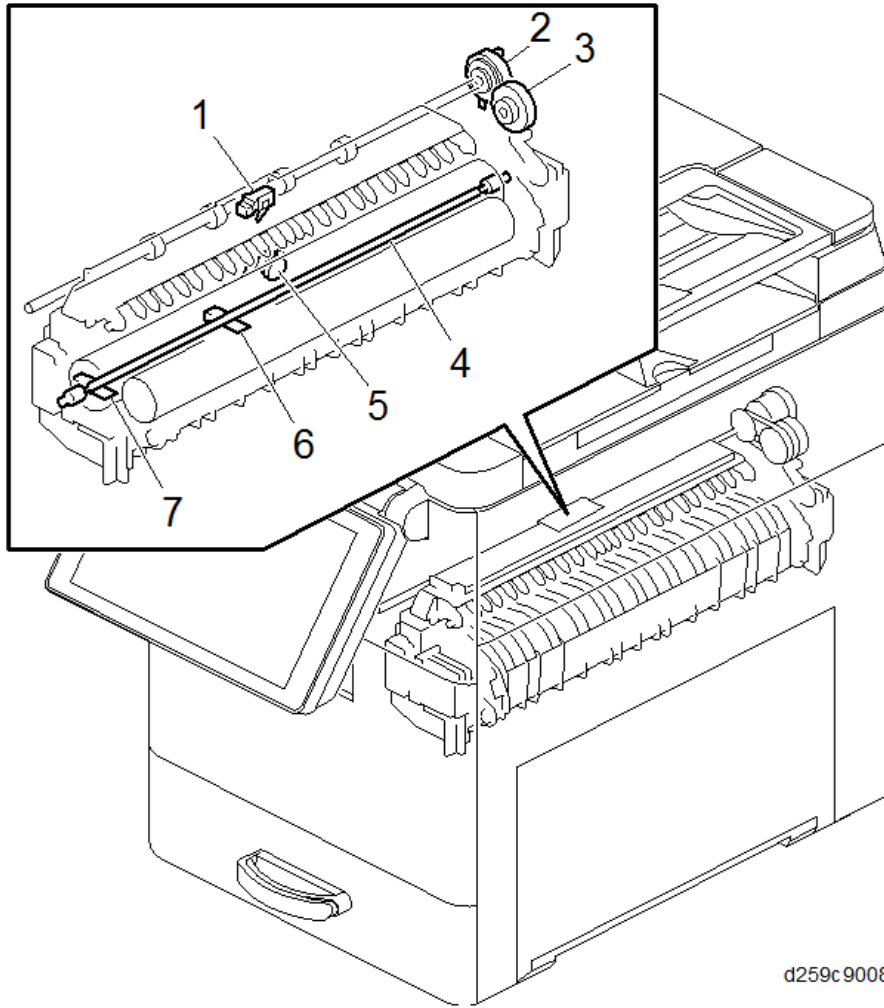

d259c.9008

No.	Items	No.	Items
1	Paper Exit Sensor	5	Thermostat
2	Reverse Exit Clutch	6	Thermistor (Center)
3	Reverse Clutch	7	Thermistor (End)
4	Fusing Lamp	-	

Detailed Descriptions

**Paper Feed Unit**

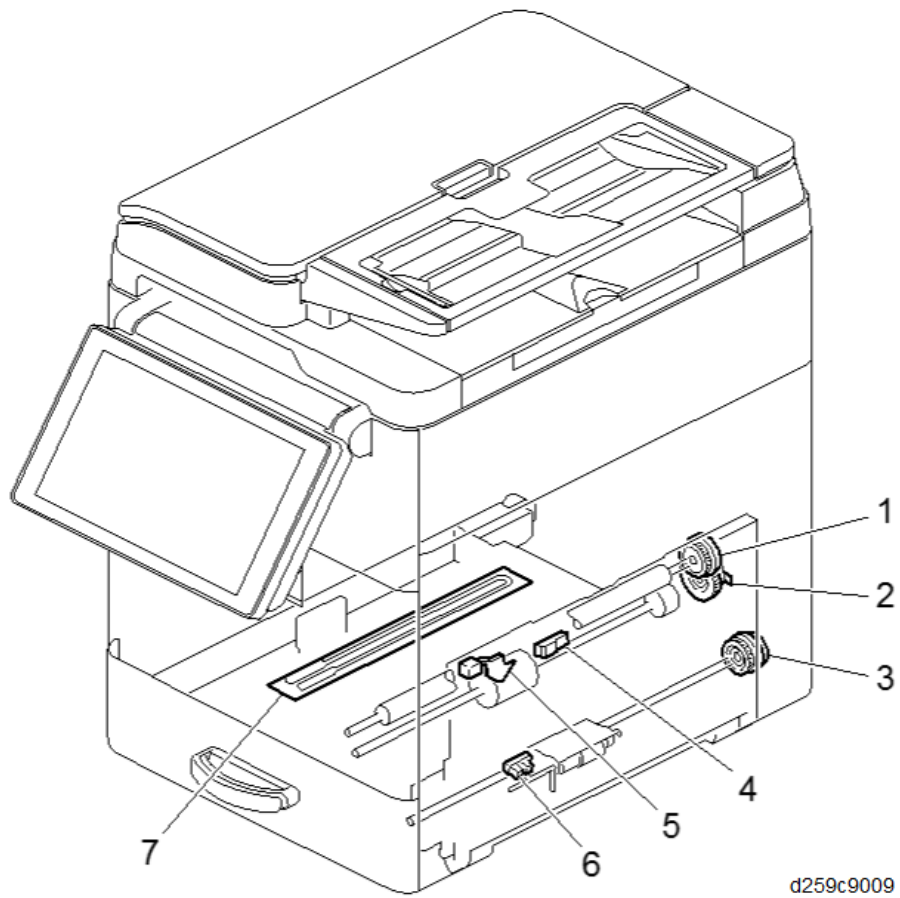

d259c9009

No.	Items	No.	Items
1	Registration Clutch	5	Paper End Sensor
2	Paper Feed Clutch	6	Bypass Paper End Sensor
3	Bypass Clutch	7	Main Tray Dehumidification Heater
4	Registration Sensor	-	

**Drive Unit**

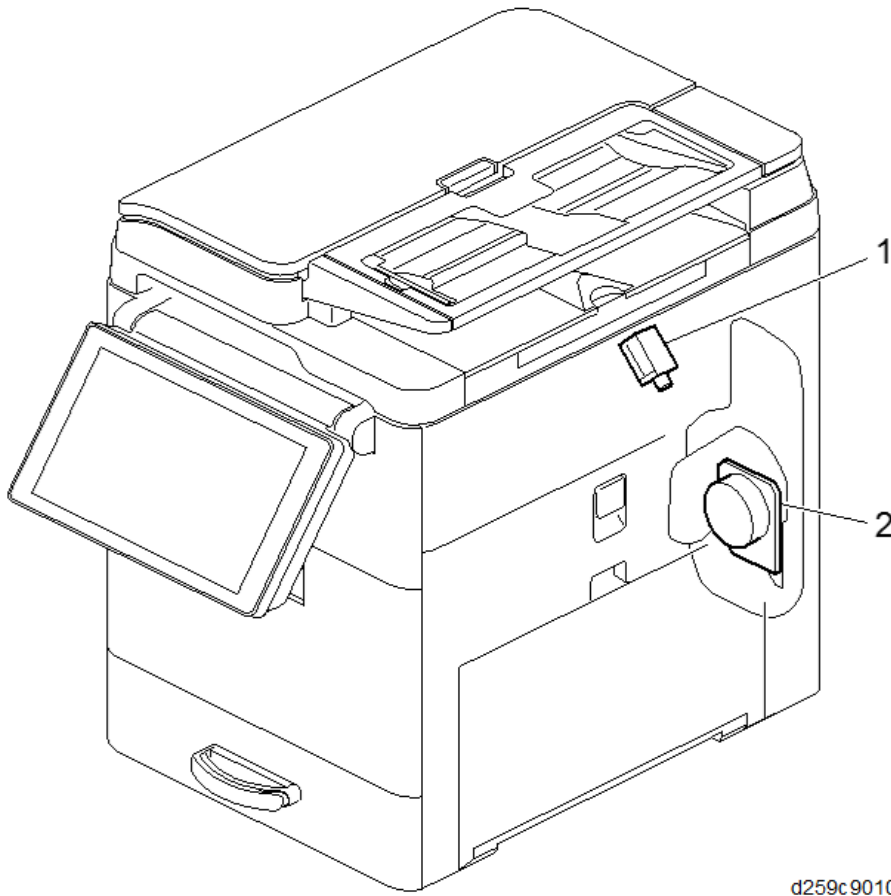

d259c9010

No.	Items
1	Fusing Solenoid
2	Main Motor

Detailed Descriptions



**Electrical Components 1**

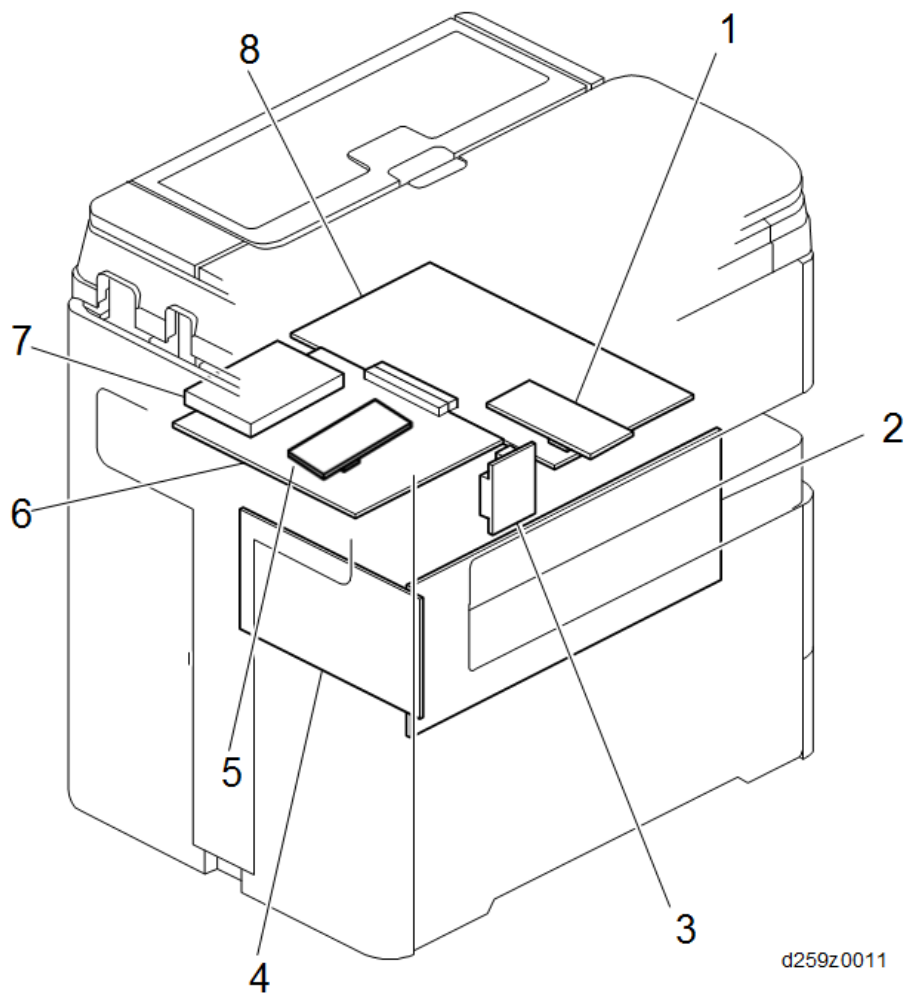

d259z0011

No.	Items	No.	Items
1	Copy Data Security Unit	5	FCU (SPF models only)
2	PSU	6	Controller Board
3	Optional Counter Interface Unit	7	HDD
4	HVPS	8	BiCU

**Electrical Components 2**

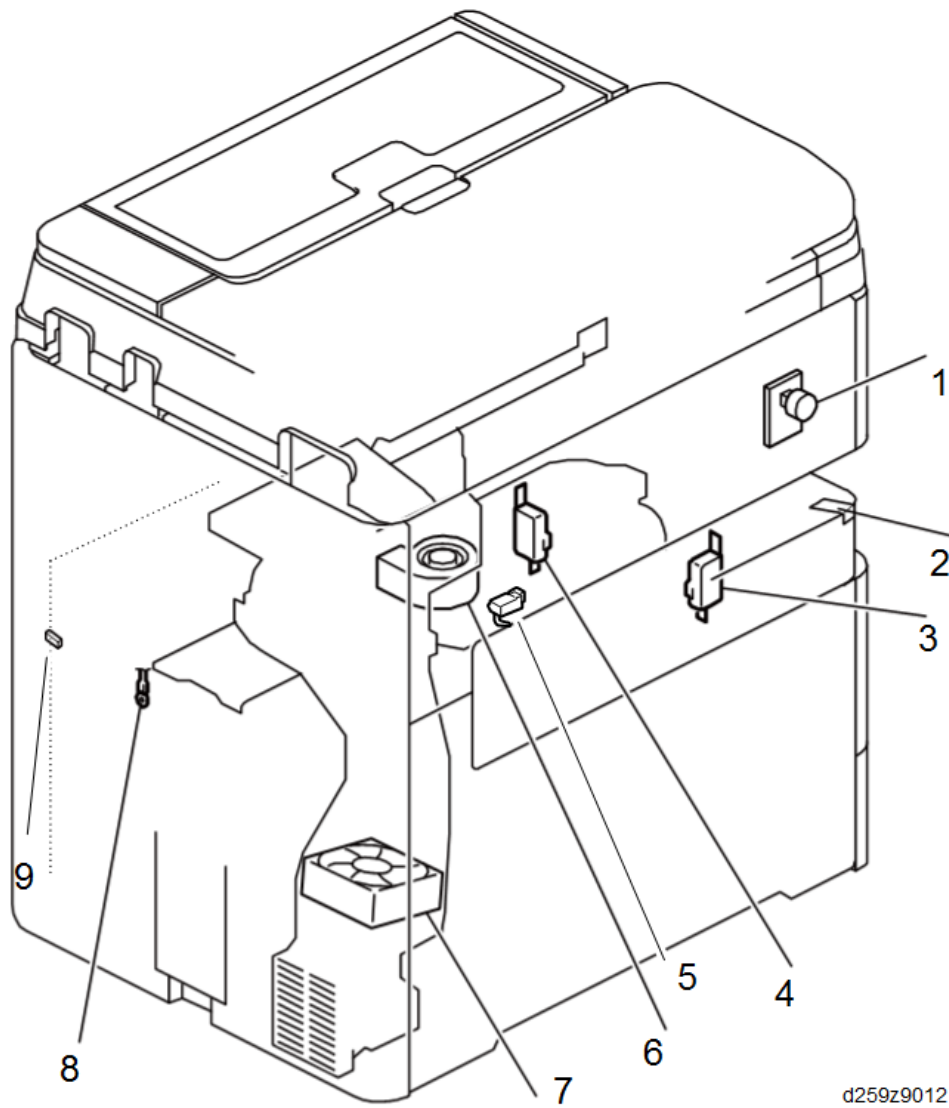

Detailed Descriptions

No.	Items	No.	Items
1	Main Power Switch	6	Intake Fan
2	Paper Exit Indicator	7	Exhaust Fan
3	Front Cover Switch	8	Internal Temperature Sensor
4	Right Cover Interlock Switch	9	Right Cover Push Switch
5	Exit Tray Paper Sensor		

## 6.2 SCANNER UNIT

### 6.2.1 OVERVIEW

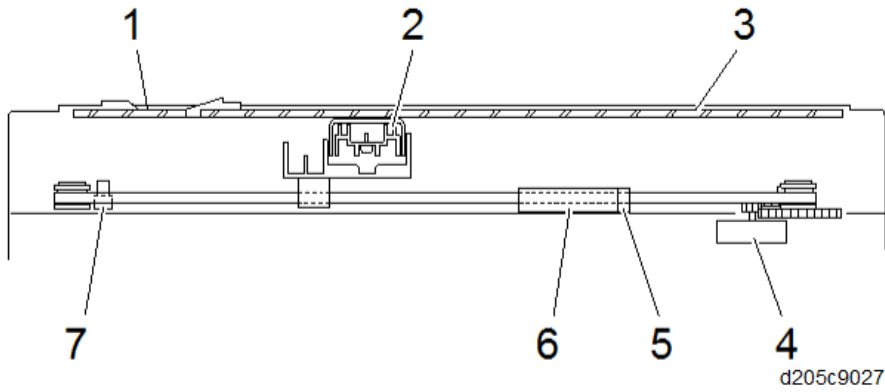

No.	Items	No.	Items
1	ARDF exposure glass	5	APS sensor
2	CIS and carriage unit	6	APS sensor (EU Only)
3	Exposure glass	7	Scanner HP sensor
4	Scanner motor		

## 6.2.2 MECHANISM

This model uses a six-channel full color CIS (Contact Image Sensor) unit. The BiCU provides the power to the CIS unit through an FFC.

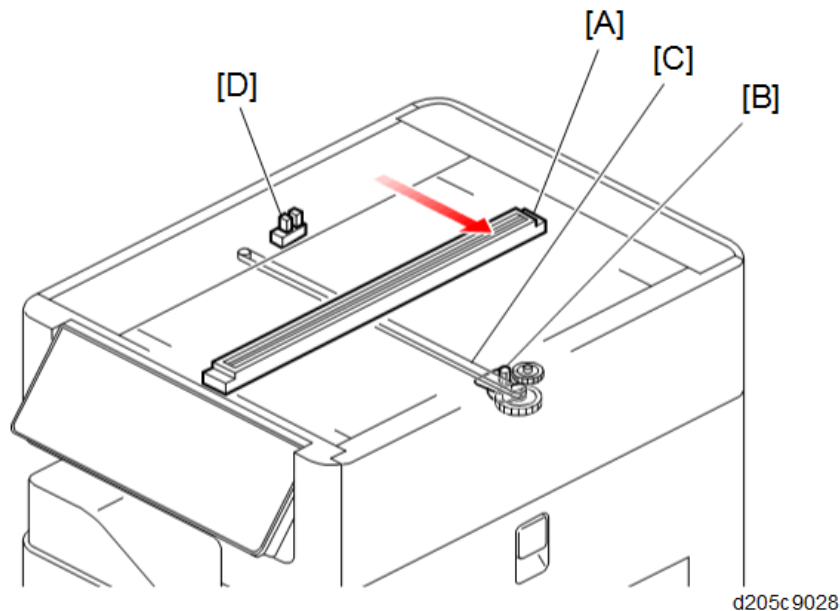

The scanner motor [B] moves the scanner carriage [A] in the main scan direction through the timing belt [C].

While the carriage is moving along the guide rail, the CIS unit on the carriage scans the originals.

The scanner HP sensor [D] controls the position of the carriage.

There are two scan modes for this model:

### **Platen Scan Mode:**

To scan an original on the exposure glass, the scanner motor moves the carriage from the home position (left) to the right.

### **ARDF Scan Mode:**

The original set on the ARDF is transported over the ARDF exposure glass. The carriage stays at its home position right under the ARDF exposure glass, and the CIS unit scans the originals passing the ARDF exposure glass.

## ***Original Width Detection***

### **Mechanism**

This model uses one or two APS sensor(s) for detecting the width of an original. The number of APS sensors depends on destinations:

For EU: Two APS sensors

For NA: One APS sensor

The platen cover sensor is used to detect the timing of original size detection. When the platen cover sensor is OFF, the scanner carriage moves to the right. When the platen cover sensor is ON,

## Scanner Unit

the scanner carriage moves back to its home position to scan the original size.

The ARDF position sensor is used to detect if the ARDF opens or closes.

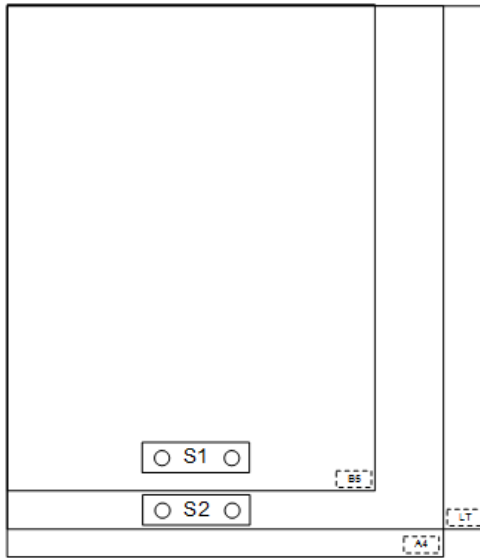

d205z7003

Paper Size			APS detects?	
Size	LEF/SEF	mm	S1	S2
A4	LEF	297x210	Yes	Yes
B5	LEF	257x182	Yes	-
A5	SEF	148x210	-	-
A5	LEF	210x148	-	-
B6	SEF	128x182	-	-
B6	LEF	182x128	-	-

### 6.2.3 RELATED SPS

- **SP4-301-001 [Operation Check]-[APS Sensor]:**  
Allows the customer engineers to check the sensor status. This SP shows bits as “(7)00000000(0)”.  
0: Paper not detected, 1: Paper detected
- **SP4-305-001 [APS Detection Setting]:**  
Allows the customer engineers to scan A4/Letter mixed originals or the paper sizes used in China such as 8K/16K.
- **SP4-303-001 [Min Size for APS]:**  
Allows the customer engineers to set the machine’s behavior when the APS sensor detects an original such as A5/HLT or smaller.

## 6.3 ARDF

### 6.3.1 OVERVIEW

#### Layout

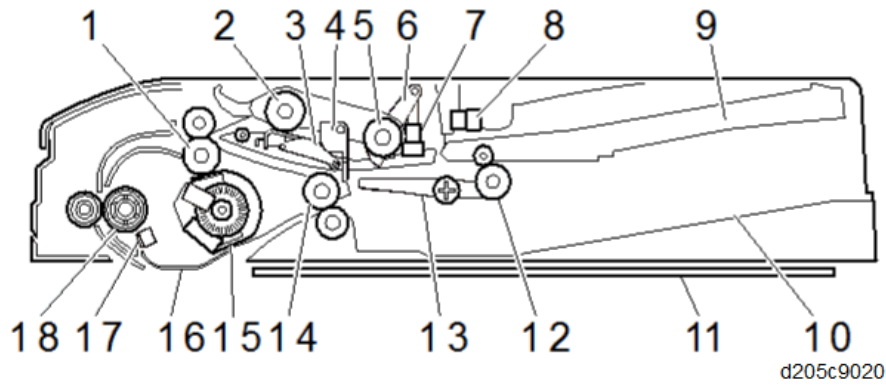

	Item		Item
1	Transport roller (pullout)	10	Original exit tray
2	Feed roller	11	Platen cover
3	Friction pad	12	Reverse roller
4	Original stopper	13	Junction gate
5	Pickup roller	14	Paper exit roller
6	Original set actuator	15	ARDF drive motor
7	Original set sensor	16	White plate guide
8	Feed cover sensor	17	Registration sensor
9	Original feed tray	18	Transport roller (scan)

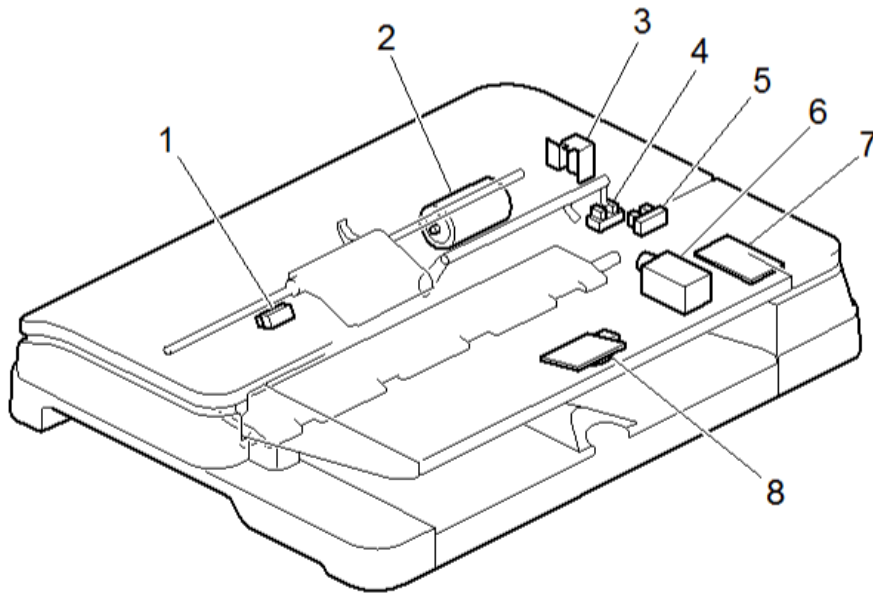

d205c9021

	Item		Item
1	Registration sensor	5	Feed cover sensor
2	ARDF drive motor	6	ARDF reverse solenoid
3	ARDF feed solenoid	7	Relay board
4	Original set sensor	8	Original width sensor



## 6.3.2 DETAILED DESCRIPTION

### **ARDF Drives**

The ARDF drive motor [A] drives the rollers in the ARDF via the gears.

The feed solenoid [B] controls the original pick-up. The reverse solenoid [C] switches the junction gate and rotates the reverse roller during duplex scanning.

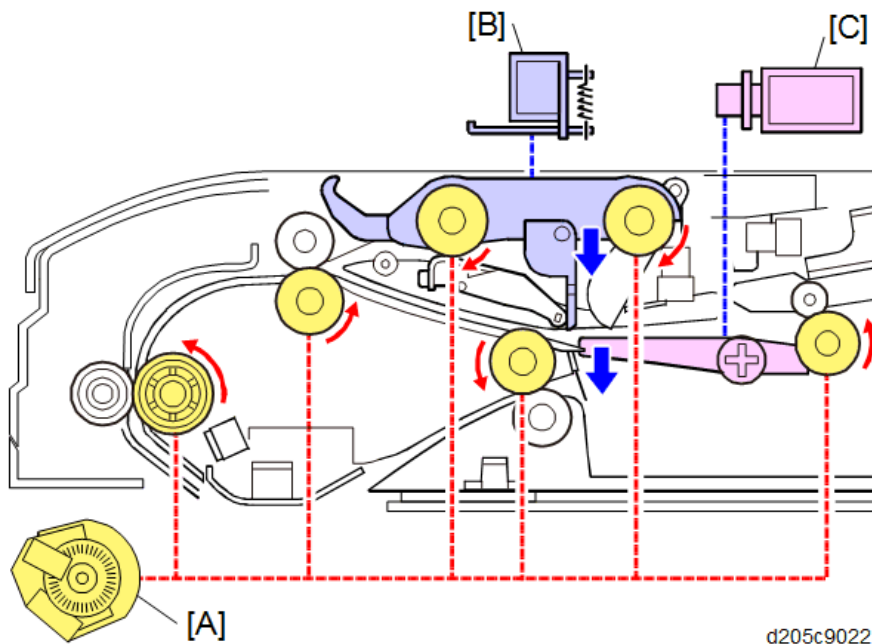

### **Original Set Detection**

When an original is set [D], the original pushes against the original set actuator [B]. The original set sensor [C] is uncovered and detects the original.

The stopper [A] prevents the original from being pushed too far into the feeder.

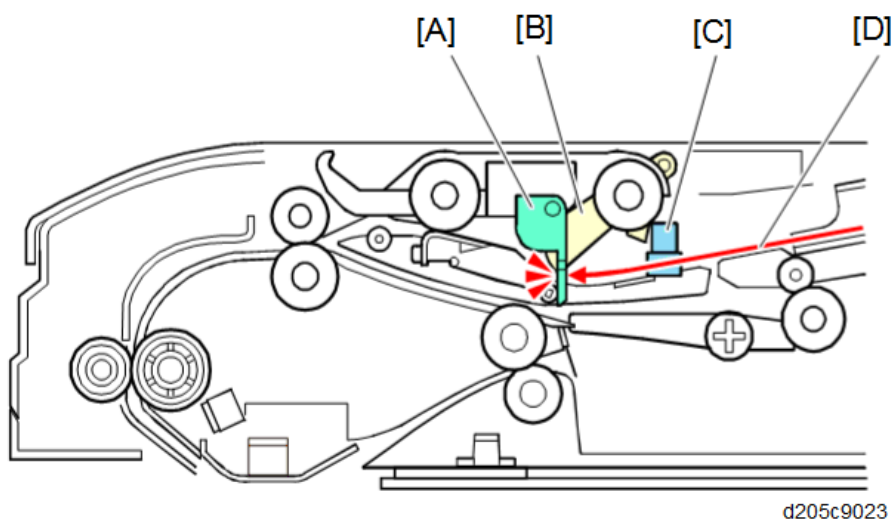

### Original Transport (Single-sided Scanning)

When the Start key is pressed to begin scanning, the feed solenoid turns ON and lowers the pickup roller. The original passes through the feed roller [B] and is then transported to the 1st transport roller [C].

When a number of originals are set at the same time, the friction pad [D] prevents double feeding by feeding only the sheet on top to the 1st transport roller.

During original transport, the stopper [E] is released to ensure smooth transportation.

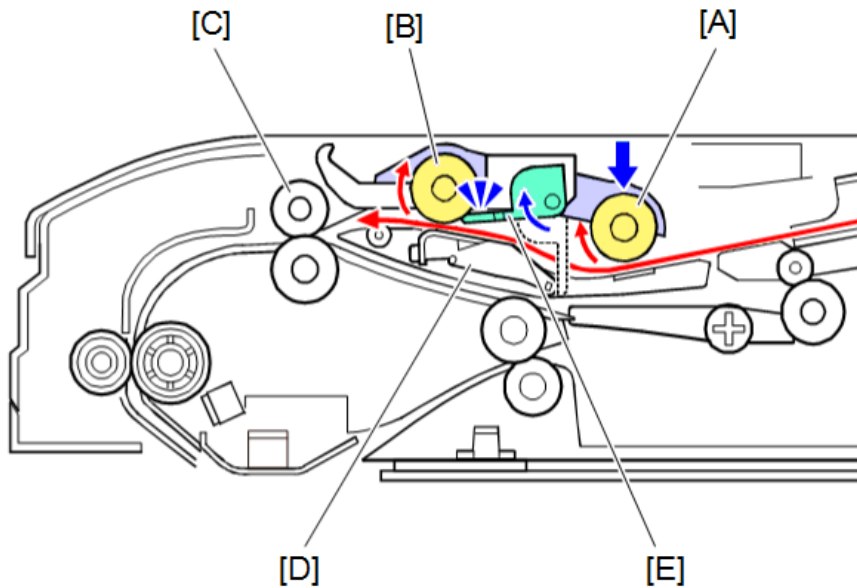

d205c9024

The original is fed through the 1st transport roller [A] and 2nd transport roller [B]. It is scanned on the exposure glass under the white plate guide [C], and comes out through the original exit roller [D].

The original transport sensor [E] detects jams in the ARDF.

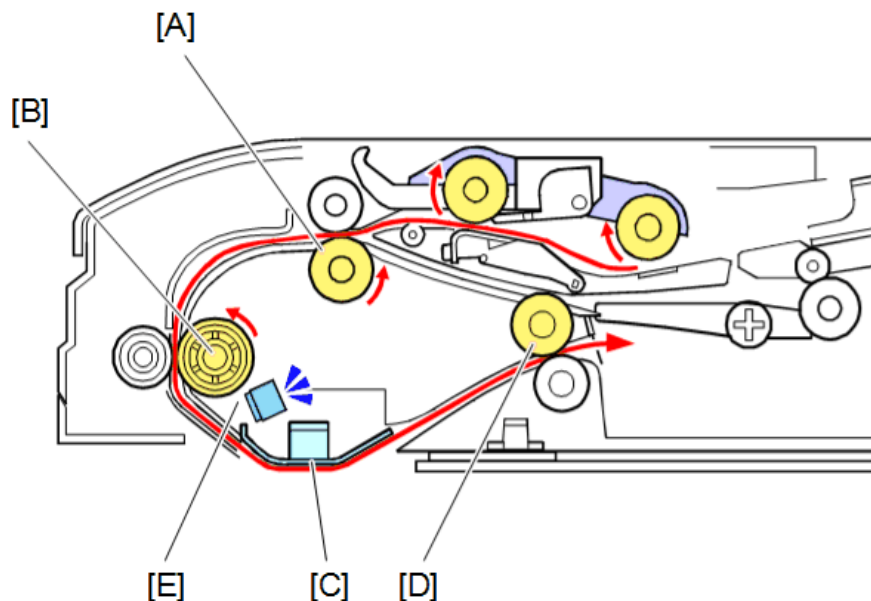

d205c9025

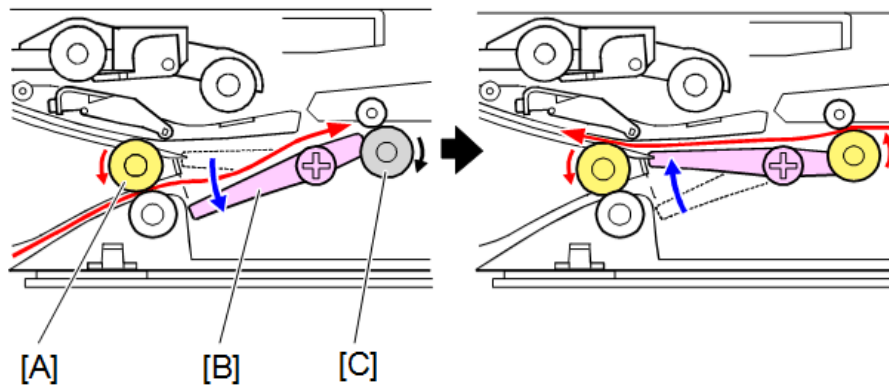
**Original Transport (Duplex Scanning)**

d205c9026

An original that is scanned on one side comes out through the original exit roller [A]. However, in duplex scanning, the reverse solenoid turns ON and lowers the junction gate [B], and the original is transported through the reverse roller [C] to the original exit tray.

When the trailing edge of the original has passed through the roller, the reverse solenoid turns OFF and the junction gate is lifted. The reverse roller rotates in the opposite direction to send the original back to the 1st transport roller for scanning of the second side.

## 6.4 IMAGE PROCESSING

### 6.4.1 BLOCK DIAGRAM

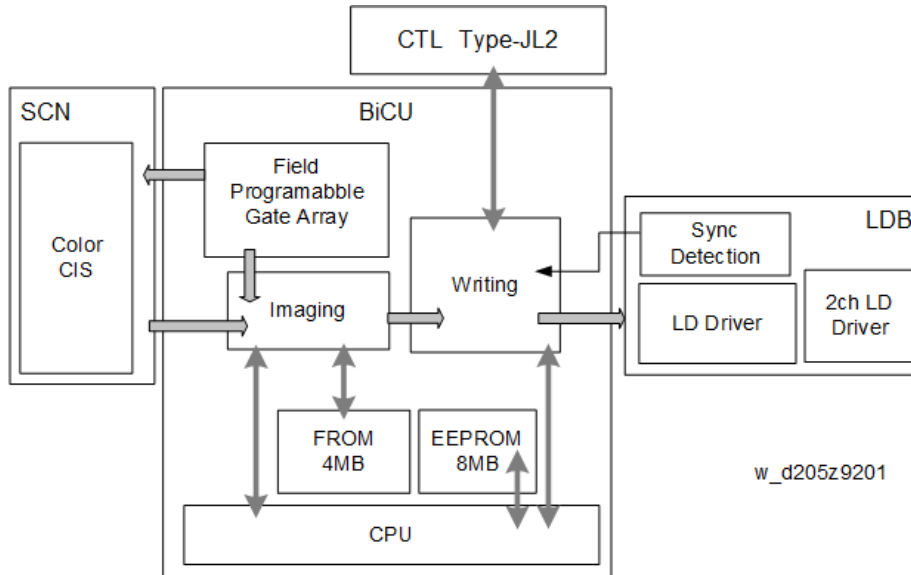

### 6.4.2 OVERVIEW

#### **CIS Unit**

##### **Functions**

Performs Black level correction and White level correction (AGC), and A/D conversion.

##### **Operation Overview**

Converts the six-channel analog RGB signals, generated by a line-sequential CIS (Contact Image Sensor) unit to a 10 bit digital signal at the AFE (analog front end) on the CIS unit; and generates the digital signals for the BiCU as an LVDS signal.

##### **SP Correction Value Storage**

The following CIS correction values are stored in an EEPROM on the BiCU. They must be re-adjusted after the CIS unit is replaced.

- SP4-008-001 (Sub Scan Magnification Adj)
- SP4-010-001 (Sub Scan Registration Adj)
- SP4-011-001 (Main Scan Reg)
- SP4-688-001 (DF Density Adjustment ARDF)

##### **Note**

- **Dirty Background Adjustment When Using DF:**  
The image density scanned by using the DF may be lower compared to the image density scanned by using the platen. The image density value of DF scanning can be adjusted by SP4-688-001 (DF Density Adjustment ARDF).

**BiCU****Image processing function overview**

The image signals from the CIS unit are subjected to various image processing, and output to the controller (memory) via a PCIe bus. The image signals from the controller (memory) are received via the PCIe bus, and output to the LDB via a GAVD (the LDB is provided in the laser unit).

The image signals from the CIS unit are subjected to various image processing, and output to the FCU via the PCIe bus (for direct fax application transmission).

**Image processing overview (copy application)**

Digital signal data output from the CIS unit is subjected to shading correction and line interval correction, as well as image processing, which are performed by the BiCU. Finally, the data is sent to the MFP unit as digital signals-2 bit/pixels.

Image processing items	Details
Shading correction	Corrects for uneven scanner lamp lighting
Line interval correction	Line shift during sub-scanning magnification/reduction by scanner. Corrects integer part.
Dot correction	Line shift during sub-scanning magnification/reduction by scanner. Corrects below decimal point.
Vertical line correction	Corrects a vertical striped image during sheet-through ARDF.
Image area separation	Determines text parts and photo parts of image.
Scanner gamma correction	Corrects scatter of image data relative to exposure amount. From reflectivity linear to density linear.
Filter	Performs image sharpness adjustment and removes moire.
ADS	Performs natural complexion removal in full color mode.
Color compensation preprocessing	Determines hue in masking mode, and improves chromaticity.
Color compensation	Converts RGB data to density value CMYK data of color materials.
Image magnification change	Arbitrarily changes main scanning magnification, sub-scanning fixed image reduction and magnification of scanner image.

Image processing items	Details
Image shift function	Shifts image data in the main scanning or sub-scanning directions.
Image binarization function	In scanner mode, outputs a binary signal.
Image mask	Masks an area outside a frame of an arbitrary region in scanner or printer data.
Image compression/expansion	Compresses or expands an image.
Printer gamma correction	Adjusts exposure amount of photosensitive body relative to image density.
Gradation processing	Applies 600dpi, 4bit 16 value gradation processing.

### 6.4.3 RELATED SPS

- **SP4-688-001 [DF Density Adjustment ARDF]:**  
Adjusts the density gradient between the book mode and ARDF mode.

## 6.5 LASER EXPOSURE

### 6.5.1 OVERVIEW

This model uses the two beam laser system. This system allows the machine to reduce the polygon motor's speed, which enhances the machine's quietness in use.

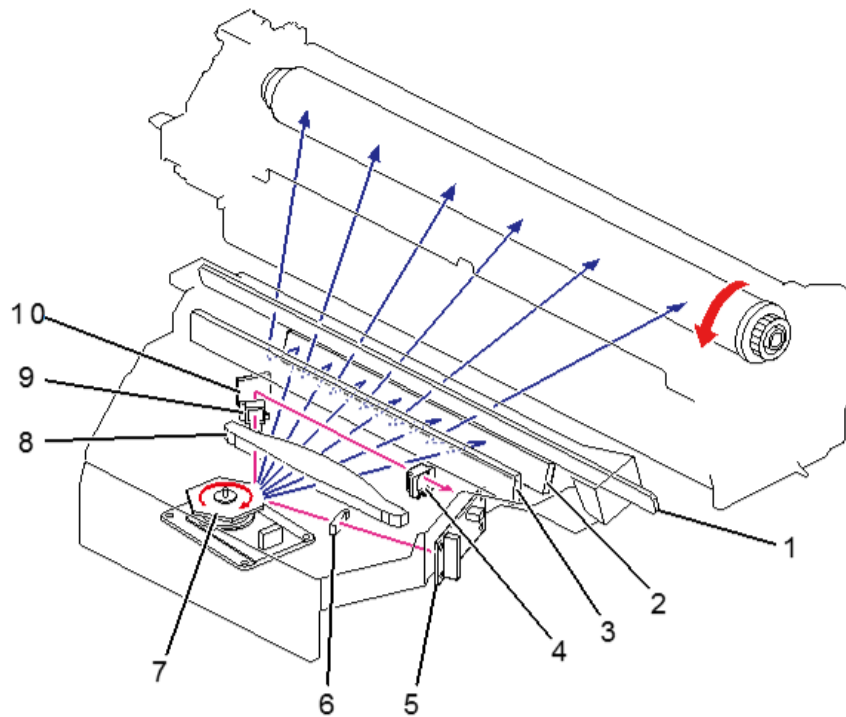

d205c9029

No.	Items	No.	Items
1	Dust Shield Glass	6	Cylindrical lens
2	Mirror	7	Polygon Motor
3	Mirror	8	F-theta lens
4	Lens 2	9	Lens 1
5	LD Board	10	Mirror

#### ⓘ Note

- The LD drive board controls both the laser output and laser synchronization mechanism.
- The machine cuts off the power supply to the LD drive board if the front or right cover is opened.

## 6.5.2 AUTO POWER CONTROL (APC)

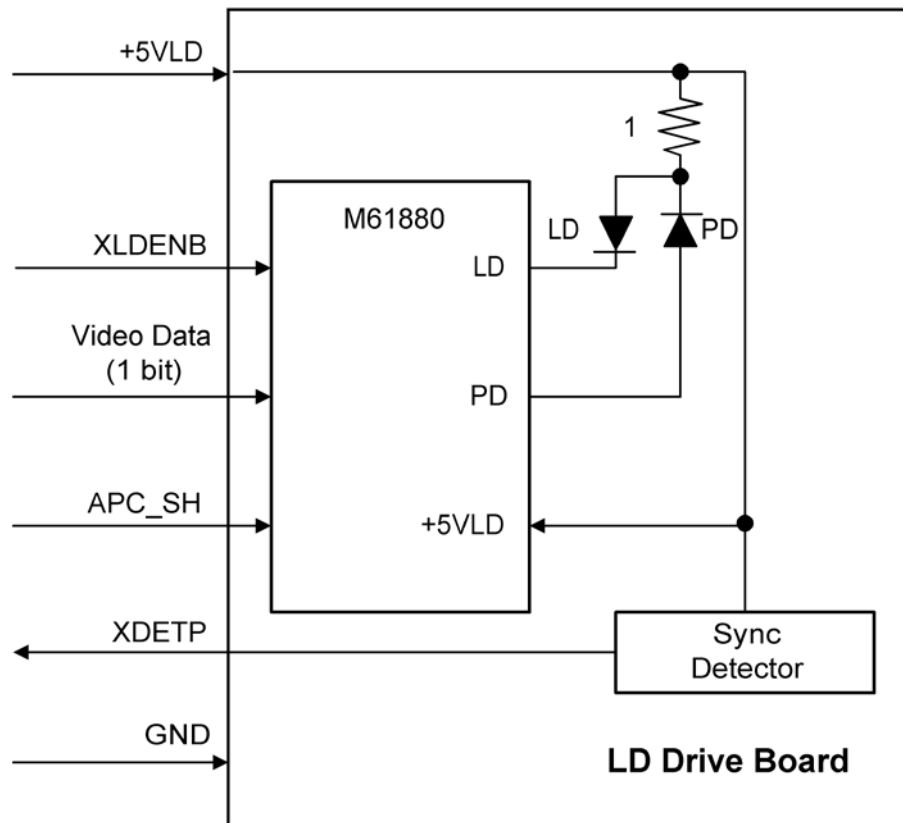

The LD driver IC drives the laser diode. To prevent the intensity of the laser beam from changing because of the temperature, the machine monitors the current passing through the laser diode (LD). The machine adjusts the current to the laser diode by comparing it with the reference level from the reference circuit.

This auto power control is done just after the main power is turned ON and during printing.

The laser diode power is adjusted on the production line.

### ⓘ Note

- Do not touch the variable resistors on the LD unit in the field.



### 6.5.3 LD SAFETY SWITCH

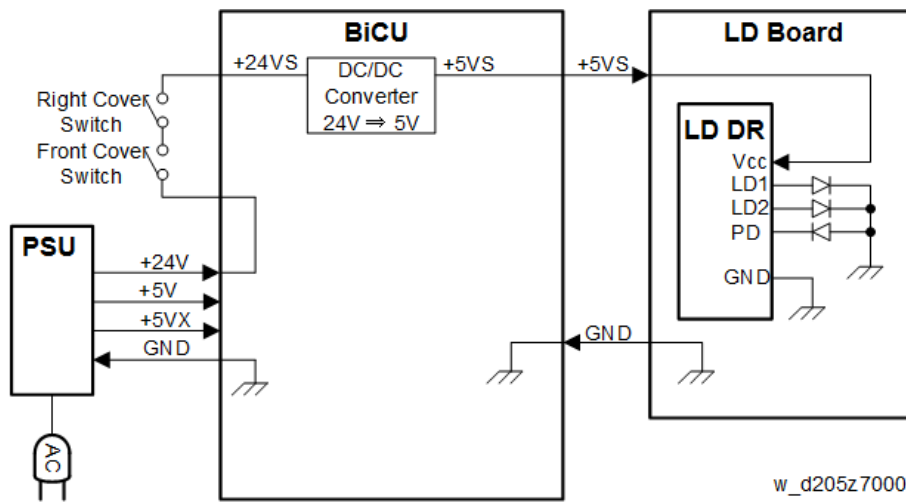

To ensure technician and user safety and to prevent the laser beam from inadvertently switching on during servicing, safety switches are located at the front and right covers. The switches are installed on the +5VLD line through the BICU board.

When the front cover or the right cover is opened, the power supply to the laser diode is interrupted.

## 6.6 PCU

### 6.6.1 OVERVIEW

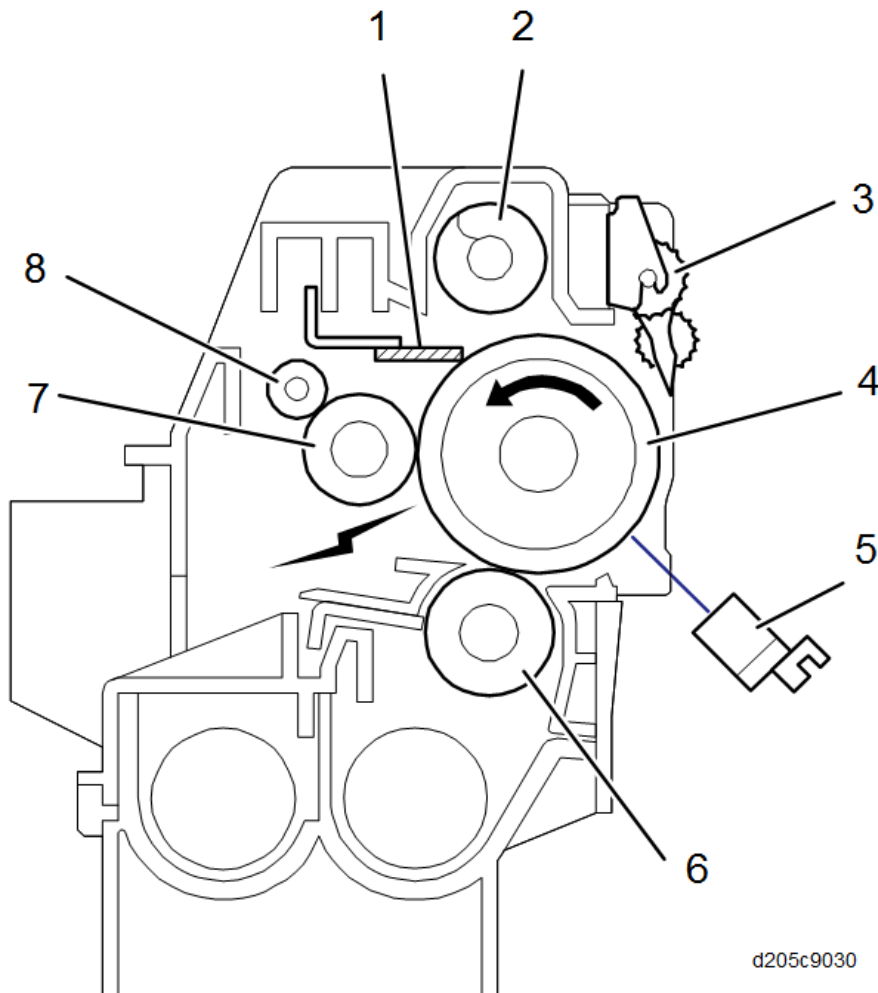

Detailed Descriptions

No.	Items	No.	Items
1	Cleaning Blade	5	ID Sensor
2	Toner Collection Coil	6	Development Roller
3	Pick-off Pawl	7	Charge Roller
4	Drum	8	Charge Roller Cleaning Roller

## 6.6.2 MECHANISM

### *Drum Drive Mechanism*

The main motor [C] drives the drum through gear [B] and the drum drive shaft [A]. If the motor speed exceeds the regulation speed, the motor stops for safety.

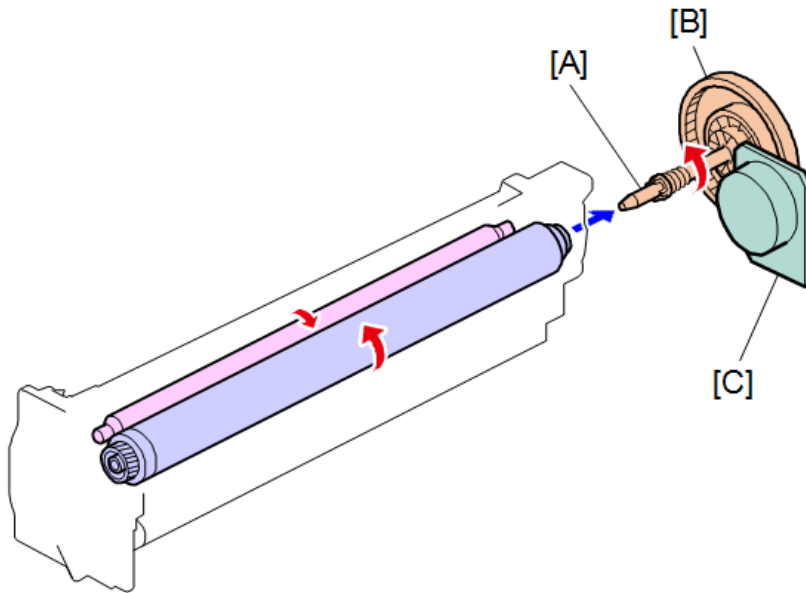

d205c9031

## ***Drum Charge***

Charging the drum is performed by the charge roller [A].

The HVPS applies the bias to the charge roller via a receptacle and electrode terminal. The charge roller is always in contact with the surface of the drum with the pressure spring and applies a charge bias.

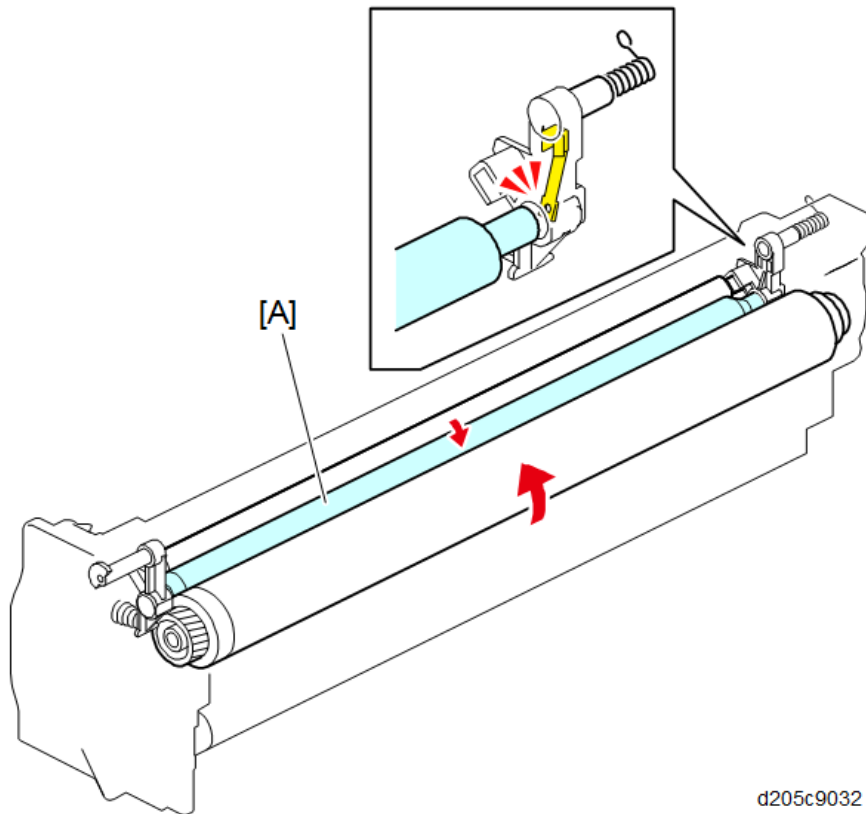

d205c9032

### Charging Bias Correction (Environmental Correction)

With a drum charge roller system, the voltage transferred from roller to drum varies with the temperature and humidity around the charge roller. The higher the temperature or humidity is the higher the applied voltage required.

To compensate, the machine uses the ID sensor to measure the effects of current environmental conditions. For this measurement, the process control parameters are balanced so that any small change in drum potential caused by environmental effects is reflected in a change in the amount of toner transferred to the drum.

This correction is made immediately after the ID sensor pattern for toner density control.

Immediately after making ID sensor pattern [A], the development bias stays the same (-340 V), but the charge roller voltage goes up to -1450 V; as a result the drum potential is reduced to -650 V. The laser diode is not switched on, and the drum potential is now slightly higher than the development bias, so a very small amount of toner transfers to the drum. The ID sensor measures the density of this pattern [B], and the output voltage is known as  $V_{sdp}$ . This voltage is compared with  $V_{sg}$  (read from the bare drum at the same time).

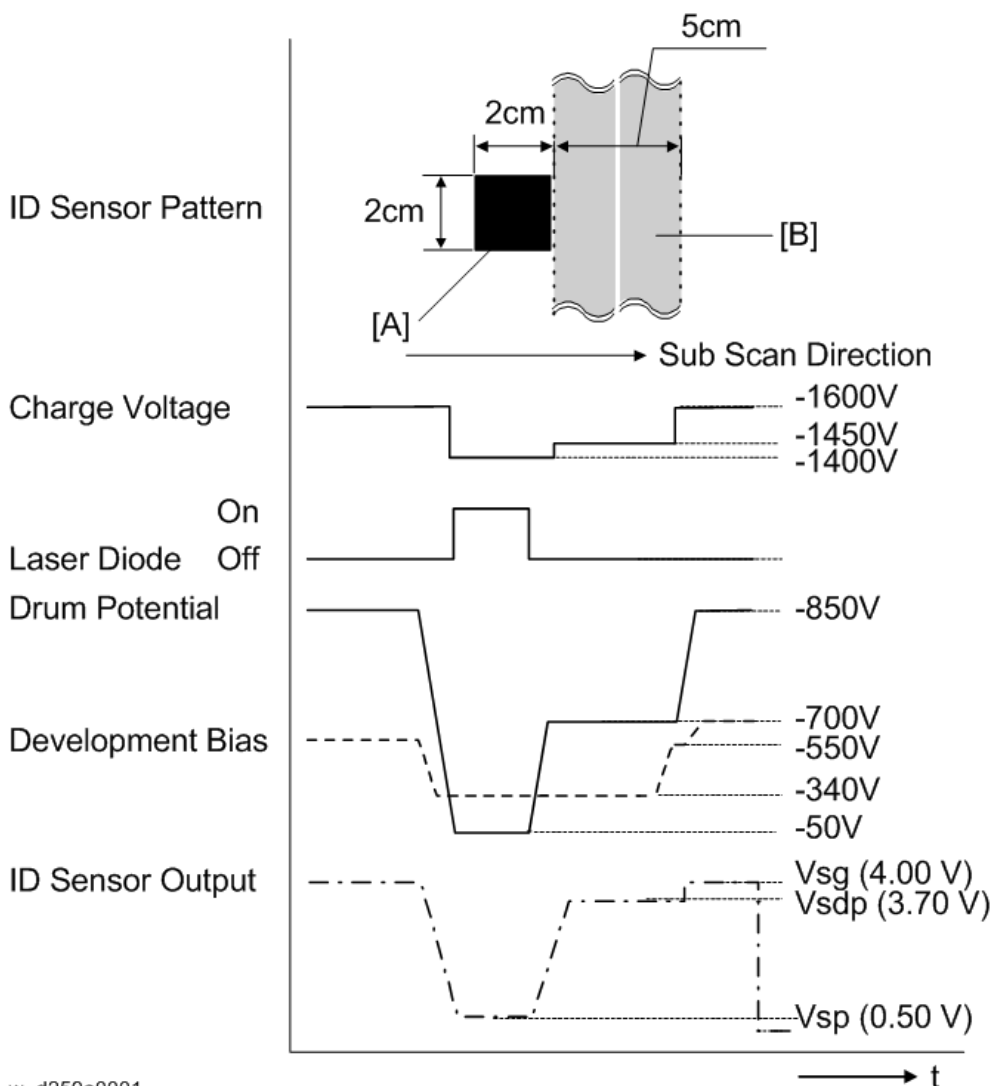

w\_d259a0001

If the humidity drops, the drum potential goes up (to a higher -ve voltage) even if the charge roller voltage supply stays the same (efficiency of voltage transfer is higher with lower humidity). As a result, less toner is transferred to ID sensor pattern [B]. If the sensor output reaches a certain point, the drum charge voltage will be reduced.

To determine whether to change the drum charge roller voltage, the machine compares  $V_{sdp}$  with  $V_{sg}$ .

$V_{sdp}/V_{sg} > 0.95$  = Make the drum charge voltage less -ve (smaller) by 50 V

$V_{sdp}/V_{sg} < 0.90$  = Make the drum charge voltage more -ve (larger) by 50 V

### ***ID Sensor***

The ID sensor is used to keep image density constant by monitoring the density of a standard sensor pattern. Based on the ID sensor readings, the machine adjusts the development bias, drum potential and LD power.

The ID sensor does not check each page or each job. The ID sensor check is done at the following times:

- When the machine is warming-up at startup.
- When recovering from sleep mode or energy saving mode, and ID sensor control temperature (measured by the internal temperature sensor) is below a certain value. (Initial setting: 30°C)

### ***Cleaning the Charge Roller***

Dirt can easily adhere to the charge roller [B] because the roller is always in contact with the drum with the pressure spring. Therefore, the charge roller cleaning roller [A] is always in contact with the charge roller [B] for cleaning.

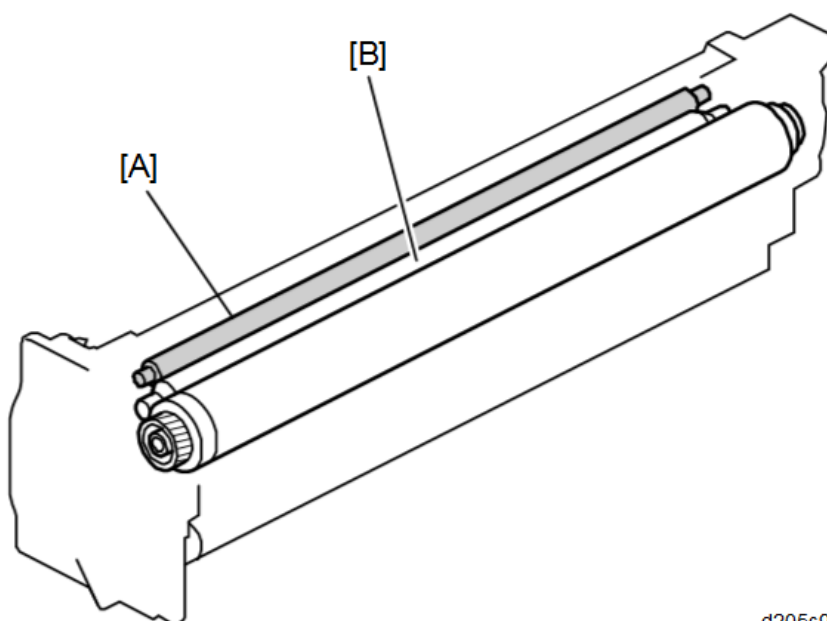

d205c9033

### ***Drum Cleaning***

The cleaning blade [A] removes any toner remaining on the drum after the image is transferred to the paper. This model uses a counter blade system.

The cleaning blade scrapes off toner remaining on the drum. When toner builds up in the cleaning unit, toner at the top of the pile is removed by the toner collection coil [B].

To remove the toner and other particles that are accumulated at the edge of the cleaning blade, the drum turns in reverse for about 6 mm at the end of every copy job.

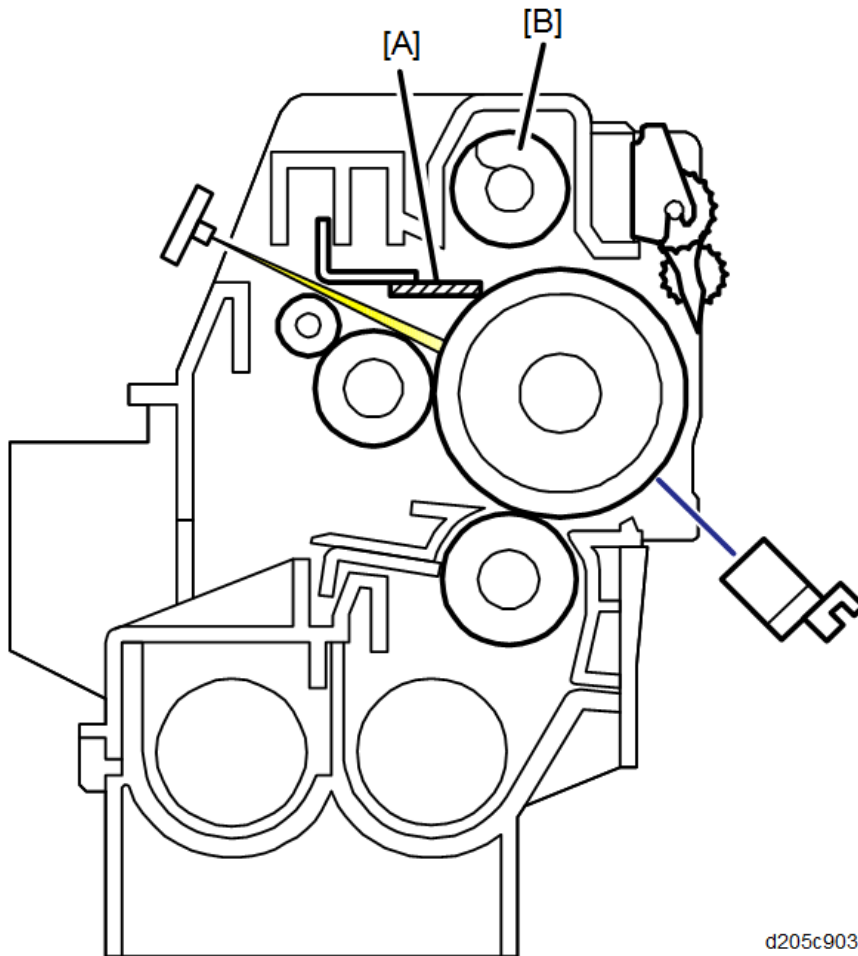

## ***Toner Recycling***

Toner on the drum [D] is scooped by the cleaning blade [C].

Scooped toner is then picked up by the toner collection coil [A] and transported to the opening [B] in the side of the PCU. Then, this toner falls into the development unit with new toner coming from the toner bottle.

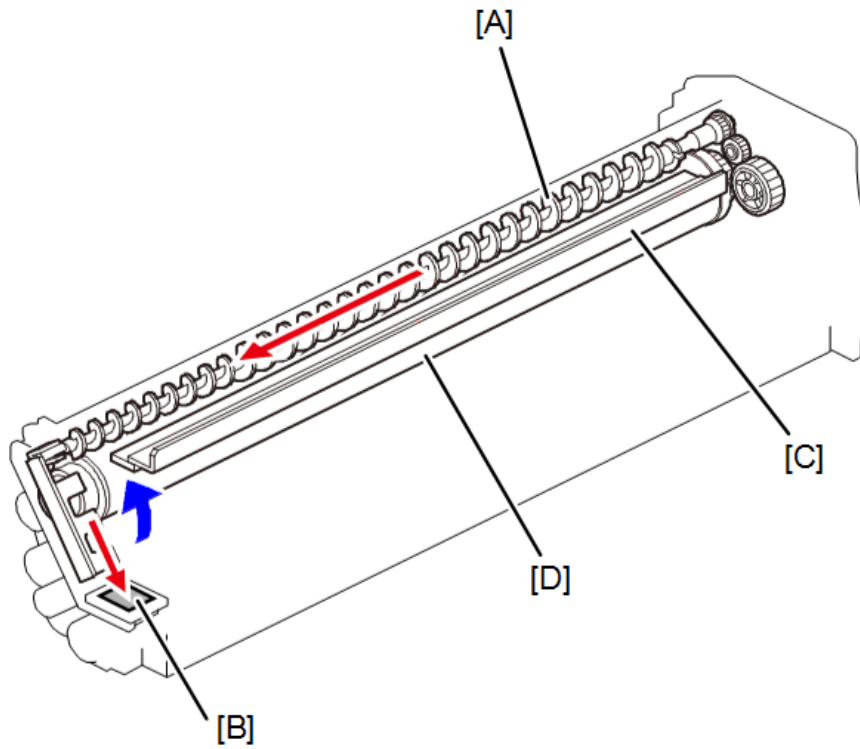

d205c9035



## 6.7 DEVELOPMENT AND TONER SUPPLY

### 6.7.1 OVERVIEW

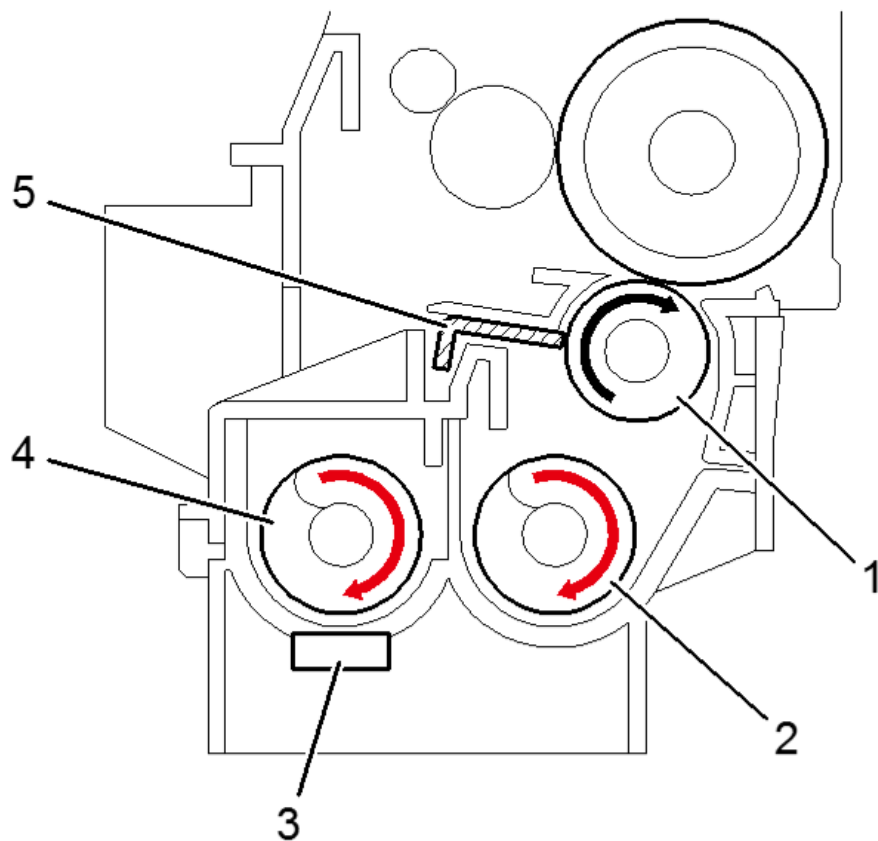

d205c9040

	Part name
1	Development roller
2	Mixing auger 1
3	TD sensor
4	Mixing auger 2
5	Doctor blade

This machine uses a single-roller development system. Two mixing augers mix the developer. The toner density (TD) sensor and image density (ID) sensor (see the illustration in the PCU section) are used to control the image density on the copy.

## 6.7.2 MECHANISM

### *Drive*

The main motor [D] drives the development roller [B] and mixing augers [A] through gear [C] and the development drive shaft.

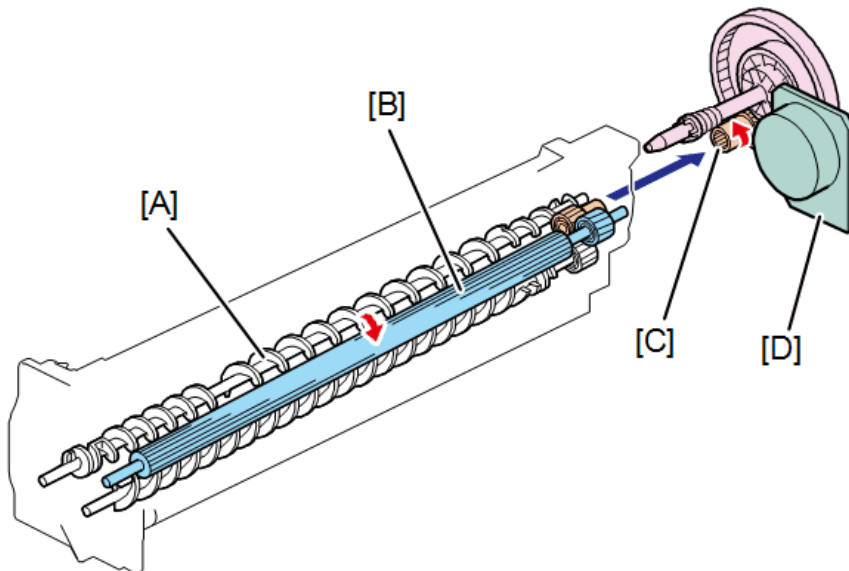

d205c9041

### *Developer Mixing*

The two mixing augers [C] and [D] keep the developer evenly mixed. Mixing auger 1 [D] transports excess developer, scraped off the development roller by the doctor blade [B], towards the front of the machine. Mixing auger 2 [C] returns the excess developer, along with new toner, to the rear of the mixing assembly. Here the developer is reapplied to the development roller.

The TD sensor [A] detects the density of toner inside the developer.

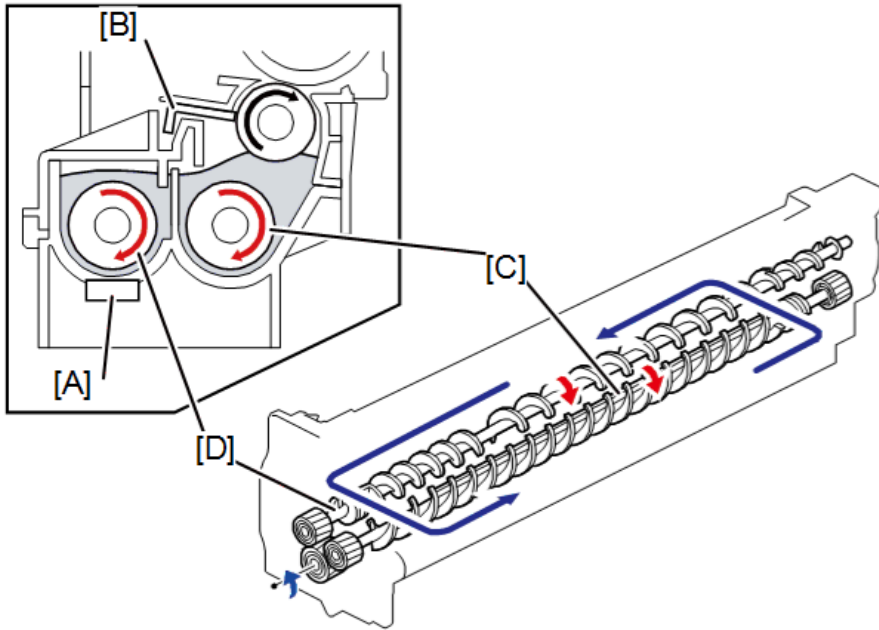

d205c9042

### ***Development Bias***

The bias is applied to the development roller shaft through the carbon terminal [A] and dielectric sheet.

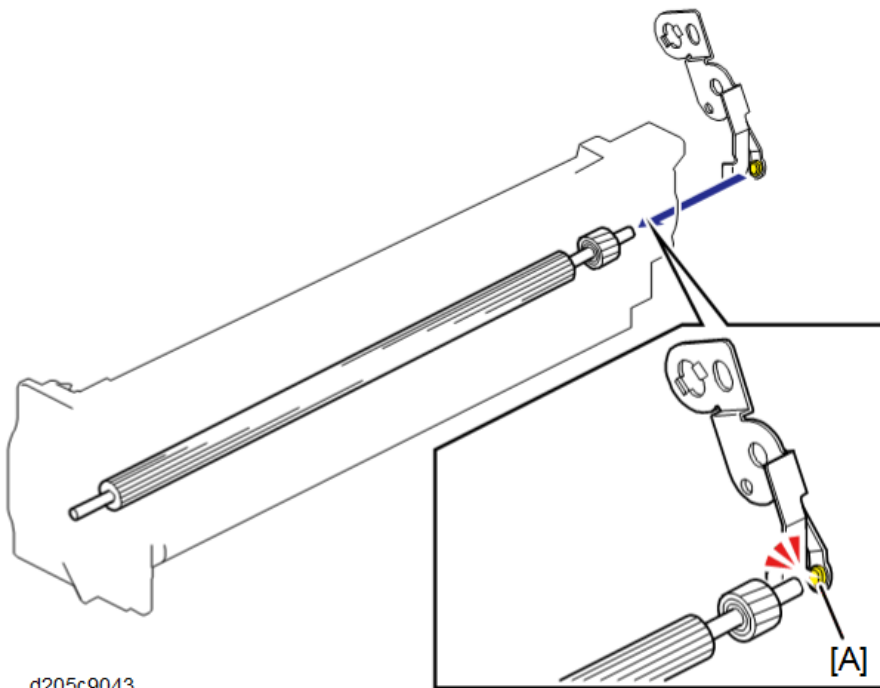

d205c9043

## Toner Supply

When a toner bottle [A] is set, the transporter nozzle [B] is inserted into the bottle.

Toner supply motor drives the mixing auger [C] through gear [D], horizontally transporting the toner inside the toner bottle. Stable and precise toner supply and reduction of remaining toner are achieved through transportation by an auger.

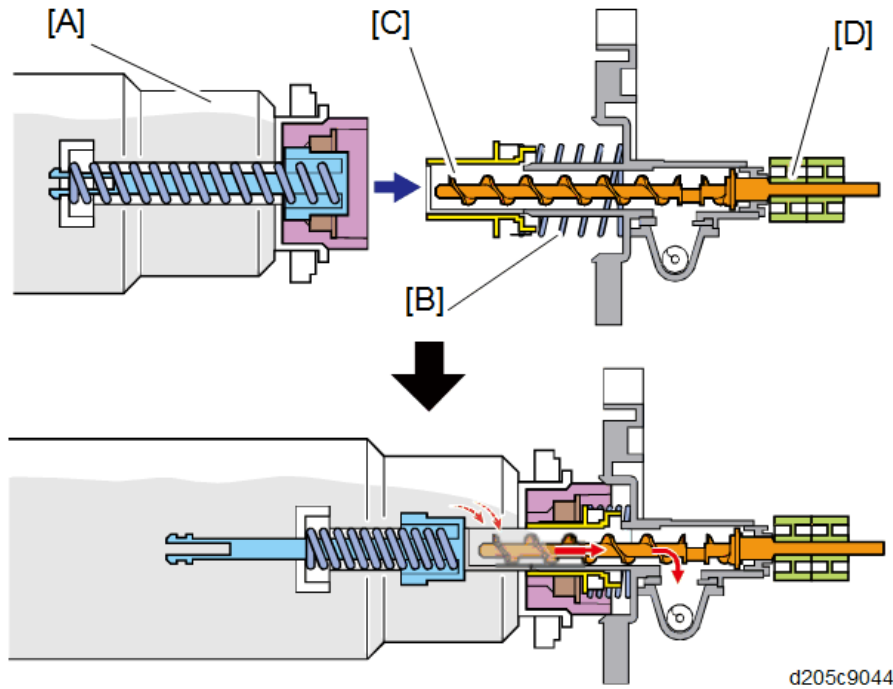

Supplied toner is divided into new toner supplied from the toner bottle and toner collected from the inside of the machine (recycled toner).

New toner transported by the auger [A] passes through the mixing auger and the shutter [D] and falls down into the PCDU through the slit [C]. Recycled toner passes through the inclination in the PCDU and is resupplied into the development unit.

# Development and Toner Supply

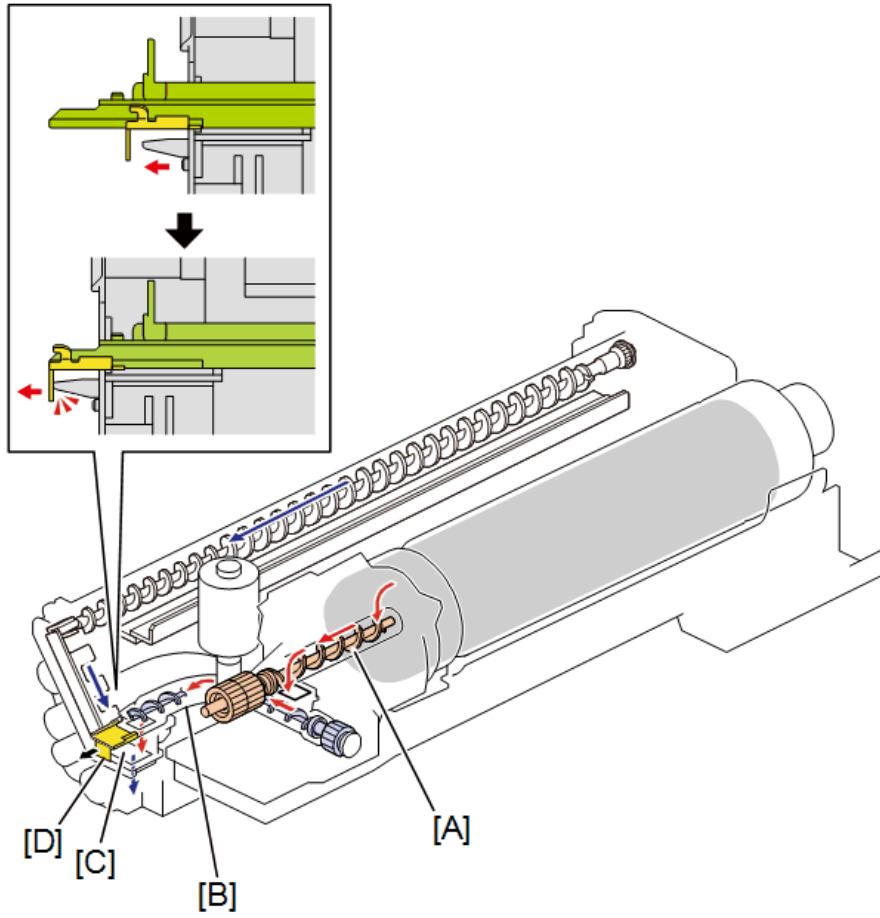

d205c9045

## Toner Density Control

There are four modes for controlling toner supply, which can be changed with by SP2-921-001.

The factory setting is sensor control 1 mode.

Basically, the toner concentration in the developer is controlled using the toner supply reference voltage ( $V_{tref}$ ), actual TD sensor output voltage ( $V_t$ ), and ID sensor output data ( $V_{sp}/V_{sg}$ ).

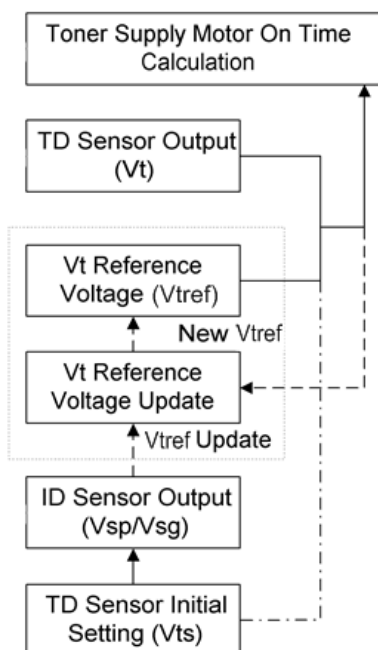

w\_d259a0002

The four-toner density control modes are as follows.

Mode	Sensor control 1 (SP2-921-001, "0"): <b>Normally use this setting only</b>
Toner supply decision	Compare $V_t$ with a reference voltage ( $V_{tref}$ )
Toner control process	<p>Toner is supplied to the development unit when <math>V_t</math> is higher than the reference voltage (<math>V_{tref}</math>). This mode keeps the <math>V_{tref}</math> value for use with the next toner density control.</p> <p><math>V_t</math> is used for the first toner density control after a new PCU has been installed.</p> <p><math>V_{tref}</math> is used after it has been corrected after the ID sensor density control.</p>
Toner supply amount	Varies
Toner end detection	Performed

Mode	Sensor control 2 (SP2-921-001, "1"): For designer's use only
Toner supply decision	Compare $V_t$ with a reference voltage ( $V_{tref}$ )
Toner control process	This toner control process is the same as sensor control 1.
Toner supply amount	Varies
Toner end detection	Performed

Mode	Fixed control 1 (SP2-921-001, "2"): For designer's use only
Toner supply decision	Compare $V_t$ with a reference voltage ( $V_{tref}$ )
Toner control process	This toner control process is the same as sensor control 1.
Toner supply amount	Fixed (SP 2925)
Toner end detection	Performed

Mode	Fixed control 2 (SP2-921-001, "3"): For designer's use only
Toner supply decision	None
Toner control process	Toner is supplied every printed page regardless of $V_t$ .
Toner supply amount	Fixed (SP 2925)
Toner end detection	Not performed

### Toner Supply Motor on Time Determinations

For fixed control mode, the toner supply motor on time is specified by the setting of SP 2925, and does not vary. The default setting is 200 ms for each copy.

For sensor control modes 1 and 2, the toner supply motor on time is decided by the following factors.

- $V_t$
- $V_{tref}$
- TD sensor sensitivity (coefficient: S, value is 0.3)

There are seven levels for toner supply motor on time as shown below.

Level	Mode	Decision $\Delta V_t$ $V_t = V_t - V_{tref}$	Motor On Time (seconds)
0	No supply	$\Delta V_t \leq 0$	0
1	Normal	$0 < \Delta V_t \leq S/16$	T
2	Normal	$S/16 < \Delta V_t \leq S/8$	$a \times t$
3	Normal	$S/8 < \Delta V_t \leq S/4$	$b \times t$
4	Normal	$S/4 < \Delta V_t \leq S/2$	$c \times t$
5	Normal	$S/2 < \Delta V_t \leq 4S/5$	$d \times t$
6	Intermittent (reference: near-end)	$4S/5 < \Delta V_t \leq S$	T
7	Intermittent (reference: toner end)	$S < \Delta V_t$	T

T means that toner is supplied intermittently in a cycle (e seconds on, f seconds off).

The value of "S" can be changed using SP2-931-001 (default: 0.3V)

The value of "t" can be changed using SP2-922-001 (default: 0.2 second)

The value of "T" can be changed using SP2-923-001 (default: 6 seconds)

The value of "a" can be changed using SP2-922-002 (default: 1.5 seconds)

The value of "b" can be changed using SP2-922-003 (default: 2.0 seconds)

The value of "c" can be changed using SP2-922-004 (default: 2.0 seconds)

The value of "d" can be changed using SP2-922-005 (default: 2.0 seconds)

The value of "e" can be changed using SP2-923-002 (default: 0.3 second)

The value of "f" can be changed using SP2-923-003 (default: 0.3 second)

### ***Toner Near End/End Detection and Recovery***

The toner near end and end conditions are detected by the TD sensor.

This is done in all toner supply modes except for fixed mode 2, when toner end is not detected.

#### **Toner Near End Detection**

If toner supply motor on time is at level 6 or higher ten times consecutively, the machine enters the toner near end condition and the toner end indicator starts blinking on the operation panel. Then the machine supplies toner for a certain time, which depends on the setting of SP 2-923-001.

#### **Toner Near End Recovery**

If toner supply motor on time is at level 5 or lower twice consecutively in any of the following situations, the machine clears the toner near end condition.

- While in the toner recovery cycle after the machine has detected a toner near end condition.
- During copying in the toner near end condition.



## Development and Toner Supply

- If the front cover is opened and closed for more than 5 seconds.

### **Toner End Detection**

There are two situations for entering the toner end condition.

- When toner supply motor on time is level 7 three times consecutively while in toner near-end condition.
- When 50 copies\*<sup>2</sup> have been made since entering the toner near end condition.

\*<sup>2</sup> The number of copies between toner near-end and toner end can be changed using SP 2213.

When toner end is detected, the following is performed.

- During paper feed: The machine enters toner end condition as soon as printing on the paper being fed finishes.
- During intermittent toner supply: The machine enters toner end condition as soon as intermittent toner supply finishes.

### **Toner End Recovery**

If the front cover is opened for 5 seconds or more while the main power is turned ON, the machine assumes that the toner bottle has been replaced, and clears the Toner End condition.

### **Toner bottle**

#### **Viewing and printing the log**

Ten most recent toner bottle logs can be viewed with SP7-935-001 through SP7-935-038.

Toner log information can be printed with SP5-991-001.

### 6.7.3 RELATED SPS

- **2-213-001 [Toner End Output Setting]-[0:50 1:20 2:500]:**  
Sets the sheet count for determining a toner-end after detecting a toner near-end.
- **2-921-001 [Toner Supply Mode]-**  
Sets the mode for controlling toner supply.
- **2-922-001 [Toner Supply Time]-[[sec]]:**  
Sets the standard supply time which is determined by the consequences of TD sensor and Vtref
- **2-922-002 [Toner Supply Time]-[Supply Coefficient Level 2]:**  
Sets the standard supply time for Level 2.
- **2-922-003 [Toner Supply Time]-[Supply Coefficient Level 3]:**  
Sets the standard supply time for Level 3.
- **2-922-004 [Toner Supply Time]-[Supply Coefficient Level 4]:**  
Sets the standard supply time for Level 4.
- **2-922-005 [Toner Supply Time]-[Supply Coefficient Level 5]:**  
Sets the standard supply time for Level 5.
- **2-923-001 [Toner Recovery]-[Recovery Time]:**  
Sets the supply time of an intermittent toner when a result of TD sensor detection, a Toner near End and a Toner End are detected.
- **2-923-002 [Toner Recovery]-[Intermittent Supply ON Time]:**  
Sets the time that toner supply motor is activated for intermittent supply.
- **2-923-003 [Toner Recovery]-[Intermittent Supply OFF Time]:**  
Sets the time that toner supply motor is deactivated for intermittent supply.
- **2-925-001 [Fixed Toner Supply Time]:**  
Sets the amount of toner supplied.
- **5-991-001 [Kit Summary Print]:**  
Prints toner log information.
- **7-935-xxx [Toner Bottle Log]:**  
Prints the serial number and attachment date.

## 6.8 IMAGE TRANSFER AND PAPER SEPARATION

### 6.8.1 OVERVIEW

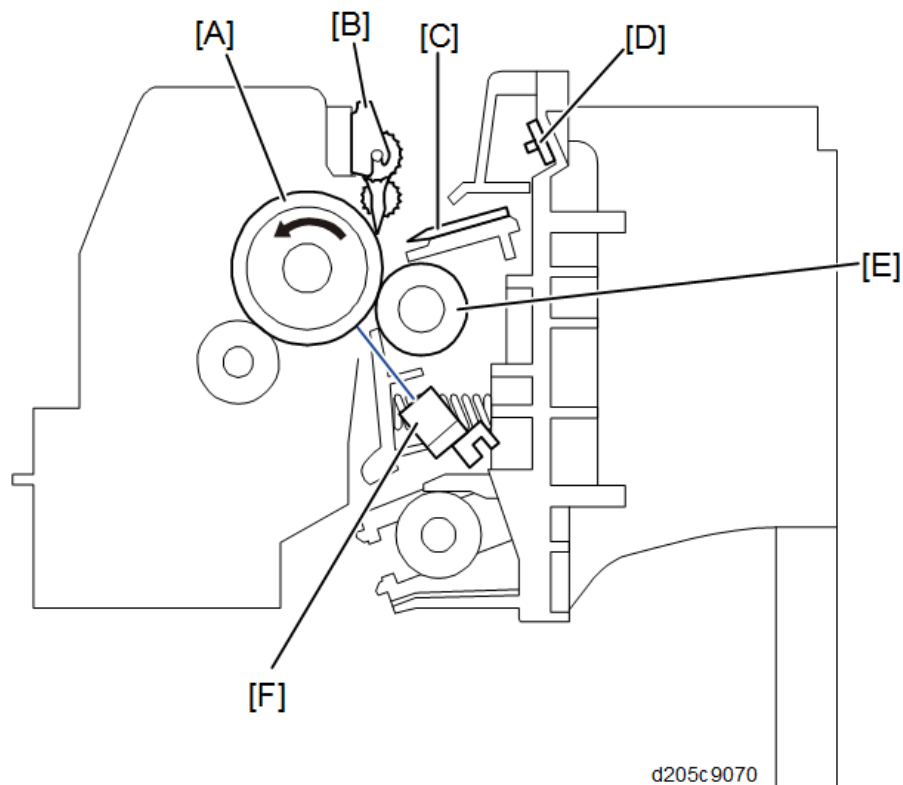

No.	Name	No.	Name
[A]	Drum	[D]	PCL (Pre Cleaning Lamp)
[B]	Pick-Off Pawl	[E]	Transfer Roller
[C]	Discharge Plate	[F]	ID Sensor

The transfer roller [E] touches the surface of the drum [A].

The HVPS supplies a positive current to the transfer roller, which attracts the toner from the drum onto the paper. The PCL (Pre Cleaning Lamp) increases precision of discharge and reduces black streaks on printed sheets.

## 6.8.2 MECHANISM

### *Image Transfer and Paper Separation*

The HVPS [B] supplies a positive current to the transfer roller [C], which attracts the toner from the drum onto the paper.

The discharge plate [A] discharges the current applied onto the paper by applying a negative charge.

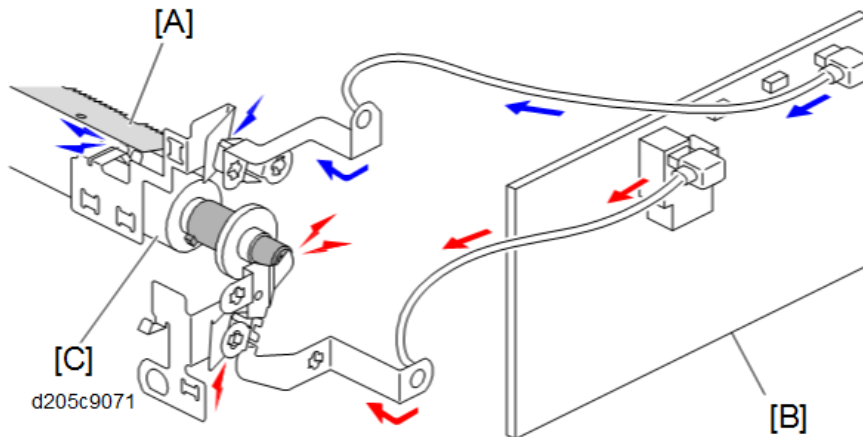

### *Drive*

The main motor [B] drives the drum [A] which rotates the transfer roller [C].

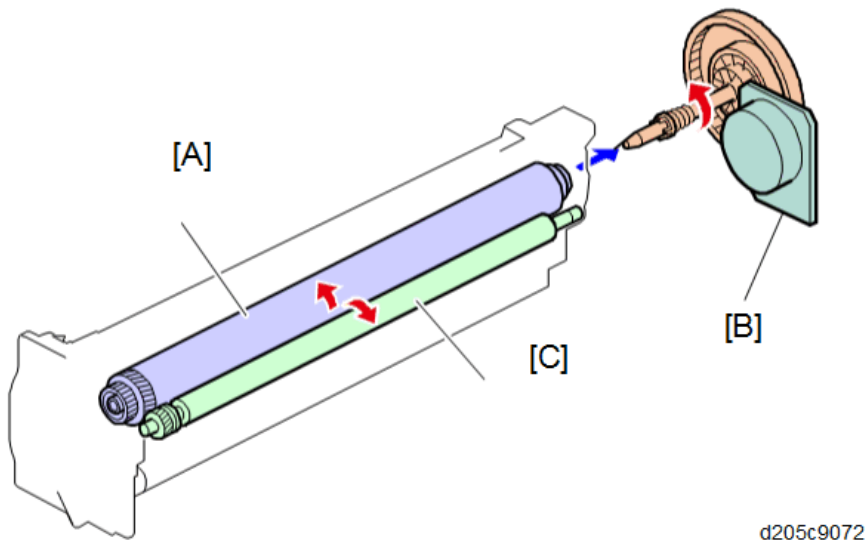

## 6.9 IMAGE FUSING AND PAPER EXIT

### 6.9.1 OVERVIEW

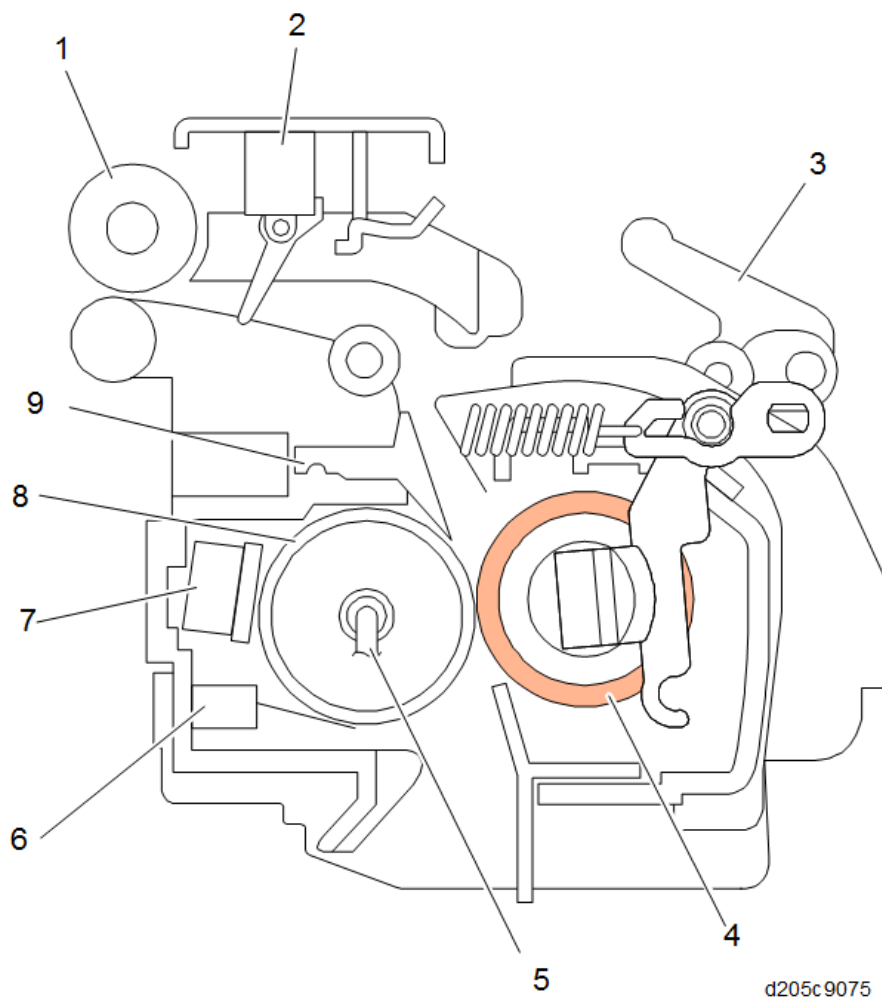

No.	Name	No.	Name
1	Paper exit roller	6	Fusing Thermistor
2	Exit sensor	7	Thermostat
3	Pressure roller adjustment lever	8	Hot roller
4	Pressure roller	9	Hot roller stripper pawls
5	Fusing lamp		

## 6.9.2 MECHANISM

### *Fusing Unit Drive*

#### **Fusing Unit Drive**

The main motor [C] drives the hot roller [A] through the drive gear. Pressure roller [B] rotates together with the hot roller.

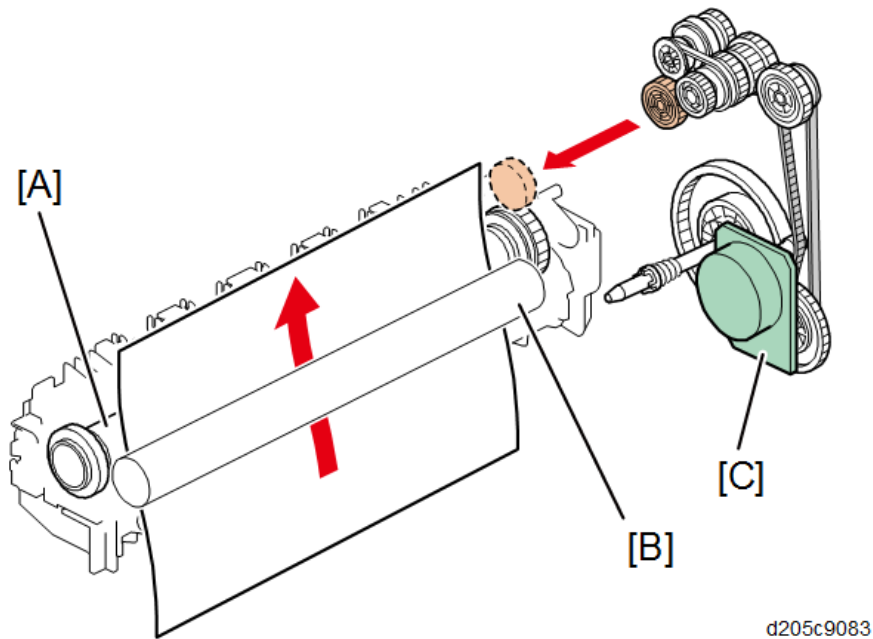

#### **Contact/Release Control**

The drive power is not transmitted to the fusing unit during warming up when the fusing temperature (at the start) is 17 °C or higher. The drive power is transmitted when the fusing temperature is less than 17 °C.

The hot roller takes a shorter time to become hot enough if it is not turning during warming up. When, however, the fusing temperature (at the start) is low, the temperature of the hot-roller surface may become uneven.

SP1-103-001 can disable this control. Do not change this SP to 1 unless there is a problem with offset, because when this SP is set to 1, the fusing unit 'reloads' and warm-up time becomes longer than specification (17.6 seconds).

#### **Drive Release Solenoid**

When the right cover is closed, the drive gear [B] engages with the fusing unit drive gear [D]. When the fusing solenoid [A] is on, the tip of the fusing bracket [C] is pulled up. As a result, the drive gear is released from the fusing unit drive gear.

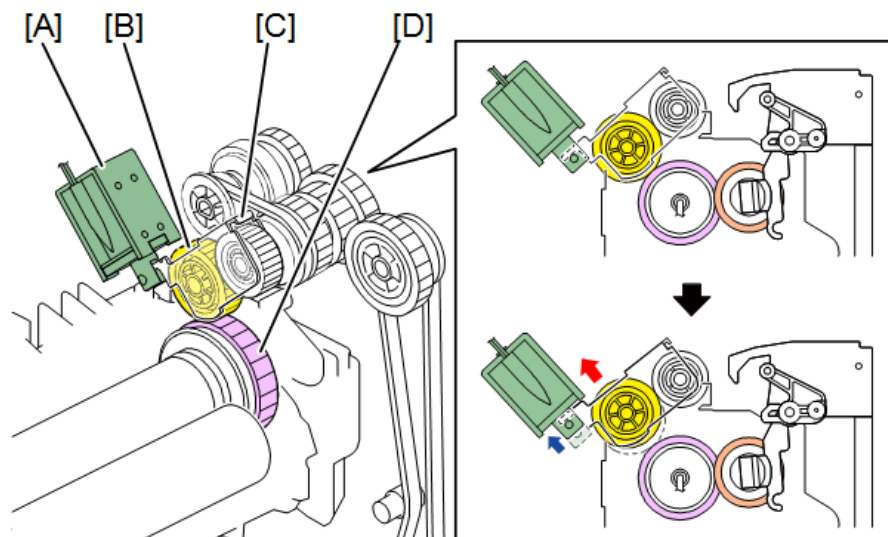

d205c9082

When the fusing temperature is 17 °C or higher, the release solenoid comes on when you turn ON the main power. The solenoid releases the drive gear from the fusing unit drive gear.

### ***Fusing Entrance Guide Shift***

The entrance guide [A] is adjustable for paper thickness to prevent creasing.

If creasing occurs frequently in the fusing unit, move the entrance guide to the side of the gear, by securing it with the holes on the opposite side of the gear.

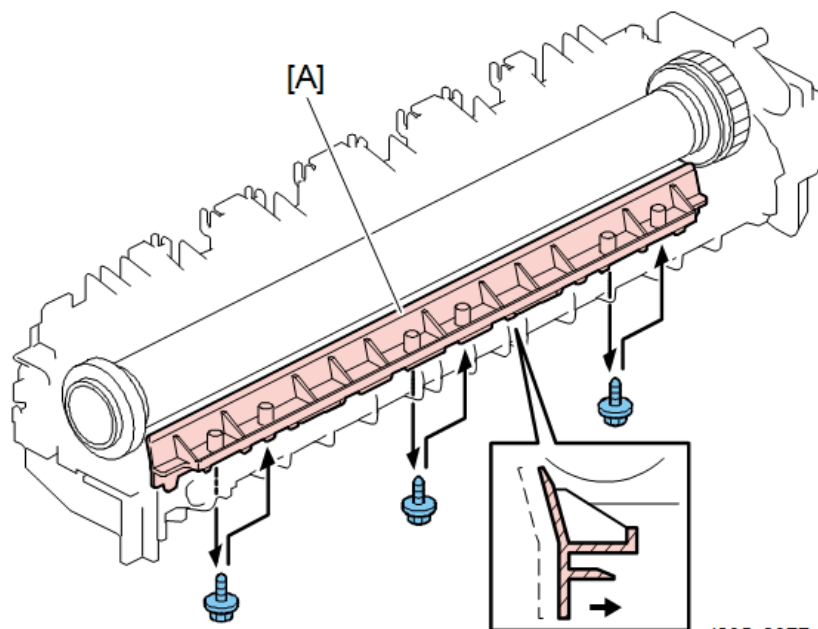

d205c9077

### **Pressure Roller**

The pressure springs constantly apply pressure between the hot roller and the pressure roller.

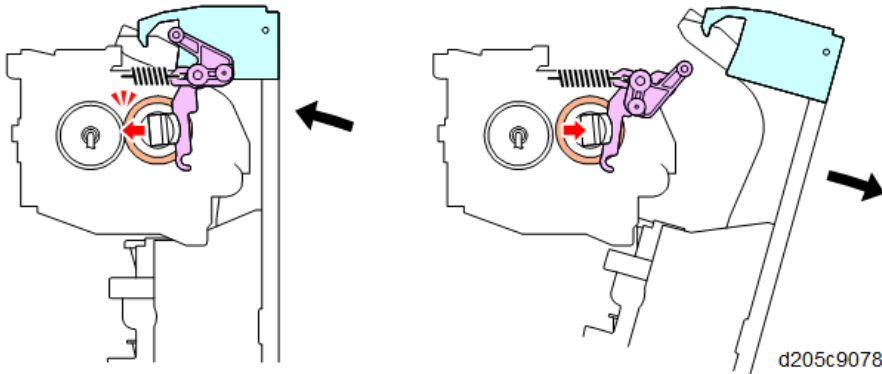

### **Fusing Temperature Control: Fusing Thermistors**

The fusing temperature is controlled using the fusing thermistors [A].

The CPU checks the output from the fusing thermistor once every second. The CPU decides how long the lamps must be switched on during the next second by comparing the temperature of the fusing thermistor and the target temperature.

The fusing lamp works to maintain a target fusing temperature of 145 °C (when plain paper is used) during copying.

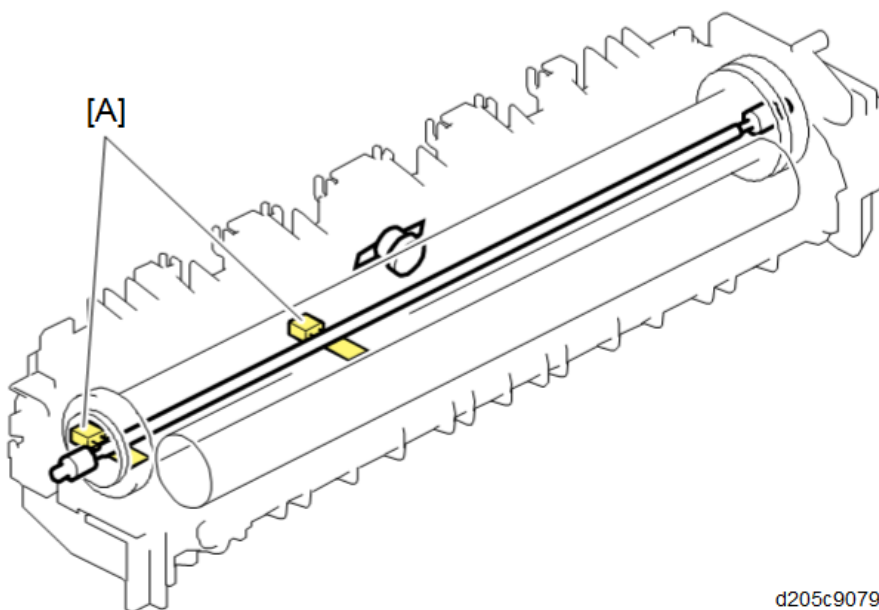

#### **A: Fusing Thermistors**

The fusing thermistor (center) is for the fusing lamp (860 W). The fusing thermistor (end) is for various controls.



## Temperature Control

According to the operation mode, the fusing temperature is controlled. The diagram illustrates the transition of fusing temperature.

- Between Main Power On and Paper Feed

After the main power is turned ON, the fusing temperature rises from the room temperature to a specified temperature (t3).

After the temperature reaches t2, the machine keeps t3 until copying and printing are possible and paper feed starts.

At the beginning of paper feed, additional heat is applied and the temperature is higher than the specified fusing temperature (t1) which differs depending on paper thickness.

The temperature is gradually lowered until it reaches the specified fusing temperature (t1).

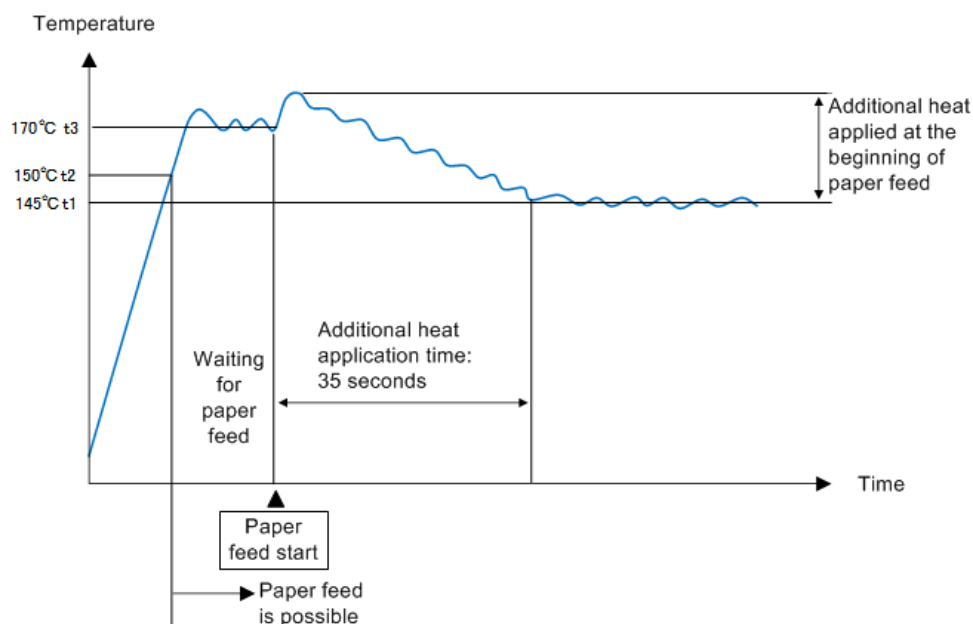

w\_d259a0003

- Between Standby and Paper Feed

In standby mode, the fusing temperature is maintained at t4 (SP1-105-012).

If the operation panel or ARDF is operated during standby, the fusing temperature is maintained at t3 and kept at t3 until paper feed starts.

At the beginning of paper feed, additional heat is applied and the temperature is higher than the specified fusing temperature (t1) which differs depending on paper thickness.

The temperature is gradually lowered until it reaches the specified fusing temperature (t1).

The additional heat applied differs according to the difference between the temperatures of fusing thermistor (center) and fusing thermistor (end) measured at the beginning of paper feed.

When the difference is 25 °C or more: 35 °C is added.

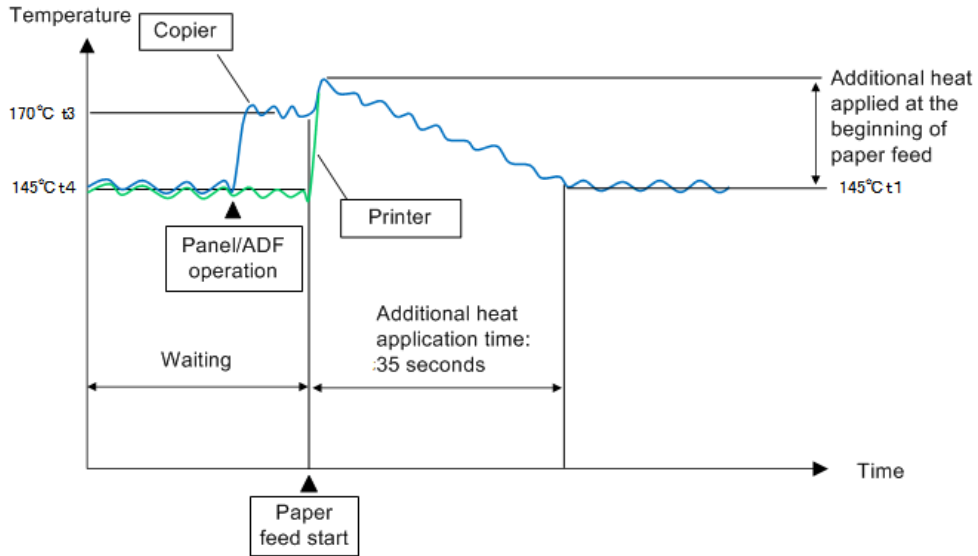

w\_d259a0004

When the difference is less than 25 °C: 5 °C is added.

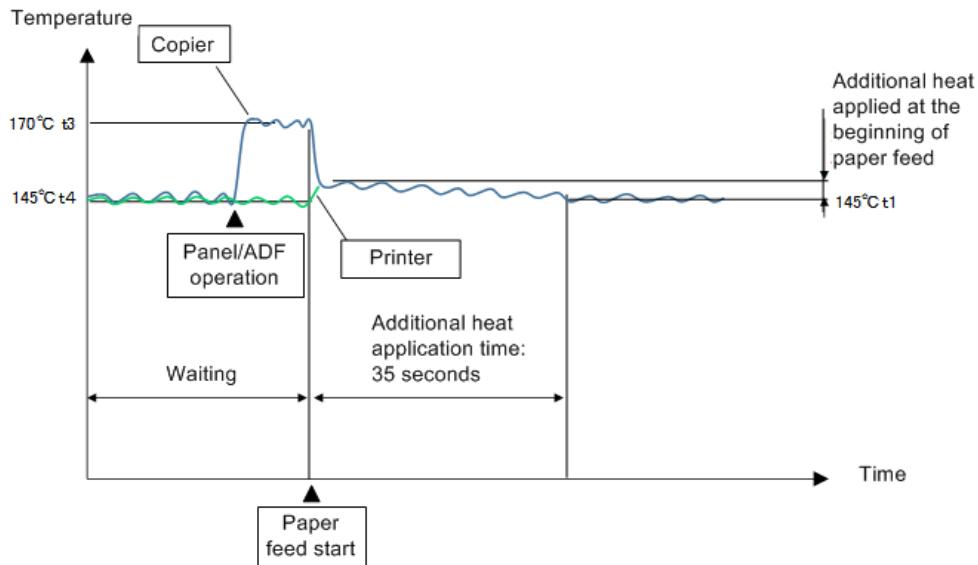

w\_d259a0005

Detailed Descriptions

**Fusing temperature and process speed of each paper type**

The fusing temperature differs according to paper type. When printing on Middle Thick or Thick Paper and when printing in silent mode, the process speed is lowered.

	Paper Thickness	Fusing temperature	SP No.	Process speed
Standard mode	Thin Paper (52 – 59 gsm)	135 °C	SP1-105-009	Normal speed: 136 mm/s
	Plain Paper (60 – 81 gsm)	145 °C	SP1-105-001 (Plain Paper 1) SP1-105-003 (Plain Paper 2)	

## Image Fusing and Paper Exit

	Paper Thickness	Fusing temperature	SP No.	Process speed
	Middle Thick (82 – 105 gsm)	145 °C	SP1-105-005	Low speed: 100 mm/s
	Thick Paper 1 (106 – 135 gsm)	155 °C	SP1-105-007	
	Thick Paper 2 (136 – 162 gsm)	160 °C	SP1-105-048	
Silent mode	Thin Paper	130 °C	SP1-105-065	
	Plain Paper	140 °C	SP1-105-063 (Plain Paper 1) SP1-105-064 (Plain Paper 2)	

### Fusing temperature during Standby and Energy Saver modes

The fusing temperature during Standby and Energy Saver modes are maintained as follows.

	Fusing temperature	SP No.
Standby mode	145 °C	SP1-105-012
Energy Saver mode	130 °C	SP1-105-062

### If fluorescent lights flicker

Turning ON and OFF the fusing lamp may cause the fluorescent lights to flicker. This problem can be lightened by changing the setting of SP1-135-002 from 0 to 1.

If you do this, fusing capability may decrease because the power supply to the fusing unit is reduced when the fusing lamp is on.

### **Overheat Protection/Thermostat**

The fusing lamp has a thermostat [A]. The thermostat cuts the power supply to the fusing lamp at 200 °C.

The thermostat used in this model has higher thermal responsiveness than those used in previous models have. Therefore, even though the operation temperature is high, the temperature of the hot roller can be kept lower, which is safer.

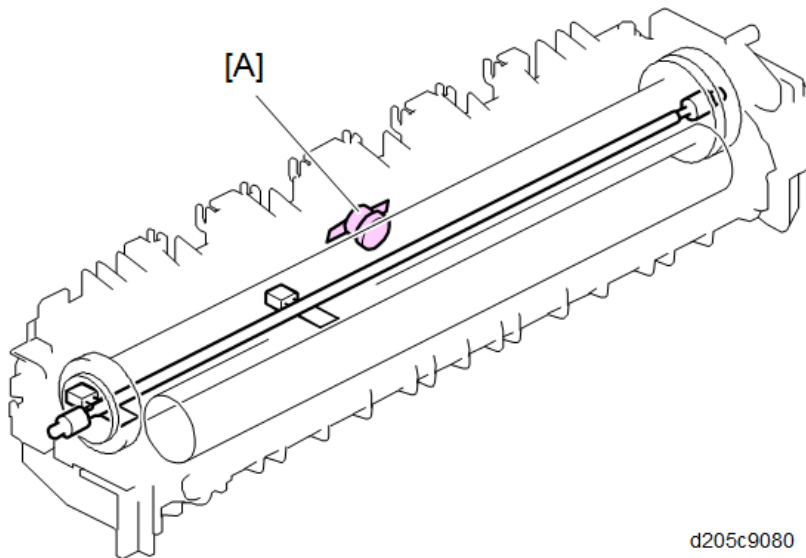

### **Fusing lamp**

This machine uses an 860 W halogen heater [A].

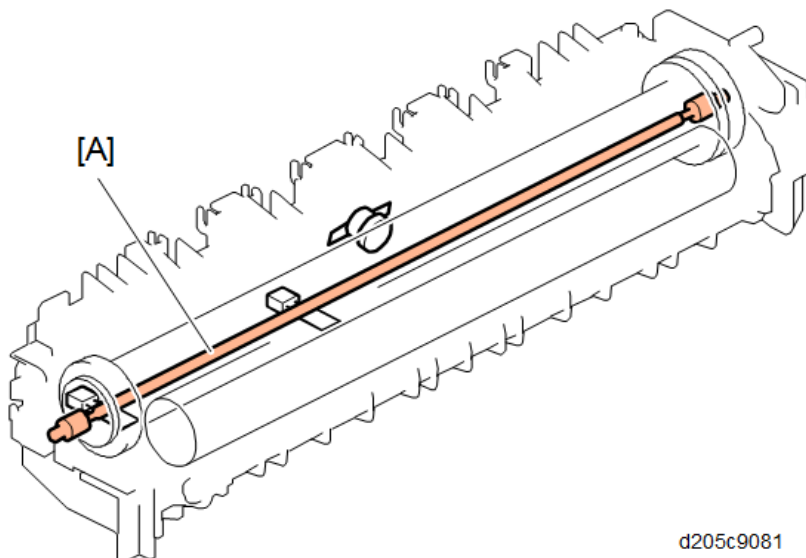

### CPM Reduction

CPM reduction is a mechanism that prevents the machine from abnormal temperature rise in the fusing unit.

When the fusing thermistor (end) detects that the fusing temperature becomes 220°C or higher, the machine reduces the CPM by approx. 30% (from 30 CPM to 9 CPM) by increasing the interval of paper transported in the machine to lower the fusing temperature to the target temperature (145°C).

When the fusing thermistor (end) detects that the temperature becomes less than 220°C at the next job, the CPM reduction is finished and the machine transits to the normal.

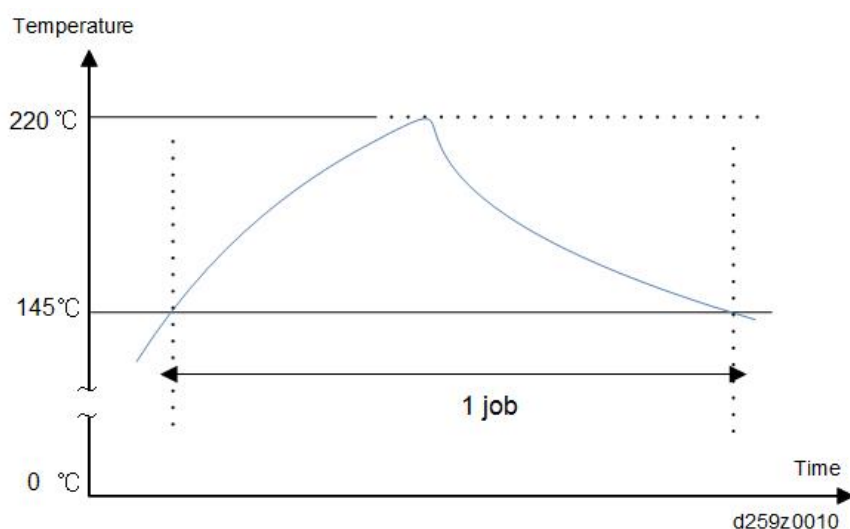

### 6.9.3 RELATED SPS

- **1-105-001, -003, -005, -007, -009 [Fusing Temperature Adjustment Roller Center]:**  
Sets the fusing temperature for Plain Paper 1, Plain Paper 2, Middle Thick, Thick Paper 1, and Thin Paper.
- **1-105-048 [Fusing Temperature Adjustment Roller Center]:**  
Sets the fusing temperature for Thick Paper 2.
- **1-105-063, -064, -65 [Fusing Temperature Adjustment Roller Center]:**  
Sets the fusing temperature for Plain Paper 1, Plain Paper 2, and Thin Paper when printing at low speed.
- **1-135-002 [Inrush/Flicker Control]-[Flicker Control]:**  
Extends the control cycle to make the flicker less noticeable.

## 6.10 PAPER FEED

### 6.10.1 OVERVIEW

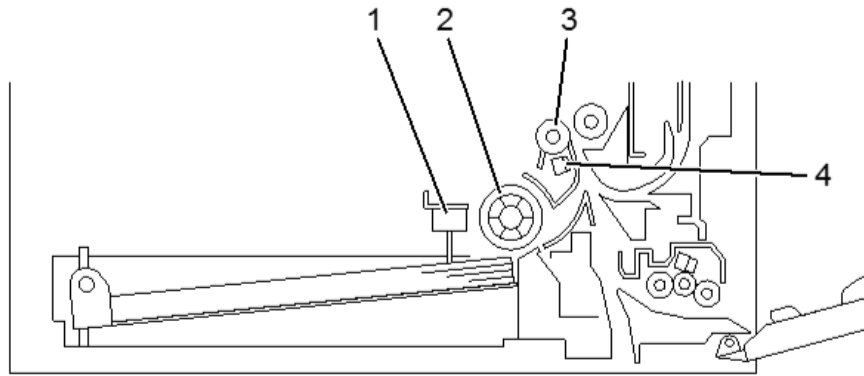

d205c9050

No.	Name	No.	Name
1	Paper end sensor	3	Registration Roller
2	Paper feed roller	4	Registration Sensor

There is one paper tray, which can hold 250 sheets, in the machine.

The paper tray feed stations use a friction pad system.

To prevent paper from getting caught inside the machine when the tray is pulled out, the paper feed roller and shaft do not separate from the tray when the tray is pulled out.

The registration sensor is used for paper jam detection.

## 6.10.2 MECHANISM

### *Paper Feed Drive Mechanism*

The main motor [C] drives the pick-up and feed mechanism. The paper feed clutch [A] transfers drive from this motor to the paper feed roller [B].

When the paper feed clutch [A] turns ON, drive from the main motor [C] is transferred to the feed roller [B]. The paper feed clutch stays on until shortly after the registration sensor has been activated.

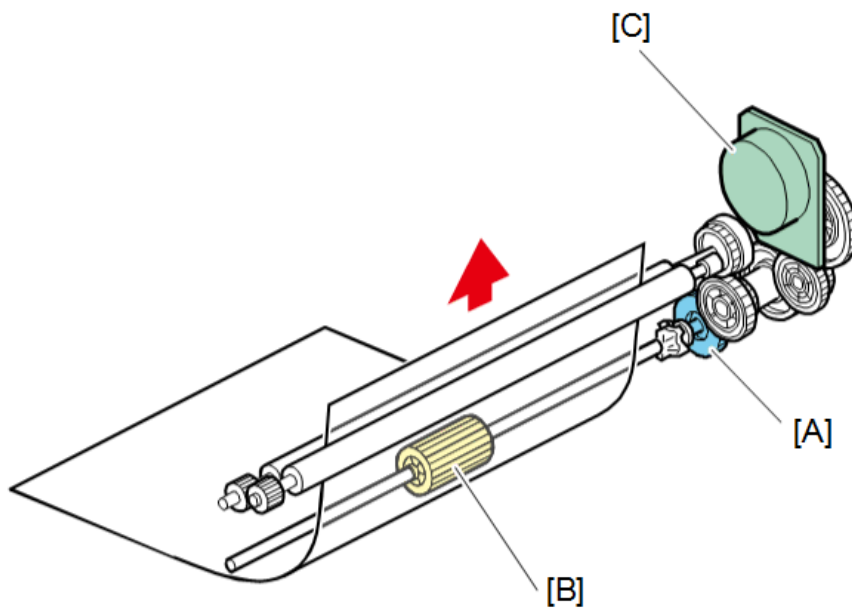

d205c9051

### ***Paper Feed and Separation Mechanism***

The paper feed roller [A] drives the top sheet of paper from the paper tray to the copier. The friction pad [B] allows only one sheet to feed at a time. The friction pad applies pressure to the feed roller with a spring [C].

The friction pad pressure cannot be adjusted.

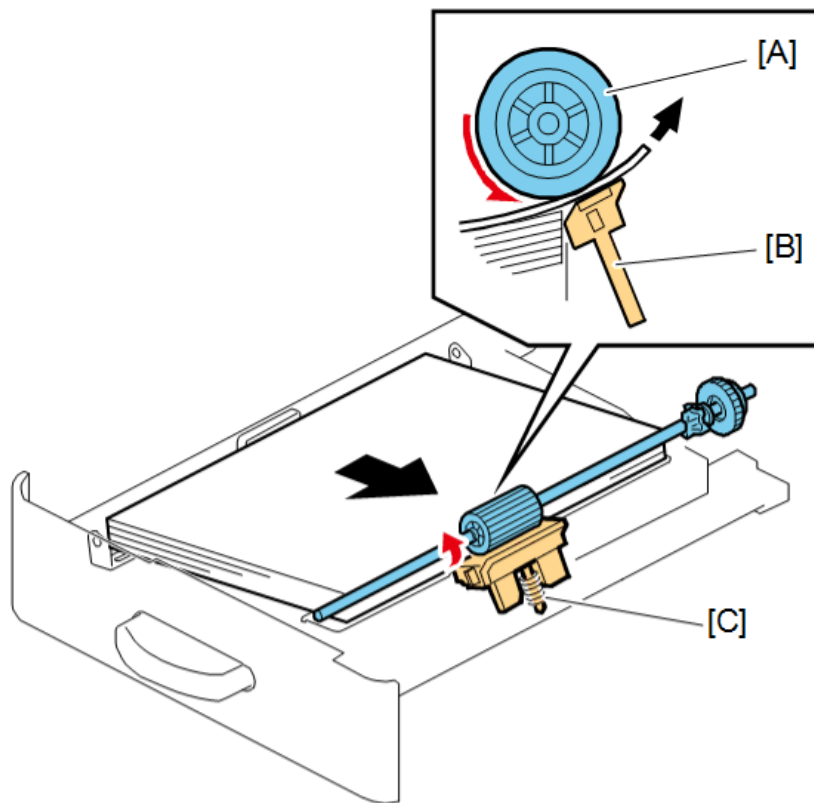

d205c9052



### ***Paper Lift Mechanism***

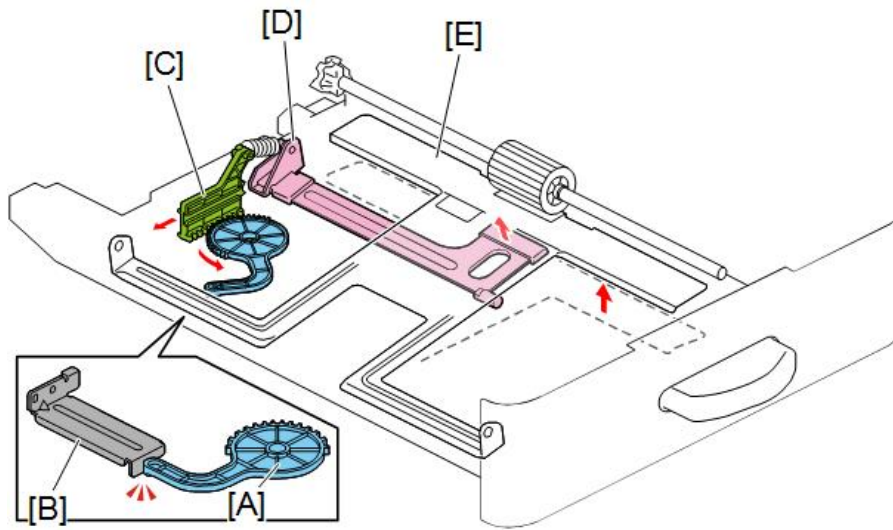

d205c9053

As the tray is inserted to the mainframe, the arm attached to the pinion comes into contact with a component [B] in the mainframe and the pinion [A] rotates gradually. This causes the spring [D] to be pulled by the rack [C] and lifts the bottom plate [E].

### ***Paper End Detection***

When the paper tray runs out of paper, the paper end feeler\*<sup>1</sup> drops into the cutout [A] in the tray bottom plate and the paper end sensor [B] is activated.

\*1 When the paper tray is drawn out with no paper in the tray, the paper end feeler is not caught in the paper tray due to its shape.

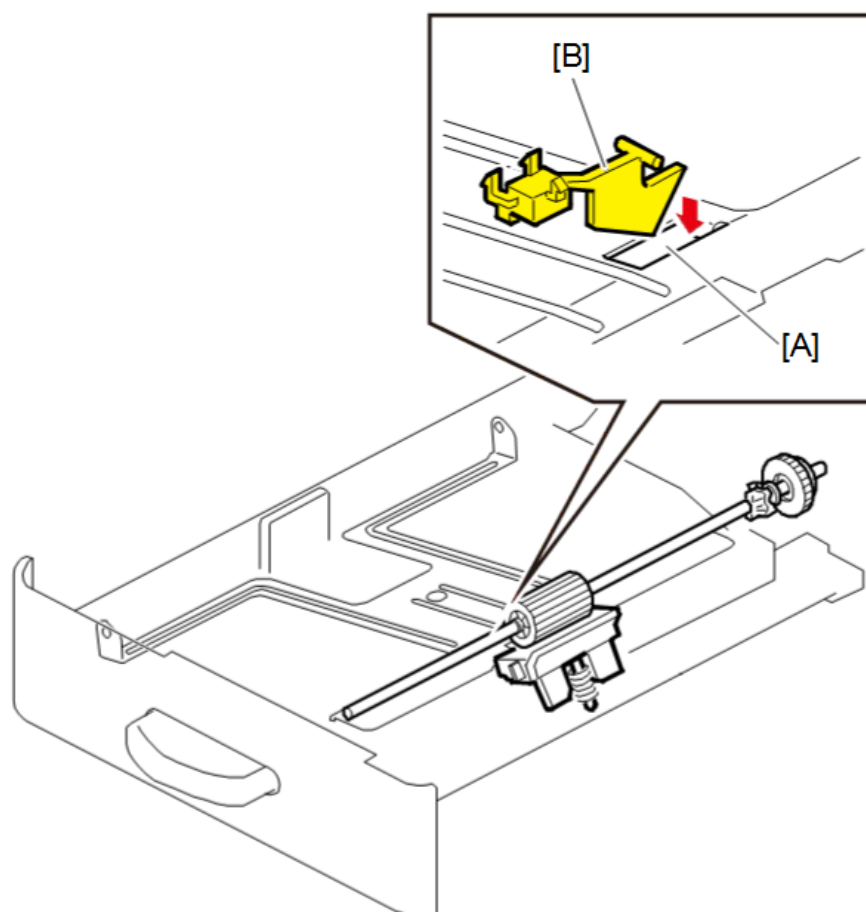

d205c9054

When the tray is being put in the machine, the sensor returns a paper present signal. This is because the feeler is up, even if the tray is empty (because it is raised by the bottom plate). So, if the sensor state changes to 'detects paper', the machine waits 3 seconds before reporting that paper is present.

### 6.10.3 BYPASS TRAY

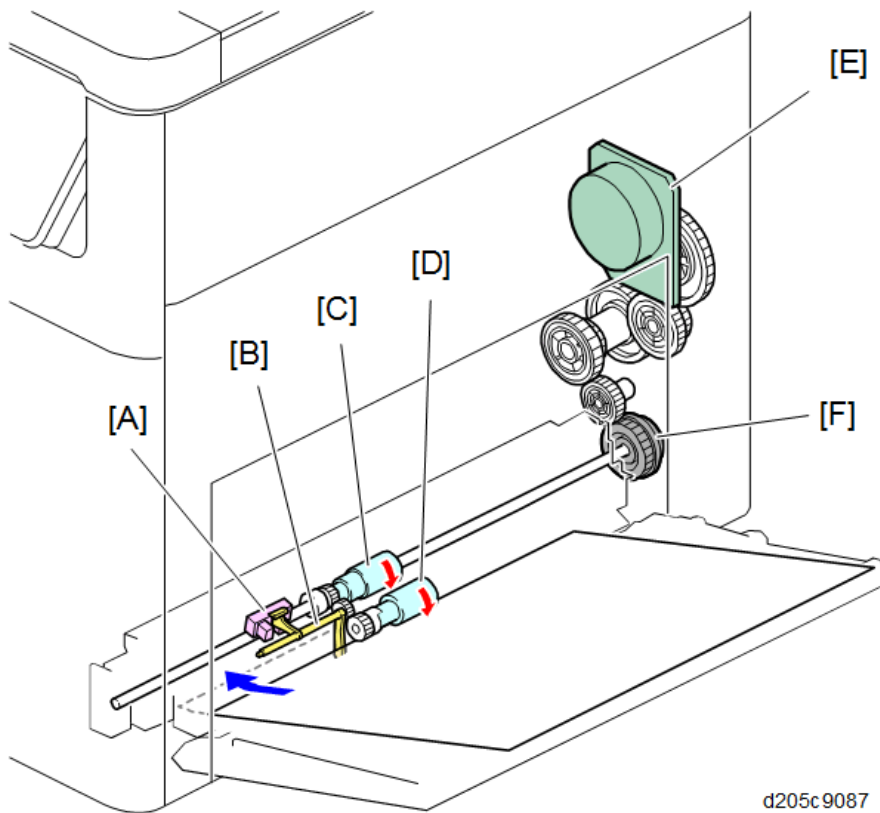

No.	Name	No.	Name
A	Bypass paper end sensor	D	Bypass paper pick-up roller
B	Feeler	E	Main motor
C	Bypass paper feed roller	F	Bypass paper feed clutch

The bypass tray uses a friction pad system.

When you select the bypass tray and press the Start key, the bypass paper feed clutch [F] turns ON and the drive from the main motor [E] is transferred to the bypass paper pick-up roller [D].

Then the bypass paper pick-up roller is lowered and the paper is sent to the bypass paper feed roller [C]. The bypass paper feed roller feeds the paper into the mainframe.

Paper on the bypass tray is detected by the feeler [B] and the bypass paper end sensor [A].

### ***Bypass Tray Paper Registration***

The drive from the main motor [A] is transmitted to the registration roller through the registration clutch gear [B].

The registration sensor [C] is used for correcting paper skew and for detecting paper misfeeds.

A cleaning sheet is in contact with the registration roller. It removes dust from the registration roller to prevent it from entering the development unit.

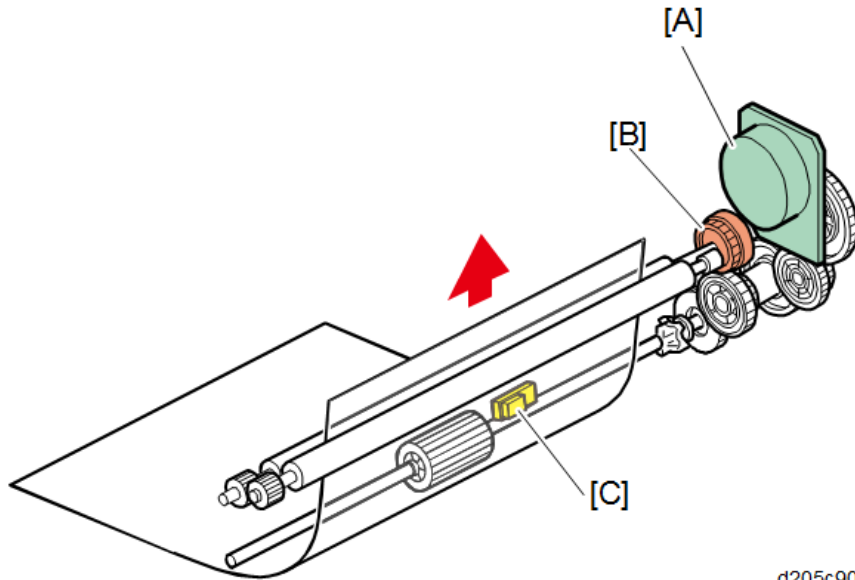

d205c9061

## 6.10.4 DUPLEX

### Overview

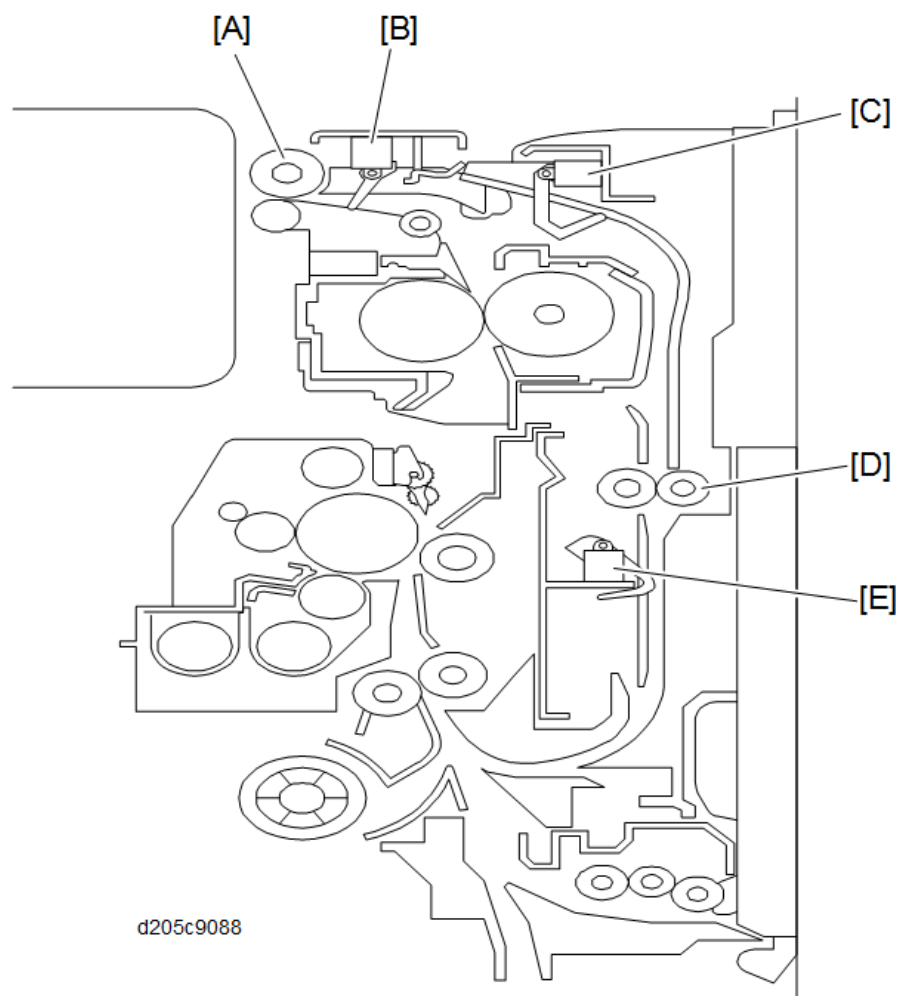

No.	Name	No.	Name
A	Paper exit/reverse roller	D	Duplex transport roller
B	Paper exit sensor	E	Duplex Exit Sensor
C	Duplex Entrance Sensor		

The printed sheet of paper from the fusing unit goes to the exit tray.

If the user selects the duplex mode, the paper exit/reverse roller [A] rotates in reverse.

Also, the duplex reverse clutch turns ON and the duplex transport roller [D] rotates.

The junction gate switches and the printed sheet of paper is transported to the duplex unit.

### Interleaving

#### Single-sided

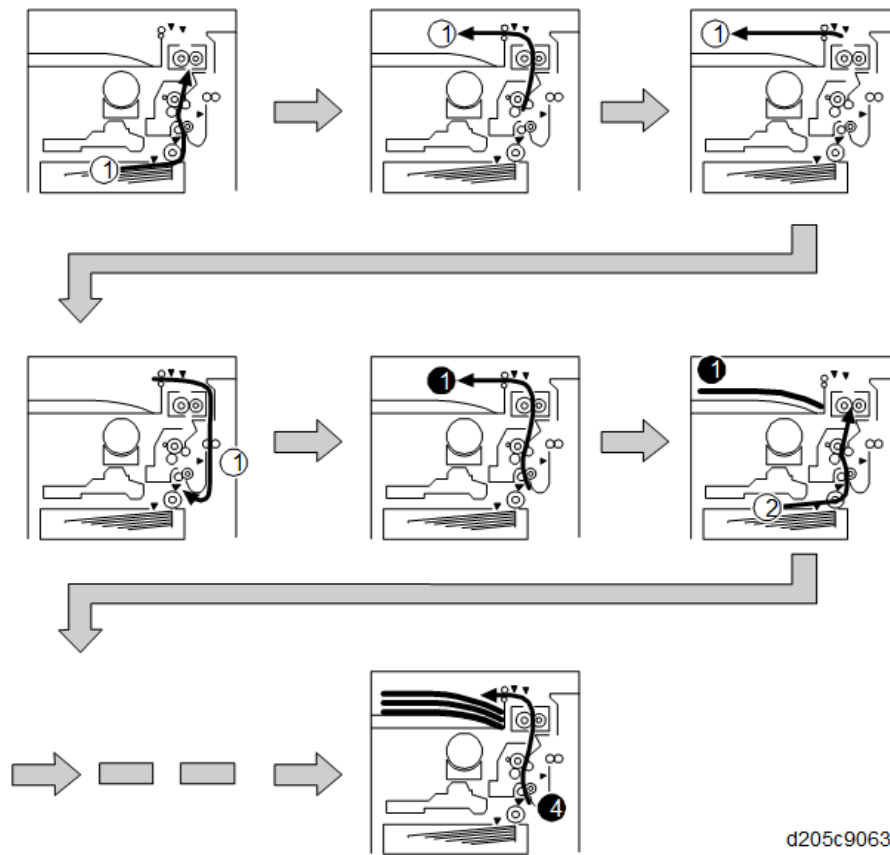

d205c9063

Detailed  
Descriptions

# Paper Feed

## Duplex

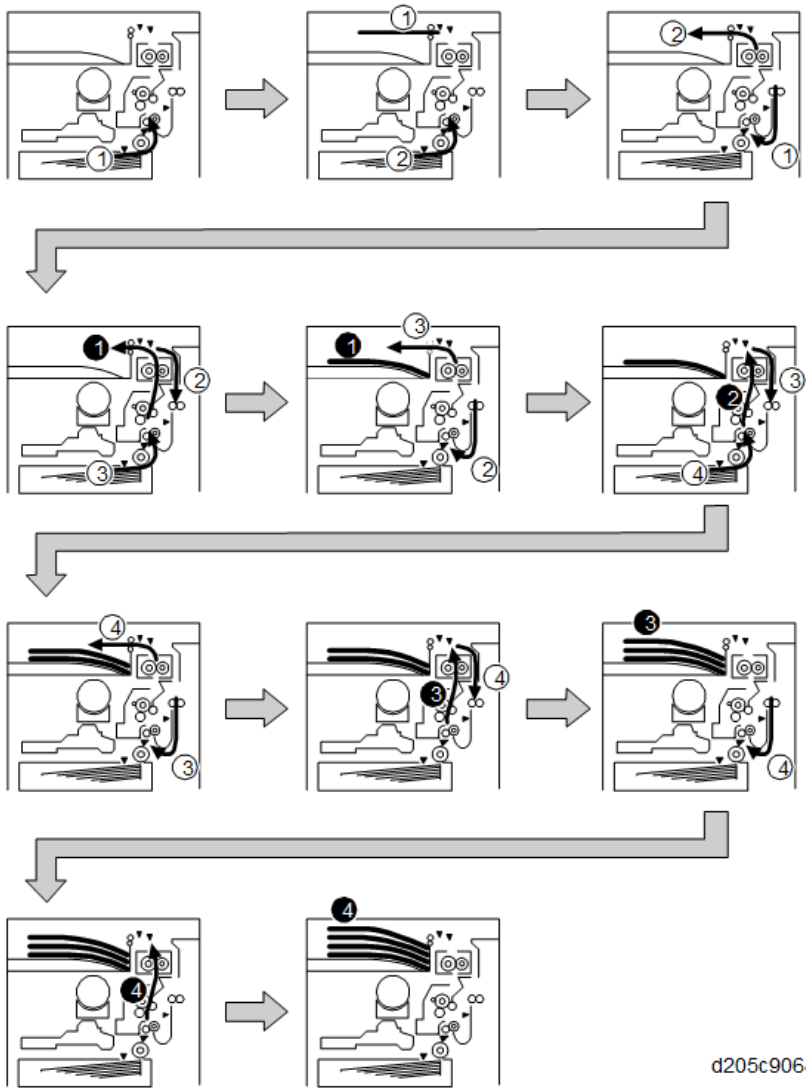

d205c9064

## 6.11 VENTILATION

### 6.11.1 OVERVIEW

To reduce the noise from the machine, the rotating speed of the intake/exhaust fans are adjusted depending on the following three conditions:

	Sleep mode, or ENG/CTL Off (Operation panel off)	Standby (Operation panel on)	Printing
Exhaust fan	OFF	ON Temperature/Humidity Sensor controls	ON Internal Temperature Sensor controls
Intake fan	OFF	ON Always half speed	ON Internal Temperature Sensor controls

#### Exhaust Fan Control in Standby

Temp. (°C)	~23	23 ~ 25	25 ~ 27	27 ~ 29	29 ~ 31	31 ~ 33	33 ~ 35	35 ~ 37	37 ~ 39	39~
Exhaust Fan	30%	30%	30%	35%	40%	45%	50%	60%	70%	80%

#### Exhaust Fan Control in Printing

Temp. (°C)	~36.5	36.5 ~ 37.0	37.0 ~ 38.0	38.0 ~ 39.0	39.0~
Exhaust Fan	40%	55%	70%	85%	100%

#### Intake Fan Control in Printing

Temp. (°C)	~39.0	39.0~
Intake Fan	Half Speed	Full speed



***Exhaust***

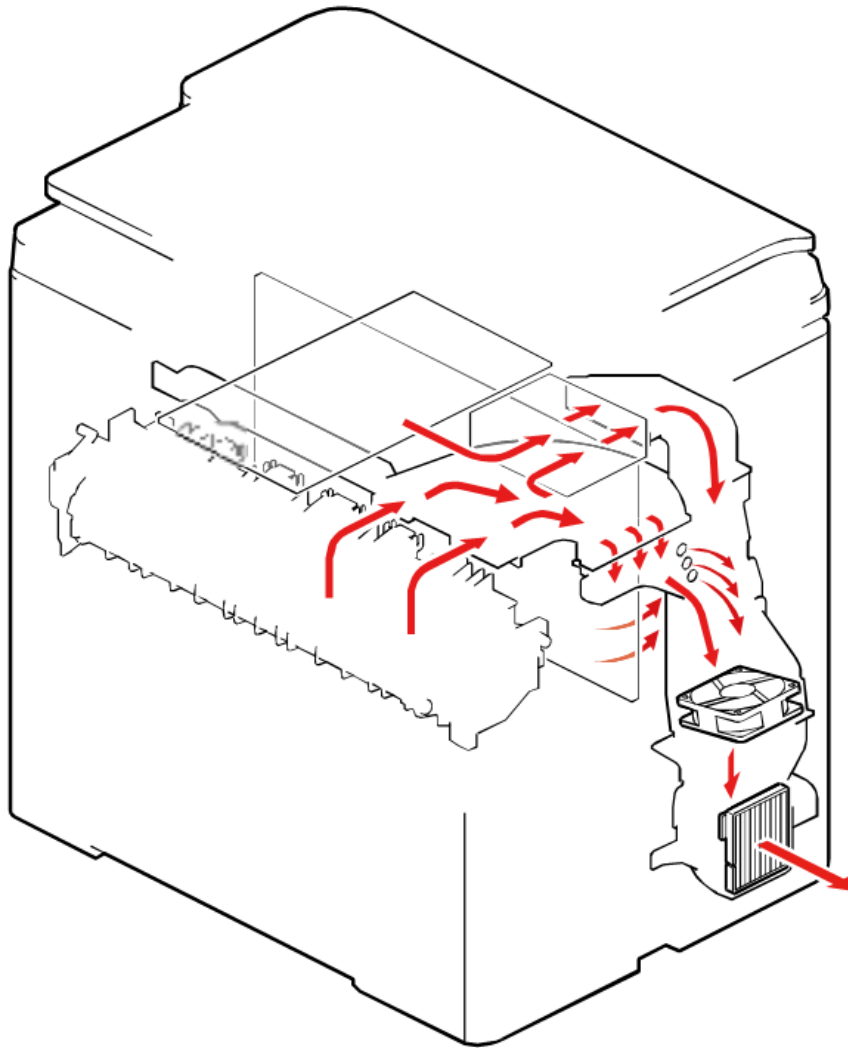

d205c9085

Heat in the controller box and on the PSU come to the main duct at the rear of the machine.

Heat in the fusing unit comes to the main duct through the fusing duct.

The exhaust fan ventilates the heat collected in the main duct.

The rear cover has an exhaust louver.

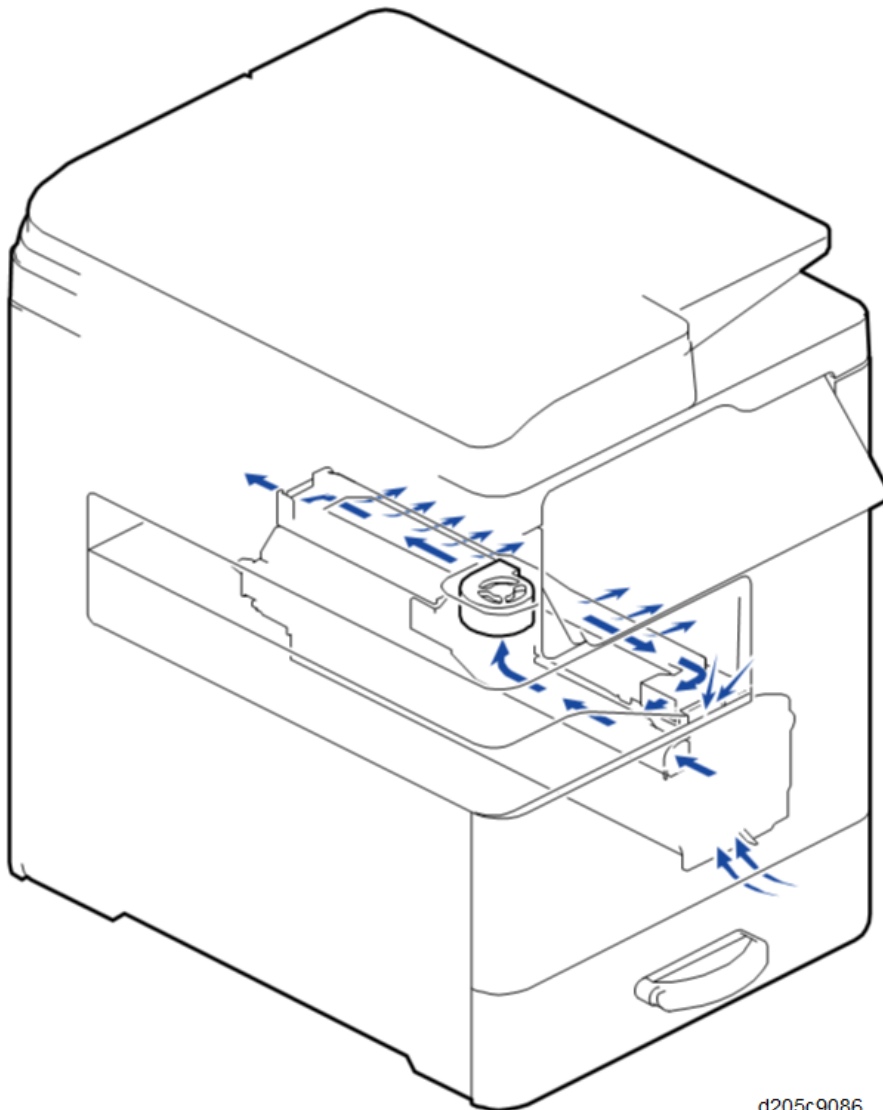
**Intake**

The external air enters into the intake located in front of the PCDU through gaps in the handle of the front cover, or the gaps in the tray's cover. The fresh air comes through the duct, and is collected by the intake fan.

The intake fan cools down the PCDU by ventilating the top side of the PCDU directly.

To prevent the temperature rise caused by heat leaked from the fusing unit, there is an insulating layer between the fusing unit and the PCDU.

## **6.12 OPERATION PANEL**

Refer to "Smart Operation Panel" manual for details.

## 6.13 ELECTRICAL PARTS

### 6.13.1 BLOCK DIAGRAM

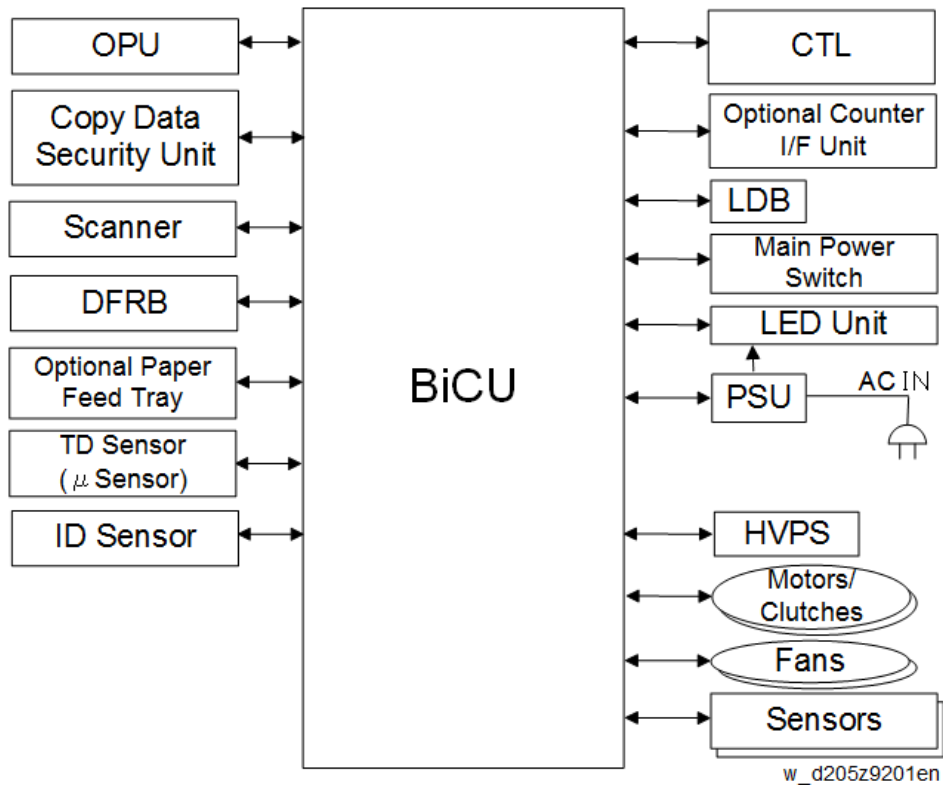

Detailed Descriptions

## 6.13.2 BOARD OUTLINE

### **Controller**

Controls the MFP system overall. Contains an MIPS CPU, controller ASIC, IO control ASIC, and RAM.

### **LDB**

LD control circuit which drives the laser diode with a universal driver.

### **BiCU (Base-Engine Image Control Unit)**

Controls the engine, as well as MFP engine sensors, motors and solenoids (The BiCU has the IOB functions).

### **FCU (Fax Controller Unit)**

Controls the fax program.

### **OPU (Operation Panel Unit)**

Controls the operation panel.

### **HVPS (High Voltage Power Supply)**

Generates high-voltage power required for process control. The power pack consists of two units: T1T2 for transfer and CB for charging/developing.

### **PSU (Power Supply Unit)**

Generates DC power from the mains AC power supply, and supplies it to each control circuit. Contains an AC drive circuit for controlling the fusing lamp.

### **DFRB (Document Feeder Relay Board)**

Controls motors, sensors, and solenoids in the ARDF.

### **Fuse**

Refer to Fuse Location. (page 5-124)

## 6.14 OTHER FEATURES

### 6.14.1 SILENT MECHANISM

The following features help the machine run as silently as possible.

#### **New lubricant to reduce noise when driving the main unit**

Grease with a high silencing effect (G-1077) is applied to the drive components. When replacing one of these components, apply this grease as stated in the replacement procedures.

#### **Features of G-1077**

- Low coefficient of friction
- Very stable, thanks to low oil separation

#### **Labyrinth Configuration of the Exterior**

Sound insulation properties are improved by the concavo-convex shape of the contact surfaces of the exterior covers.

This may make some covers hard to remove. Be careful when removing covers.

#### **Helmholtz Resonators in the Main Unit**

Blowing into an empty bottle may make a sound under some conditions, due to resonance inside the bottle.

Some parts of the internal molds adopt a Helmholtz resonator for friction loss of resonance generated by some specific frequencies.

#### **Silent Mode**

Silent mode decreases the noise level by increasing the interval between sheets; slower printing. This prevents the internal temperature from increasing, allowing a lower fan operation level: The silent mode can be selected through the user tools.

	Scanning speed	CPM	Fusing Temp.	Noise Level
Standard mode	136 mm/s	30 CPM	145 °C	59 dB
Silent mode	100 mm/s	15 CPM	140 °C	Less than 55 dB

## 6.14.2 TRANSITION FOR POWER SAVING

Power-saving status and transition conditions are as shown below.

### Outline of Power-Saving Transition (1/2)

Power-Saving Status	Power Save LED	Control Panel	Printer	Scanner	HDD	Controller
	Status description and status transition conditions					
[1] Standby	ON	LCD ON	ON (standby)	ON (standby)	ON	ON
	Printable <b>Status transition conditions</b> <ul style="list-style-type: none"> <li>▪ Power Save key ON: to [2] or [3]</li> <li>▪ Timer: to [4] or [5]</li> <li>▪ Light detection in darkness: to [5]</li> </ul>					
[2] Printing in silence/power saving	ON	LCD OFF/ ON	ON (standby)	ON (silence)	ON	ON
	<b>Status transition conditions</b> <ul style="list-style-type: none"> <li>▪ Power Save key ON: to [1]</li> <li>▪ Internal timer: to [3] or [5]</li> <li>▪ Automatic transition:* to [5]</li> </ul> *when the condition before transition to [2] is [1], [5], or [6]					
[3] Lower power status	ON	LCD OFF/ ON	ON (lower power)	ON (silence)	ON	ON
	Fusing temperature is lowered. <b>Status transition conditions</b> <ul style="list-style-type: none"> <li>▪ Key operation or release request (LCD lights): to [1]</li> <li>▪ Release request (printing): to [2]</li> <li>▪ Timer: to [5]</li> </ul>					
[4] Standby, fusing	ON	LCD ON	ON (silence)	ON (silence)	ON	ON

Power-Saving Status	Power Save LED	Control Panel	Printer	Scanner	HDD	Controller
	Status description and status transition conditions					
OFF status	Fusing OFF. The screen is lit. (Functions that do not use the print engine are usable.) <b>Status transition conditions</b> <ul style="list-style-type: none"> <li>▪ Key operation, displayed software change, release request (LDC ON): to [1]</li> <li>▪ Timer, Power Save key pressed, light detection in darkness: to [5]</li> </ul>					

### Outline of Transition for Power Saving (2/2)

Power Saving Status	Power Save LED	Control Panel	Printer	Scanner	HDD	Controller
	Status description and status transition conditions					
[5] Silent status	ON	LCD OFF/ ON	ON (silence)	ON (silence)	ON	ON
	Fusing OFF, HDD accessible, SD accessible. Peripherals start in silence. Tentative power-saving status for transition to Sleep mode (engine OFF, STR). <b>Status transition conditions</b> <ul style="list-style-type: none"> <li>▪ Power Save key ON or release request (LCD lights): to [1]</li> <li>▪ Release request (printing): to [2]</li> <li>▪ Power Save key pressed, ARDF open/close or original setting, or light detection in brightness: to [4]</li> <li>▪ Timer: to [6]</li> </ul>					
[6] Engine OFF status	Fade IN/OUT +ON	LCD Sleep/OFF/ON	OFF	OFF	OFF/ON	ON



Power Saving Status	Power Save LED	Control Panel	Printer	Scanner	HDD	Controller
	Status description and status transition conditions					
(Sleep mode)	Status to control engine OFF (power for control panel, HDD, and engine OFF) <b>Status transition conditions</b> <ul style="list-style-type: none"> <li>▪ Power Save key ON or release request: to [1]</li> <li>▪ Engine of the connected submachine OFF and print command from the mainmachine: to [2]</li> <li>▪ Release request (HDD access): to [5]</li> <li>▪ Timer: to [7]</li> </ul>					
[7] STR (Sleep mode)	Fade IN/OUT	LCD Sleep/OFF/ON	OFF	OFF	OFF	STR
	Controller main CPU OFF but power of the sub-CPU ON. <b>Status transition conditions</b> <ul style="list-style-type: none"> <li>▪ Release request: [6] *Recovery request from the subsystem</li> </ul>					
[8] Main power OFF	OFF	Power OFF/LCD Sleep	OFF	OFF	OFF	OFF
	- <b>Status transition conditions</b> <ul style="list-style-type: none"> <li>▪ Main power key ON: to [1] or [4]</li> </ul>					

Conditions for no transition to the Power Save mode

- In SP mode
- In UP mode (excluding the transition from standby to fusing standby OFF)
- During updating
- During rebooting

### 6.14.3 DUTY CONTROL

Duty control is a mechanism that prevents overheating, melting and aggregating toner due to internal temperature rise by forcibly stopping an imaging/printing job more often.

The internal temperature sensor measures the temperature of the development drive shaft.

If the internal temperature reaches the activating temperature of STEP1 through STEP3, duty control is activated in accordance with the conditions for each step, to avoid overheating of the parts for imaging.

Upon starting printing in each step, the message "The printing speed is now being limited" is displayed through a banner or pop-up screen, to indicate that duty control is activated.

When the internal temperature becomes higher than the STEP1/STEP2 Activating Temperature, the machine stops the printing job for 30 seconds every after printing four sheets, and the banner "The printing speed is now being limited" is displayed.

When the internal temperature becomes higher than the STEP3 Activating Temperature, the machine stops the printing job and the pop-up screen "The printing speed is now being limited" is displayed.

When the internal temperature becomes lower than the STEP1/STEP2 Deactivating Temperature, duty control is deactivated, the banner disappears, and the machine runs in normal state.

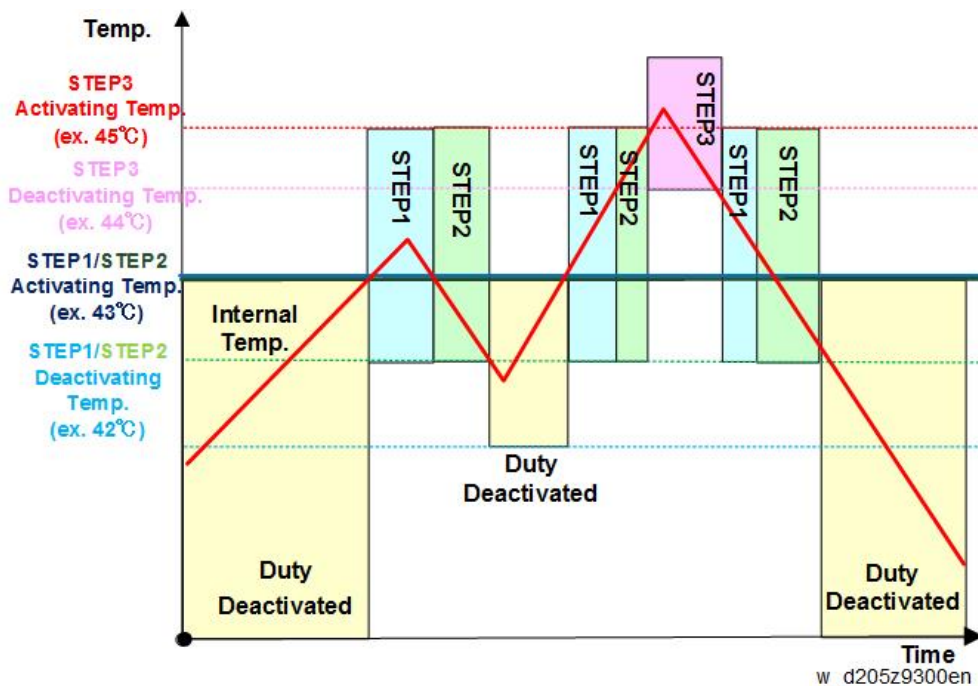

## Other Features

Status	Standard (Duty Deactivated)	STEP1/2 (Duty Activated)	STEP3 (Duty Activated)
Internal Temperature	42°C or lower	43°C or higher	45°C or higher
Line speed	136 mm/s		Standby (stop)
Operation panel screen	No	Banner	Pop-up
Printing	Normal (30CPM)	Stops for 30 seconds every 4 sheets	Stops

## High Productivity Mode

There are operation modes that keep high productivity without entering under the Duty control. Executing these SPs allows you to configure the best setting for your customer:

	Mode	Standard Mode	High Productivity Mode A	High Productivity Mode B	High Productivity Mode C
	SP	SP1-960-001	SP1-960-002	SP1-960-003	SP1-960-004
Fan (Start Temp)		[A]			[B]
Fusing Temp in Standby		[C]	[D]	[E]	
FCOT		[F]	[G]	[H]	
Fan Rotating Speed in Standby		[I]			[J]

### Mode Description

	Description
[A]	Rotates at full speed when the internal temperature is 44°C or higher.
[B]	Rotates at full speed when the internal temperature is 42°C or higher.
[C]	Lowers the fusing temperature from 145°C to 110°C when the internal temperature is 42°C or higher.
[D]	Lowers the fusing temperature from 145°C to 110°C when the internal temperature is 40°C or higher.
[E]	Lowers the fusing temperature from 145°C to 75°C when the internal temperature is 37°C or higher.
	Lowers the fusing temperature from 145°C to 75°C when the internal temperature is 37°C or higher.
[F]	Increases FCOT 3 sec (from 5 sec to 8 sec) when the internal temperature is 42°C.
[G]	Increases FCOT 3 sec (from 5 sec to 8 sec) when the internal temperature is 40°C.

Other Features

	Description
[H]	Increases FCOT 3 sec (from 5 sec to 12 sec) when the internal temperature is 37°C.
	Increases FCOT 3 sec (from 5 sec to 12 sec) when the internal temperature is 37°C.
[I]	Refer to page 6-67.
[J]	Refer to the table below.

**Fan Control in High Productivity Mode C: Standby**

Temp. (°C)	~23	23 ~ 25	25 ~ 27	27 ~ 29	29 ~ 31	31 ~ 33	33 ~ 35	35 ~ 37	37 ~ 39	39~
Exhaust Fan	30%	35%	40%	45%	50%	60%	70%	80%	80%	80%

## 6.14.4 OPERATION IN LOW-VOLTAGE MODE

The 200-V machine has a problem caused by low voltage upon start-up or printing.

To solve this problem, the 200-V machines have a "Low-Voltage mode".

	Low-Voltage mode	Standard-Voltage mode	Note
Voltage range	150 V – 187 V	187 V –	181.5 ±5.5 V (guaranteed operating range)
Process speed	100 mm/s	Silent mode speed: 100 mm/s Standard mode speed: 136 mm/s	
Productivity CPM	4.6 (30% of silent mode speed)	Silent speed: 15.5 Standard speed: 31.0	
Preprinting	Prerotation*1	No prerotation	Waiting for the temperature of the hot roller to rise

### Note

- \*1: The hot roller rotates for 2 to 5 seconds until the roller temperature reaches the specified value.

### Starting

Purpose: To decrease SC caused by low voltage

1. If SC542 (temperature gradient) is detected, the machine checks if the voltage is 187 V or lower (low voltage).

If low voltage is detected, the machine retries (the fusing lamp is set to OFF then ON again).

2. If the machine does not start after 3 retries mentioned above, "SC542-04" is displayed on the panel.

The customer turns OFF then ON the main power to restart.

3. For safety purposes, the fusing lamp is not turned ON if the temperature detected at the fusing thermistor (End) is higher than 200°C.

### Printing

Purpose: Securing fusing

The voltage upon starting printing is detected, and printing is performed in Low Voltage mode, if the detected voltage is low (less than 187 V).

**D259**  
**SERVICE MANUAL APPENDICES**





# D259 APPENDICES

## TABLE OF CONTENTS

<b>1. SPECIFICATIONS</b> .....	<b>1-1</b>
1.1 SPECIFICATIONS .....	1-1
1.1.1 MAINFRAME .....	1-1
1.2 SUPPORTED PAPER SIZES .....	1-4
1.2.1 PAPER FEED .....	1-4
1.2.2 PAPER EXIT .....	1-7
1.3 SOFTWARE ACCESSORIES .....	1-9
1.3.1 PRINTER DRIVERS .....	1-9
1.3.2 SCANNER AND LAN FAX DRIVERS .....	1-12
1.4 OPTIONAL EQUIPMENT .....	1-13
1.4.1 PAPER FEED UNIT PB1090 .....	1-13
<b>2. PREVENTIVE MAINTENANCE TABLES</b> .....	<b>2-1</b>
2.1 MAINTENANCE TABLES .....	2-1
2.1.1 PREVENTIVE MAINTENANCE ITEMS .....	2-1
<b>3. SP MODE TABLES</b> .....	<b>3-1</b>
3.1 SERVICE PROGRAM MODE .....	3-1
3.1.1 ENABLING AND DISABLING SERVICE PROGRAM MODE .....	3-1
Entering SP Mode .....	3-1
Exiting SP Mode .....	3-1
3.1.2 TYPES OF SP MODES .....	3-1
SP Mode Button Summary .....	3-2
Switching Between SP Mode and Copy Mode for Test Printing .....	3-3
Selecting the Program Number .....	3-3
Exiting Service Mode .....	3-3
Service Mode Lock/Unlock .....	3-4
3.1.3 REMARKS .....	3-4
Display on the Operation Panel Screen .....	3-4
Others .....	3-5
3.2 MAIN SP TABLES-1 .....	3-6
3.2.1 SP1-XXX (FEED) .....	3-6
3.3 MAIN SP TABLES-2 .....	3-16
3.3.1 SP2-XXX (DRUM) .....	3-16
3.4 MAIN SP TABLES-3 .....	3-23

3.4.1	SP3-XXX (PROCESS) .....	3-23
3.5	MAIN SP TABLES-4.....	3-24
3.5.1	SP4-XXX (SCANNER) .....	3-24
3.6	MAIN SP TABLES-5 (ENGINE) .....	3-30
3.6.1	SP5-XXX (MODE) .....	3-30
3.7	MAIN SP TABLES-5 (CONTROLLER) .....	3-36
3.7.1	SP5-XXX (MODE) .....	3-36
3.8	MAIN SP TABLES-6.....	3-76
3.8.1	SP6-XXX (PERIPHERALS).....	3-76
3.9	MAIN SP TABLES-7 (ENGINE) .....	3-78
3.9.1	SP7-XXX (DATA LOG) .....	3-78
3.10	MAIN SP TABLES-7 (CONTROLLER).....	3-84
3.10.1	SP7-XXX (DATA LOG) .....	3-84
3.11	MAIN SP TABLES-8.....	3-96
3.11.1	SP8-XXX (DATA LOG2) .....	3-96
3.12	PRINTER SERVICE MODE .....	3-159
3.12.1	PRINTER SERVICE MODE .....	3-159
3.13	SCANNER SERVICE MODE .....	3-173
3.13.1	SP1-XXX .....	3-173
3.13.2	SP2-XXX .....	3-174
3.14	INPUT AND OUTPUT CHECK.....	3-176
3.14.1	INPUT CHECK TABLE (SP5-803) .....	3-176
3.14.2	OUTPUT CHECK TABLE (SP5-804) .....	3-177

#### **4. DEVICE SOFTWARE CONFIGURATION..... 4-1**

4.1	PRINTING FEATURES.....	4-1
4.1.1	BEHAVIOR OF USB PRINTER DETECTION.....	4-1
4.2	SCANNING FEATURES .....	4-1
4.3	MANAGEMENT FEATURES .....	4-2
4.3.1	HOW TO DISABLE THE DOCUMENT SERVER FUNCTION.....	4-2
4.4	SECURITY FEATURES .....	4-3
4.4.1	HOW TO RESTRICT ACCESS TO THE WIM JOB MENU.....	4-3
4.4.2	HOW TO RESTRICT WEB IMAGE MONITOR ACCESS TO THE DOCUMENT SERVER.....	4-3
4.4.3	USER AUTHENTICATION FOR SPECIFIC MFP APPLICATIONS .....	4-5
4.5	CONNECTIVITY .....	4-5

# APPENDIX: SPECIFICATIONS

REVISION HISTORY		
Page	Date	Added/Updated/New
		None



# 1. SPECIFICATIONS

## 1.1 SPECIFICATIONS

### 1.1.1 MAINFRAME

Configuration:	Desktop	
Drum Type:	OPC Drum	
Scanning Element:	Line sequential scanning CIS	
Copy Process:	Laser beam scanning/marketing & electro-photographic printing	
Development:	Dry two-component magnetic brush development system	
Fusing:	Heating roller pressure system	
Resolution:	Scan: 600 dpi Print: 600 dpi	
Original Type:	Sheets, book, three-dimensional object	
Original Reference Position:	Platen: Left rear corner ARDF: Center	
Warm-up Time:	67 seconds or less (Cold start) 30 seconds or less (Quick start)	
Original Type:	Sheets, book, three-dimensional object	
Max Imageable Area:	Platen: 297 x 216 mm (11.7 x 8.5 in) ARDF: 297 x 1260 mm (11.7 x 49.6 in)	
Print Paper Size:	Standard Tray:	A4 to A6
	Bypass Tray:	A3 to A6, B4 to B6, Postcard

## Specifications

	Optional Tray:	W: 90 to 297 mm (3.5 to 11.7 in) L: 148 to 600 mm (5.8 to 23.6 in)
Printing Paper Weight:	Standard Tray:	60 to 105 g/m <sup>2</sup>
	Bypass Tray:	52 to 162 g/m <sup>2</sup>
Missing Image Area:		Leading Edge: 3 ± 2 Trailing Edge: 3 ± 2 (4.2 ± 2 mm Duplex) Left: 2 ± 1.5 mm Right: 2 + 2.5 / -1.5 mm
First Copy Time:		5 seconds or less (LT/A4 LEF, 1st tray)
Copy Speed (Simplex):		Standard mode:30 cpm Silent Mode: 15 cpm *Thick paper 7.5 cpm
Copy Speed (Duplex):		Standard: 20 cpm Silent Mode: 9 cpm
Reproduction Ratio:		Enlargement      400%, 200%, 141%, 122%, 115%
		Same size            100%
		Reduction            93%, 87%, 82%, 71%, 61%, 50%, 25%
Zoom:		25 to 400% (1% step)
Continuance Copy Amount:		1 to 99 sheets
Print Paper Capacity:	Standard Tray:	250 sheets x 1 (80 g/m <sup>2</sup> )
	Bypass Tray:	10 sheets
Image Density:		7 levels
Auto Clear Time:		60 seconds (default)
Automatic Shut-off:		1 minute (1 to 240 minutes)
Toner Replenishment:		Toner bottle
Optional Equipment:		Paper Feed Tray (1 Tray)
Toner Yield:		3000 sheets
Memory:		1024MB (Standard), 1536MB (Extended)

Power Source:	120 to 127 V, 60 Hz (for NA) 220 to 240 V, 50/60 Hz (for EU/AA) 110 V, 60 Hz (for TWN)
Power Consumption:	NA 1180 W EU 1140 W TW 1100 W CN 1140 W
Noise Emission: *in paper feeding	Standard Mode: 56.5 dB Silent Mode: 52.5 dB
Dimensions (W x D x H):	350 x 493 x 425 mm (13.8 x 19.4 x 16.7 in)
Weight:	32 kg (70.5 lb) or less
<b>Duplex</b>	
Print Paper Size:	A3/DLT to A5/HLT A5/HLT LEF is not supported. Duplex printing with A6 SEF, B6 SEF, or HLT LEF is not supported.

## 1.2 SUPPORTED PAPER SIZES

### 1.2.1 PAPER FEED

✓	Supported
-	Not Supported
1	Size up to DLT/A3 is guaranteed.

Size			Bypass	Main Paper Feed Tray	Optional Paper Feed Tray	Auto Detection
A3	SEF	297 x 420 mm	✓	-	-	1
A4	SEF	210 x 297 mm	✓	-	-	1
A4	LEF	297 x 210 mm	✓	✓	✓	1
A5	SEF	148 x 210 mm	✓	✓	✓	1
A5	LEF	210 x 148 mm	✓	✓	✓	-
A6	SEF	105 x 148 mm	✓	✓	-	-
B4	SEF	257 x 364 mm	✓	-	-	1
B5	SEF	182 x 257 mm	✓	-	-	1
B5	LEF	257 x 182 mm	✓	✓	✓	-



Size			Bypass	Main Paper Feed Tray	Optional Paper Feed Tray	Auto Detection
B6	SEF	128 x 182 mm	✓	✓	-	-
DLT	SEF	11 x 17 in.	✓	-	-	1
Legal	SEF	8.5 x 14 in.	✓	-	-	1
Foolscap	SEF	8.5 x 13 in.	-	-	-	1
Letter	SEF	8.5 x 11 in.	✓	-	-	1
Letter	LEF	11 x 8.5 in.	✓	✓	✓	1
GovernmentLG	SEF	8.25 x 14 in.	✓	-	-	1
Folio	SEF	8.25 x 13 in.	✓	-	-	1
F/GL	SEF	8 x 13 in.	✓	-	-	1
G LT	SEF	8 x 10.5 in.	✓	-	-	1
G LT	LEF	10.5 x 8 in.	✓	-	-	-
Eng Quatro	SEF	8 x 10 in.	✓	-	-	1
Eng Quatro	LEF	10 x 8 in.	✓	-	-	-
Executive	SEF	7.25 x 10.5 in.	✓	-	-	1
Executive	LEF	10.5 x 7.25 in.	✓	-	-	-
Half Letter	SEF	5.5 x 8.5 in.	✓	✓	✓	1
Com10	SEF	4.125 x 9.5 in.	✓	-	-	-
Monarch	SEF	3.875 x 7.5 in.	✓	-	-	-
C5	SEF	162 x 229 mm	✓	-	-	-

## Supported Paper Sizes

Size			Bypass	Main Paper Feed Tray	Optional Paper Feed Tray	Auto Detection
C5	LEF	229 x 162 mm	✓	-	-	-
C6	SEF	114 x 162 mm	✓	-	-	-
DL Env	SEF	110 x 220 mm	✓	-	-	-
8K	SEF	267 x 390 mm	✓			
16K	SEF	195 x 267 mm	✓			
16K	LEF	267 x 195 mm	✓	✓	✓	
11x15	SEF	11 x 15 in.	✓	-	-	1
11x14	SEF	11 x 14 in.	✓	-	-	1
10x15	SEF	10 x 15 in.	✓	-	-	1
10x14	SEF	10 x 14 in.	✓	-	-	1
Oficio	SEF	8.5 x 13.4 in.	✓	-	-	1

## 1.2.2 PAPER EXIT

✓	Supported
-	Not Supported

Size			Main Paper Feed Tray
A3	SEF	297 x 420 mm	✓
A4	SEF	210 x 297 mm	✓
A4	LEF	297 x 210 mm	✓
A5	SEF	148 x 210 mm	✓
A5	LEF	210 x 148 mm	✓
A6	SEF	105 x 148 mm	✓
B4	SEF	257 x 364 mm	✓
B5	SEF	182 x 257 mm	✓
B5	LEF	257 x 182 mm	✓
B6	SEF	128 x 182 mm	✓
DLT	SEF	11 x 17 in.	✓
Legal	SEF	8.5 x 14 in.	✓
Foolscap	SEF	8.5 x 13 in.	✓
Letter	SEF	8.5 x 11 in.	✓
Letter	LEF	11 x 8.5 in.	✓
GovernmentLG	SEF	8.25 x 14 in.	✓
Folio	SEF	8.25 x 13 in.	✓
F/GL	SEF	8 x 13 in.	✓
G LT	SEF	8 x 10.5 in.	✓

## Supported Paper Sizes

Size			Main Paper Feed Tray
G LT	LEF	10.5 x 8 in.	✓
Eng Quatro	SEF	8 x 10 in.	✓
Eng Quatro	LEF	10 x 8 in.	✓
Executive	SEF	7.25 x 10.5 in.	✓
Executive	LEF	10.5 x 7.25 in.	✓
Half Letter	SEF	5.5 x 8.5 in.	✓
Com10	SEF	4.125 x 9.5 in.	✓
Monarch	SEF	3.875 x 7.5 in.	✓
C5	SEF	162 x 229 mm	✓
C5	LEF	229 x 162 mm	✓
C6	SEF	114 x 162 mm	✓
DL Env	SEF	110 x 220 mm	✓
16K	SEF	195 x 267 mm	✓
11x15	SEF	11 x 15 in.	✓
11x14	SEF	11 x 14 in.	✓
10x15	SEF	10 x 15 in.	✓
10x14	SEF	10 x 14 in.	✓
Oficio	SEF	8.5 x 13.4 in.	✓

## 1.3 SOFTWARE ACCESSORIES

The printer drivers and utility software are provided on one CD-ROM. An auto-run installer allows you to select which components to install.

### 1.3.1 PRINTER DRIVERS

✓: Supported

-: Not supported

#### Windows

OS	Type	PCL5c	PCL6	PS3	XPS
Windows Vista	Starter	-	-	-	-
	Home Basic	✓	✓*3	✓*3	✓*1
	Home Premium	✓	✓*3	✓*3	✓*1
	Business	✓	✓*3	✓*3	✓*1
	Ultimate	✓	✓*3	✓*3	✓*1
	Enterprise	✓	✓*3	✓*3	✓*1
Windows 7	Starter	-	-	-	-
	Home Basic	-	-	-	-
	Home Premium	✓	✓	✓	✓
	Professional	✓	✓	✓	✓
	Ultimate	✓	✓	✓	✓
	Enterprise	✓	✓	✓	✓
Windows 8/8.1	Windows 8	✓	✓	✓	✓
	Pro	✓	✓	✓	✓
	Enterprise	✓	✓	✓	✓
	RT	-	-	-	-
Windows Server	Standard Edition	✓*2	✓*2	✓*2	-

Software Accessories

OS	Type	PCL5c	PCL6	PS3	XPS
2003/ R2	Enterprise Edition	√*2	√*2	√*2	-
	Datacenter Edition	-	-	-	-
	Web Edition	-	-	-	-
Windows Server 2008/R2	Standard Edition	√	√	√	√
	Enterprise Edition	√	√	√	√
	Standard without Hyper-V	√	√	√	√
	Enterprise without Hyper-V	√	√	√	√
	Datacenter Edition	-	-	-	-
	Web Edition	-	-	-	-
Windows Server 2012/R2	Foundation	√	√	√	√
	Essentials	√	√	√	√
	Standard	√	√	√	√
	Datacenter	-	-	-	-

\*RPCS driver has been discontinued.

\*1:SP1 or later is recommended

\*2:SP2 or later is Recommended

\*3:SP1 or later is recommended

**Mac OS Environment**

OS	PS3	Printer Utility for Mac
Mac OS 8.6 or later, Mac OS X classic	-	-
Mac OS X Native: v.10.57 or later	√	-

**UNIX Environment**

UNIX Platforms	Version
Sun Solaris	9, 10
HP-UX	11.x, 11i v2, 11i v3
Red Hat Linux	Enterprise V4, V5, V6
SCO OpenServer	5.0.7, 6.0
IBM AIX	V 5L, V5.3, V6.1, V7.1

**SAP R/3 Environment (Device Type / Barcode & OCR Package)**

Device Type will be provided from SAP itself in SAP Printer Vendor Program.

For the detailed specification, please refer to another announcement to be issued in the future.

Supported Barcode & OCR Fonts	Barcode Fonts	Code 128, Code 39, Code 93, Codabar, 2 of 5 interleaved/Industrial/Matrix, MSI, USPS, UPC/EAN
	OCR Fonts	OCR A, OCR B

**Note**

- The PS3 drivers are all genuine AdobePS drivers, except for Windows 2000, which uses Microsoft PS.
- A PPD file for each operating system is provided with the driver.

## 1.3.2 SCANNER AND LAN FAX DRIVERS

### Operating system for TWAIN driver:

Windows Vista/7/8/8.1, Windows Server 2003/2003 R2/2008/2008 R2/2012/2012 R2  
(TWAIN scanner runs in 32-bit compatible mode on a 64-bit operating system, so TWAIN scanner is not compatible with 64-bit applications. Use it with 32-bit applications.)

### Operating system for WIA driver:

Windows Vista (SP1 or later)/7/8/8.1, Windows Server 2008/2008 R2/2012/2012 R2  
(WIA scanner can function under both 32- and 64-bit operating systems.)

### Operating system for LAN FAX driver:

Windows Vista, Windows 7, 8, 8.1, Windows Server 2003, Windows Server 2008, Windows Server 2012, Windows Server 2008 R2, Windows Server 2012 R2

#### Note

- The LAN Fax driver lets you fax documents directly from your PC. Address Book Editor and Cover Sheet Editor are to be installed as well.
- The Network TWAIN driver operates in 32-bit compatibility mode on 64-bit operating systems
- The Network TWAIN driver is provided on the scanner drivers CD-ROM.



## 1.4 OPTIONAL EQUIPMENT

### 1.4.1 PAPER FEED UNIT PB1090

Items	Specification
Paper Feed System	RF System
Configuration	Front loading paper feed tray
Tray Capacity	500 sheets
Paper Size	A5/HLT SEF to A4/LT LEF
Paper Weight	60 - 162 g/m <sup>2</sup>
Power Source	DC 24 V, 5 V (from the main frame)
Power Consumption	Less than 15 W
Dimensions	W:350 × D:460 × H:140 mm (13.8 × 18.1 × 5.5 in)
Weight	6.0 kg (13.2 lb) or less



**APPENDIX:**

**PREVENTIVE MAINTENANCE TABLES**

<b>REVISION HISTORY</b>		
<b>Page</b>	<b>Date</b>	<b>Added/Updated/New</b>
		None



## 2. PREVENTIVE MAINTENANCE TABLES

### 2.1 MAINTENANCE TABLES

#### 2.1.1 PREVENTIVE MAINTENANCE ITEMS

Chart: A4 (LT)/5%

Mode: 2 prints/job

Color Ratio: 30%

Environment: Normal temperature and humidity

Yield may change depending on circumstances and print conditions.

Symbol keys: C: Clean, R: Replace, L: Lubricant, I: Inspect

#### ↓ Note

- **Yield Parts:**

The parts mentioned in these tables have a target yield. However, the total copy/print volume made by the machine will not reach the target yield within the machine's targeted lifetime if the machine is used under the target usage conditions (ACV, color ratio, and P/J). So, these parts are categorized not as PM parts but as yield parts (EM parts). The parts with "(R)" in this table are yield parts.

The PM count for the following items is based on the sheets of copy paper:

Item	60K	120K	180K	EM	Remarks
<b>Laser Optics</b>					
Exposure Glass		C//L		C//L	Ricoh exposure glass cleaner
ADF Exposure Glass		C//L		C//L	Ricoh exposure glass cleaner
APS Sensor		C//L		C//L	Dry cloth
Dust Shield Glass		C//L		C//L	Dry cloth
<b>PCDU</b>					
PCDU	R				

Maintenance Tables

Item	60K	120K	180K	EM	Remarks
<b>Transfer</b>					
Transfer Roller (Quenching Lamp)		R			
ID Sensor	C//L			C//L	Wipe with a damp cloth.
PCL Cover	C//L			C//L	Wipe with a damp cloth.
<b>Fusing Unit</b>					
Hot Roller		R			
Pressure Roller		R			
Hot Roller Stripper Pawls		R			
Hot Roller Bearing				R	
Pressure Roller Bearing				R	
<b>Paper Transport (Mainframe)</b>					
Registration Roller	C//L			C//L	Wipe with a damp cloth.
Registration Sensor				C//L	Remove paper dusts with blower brush
Paper Dust Collector				C//L	Remove paper dusts with blower brush
Paper Feed Roller		R		C//L	Wipe with a damp cloth.
Bypass Pick-up Roller				C//L	Wipe with a damp cloth.
Bypass Feed Roller				C//L	Wipe with a damp cloth.
Friction Roller		R		C//L	Wipe with a damp cloth.
<b>Paper Transport (Option)</b>					
Pick-up Roller				C//L	Wipe with a damp cloth.
Paper Feed Roller		R		C//L	Remove paper dusts with blower brush

Item	60K	120K	180K	EM	Remarks
Friction Roller		R		C//L	Remove paper dusts with blower brush
Vertical Transport Roller		R		C//L	Wipe with a damp cloth.
Tray Bottom Plate Pad				C//L	Wipe with a damp cloth.
Paper Feed Sensor				C//L	Remove paper dusts with blower brush
<b>Duplex</b>					
Duplex Roller				C//L	Wipe with a damp cloth.
<b>Paper Exit</b>					
Paper Exit Reverse Roller				C//L	Wipe with a damp cloth.
<b>Others</b>					
Exhaust Filter				R	

The PM count for the following items is based on the number of originals fed:

Maintenance Tables

Item	30K	45K	EM	Remarks
<b>ARDF</b>				
Platen Cover		C/I/L		Wipe with an alcohol- or water-dampened cloth.
White Guide Plate		C/I/L		
ARDF Original Set Sensor		C/I/L		Wipe with a dry cloth, and remove paper dusts with blower brush
ARDF Feed Cover Sensor		C/I/L		
ARDF Registration Sensor		C/I/L		
ARDF Pick-up Roller		C/I/L		Wipe with an alcohol- or water-dampened cloth.
ARDF Feed Roller		C/I/L		
ARDF Pullout Roller		C/I/L		
ARDF Transport Roller		C/I/L		
ARDF Paper Exit Roller		C/I/L		
ARDF Inverter Drive Roller		C/I/L		
ARDF Inverter Driven Roller		C/I/L		
ARDF Friction Pad	C/I/L			



# APPENDIX:

## SP MODE TABLES

REVISION HISTORY		
Page	Date	Added/Updated/New
		None



---

## 3. SP MODE TABLES

### 3.1 SERVICE PROGRAM MODE

#### CAUTION

- Make sure that the data-in LED (↻) is not on before you go into the SP mode. This LED indicates that some data is coming to the machine. When the LED is on, wait for the copier to process the data.

#### 3.1.1 ENABLING AND DISABLING SERVICE PROGRAM MODE

##### Note

- The Service Program Mode is for use by service representatives only. If this mode is used by anyone other than service representatives for any reason, data might be deleted or settings might be changed. In such case, product quality cannot be guaranteed any more.

#### *Entering SP Mode*

For details, ask your supervisor.

#### *Exiting SP Mode*

- Press "Exit" on the operation panel twice to return to the copy window.



#### 3.1.2 TYPES OF SP MODES

- System SP: SP modes related to the engine functions
- Printer SP: SP modes related to the controller functions
- Scanner SP: SP modes related to the scanner functions
- Fax SP: SP modes related to the fax functions

Select one of the Service Program modes (System, Printer, Scanner, or Fax) from the touch panel as shown in the diagram below after you access the SP mode. This section explains the functions of the System/Printer/Scanner SP modes. Refer to the Fax service manual for the Fax SP modes.

**SP Mode Button Summary**

Here is a short summary of the touch-panel buttons.

1	Opens all SP groups and sublevels.
2	Closes all open groups and sublevels and restores the initial SP mode display.
3	Opens the copy window (copy mode) so you can make test copies. Press SP Mode (highlighted) in the copy window to return to the SP mode screen,
4	Enter the SP code directly with the number keys if you know the SP number. Then press  . (The required SP Mode number will be highlighted when pressing  . If not, just press the required SP Mode number.)
5	Press two times to leave the SP mode and return to the copy window to resume normal operation.
6	Press any Class 1 number to open a list of Class 2 SP modes.
7	Press to scroll the show to the previous or next group.
8	Press to scroll to the previous or next display in segments the size of the screen display (page).
9	Press to scroll the show the previous or next line (line by line).
10	Press to move the highlight on the left to the previous or next selection in the list.

### ***Switching Between SP Mode and Copy Mode for Test Printing***



1. In the SP mode, select the test print. Then press "Copy Window".
2. Use the copy window (copier mode), to select the appropriate settings (paper size, etc.) for the test print.
3. Press Start  to start the test print.
4. Press SP Mode (highlighted) to return to the SP mode screen and repeat from step 1.

### ***Selecting the Program Number***

Program numbers have two or three levels.

1. Refer to the Service Tables to find the SP that you want to adjust before you begin.
2. Press the Group number on the left side SP Mode window that contains the SP that you want to adjust.
3. Use the scrolling buttons in the center of the SP mode window to show the SP number that you want to open. Then press that number to expand the list.
4. Use the center touch-panel buttons to scroll to the number and title of the item that you want to set and press it. The small entry box on the right activates and shows the below default or the current settings.

#### Note

- Refer to the Service Tables for the range of allowed settings.
5. **Do this procedure to enter a setting:**
    - Press  to toggle between plus and minus and use the keypad to enter the appropriate number. The number you enter writes over the previous setting.
    - Press  to enter the setting. (The value is not registered if you enter a number that is out of range.)
    - Press "Yes" when you are prompted to complete the selection.
  6. **If you need to perform a test print, press Copy Window to open the copy window and select the settings for the test print. Press Start  and then press SP Mode (highlighted) in the copy window to return to the SP mode display.**
  7. Press Exit two times to return to the copy window when you are finished.

### ***Exiting Service Mode***

- Press the Exit key on the touch-panel.

### **Service Mode Lock/Unlock**

At locations where the machine contains sensitive data, the customer engineer cannot operate the machine until the Administrator turns the service mode lock off. This function makes sure that work on the machine is always done with the permission of the Administrator.

1. **If you cannot go into the SP mode, ask the Administrator to log in with the User Tool and then set "Service Mode Lock" to OFF after he or she logs in: User Tools → System Settings → Administrator Tools → Service Mode Lock → OFF**
  - This unlocks the machine and lets you get access to all the SP codes.
  - The CE can service the machine and turn the machine off and on. It is not necessary to ask the Administrator to log in again each time the machine is turned on.
2. **Go into the SP mode and set SP5169 to "1" if you must use the printer bit switches.**
3. **After machine servicing is completed:**
  - Change SP5169 from "1" to "0".
  - Turn the machine off and on. Tell the administrator that you have completed servicing the machine.
  - The Administrator will then set the "Service Mode Lock" to ON.

### **3.1.3 REMARKS**

#### ***Display on the Operation Panel Screen***

The maximum number of characters which can show on the operation panel screen is limited. For this reason, some of the SP modes shown on the screen need to be abbreviated. The following are abbreviations used for the SP modes for which the full description is over 20 characters.

<p><b>Paper Weight</b>                  Plain Paper 1: 60-74 g/m<sup>2</sup>, 16-20lb.                  Plain Paper 2: 75-81 g/m<sup>2</sup>, 20-22lb.                  Middle Thick: 82-105 g/m<sup>2</sup>, 22-28lb.                  Thick Paper 1: 106-130 g/m<sup>2</sup>, 28.3-34.6lb.                  Thick Paper 2: 131-163 g/m<sup>2</sup>, 35-43lb.                  Thick Paper 3: 164-220 g/m<sup>2</sup>, 44-58lb.</p>	
<p><b>Paper Type</b>                  N: Normal paper                  MTH: Middle thick paper                  TH: Thick paper</p>	<p><b>Paper Feed Station</b>                  P: Paper tray                  B: By-pass table</p>

<b>Print Mode</b> S: Simplex D: Duplex	<b>Process Speed</b> L: Low speed (89 mm/s) M: Middle speed (178 mm/s)
--	--

## Others

The following symbols are used in the SP mode tables.

- The settings of each SP mode are explained in the right-hand column of the SP table in the following way.

[Adjustable range / **Default setting** / Step] Alphanumeric

### ↓ Note

- If "Alphanumeric" is written to the right of the bracket as shown above, the setting of the SP mode shows on the screen using alphanumeric characters instead of only numbers. However, the settings in the bracket in the SP mode table are explained by using only the numbers.
- An asterisk (\*) to the right hand side of the mode number column means that this mode is stored in the NVRAM and EEPROM. If you do a RAM clear, this SP mode will be reset to the default value. "ENG" and "CTL" show which NVRAM contains the data.
  - ENG: EEPROM on the BICU board
  - CTL: NVRAM on the controller board
- A sharp (#) to the right hand side of the mode number column means that the main power must be turned OFF and ON to effect the setting change.
- **FA**: Factory setting  
(Data may be adjusted from the default setting at the factory. Refer to the factory setting sheets enclosed.)

## 3.2 MAIN SP TABLES-1

### 3.2.1 SP1-XXX (FEED)

<b>1001</b>	<b>[Leading Edge Registration]</b>		
1-001-002	Tray: Plain	ENG*	[-9 to 9 / <b>0</b> / 0.1 mm / step]
1-001-003	Tray: Middle Thick	ENG*	[-9 to 9 / <b>0</b> / 0.1 mm / step]
1-001-004	Tray: Thick	ENG*	[-9 to 9 / <b>0</b> / 0.1 mm / step]
1-001-007	Bypass: Plain	ENG*	[-9 to 9 / <b>0</b> / 0.1 mm / step]
1-001-008	Bypass: Middle Thick	ENG*	[-9 to 9 / <b>0</b> / 0.1 mm / step]
1-001-009	Bypass: Thick	ENG*	[-9 to 9 / <b>0</b> / 0.1 mm / step]
1-001-013	Duplex: Plain	ENG*	[-9 to 9 / <b>0</b> / 0.1 mm / step]
1-001-014	Duplex: Middle Thick	ENG*	[-9 to 9 / <b>0</b> / 0.1 mm / step]
1-001-015	Duplex: Thick	ENG*	[-9 to 9 / <b>0</b> / 0.1 mm / step]

<b>1002</b>	<b>[Side-to-Side Registration]</b>		
1-002-001	Bypass	ENG*	[-4 to 4 / <b>0</b> / 0.1 mm / step]
1-002-002	Tray 1	ENG*	[-4 to 4 / <b>0</b> / 0.1 mm / step]
1-002-004	Tray 2	ENG*	[-4 to 4 / <b>0</b> / 0.1 mm / step]
1-002-006	Duplex	ENG*	[-4 to 4 / <b>0</b> / 0.1 mm / step]

<b>1003</b>	<b>[Paper Buckle Adjustment]</b>		
1-003-002	Tray1: Plain	ENG*	[-9 to 5 / <b>0</b> / 1 mm / step]
1-003-003	Tray1: Middle Thick	ENG*	[-9 to 5 / <b>0</b> / 1 mm / step]
1-003-004	Tray1: Thick	ENG*	[-9 to 5 / <b>0</b> / 1 mm / step]



1-003-007	Tray2: Plain	ENG*	[-9 to 5 / <b>0</b> / 1 mm / step]
1-003-008	Tray2: Middle Thick	ENG*	[-9 to 5 / <b>0</b> / 1 mm / step]
1-003-009	Tray2: Thick	ENG*	[-9 to 5 / <b>0</b> / 1 mm / step]
1-003-012	Bypass: Plain	ENG*	[-9 to 5 / <b>0</b> / 1 mm / step]
1-003-013	Bypass: Middle Thick	ENG*	[-9 to 5 / <b>0</b> / 1 mm / step]
1-003-014	Bypass: Thick	ENG*	[-9 to 5 / <b>0</b> / 1 mm / step]
1-003-018	Duplex: Plain	ENG*	[-9 to 5 / <b>0</b> / 1 mm / step]
1-003-019	Duplex: Middle Thick	ENG*	[-9 to 5 / <b>0</b> / 1 mm / step]
1-003-020	Duplex: Thick	ENG*	[-9 to 5 / <b>0</b> / 1 mm / step]

<b>1103</b>	<b>[Reload Permit Setting]</b>		
1-103-001	0:OFF 1:ON 2:OFF+Temp Reload	ENG*	[0 to 2 / <b>0</b> / 1 / step]
1-103-002	Reload Temp.:Center	ENG*	[100 to 180 / <b>150</b> / 1 deg / step]
1-103-003	Reload Temp.:Ends	ENG*	[50 to 150 / <b>100</b> / 1 deg / step]
1-103-004	Reload Temp.:Cold:Center	ENG*	[100 to 180 / <b>150</b> / 1 deg / step]
1-103-005	Reload Temp.:Cold:Ends	ENG*	[50 to 150 / <b>100</b> / 1 deg / step]

<b>1105</b>	<b>[Fusing Temperature Adjustment]</b>		
1-105-001	Roller Center:Plain1	ENG*	[100 to 200 / <b>145</b> / 1 deg / step]
1-105-003	Roller Center:Plain2	ENG*	[100 to 200 / <b>145</b> / 1 deg / step]
1-105-005	Roller Center:M-Thick	ENG*	[100 to 200 / <b>145</b> / 1 deg / step]

## Main SP Tables-1

1-105-007	Roller Center:Thick Paper1	ENG*	[100 to 200 / <b>155</b> / 1 deg / step]
1-105-009	Roller Center:Thin	ENG*	[100 to 200 / <b>135</b> / 1 deg / step]
1-105-012	Wait Temp.: Center	ENG*	[0 to 200 / <b>145</b> / 1 deg / step]
1-105-013	Wait Temp.: Duty Control	ENG*	[0 to 200 / <b>100</b> / 1 deg / step]
1-105-014	Thresh:S1	ENG*	[0 to 50 / <b>16</b> / 1 deg / step]
1-105-015	Thresh:delta t	ENG*	[0 to 50 / <b>0</b> / 1 deg / step]
1-105-016	Low:Plain1	ENG*	[0 to 30 / <b>5</b> / 1 deg / step]
1-105-017	Low:Plain2	ENG*	[0 to 30 / <b>5</b> / 1 deg / step]
1-105-018	Low:M-Thick	ENG*	[0 to 30 / <b>5</b> / 1 deg / step]
1-105-019	Low:Thick1	ENG*	[0 to 30 / <b>10</b> / 1 deg / step]
1-105-020	Waiting:Plain1	ENG*	[0 or 1 / <b>1</b> / 1 / step]
1-105-021	Waiting:Plain2	ENG*	[0 or 1 / <b>1</b> / 1 / step]
1-105-022	Waiting:M-Thick	ENG*	[0 or 1 / <b>1</b> / 1 / step]
1-105-023	Waiting:Thick1	ENG*	[0 or 1 / <b>1</b> / 1 / step]
1-105-024	Waiting:Center Lower:Plain1:Center	ENG*	[0 to 60 / <b>60</b> / 1 deg / step]
1-105-025	Waiting:Center Lower:Plain1:Ends	ENG*	[0 to 60 / <b>60</b> / 1 deg / step]
1-105-026	Waiting:Center Lower:Plain2:Center	ENG*	[0 to 60 / <b>60</b> / 1 deg / step]
1-105-027	Waiting:Center Lower:Plain2:Ends	ENG*	[0 to 60 / <b>60</b> / 1 deg / step]
1-105-028	Waiting:Center Lower:M-Thick:Center	ENG*	[0 to 60 / <b>5</b> / 1 deg / step]
1-105-029	Waiting:Center Lower:M-Thick:Ends	ENG*	[0 to 60 / <b>60</b> / 1 deg / step]

1-105-030	Waiting:Center Lower:Thick1:Center	ENG*	[0 to 60 / <b>0</b> / 1 deg / step]
1-105-031	Waiting:Center Lower:Thick1:Ends	ENG*	[0 to 60 / <b>60</b> / 1 deg / step]
1-105-032	Waiting:Center Upper:Plain1:Center	ENG*	[0 to 60 / <b>40</b> / 1 deg / step]
1-105-033	Waiting:Center Upper:Plain1:Ends	ENG*	[0 to 60 / <b>40</b> / 1 deg / step]
1-105-034	Waiting:Center Upper:Plain2:Center	ENG*	[0 to 60 / <b>40</b> / 1 deg / step]
1-105-035	Waiting:Center Upper:Plain2:Ends	ENG*	[0 to 60 / <b>40</b> / 1 deg / step]
1-105-036	Waiting:Center Upper:M-Thick:Center	ENG*	[0 to 60 / <b>40</b> / 1 deg / step]
1-105-037	Waiting:Center Upper:M-Thick:Ends	ENG*	[0 to 60 / <b>40</b> / 1 deg / step]
1-105-038	Waiting:Center Upper:Thick1:Center	ENG*	[0 to 60 / <b>40</b> / 1 deg / step]
1-105-039	Waiting:Center Upper:Thick1:Ends	ENG*	[0 to 60 / <b>40</b> / 1 deg / step]
1-105-040	Low:Thin	ENG*	[0 to 30 / <b>5</b> / 1 deg / step]
1-105-041	Registration Waiting:Thin	ENG*	[0 or 1 / <b>1</b> / 1 / step]
1-105-042	Waiting:Center Lower:Thin:Center	ENG*	[0 to 60 / <b>60</b> / 1 deg / step]
1-105-043	Waiting:Center Lower:Thin:Ends	ENG*	[0 to 60 / <b>60</b> / 1 deg / step]
1-105-044	Waiting:Center Upper:Thin:Center	ENG*	[0 to 60 / <b>40</b> / 1 deg / step]
1-105-045	Waiting:Center Upper:Thin:Ends	ENG*	[0 to 60 / <b>40</b> / 1 deg / step]

## Main SP Tables-1

1-105-046	Print Ready:Center	ENG*	[120 to 180 / <b>170</b> / 1 deg / step]
1-105-048	Roller Center:Thick Paper2	ENG*	[100 to 200 / <b>160</b> / 1 deg / step]
1-105-049	Roller Center:Thick Paper3	ENG*	[100 to 200 / <b>160</b> / 1 deg / step]
1-105-050	Low:Thick2	ENG*	[0 to 30 / <b>10</b> / 1 deg / step]
1-105-051	Low:Thick3	ENG*	[0 to 30 / <b>10</b> / 1 deg / step]
1-105-052	Registration Waiting:Thick2	ENG*	[0 or 1 / <b>1</b> / 1 / step]
1-105-053	Registration Waiting:Thick3	ENG*	[0 or 1 / <b>1</b> / 1 / step]
1-105-054	Waiting:Center Lower:Thick2:Center	ENG*	[0 to 60 / <b>0</b> / 1 deg / step]
1-105-055	Waiting:Center Lower:Thick2:Ends	ENG*	[0 to 60 / <b>60</b> / 1 deg / step]
1-105-056	Waiting:Center Upper:Thick2:Center	ENG*	[0 to 60 / <b>40</b> / 1 deg / step]
1-105-057	Waiting:Center Upper:Thick2:Ends	ENG*	[0 to 60 / <b>40</b> / 1 deg / step]
1-105-058	Waiting:Center Lower:Thick3:Center	ENG*	[0 to 60 / <b>0</b> / 1 deg / step]
1-105-059	Waiting:Center Lower:Thick3:Ends	ENG*	[0 to 60 / <b>60</b> / 1 deg / step]
1-105-060	Waiting:Center Upper:Thick3:Center	ENG*	[0 to 60 / <b>40</b> / 1 deg / step]
1-105-061	Waiting:Center Upper:Thick3:Ends	ENG*	[0 to 60 / <b>40</b> / 1 deg / step]
1-105-062	Low Voltage: Roller Center	ENG*	[0 to 200 / <b>130</b> / 1 deg / step]

1-105-063	Roller Center:Plain1:LowSpeed	ENG*	[100 to 200 / <b>140</b> / 1 deg / step]
1-105-064	Roller Center:Plain2:LowSpeed	ENG*	[100 to 200 / <b>140</b> / 1 deg / step]
1-105-065	Roller Center:Thin:LowSpeed	ENG*	[100 to 200 / <b>130</b> / 1 deg / step]

<b>1106</b>	<b>[Fusing Temperature Display]</b>		
1-106-001	Roller Center	ENG*	[-20 to 250 / <b>0</b> / 1 deg / step]
1-106-002	Roller Ends	ENG*	[-20 to 250 / <b>0</b> / 1 deg / step]
1-106-003	In The Machine at Power On	ENG*	[-20 to 250 / <b>0</b> / 1 deg / step]

<b>1108</b>	<b>[Fusing Soft Start Setting]</b>		
1-108-001	Warming-up	ENG*	[100 to 2000 / <b>1000</b> / 100 msec / step]
1-108-002	Print	ENG*	[100 to 2000 / <b>1000</b> / 100 msec / step]
1-108-003	Wait	ENG*	[100 to 2000 / <b>1000</b> / 100 msec / step]
1-108-004	Print Start	ENG*	[100 to 2000 / <b>200</b> / 100 msec / step]
1-108-005	Print Start Time	ENG*	[0 to 999 / <b>5</b> / 1 sec / step]

<b>1112</b>	<b>[Image Process Temp. Correction]</b>		
1-112-001	Temp. :Normal:Level1	ENG*	[-25 to 10 / <b>0</b> / 1 deg / step]
1-112-002	Temp. :Normal:Level2	ENG*	[-25 to 10 / <b>-5</b> / 1 deg / step]

<b>1123</b>	<b>[Repeat Temp. Correction]</b>		
1-123-004	1st Threshold Temp. :A4	ENG*	[100 to 250 / <b>200</b> / 1 deg / step]
1-123-005	2nd Threshold Temp. :A4	ENG*	[100 to 250 / <b>210</b> / 1 deg / step]

Main SP Tables-1

1-123-006	3rd Threshold Temp. :A4	ENG*	[100 to 250 / <b>240</b> / 1 deg / step]
1-123-007	1st Threshold Temp. :B5	ENG*	[100 to 250 / <b>200</b> / 1 deg / step]
1-123-008	2nd Threshold Temp. :B5	ENG*	[100 to 250 / <b>210</b> / 1 deg / step]
1-123-009	3rd Threshold Temp. :B5	ENG*	[100 to 250 / <b>240</b> / 1 deg / step]
1-123-010	1st Threshold Temp. :A5	ENG*	[100 to 250 / <b>200</b> / 1 deg / step]
1-123-011	2nd Threshold Temp. :A5	ENG*	[100 to 250 / <b>210</b> / 1 deg / step]
1-123-012	3rd Threshold Temp. :A5	ENG*	[100 to 250 / <b>240</b> / 1 deg / step]
1-123-013	1st Threshold Temp. :A6	ENG*	[100 to 250 / <b>200</b> / 1 deg / step]
1-123-014	2nd Threshold Temp. :A6	ENG*	[100 to 250 / <b>210</b> / 1 deg / step]
1-123-015	3rd Threshold Temp. :A6	ENG*	[100 to 250 / <b>240</b> / 1 deg / step]

<b>1124</b>	<b>[CPM Down Setting]</b>		
1-124-002	Low:Up Temp	ENG*	[-50 to 0 / <b>-5</b> / 1 deg / step]
1-124-003	Low: 1st CPM	ENG*	[10 to 100 / <b>75</b> / 5% / step]
1-124-004	Low: 2nd CPM	ENG*	[10 to 100 / <b>65</b> / 5% / step]
1-124-005	Low: 3rd CPM	ENG*	[10 to 100 / <b>40</b> / 5% / step]
1-124-024	Judging Interval	ENG*	[1 to 250 / <b>10</b> / 1 sec / step]
1-124-025	Start Timing	ENG*	[1 to 999 / <b>10</b> / 1 sec / step]
1-124-140	High: 1st CPM	ENG*	[10 to 100 / <b>50</b> / 1% / step]

1-124-141	High: 2nd CPM	ENG*	[10 to 100 / <b>30</b> / 1% / step]
1-124-142	High: 3rd CPM	ENG*	[10 to 100 / <b>30</b> / 1% / step]
1-124-143	High:1st CPM Down Temp.:A3	ENG*	[100 to 250 / <b>220</b> / 1 deg / step]
1-124-144	High:2nd CPM Down Temp.:A3	ENG*	[100 to 250 / <b>220</b> / 1 deg / step]
1-124-145	High:3rd CPM Down Temp.:A3	ENG*	[100 to 250 / <b>220</b> / 1 deg / step]
1-124-146	High:1st CPM Down Temp.:A4	ENG*	[100 to 250 / <b>220</b> / 1 deg / step]
1-124-147	High:2nd CPM Down Temp.:A4	ENG*	[100 to 250 / <b>220</b> / 1 deg / step]
1-124-148	High:3rd CPM Down Temp.:A4	ENG*	[100 to 250 / <b>220</b> / 1 deg / step]
1-124-149	High:1st CPM Down Temp.:B5	ENG*	[100 to 250 / <b>220</b> / 1 deg / step]
1-124-150	High:2nd CPM Down Temp.:B5	ENG*	[100 to 250 / <b>220</b> / 1 deg / step]
1-124-151	High:3rd CPM Down Temp.:B5	ENG*	[100 to 250 / <b>220</b> / 1 deg / step]
1-124-152	High:1st CPM Down Temp.:A5	ENG*	[100 to 250 / <b>220</b> / 1 deg / step]
1-124-153	High:2nd CPM Down Temp.:A5	ENG*	[100 to 250 / <b>220</b> / 1 deg / step]
1-124-154	High:3rd CPM Down Temp.:A5	ENG*	[100 to 250 / <b>220</b> / 1 deg / step]
1-124-155	High:1st CPM Down Temp.:A6	ENG*	[100 to 250 / <b>220</b> / 1 deg / step]
1-124-156	High:2nd CPM Down Temp.:A6	ENG*	[100 to 250 / <b>220</b> / 1 deg / step]

## Main SP Tables-1

1-124-157	High:3rd CPM Down Temp.:A6	ENG*	[100 to 250 / <b>220</b> / 1 deg / step]
-----------	-------------------------------	------	--

<b>1135</b>	<b>[Inrush/Flicker Control]</b>		
1-135-001	Inrush Control	ENG*	[0 or 1 / <b>0</b> / 1 / step]
1-135-002	Control Flicker Control	ENG*	[0 or 1 / <b>0</b> / 1 / step]

<b>1152</b>	<b>[Fusing Nip Band Check]</b>		
1-152-001	0:OFF 1:ON	ENG	[0 or 1 / <b>0</b> / 1 / step]
1-152-002	Pre-idling Time	ENG*	[0 to 999 / <b>300</b> / 1 sec / step]
1-152-003	Stop Time	ENG*	[0 to 100 / <b>20</b> / 1 sec / step]

<b>1159</b>	<b>[Fusing Jam Detection]</b>		
1-159-001	SC Display	ENG*	[0 or 1 / <b>0</b> / 1 / step]

<b>1903</b>	<b>[Feed CI Re-energize]</b>		
1-903-001	Tray1 Feed	ENG*	[-10 to 30 / <b>0</b> / 1 mm / step]
1-903-002	Bypass Feed	ENG*	[-30 to 30 / <b>0</b> / 1 mm / step]

<b>1907</b>	<b>[Paper Feed Timing Adj.]</b>		
1-907-001	FWD CL Stop Position	ENG*	[-12 to 12 / <b>0</b> / 1 mm / step]
1-907-002	FWD CL Start Position	ENG*	[-10 to 20 / <b>0</b> / 1 mm / step]
1-907-003	FWD CL Stop Position: Duplex	ENG*	[-7 to 7 / <b>0</b> / 1 mm / step]
1-907-004	RVS CL Start Timing: Duplex	ENG*	[0 to 150 / <b>0</b> / 10 msec / step]



1-907-005	Duplex: Wait Position1	ENG*	[-10 to 10 / <b>0</b> / 1 mm / step]
1-907-006	Duplex: Wait Position2	ENG*	[-10 to 10 / <b>0</b> / 1 mm / step]

<b>1911</b>	<b>[By-Pass Envelope]</b>		
1-911-001	By-Pass Envelope	ENG*	[0 or 1 / <b>0</b> / 1 / step] 0: Disable, 1: Enable

<b>1960</b>	<b>[High Productivity Mode Setting]</b>		
1-960-001	Standard Mode A	ENG	[0 or 1 / <b>0</b> / 1 / step]
1-960-002	High Productivity Mode A	ENG	[0 or 1 / <b>0</b> / 1 / step]
1-960-003	High Productivity Mode B	ENG	[0 or 1 / <b>0</b> / 1 / step]
1-960-004	High Productivity Mode C	ENG	[0 or 1 / <b>0</b> / 1 / step]

<b>1990</b>	<b>[SC990 plt detail]</b>		
1-990-001	-	ENG*	[0 to 4294967295 / <b>0</b> / 1 / step]

<b>1991</b>	<b>[Max Fusing Lamp Duty]</b>		
1-991-001	Roller Center	ENG*	[40 to 100 / <b>100</b> / 10% / step]
1-991-003	After Warming-up – Center	ENG*	[40 to 100 / <b>100</b> / 10% / step]

<b>1996</b>	<b>[Heater Forced Off]</b>		
1-996-005	Time Heater OFF	ENG*	[0 to 120 / <b>7</b> / 1 sec / step]

### 3.3 MAIN SP TABLES-2

#### 3.3.1 SP2-XXX (DRUM)

<b>2011</b>	<b>[Manual ProCon]</b>		
2-011-001	Exe Normal ProCon	ENG	[0 to 1 / <b>0</b> / 1 / step]

<b>2101</b>	<b>[Registration Correction]</b>		
2-101-001	Main Dot	ENG*	[-512 to 511 / <b>0</b> / 1 dot / step]

<b>2102</b>	<b>[Main Scan Mag. Adjustment]</b>		
2-102-001	-	ENG*	[-0.5 to 0.5 / <b>0</b> / 0.1% / step]

<b>2103</b>	<b>[Erase Margin Adjustment]</b>		
2-103-001	Leading Edge	ENG	[0 to 9 / <b>3</b> / 0.1 mm / step]
2-103-002	Trailing Edge	ENG	[0 to 9 / <b>3</b> / 0.1 mm / step]
2-103-003	Left	ENG	[0 to 9 / <b>2</b> / 0.1 mm / step]
2-103-004	Right	ENG	[0 to 9 / <b>2</b> / 0.1 mm / step]
2-103-005	Duplex Trail. Edge: L Size: Plain	ENG	[0 to 4 / <b>1.2</b> / 0.1 mm / step]
2-103-006	Duplex Trail. Edge: M Size: Plain	ENG	[0 to 4 / <b>0.8</b> / 0.1 mm / step]
2-103-007	Duplex. Trail. Edge: S Size: Plain	ENG	[0 to 4 / <b>0.6</b> / 0.1 mm / step]
2-103-008	Duplex Left: Plain	ENG	[0 to 1.5 / <b>0.3</b> / 0.1 mm / step]
2-103-009	Duplex Right: Plain	ENG	[0 to 1.5 / <b>0.3</b> / 0.1 mm / step]
2-103-010	Duplex Trail. Edge: L Size: Thick	ENG	[0 to 4 / <b>1</b> / 0.1 mm / step]

2-103-011	Duplex Trail. Edge: M Size: Thick	ENG	[0 to 4 / <b>0.6</b> / 0.1 mm / step]
2-103-012	Duplex Trail. Edge: S Size: Thick	ENG	[0 to 4 / <b>0.4</b> / 0.1 mm / step]
2-103-013	Duplex Left: Thick	ENG	[0 to 1.5 / <b>0.1</b> / 0.1 mm / step]
2-103-014	Duplex Right: Thick	ENG	[0 to 1.5 / <b>0.1</b> / 0.1 mm / step]

<b>2107</b>	<b>[Image Parameter]</b>		
2-107-001	Image Gamma Flag	ENG*	[0 or 1 / <b>1</b> / 1 / step] 0: OFF, 1: ON
2-107-002	Shading Correction Flag	ENG*	[0 or 1 / <b>0</b> / 1 / step] 0: ON, 1: OFF

2109	[Test Pattern]		
2-109-001	Pattern Select	ENG	<p>[0 to 24 / <b>0</b> / 1 / step]</p> <p>0: None</p> <p>1: Vertical Line (1dot)</p> <p>2: Vertical Line (2dot)</p> <p>3: Horizontal Line (1dot)</p> <p>4: Horizontal Line (2dot)</p> <p>5: Grid Vertical Line</p> <p>6: Grid Horizontal Line</p> <p>7: Grid Pattern Small</p> <p>8: Grid Pattern Large</p> <p>9: Argyle Pattern Small</p> <p>10: Argyle Pattern Large</p> <p>11: Independent Pattern (1dot)</p> <p>12: Independent Pattern (2dot)</p> <p>13: Independent Pattern (4dot)</p> <p>14: Trimming Area</p> <p>15: Hound's Tooth Check (Vertical)</p> <p>16: Hound's Tooth Check (Horizontal)</p> <p>17: Black Band (Horizontal)</p> <p>18: Black Band (Vertical)</p> <p>19: Checker Flag Pattern</p> <p>20: Grayscale (Vertical)</p> <p>21: Grayscale (Horizontal)</p> <p>22: Two Beam Density Pattern</p> <p>23: Full Dot Pattern</p> <p>24: All White Pattern</p>
2-109-002	Test Pattern Density	ENG	<p>[0 to 15 / <b>15</b> / 1 / step]</p> <p>1: N: Normal</p> <p>2: H: Dark</p> <p>3: L: Light</p> <p>4: HH: Much Darker</p> <p>5: LL: Much Lighter</p>

<b>2110</b>	<b>[LD Driver]</b>		
2-110-001	Error Flag	ENG*	[0x00 to 0xFF / <b>0x00</b> / 1 / step]
2-110-005	Memory Transfer	ENG	[0 or 1 / <b>0</b> / 1 / step]

<b>2160</b>	<b>[Vertical Line Width]</b>		
2-160-001	1dot Line	ENG*	[0 to 31 / <b>31</b> / 1 / step]

<b>2201</b>	<b>[Development Bias Adjust]</b>		
2-201-002	ID Sensor Pattern Correction	ENG*	[0 to 4 / <b>0</b> / 1 / step]

<b>2220</b>	<b>[Process Data Display]</b>		
2-220-001	Vsp	ENG*	[0 to 9.99 / <b>0</b> / 0.01 vol / step]
2-220-002	Vsg	ENG*	[0 to 9.99 / <b>0</b> / 0.01 vol / step]
2-220-003	Vsdp	ENG*	[0 to 9.99 / <b>0</b> / 0.01 vol / step]
2-220-004	Vt	ENG*	[0 to 9.99 / <b>0</b> / 0.01 vol / step]
2-220-005	Vtref	ENG*	[0 to 9.99 / <b>2.5</b> / 0.01 vol / step]

<b>2241</b>	<b>[Image Process Temp. : Display]</b>		
2-241-004	Display Image Process Temp Display	ENG	[0 to 70 / <b>0</b> / 0.1 deg / step]

<b>2242</b>	<b>[TS Operation Env. Log]</b>		
2-242-001	TS<=A	ENG*	[0 to 999999999 / 0 / 1 mm / step]
2-242-002	A<TS<=B	ENG*	[0 to 999999999 / 0 / 1 mm / step]
2-242-003	B<TS	ENG*	[0 to 999999999 / 0 / 1 mm / step]
2-242-100	Log Clear	ENG	[0 or 1 / 0 / 1 / step]

<b>2243</b>	<b>[Temperature/Humidity: Display]</b>		
2-243-001	Temperature	ENG	[-5 to 45 / 0 / 0.1 deg / step]
2-243-002	Relative Humidity	ENG	[0 to 100 / 0 / 1%RH / step]
2-243-003	Absolute Humidity	ENG	[0 to 100 / 0 / 1 g/m3 / step]

<b>2302</b>	<b>[Environment Correct: Transfer]</b>		
2-302-001	Current Env. : Display	ENG	[0 to 0 / 0 / 0 / step]

<b>2303</b>	<b>[Age Correction]</b>		
2-303-001	Current Div K	ENG*	[0 to 3 / 0 / 1 / step]

<b>2700</b>	<b>[New Unit Detection]</b>		
2-700-001	ON/OFF Setting	ENG*	[0 or 1 / 1 / 1 / step] 0: OFF, 1: ON

<b>2701</b>	<b>[Manual New Unit Set]</b>		
2-701-108	120k Part	ENG*	[0 or 1 / 0 / 1 / step]

<b>2801</b>	<b>[Developer Initialization]</b>		
2-801-001	Init. TD Sensor Set: Execute	ENG	[0 or 1 / 0 / 0 / step]

<b>2802</b>	<b>[Developer Mixing]</b>		
2-802-001	-	ENG	[0 or 1 / <b>0</b> / 0 / step]

<b>2803</b>	<b>[Developer Initialization Data]</b>		
2-803-001	Vtref	ENG*	[0 to 9.99 / <b>2.5</b> / 0.01 vol / step]
2-803-002	ID Sensor PWM Value	ENG*	[0 to 1023 / <b>0</b> / 1 / step]
2-803-007	Initial Abs. Humidity	ENG*	[0 to 100 / <b>10</b> / 1 g/m3 / step]

<b>2804</b>	<b>[Total Image Area: Display]</b>		
2-804-001	Latest	ENG*	[0 to 4294967295 / <b>0</b> / 1 cm2 / step]

<b>2906</b>	<b>[Tailing Control]</b>		
2-906-001	Shift Range	ENG*	[0 or 1 / <b>0</b> / 0.1 mm / step]
2-906-002	Number of Sheets	ENG*	[0 to 10 / <b>0</b> / 1 sheets / step]

<b>2908</b>	<b>[Forced Toner Supply]</b>		
2-908-001	-	ENG	[0 or 1 / <b>0</b> / 0 / step]

<b>2909</b>	<b>[Filling Mode]</b>		
2-909-001	Init. Toner Replenish Exe Flag	ENG*	[0 or 1 / <b>0</b> / 1 / step]

<b>2915</b>	<b>[Polygon Rotate Time]</b>		
2-915-001	Idling Time ADJ	ENG*	[0 to 60 / <b>10</b> / 1 sec / step]
2-915-002	Post Idling Time ADJ	ENG*	[0 to 60 / <b>0</b> / 1 sec / step]

Main SP Tables-2

<b>2921</b>	<b>[Toner Supply Mode]</b>		
2-921-001	Mode Select	ENG*	[0 to 4 / <b>0</b> / 1 / step] 0: Normal1 1: Normal2 2: Fixed1 3: Fixed2

<b>2936</b>	<b>[ID Sensor Detection]</b>		
2-936-001	Interval Counter	ENG*	[0 to 999 / <b>0</b> / 1 page / step]



## **3.4 MAIN SP TABLES-3**

### **3.4.1 SP3-XXX (PROCESS)**

None

## 3.5 MAIN SP TABLES-4

### 3.5.1 SP4-XXX (SCANNER)

<b>4008</b>	<b>[Sub Scan Mag. Adjustment]</b>		
4-008-001	-	ENG*	[-1 to 1 / <b>0</b> / 0.1 % / step]

<b>4010</b>	<b>[Sub Scan Regist Adjustment]</b>		
4-010-001	-	ENG*	[-1 to 1 / <b>0</b> / 0.1 mm / step]

<b>4011</b>	<b>[Main Scan Regist Adjustment]</b>		
4-011-001	-	ENG*	[-2 to 2 / <b>0</b> / 0.1 mm / step]

<b>4012</b>	<b>[Scanner Erase Margin: Scale]</b>		
4-012-001	Book: Sub Scan: Lead Edge	ENG*	[0 to 3 / <b>1</b> / 0.1 mm / step]
4-012-002	Book: Sub Scan: Trail Edge	ENG*	[0 to 3 / <b>0</b> / 0.1 mm / step]
4-012-003	Book: Main Scan: Lead Edge	ENG*	[0 to 3 / <b>1</b> / 0.1 mm / step]
4-012-004	Book: Main Scan: Trail Edge	ENG*	[0 to 3 / <b>0</b> / 0.1 mm / step]

<b>4020</b>	<b>[DF Dust Check]</b>		
4-020-001	Dust Detect:On/Off	ENG	[0 or 1 / <b>1</b> / 1 / step]
4-020-002	Dust Detect:Lvl	ENG	[0 to 8 / <b>4</b> / 1 / step]
4-020-003	Dust Reject:Lvl	ENG	[0 to 4 / <b>0</b> / 1 / step]

<b>4301</b>	<b>[Operation Check APS Sensor]</b>		
4-301-001	-	ENG	[0 to 255 / <b>0</b> / 1 / step]

<b>4303</b>	<b>[Min Size for APS]</b>		
4-303-001	-	ENG*	[0 to 2 / <b>0</b> / 1 / step] 0: No Original 1: A5 SEF 2: A5 LEF

<b>4305</b>	<b>[APS Detection Setting]</b>		
4-305-001	-	ENG*	[0 or 1 / <b>0</b> / 1 / step] 0: Normal Detection 1: 8K 16K

<b>4400</b>	<b>[Scanner Erase Margin]</b>		
4-400-001	Book: Sub Scan: Leading Edge	ENG*	[0 to 3 / <b>0</b> / 0.1 mm / step]
4-400-002	Book: Sub Scan: Trailing Edge	ENG*	[0 to 3 / <b>0</b> / 0.1 mm / step]
4-400-003	Book: Main Scan: Left	ENG*	[0 to 3 / <b>0</b> / 0.1 mm / step]
4-400-004	Book: Main Scan: Right	ENG*	[0 to 3 / <b>0</b> / 0.1 mm / step]
4-400-005	ADF: Sub Scan: Trailing Edge	ENG*	[0 to 3 / <b>0</b> / 0.1 mm / step]
4-400-007	ADF: Main Scan: Left	ENG*	[0 to 3 / <b>0</b> / 0.1 mm / step]
4-400-008	ADF: Main Scan: Right	ENG*	[0 to 3 / <b>0</b> / 0.1 mm / step]

<b>4417</b>	<b>[IPU Test Pattern]</b>		
4-417-001	Test Pattern	ENG	[0 to 8 / <b>0</b> / 1 / step] 0: Scanned image 1: 256 Gradation: Main scan A 2: Patch 16 C 3: Grid pattern A 4: Slant grid pattern B 5: Slant grid pattern C 6: Slant grid pattern D 7: Scanned+Slant Grid C 8: Scanned+Slant Grid D

<b>4429</b>	<b>[Select Copy Data Security]</b>		
4-429-001	Copying	ENG	[0 to 3 / <b>3</b> / 1 / step]
4-429-002	Scanning	ENG	[0 to 3 / <b>3</b> / 1 / step]
4-429-003	Fax Operation	ENG	[0 to 3 / <b>3</b> / 1 / step]

<b>4606</b>	<b>[White Level Adjust]</b>		
4-606-001	Color	ENG*	[0 to 1024 / <b>707</b> / 1 digit / step]

<b>4607</b>	<b>[White Level Adjust]</b>		
4-607-001	Bk	ENG*	[0 to 1024 / <b>707</b> / 1 digit / step]

<b>4609</b>	<b>[Gray Balance Set: R]</b>		
4-609-001	Book Scan	ENG*	[-384 to 255 / <b>-89</b> / 1 digit / step]
4-609-002	DF Scan	ENG*	[-384 to 255 / <b>-89</b> / 1 digit / step]

<b>4610</b>	<b>[Gray Balance Set: G]</b>		
4-610-001	Book Scan	ENG*	[-384 to 255 / <b>-76</b> / 1 digit / step]
4-610-002	DF Scan	ENG*	[-384 to 255 / <b>-76</b> / 1 digit / step]

4-610-003	Book Scan(Bk)	ENG*	[-384 to 255 / <b>-92</b> / 1 digit / step]
4-610-004	DF Scan(Bk)	ENG*	[-384 to 255 / <b>-92</b> / 1 digit / step]

<b>4611</b>	<b>[Gray Balance Set: B]</b>		
4-611-001	Book Scan	ENG*	[-384 to 255 / <b>-85</b> / 1 digit / step]
4-611-002	DF Scan	ENG*	[-384 to 255 / <b>-85</b> / 1 digit / step]

<b>4645</b>	<b>[Scan Adjust Error]</b>		
4-645-001	White level	ENG	[0 to 65535 / <b>0</b> / 1 / step]
4-645-002	Black level	ENG	[0 to 65535 / <b>0</b> / 1 / step]

<b>4647</b>	<b>[Scanner Hard Error]</b>		
4-647-001	Power-ON	ENG	[0 to 65535 / <b>0</b> / 1 / step]

<b>4688</b>	<b>[ADF Adjustment Density]</b>		
4-688-001	-	ENG*	[50 to 150 / <b>100</b> / 1 % / step]

<b>4803</b>	<b>[Home Position Adjustment]</b>		
4-803-001	-	ENG*	[-2.0 to 1.4 / <b>0.0</b> / 0.1 mm / step]

<b>4903</b>	<b>[Filter Setting]</b>		
4-903-001	Ind Dot Erase: Text	ENG*	[0 to 7 / <b>0</b> / 1 / step]
4-903-002	Ind Dot Erase: Generation Copy	ENG*	[0 to 7 / <b>0</b> / 1 / step]

<b>4905</b>	<b>[Select Gradation Level]</b>		
4-905-001	-	ENG*	[0 to 255 / <b>0</b> / 1 / step]

<b>4909</b>	<b>[Man Gamma:P CoIK]</b>		
4-909-001	Offset:Highlight	ENG*	[0 to 30 / <b>15</b> / 1 / step]
4-909-002	Offset:Middle	ENG*	[0 to 30 / <b>15</b> / 1 / step]
4-909-003	Offset:Shadow	ENG*	[0 to 30 / <b>15</b> / 1 / step]
4-909-004	Offset:IDmax	ENG*	[0 to 30 / <b>15</b> / 1 / step]
4-909-005	Option:Highlight	ENG*	[0 to 255 / <b>0</b> / 1 / step]
4-909-006	Option:Middle	ENG*	[0 to 12 / <b>0</b> / 1 / step]
4-909-007	Option:Shadow	ENG*	[0 to 255 / <b>0</b> / 1 / step]
4-909-008	Option:IDmax	ENG*	[0 to 255 / <b>0</b> / 1 / step]

<b>4914</b>	<b>[Man Gamma:T:CoIK]</b>		
4-914-001	Offset:Highlight	ENG*	[0 to 30 / <b>15</b> / 1 / step]
4-914-002	Offset:Middle	ENG*	[0 to 30 / <b>15</b> / 1 / step]
4-914-003	Offset:Shadow	ENG*	[0 to 30 / <b>15</b> / 1 / step]
4-914-004	Offset:IDmax	ENG*	[0 to 30 / <b>15</b> / 1 / step]
4-914-005	Option:Highlight	ENG*	[0 to 255 / <b>0</b> / 1 / step]
4-914-006	Option:Middle	ENG*	[0 to 12 / <b>0</b> / 1 / step]
4-914-007	Option:Shadow	ENG*	[0 to 255 / <b>0</b> / 1 / step]
4-914-008	Option:IDmax	ENG*	[0 to 255 / <b>0</b> / 1 / step]

<b>4938</b>	<b>[ACS:Edge Mask]</b>		
4-938-005	Scan:Sub LEdge	ENG*	[0 to 31 / <b>15</b> / 1 / step]
4-938-006	Scan:Sub TEdge	ENG*	[0 to 31 / <b>15</b> / 1 / step]
4-938-007	Scan:Main LEdge	ENG*	[0 to 31 / <b>15</b> / 1 / step]
4-938-008	Scan:Main TEdge	ENG*	[0 to 31 / <b>15</b> / 1 / step]

<b>4939</b>	<b>[ACS:Color Range]</b>		
4-939-001	-	ENG*	[-2 to 2 / <b>0</b> / 1 / step]

<b>4991</b>	<b>[IPU Image Pass Selection]</b>		
4-991-001	RGB Frame Memory	ENG	[0 to 19 / <b>2</b> / 1 / step]

<b>4994</b>	<b>[Adj Txt/Photo Recog Level]</b>		
4-994-001	High Compression PDF	ENG*	[0 to 2 / <b>1</b> / 1 / step]

<b>4996</b>	<b>[White Paper Detection Level]</b>		
4-996-001	-	ENG	[0 to 6 / <b>3</b> / 1 / step]

## 3.6 MAIN SP TABLES-5 (ENGINE)

### 3.6.1 SP5-XXX (MODE)

<b>5126</b>	<b>[Set F-size Document]</b>		
5-126-001	-	ENG	[0 to 2 / <b>0</b> / 1 / step] 0: 8 1/2 x 13 1: 8 1/4 x 13 2: 8 x 13

<b>5131</b>	<b>[Paper Size Type Selection]</b>		
5-131-001	-	ENG*	[0 to 2 / <b>NA:1, Other:2</b> / 1 / step] 0: JP, 1: NA, 2: EU/AP/CH/TW

<b>5135</b>	<b>[LG_Oficio Change]</b>		
5-135-001	-	ENG*	[0 or 1 / <b>0</b> / 1 / step]

<b>5178</b>	<b>[Copy Data Security Setting]</b>		
5-178-001	0: OFF/1: ON	ENG*	[0 or 1 / <b>0</b> / 1 / step]

<b>5182</b>	<b>[Clutch Timing Adjust]</b>		
5-182-002	Tray2: 1	ENG*	[-10 to 10 / <b>0</b> / 1 mm / step]

<b>5183</b>	<b>[Next feed timing adjust]</b>		
5-183-002	Tray2: 1	ENG*	[-10 to 10 / <b>0</b> / 1 mm / step]

<b>5184</b>	<b>[Re-feed timing adjust]</b>		
5-184-002	Tray2: 1	ENG*	[-10 to 10 / <b>0</b> / 1 mm / step]



<b>5186</b>	<b>[RK4: Setting]</b>		
5-186-001	-	ENG*	[0 or 1 / <b>0</b> / 1 / step]

<b>5801</b>	<b>[Memory Clear]</b>		
5-801-002	Engine	ENG	[0 or 1 / <b>0</b> / 1 / step]

<b>5803</b>	<b>[INPUT Check]</b>		
5-803-001	Tray: Paper Set Sensor	ENG	[0 or 1 / <b>0</b> / 1 / step]
5-803-002	Bypass: Paper Set Sensor	ENG	[0 or 1 / <b>0</b> / 1 / step]
5-803-003	RVS: Paper Exit Sensor	ENG	[0 or 1 / <b>0</b> / 1 / step]
5-803-004	Registration Sensor	ENG	[0 or 1 / <b>0</b> / 1 / step]
5-803-005	Duplex: Exit Sensor	ENG	[0 or 1 / <b>0</b> / 1 / step]
5-803-006	Duplex: Entrance Sensor	ENG	[0 or 1 / <b>0</b> / 1 / step]
5-803-011	Front Interlock SW	ENG	[0 or 1 / <b>0</b> / 1 / step]
5-803-012	Right Interlock SW	ENG	[0 or 1 / <b>0</b> / 1 / step]
5-803-013	Exhaust Fan: Lock	ENG	[0 or 1 / <b>0</b> / 1 / step]
5-803-014	Intake Fan: Lock	ENG	[0 or 1 / <b>0</b> / 1 / step]
5-803-015	Main Motor Lock	ENG	[0 or 1 / <b>0</b> / 1 / step]
5-803-016	Key Card Set	ENG	[0 or 1 / <b>0</b> / 1 / step]
5-803-017	Key Counter Set	ENG	[0 to 3 / <b>0</b> / 1 / step]
5-803-018	BICU Version	ENG	[0 to 7 / <b>0</b> / 1 / step]
5-803-019	Right Door Open/Close Switch	ENG	[0 or 1 / <b>0</b> / 1 / step]
5-803-020	Paper Exit Sensor	ENG	[0 or 1 / <b>0</b> / 1 / step]

Main SP Tables-5 (Engine)

5-803-200	Scanner HP Sensor	ENG	[0 or 1 / 0 / 1 / step]
5-803-201	Platen Cover Sensor	ENG	[0 or 1 / 0 / 1 / step]
5-803-211	Bank1: Feed Cover Open Detection	ENG	[0 or 1 / 0 / 1 / step]
5-803-212	Bank1:Paper End Sensor	ENG	[0 or 1 / 0 / 1 / step]
5-803-213	Bank1:Feed Sensor	ENG	[0 or 1 / 0 / 1 / step]
5-803-214	Bank1:Upper Limit Sensor	ENG	[0 or 1 / 0 / 1 / step]
5-803-215	Bank1:Tray Set Sensor	ENG	[0 or 1 / 0 / 1 / step]

<b>5804</b>	<b>[OUTPUT Check]</b>		
5-804-001	Main Motor: CW: Standard Spd	ENG	[0 or 1 / 0 / 1 / step]
5-804-002	Main Motor: CW: Low Spd	ENG	[0 or 1 / 0 / 1 / step]
5-804-005	Toner Bottle Motor: CCW	ENG	[0 or 1 / 0 / 1 / step]
5-804-008	Intake Fan Motor: Full Spd	ENG	[0 or 1 / 0 / 1 / step]
5-804-009	Intake Fan Motor: Half Spd	ENG	[0 or 1 / 0 / 1 / step]
5-804-010	HVP: Transfer: -	ENG	[0 or 1 / 0 / 1 / step]
5-804-011	HVP: Transfer: +	ENG	[0 or 1 / 0 / 1 / step]
5-804-012	HVP.: Separation Voltage	ENG	[0 or 1 / 0 / 1 / step]
5-804-013	HVP.: Development	ENG	[0 or 1 / 0 / 1 / step]
5-804-014	HVP.: Charge	ENG	[0 or 1 / 0 / 1 / step]

5-804-015	Potential Sensor	ENG	[0 or 1 / 0 / 1 / step]
5-804-016	Fusing Solenoid	ENG	[0 or 1 / 0 / 1 / step]
5-804-017	Drum Quenching LED	ENG	[0 or 1 / 0 / 1 / step]
5-804-018	Paper Feed CL	ENG	[0 or 1 / 0 / 1 / step]
5-804-019	Registration CL	ENG	[0 or 1 / 0 / 1 / step]
5-804-020	Bypass CL	ENG	[0 or 1 / 0 / 1 / step]
5-804-021	Duplex: RVS Sensor CL	ENG	[0 or 1 / 0 / 1 / step]
5-804-022	Paper Exit RVS CL	ENG	[0 or 1 / 0 / 1 / step]
5-804-023	Paper Exit CL	ENG	[0 or 1 / 0 / 1 / step]
5-804-024	Anti-Condensation Heater	ENG	[0 or 1 / 0 / 1 / step]
5-804-027	Exhaust Fan Motor	ENG	[0 or 1 / 0 / 1 / step]
5-804-028	Pre Cleaning Lamp	ENG	[0 or 1 / 0 / 1 / step]
5-804-049	Polygon Motor: High Spd	ENG	[0 or 1 / 0 / 1 / step]
5-804-050	Polygon Motor: Low Spd	ENG	[0 or 1 / 0 / 1 / step]
5-804-202	Scanner Lamp: Color	ENG	[0 or 1 / 0 / 1 / step]
5-804-203	Scanner Lamp: Bk	ENG	[0 or 1 / 0 / 1 / step]
5-804-241	Bank1:Feed Motor	ENG	[0 or 1 / 0 / 1 / step]
5-804-242	Bank1:Paper feed clutch	ENG	[0 or 1 / 0 / 1 / step]

<b>5805</b>	<b>[Anti-Condensation Heater]</b>		
5-805-001	0:OFF / 1:ON	ENG*	[0 or 1 / 0 / 1 / step]

Main SP Tables-5 (Engine)

<b>5810</b>	<b>[SC Reset]</b>		
5-810-001	Fusing SC Reset	ENG	[0 or 1 / <b>0</b> / 1 / step]

<b>5811</b>	<b>[MachineSerial]</b>		
5-811-002	Display	ENG*	[0 to 255 / <b>0</b> / 1 / step] 1: DOM 2: NA 3: EU 4: TWN 5: AA 6: CHN 7: KOR

<b>5884</b>	<b>[Plain Paper 1/2 Type]</b>		
5-884-001	By-pass	ENG*	[0 or 1 / <b>1</b> / 1 / step] 0: Bypass: Plain Paper 1 1: Bypass: Plain Paper 2
5-884-002	Tray1	ENG*	[0 or 1 / <b>1</b> / 1 / step] 0: Tray 1: Plain Paper 1 1: Tray 1: Plain Paper 2
5-884-003	Tray2	ENG*	[0 or 1 / <b>1</b> / 1 / step] 0: Tray 2: Plain Paper 1 1: Tray 2: Plain Paper 2

<b>5894</b>	<b>[ExternalCountSet]</b>		
5-894-001	SW Charge Mode	ENG*	[0 to 2 / <b>0</b> / 1 / step]

<b>5900</b>	<b>[Engine Log Upload]</b>		
5-900-001	Pattern	ENG*	[0 to 4 / <b>0</b> / 1 / step]
5-900-002	Trigger	ENG*	[0 to 3 / <b>0</b> / 1 / step]

<b>5903</b>	<b>[Adj. Remaining Toner Detection]</b>		
5-903-001	Toner Bottle Motor: Total ON Time	ENG*	[0 to 99999999 / <b>0</b> / 1 msec / step]
5-903-002	Toner Remaining Amount	ENG*	[0 to 100 / <b>100</b> / 1 % / step]
5-903-004	Clear Total ON Time Count	ENG	[0 to 1 / <b>0</b> / 0 / step]
5-903-005	0:OFF 1:ON	ENG*	[0 to 1 / <b>0</b> / 1 / step]

<b>5995</b>	<b>[Factory Mode]</b>		
5-995-001	-	ENG*	[0 to 1 / <b>0</b> / 1 / step]

<b>5996</b>	<b>[Machine State]</b>		
5-996-001	Destination	ENG*	[1 to 7 / <b>1</b> / 1 / step] 1: Japan 2: NA 3: EU 4: Taiwan 5: Asia 6: China 7: Korea

### 3.7 MAIN SP TABLES-5 (CONTROLLER)

#### 3.7.1 SP5-XXX (MODE)

<b>5009</b>	<b>[Add display language]</b>		
5-009-201	1-8	CTL*	[1 to 255 / <b>0</b> / 1 / step]
5-009-202	9-16		
5-009-203	17-24		
5-009-204	25-32		
5-009-205	33-40	CTL*	[1 to 255 / <b>0</b> / 1 / step]
5-009-206	41-48		
5-009-207	49-56		

<b>5024</b>	<b>[mm/inch Display selection]</b>		
5-024-001	0:mm 1:inch	CTL*	[0 or 1 / <b>NA:1, Other:0</b> / 1 / step]

<b>5045</b>	<b>[Accounting Counter]</b>		
5-045-001	Counter Method	CTL*	[0 to 7 / <b>0</b> / 1 / step]

<b>5047</b>	<b>[Paper Display]</b>		
5-047-001	Backing Paper	CTL*	[0 or 1 / <b>0</b> / 1 / step] 0: OFF, 1:ON

<b>5055</b>	<b>[Display IP add]</b>		
5-055-001	-	CTL*	[0 or 1 / <b>0</b> / 1 / step]

<b>5062</b>	<b>[Parts Replacement Alert Display]</b>		
5-062-001	Photoconductor Unit	CTL*	[0 or 1 / 0 / 1 / step]
5-062-002	Maintenance Parts	CTL*	[0 or 1 / 0 / 1 / step]

<b>5066</b>	<b>[PM Parts Display]</b>		
5-066-001	-	CTL*	[0 or 1 / 0 / 1 / step]

<b>5067</b>	<b>[Part Replacement Operation Type]</b>		
5-067-001	Photoconductor Unit	CTL*	[0 or 1 / 0 / 1 / step]
5-067-002	Maintenance Parts	CTL*	[0 or 1 / 0 / 1 / step]

<b>5071</b>	<b>[Set Bypass Paper Size Display]</b>		
5-071-001	-	CTL	[0 or 1 / 0 / 1 / step]

<b>5074</b>	<b>[Home Key Customization]</b>		
5-074-002	Login Setting	CTL*	[0 to 255 / 0 / 1 / step]
5-074-050	Show Home Edit	CTL	[0 to 2 / 0 / 1 / step]
5-074-091	Function Setting	CTL*	[0 to 2 / 0 / 1 / step]
5-074-092	Product ID	CTL*	[0 to 0xffffffff / 0 / 1 / step]
5-074-093	Application screen ID	CTL*	[0 to 255 / 0 / 1 / step]

<b>5076</b>	<b>[Copy:LT/LG Mixed Sizes Setting]</b>		
5-076-001	0:OFF 1:ON	CTL*	[0 or 1 / 0 / 1 / step]

Main SP Tables-5 (Controller)

<b>5081</b>	<b>[ServiceSP Entry Code Setting]</b>		
5-081-001	-	CTL*	[- / - / - / step]

<b>5083</b>	<b>[LED Light Switch Setting]</b>		
5-083-001	Toner Near End	CTL*	[0 or 1 / 0 / 1 / step]

<b>5104</b>	<b>[Counter Size Setting]</b>		
5-104-001	A3/DLT Double Count	CTL*	[0 or 1 / 0 / 1 / step]
5-104-002	Bypass Paper Size Undetection	CTL*	[0 or 1 / 0 / 1 / step]

<b>5113</b>	<b>[Optional Counter Type]</b>		
5-113-001	Default Optional Counter Type	CTL*	[0 to 12 / 0 / 1 / step] 0: None, 1: Key Card(RK3,4) 2: Key Card(down), 3: PrepaidCard 4: Coin Rack 5: MFKeyCard 11: Exp.KeyCard(Add) 12: Exp.KeyCard(Deduct)
5-113-002	External Optional Counter Type	CTL*	[0 to 3 / 0 / 1 / step] 0: None 1: Expansion Device 1 2: Expansion Device 2 3: Expansion Device 3

<b>5114</b>	<b>[Optional Counter I/F]</b>		
5-114-001	MF Key Card Extension	CTL*	[0 or 1 / 0 / 1 / step] 0: Not installed 1: Installed (scanning accounting)



<b>5118</b>	<b>[Disable Copying]</b>		
5-118-001	-	CTL*	[0 or 1 / <b>0</b> / 1 / step] 0: Not disabled 1: Disabled

<b>5120</b>	<b>[Mode Clear Opt. Counter Removal]</b>		
5-120-001	-	CTL*	[0 to 2 / <b>0</b> / 1 / step] 0: Yes (removed) 1: Standby (installed but not used) 2: No (not removed)

<b>5121</b>	<b>[Counter Up Timing]</b>		
5-121-001	-	CTL*	[0 or 1 / <b>0</b> / 1 / step] 0: Feed 1: Exit

<b>5127</b>	<b>[APS Mode]</b>		
5-127-001	-	CTL*	[0 or 1 / <b>0</b> / 1 / step] 0: Not disabled 1: Disabled

<b>5162</b>	<b>[App. Switch Method]</b>		
5-162-001	-	CTL*	[0 or 1 / <b>0</b> / 1 / step] 0: Soft Key Set 1: Hard Key Set

<b>5167</b>	<b>[Fax Printing Mode at Optional Counter Off]</b>		
5-167-001	-	CTL*	[0 or 1 / <b>0</b> / 1 / step] 0: Automatic printing 1: No automatic printing

Main SP Tables-5 (Controller)

<b>5169</b>	<b>[CE Login]</b>		
5-169-001	-	CTL*	[0 or 1 / <b>0</b> / 1 / step] 0: Disabled 1: Enabled

<b>5188</b>	<b>[Copy NvVersion]</b>		
5-188-001	-	CTL*	[- / - / - / step]

<b>5191</b>	<b>[Mode Set]</b>		
5-191-001	Power Str Set	CTL*	[0 or 1 / <b>1</b> / 1 / step] 0: OFF 1: ON

<b>5212</b>	<b>[Page Numbering]</b>		
5-212-003	Duplex Printout Left/Right Position of Left/Right Facing	CTL*	[-1000 or 1000 / <b>0</b> / 0.01 mm/step]
5-212-004	Duplex Printout Top/Bottom Position of Left/Right Facing	CTL*	[-1000 or 1000 / <b>0</b> / 0.01 mm/step]
5-212-018	Duplex Printout Left/Right Position of Top/Bottom Facing	CTL*	[-1000 or 1000 / <b>0</b> / 0.01 mm/step]
5-212-019	Duplex Printout Top/Bottom Position of Top/Bottom Facing	CTL*	[-1000 or 1000 / <b>0</b> / 0.01 mm/step]

<b>5227</b>	<b>[Page Numbering]</b>		
5-227-201	Allow Page No. Entry	CTL*	[2 to 9 / <b>0</b> / 1 / step]
5-227-202	Zero Surplus Setting	CTL*	[0 or 1 / <b>0</b> / 1 / step]

<b>5302</b>	<b>[Set Time]</b>		
5-302-002	Time Difference	CTL*	[-1440 to 1440 / <b>NA: -300, EU: 60, KOR: 540, Other: 480</b> / 1 / step]

<b>5305</b>	<b>[Auto Off Set]</b>		
5-305-101	Auto Off Limit Set	CTL*	[0 or 1 / <b>0</b> / 1 / step] 0: Limitation off 1: Limitation on

<b>5307</b>	<b>[Daylight Saving Time]</b>		
5-307-001	Setting	CTL*	[0 or 1 / <b>NA/EU:0, Other:0</b> / 1 / step]
5-307-003	Rule Set(Start)	CTL*	[0 to 0xffffffff / <b>NA: 0x03200210</b> <b>EU: 0x03500010</b> <b>AA: 0x10500010</b> <b>Other: 0</b> / 1 / step]
5-307-004	Rule Set(End)	CTL*	[0 to 0xffffffff / <b>0</b> / 1 / step]

<b>5401</b>	<b>[Access Control]</b>		
5-401-103	Default Document ACL	CTL*	[0 to 3 / <b>0</b> / 1 / step] 0: Read Only 1: Edit 2: Edit/Delete 3: Full control
5-401-104	Authentication Time	CTL*	[0 to 255 / <b>0</b> / 1 sec / step]
5-401-160	Extend Certification	CTL*	[0 or 1 / <b>0</b> / 1 / step]

Main SP Tables-5 (Controller)

5-401-161	Extend Certification Detail	CTL*	[0 to 0xFF / 0 / 1 / step]
5-401-162	Extend Certification Detail	CTL*	[0 to 0xFF / 0 / 1 / step]
5-401-163	Extend Install State	CTL*	[0 to 0xFF / 0 / 1 / step]
5-401-200	SDK1 UniqueID	CTL*	[0 to 0xFFFFFFFF / 0 / 1 / step]
5-401-201	SDK1 Certification Method	CTL*	[0 to 0xFF / 0 / 1 / step]
5-401-210	SDK2 UniqueID	CTL*	[0 to 0xFFFFFFFF / 0 / 1 / step]
5-401-211	SDK2 Certification Method	CTL*	[0 to 0xFF / 0 / 1 / step]
5-401-220	SDK3 UniqueID	CTL*	[0 to 0xFFFFFFFF / 0 / 1 / step]
5-401-221	SDK3 Certification Method	CTL*	[0 to 0xFF / 0 / 1 / step]
5-401-230	SDK Certification Device	CTL*	[0 to 0xff / 0 / 1 / step]
5-401-240	Detail Option	CTL*	[0 to 0xff / 0 / 1 / step]

<b>5402</b>	<b>[Access Control]</b>		
5-402-101	SDKJ1 Limit Setting	CTL*	[0 to 0xFF / 0 / 1 / step]
5-402-102	SDKJ2 Limit Setting	CTL*	
5-402-103	SDKJ3 Limit Setting	CTL*	
5-402-104	SDKJ4 Limit Setting	CTL*	
5-402-105	SDKJ5 Limit Setting	CTL*	
5-402-106	SDKJ6 Limit Setting	CTL*	
5-402-107	SDKJ7 Limit Setting	CTL*	
5-402-108	SDKJ8 Limit Setting	CTL*	
5-402-109	SDKJ9 Limit Setting	CTL*	

5-402-110	SDKJ10 Limit Setting	CTL*	
5-402-111	SDKJ11 Limit Setting	CTL*	
5-402-112	SDKJ12 Limit Setting	CTL*	
5-402-113	SDKJ13 Limit Setting	CTL*	
5-402-114	SDKJ14 Limit Setting	CTL*	
5-402-115	SDKJ15 Limit Setting	CTL*	
5-402-116	SDKJ16 Limit Setting	CTL*	
5-402-117	SDKJ17 Limit Setting	CTL*	
5-402-118	SDKJ18 Limit Setting	CTL*	
5-402-119	SDKJ19 Limit Setting	CTL*	
5-402-120	SDKJ20 Limit Setting	CTL*	
5-402-121	SDKJ21 Limit Setting	CTL*	
5-402-122	SDKJ22 Limit Setting	CTL*	
5-402-123	SDKJ23 Limit Setting	CTL*	
5-402-124	SDKJ24 Limit Setting	CTL*	

Main SP Tables-5 (Controller)

5-402-125	SDKJ25 Limit Setting	CTL*	
5-402-126	SDKJ26 Limit Setting	CTL*	
5-402-127	SDKJ27 Limit Setting	CTL*	
5-402-128	SDKJ28 Limit Setting	CTL*	
5-402-129	SDKJ29 Limit Setting	CTL*	
5-402-130	SDKJ30 Limit Setting	CTL*	
5-402-141	SDKJ1 Product ID	CTL*	
5-402-142	SDKJ2 Product ID	CTL*	
5-402-143	SDKJ3 Product ID	CTL*	
5-402-144	SDKJ4 Product ID	CTL*	
5-402-145	SDKJ5 Product ID	CTL*	
5-402-146	SDKJ6 Product ID	CTL*	
5-402-147	SDKJ7 Product ID	CTL*	
5-402-148	SDKJ8 Product ID	CTL*	
5-402-149	SDKJ9 Product ID	CTL*	
5-402-150	SDKJ10 Product ID	CTL*	
5-402-151	SDKJ11 Product ID	CTL*	
5-402-152	SDKJ12 Product ID	CTL*	
5-402-153	SDKJ13 Product ID	CTL*	
5-402-154	SDKJ14 Product ID	CTL*	
5-402-155	SDKJ15 Product ID	CTL*	
5-402-156	SDKJ16 Product ID	CTL*	

5-402-157	SDKJ17 Product ID	CTL*	
5-402-158	SDKJ18 Product ID	CTL*	
5-402-159	SDKJ19 Product ID	CTL*	
5-402-160	SDKJ20 Product ID	CTL*	
5-402-161	SDKJ21 Product ID	CTL*	
5-402-162	SDKJ22 Product ID	CTL*	
5-402-163	SDKJ23 Product ID	CTL*	
5-402-164	SDKJ24 Product ID	CTL*	
5-402-165	SDKJ25 Product ID	CTL*	
5-402-166	SDKJ26 Product ID	CTL*	
5-402-167	SDKJ27 Product ID	CTL*	
5-402-168	SDKJ28 Product ID	CTL*	
5-402-169	SDKJ29 Product ID	CTL*	
5-402-170	SDKJ30 Product ID	CTL*	

<b>5404</b>	<b>[User Code Count Clear]</b>		
5-404-001	User Code Count Clear	CTL*	[- / - / - / step]

<b>5411</b>	<b>[LDAP-Certification]</b>		
5-411-004	Simplified Authentication	CTL*	[0 or 1 / 1 / 1 / step] 0: OFF 1: ON
5-411-005	Password Null Not Permit	CTL*	[0 or 1 / 1 / 1 / step] 0: Password NULL permitted. 1: Password NULL not permitted.
5-411-006	Detail Option	CTL*	[0 to 0xff / 0 / 1 / step] 0: Anonymous authentication OFF 1: Anonymous authentication ON

Main SP Tables-5 (Controller)

<b>5412</b>	<b>[Krb-Certification]</b>		
	-		
5-412-100	Encrypt Mode	CTL*	[0 to 0xFF / <b>0x1F</b> / 1 / step]

<b>5413</b>	<b>[Lockout Setting]</b>		
5-413-001	Lockout On/Off	CTL*	[0 or 1 / <b>0</b> / 1 / step] 0: OFF 1: ON
5-413-002	Lockout Threshold	CTL*	[1 to 10 / <b>5</b> / 1 / step]
5-413-003	Cancelation On/Off	CTL*	[0 or 1 / <b>0</b> / 1 / step] 0: OFF 1: ON
5-413-004	Cancelation Time	CTL*	[1 to 9999 / <b>60</b> / 1 min / step]

<b>5414</b>	<b>[Access Mitigation]</b>		
5-414-001	Mitigation On/Off	CTL*	[0 or 1 / <b>0</b> / 1 / step] 0: OFF 1: ON
5-414-002	Mitigation Time	CTL*	[0 to 60 / <b>15</b> / 1 min / step]

<b>5415</b>	<b>[Password Attack]</b>		
5-415-001	Permissible Number	CTL*	[0 to 100 / <b>30</b> / 1 / step]
5-415-002	Detect Time	CTL*	[0 to 10 / <b>5</b> / 1 / step]



<b>5416</b>	<b>[Access Information]</b>		
5-416-001	Access User Max Num	CTL*	[50 to 200 / <b>200</b> / 1 / step]
5-416-002	Access Password Max Num	CTL*	[50 to 200 / <b>200</b> / 1 / step]
5-416-003	Monitor Interval	CTL*	[1 to 10 / <b>3</b> / 1 / step]

<b>5417</b>	<b>[Access Attack]</b>		
5-417-001	Access Permissible Number	CTL*	[0 to 500 / <b>100</b> / 1 / step]
5-417-002	Attack Detect Time	CTL*	[10 to 30 / <b>10</b> / 1 sec / step]
5-417-003	Productivity Fall Wait	CTL*	[0 to 9 / <b>3</b> / 1 sec / step]
5-417-004	Attack Max Num	CTL*	[50 to 200 / <b>200</b> / 1 / step]

<b>5420</b>	<b>[User Authentication]</b>		
5-420-001	Copy	CTL*	[0 or 1 / <b>0</b> / 1 / step] 0: ON, 1: OFF
5-420-011	Document Server	CTL*	[0 or 1 / <b>0</b> / 1 / step] 0: ON, 1: OFF
5-420-021	Fax	CTL*	[0 or 1 / <b>0</b> / 1 / step] 0: ON, 1: OFF
5-420-031	Scanner	CTL*	[0 or 1 / <b>0</b> / 1 / step] 0: ON, 1: OFF
5-420-041	Printer	CTL*	[0 or 1 / <b>0</b> / 1 / step] 0: ON, 1: OFF
5-420-051	SDK1	CTL*	[0 or 1 / <b>0</b> / 1 / step] 0: ON, 1: OFF

Main SP Tables-5 (Controller)

5-420-061	SDK 2	CTL*	[0 or 1 / 0 / 1 / step] 0: ON, 1: OFF
5-420-071	SDK 3	CTL*	[0 or 1 / 0 / 1 / step] 0: ON, 1: OFF
5-420-081	Browser	CTL*	[0 or 1 / 0 / 1 / step] 0: ON, 1: OFF

<b>5430</b>	<b>[Auth Dialog Message Change]</b>		
5-430-001	Message Change On/Off	CTL*	[0 or 1 / 0 / 1 / step] 0: Function OFF 1: Function ON
5-430-002	Message Text Download	CTL*	[- / - / - / step]
5-430-003	Message Text ID	CTL*	[- / - / - / step]

<b>5431</b>	<b>[External Auth User Preset]</b>		
5-431-010	Tag	CTL*	[0 or 1 / 1 / 1 / step] 0: Not permit, 1: Permit
5-431-011	Entry	CTL*	[0 or 1 / 1 / 1 / step] 0: Not permit, 1: Permit
5-431-012	Group	CTL*	[0 or 1 / 1 / 1 / step] 0: Not permit, 1: Permit
5-431-020	Mail	CTL*	[0 or 1 / 1 / 1 / step] 0: Not permit, 1: Permit
5-431-030	FAX	CTL*	[0 or 1 / 1 / 1 / step] 0: Not permit, 1: Permit
5-431-031	FaxSub	CTL*	[0 or 1 / 1 / 1 / step] 0: Not permit, 1: Permit
5-431-032	Folder	CTL*	[0 or 1 / 1 / 1 / step] 0: Not permit, 1: Permit

5-431-033	Protect Code	CTL*	[0 or 1 / 1 / 1 / step] 0: Not permit, 1: Permit
5-431-034	Smtpt Auth	CTL*	[0 or 1 / 1 / 1 / step] 0: Not permit, 1: Permit
5-431-035	Ldap Auth	CTL*	[0 or 1 / 1 / 1 / step] 0: Not permit, 1: Permit
5-431-036	Smb Ftp Fldr Auth	CTL*	[0 or 1 / 1 / 1 / step] 0: Not permit, 1: Permit
5-431-037	Acnt Acl	CTL*	[0 or 1 / 1 / 1 / step] 0: Not permit, 1: Permit
5-431-038	Document Acl	CTL*	[0 or 1 / 1 / 1 / step] 0: Not permit, 1: Permit
5-431-040	Cert Crypt	CTL*	[0 or 1 / 0 / 1 / step] 0: Not permit, 1: Permit
5-431-050	User Limit Count	CTL*	[0 or 1 / 1 / 1 / step] 0: Not permit, 1: Permit

<b>5481</b>	<b>[Authentication Error Code]</b>		
5-481-001	System Log Disp	CTL*	[0 or 1 / 0 / 1 / step] 0: Display OFF, 1: Display ON
5-481-002	Panel Disp	CTL*	[0 or 1 / 1 / 1 / step] 0: Display OFF, 1: Display ON

<b>5490</b>	<b>[MF KeyCard (Japan only)]</b>		
5-490-001	Job Permit Setting	CTL*	[0 or 1 / 0 / 1 / step] 0: Disable, 1: Enable

Main SP Tables-5 (Controller)

<b>5491</b>	<b>[Optional Counter]</b>		
5-491-001	Detail Option	CTL*	[0 to 0xff / <b>0</b> / 1 / step] 0: Forced Job Canceling OFF 1: Forced Job Canceling ON

<b>5501</b>	<b>[PM Alarm]</b>		
5-501-001	PM Alarm Level	CTL*	[0 to 9999 / <b>0</b> / 1 / step]
5-501-002	Original Count Alarm	CTL*	[0 or 1 / <b>0</b> / 1 / step]

<b>5504</b>	<b>[Jam Alarm]</b>		
5-504-001	Level Setting	CTL*	[0 to 3 / <b>3</b> / 1 / step] 0: Zero (Off) 1: Low (2.5K jams) 2: Medium (3K jams) 3: High (6K jams)
5-504-002	Threshold	CTL*	[1 to 99 / <b>10</b> / 1 / step]

<b>5505</b>	<b>[Error Alarm]</b>		
5-505-001	Level Setting	CTL*	[0 to 255 / <b>2</b> / 1 / step]
5-505-002	Threshold	CTL*	[1 to 99 / * / 1 / step]

<b>5507</b>	<b>[Supply/CC Alarm]</b>		
5-507-001	Paper Supply Alarm	CTL*	[0 or 1 / <b>0</b> / 1 / step] 0: OFF, 1: ON
5-507-003	Toner Supply Alarm	CTL*	[0 or 1 / <b>0</b> / 1 / step] 0: OFF, 1: ON
5-507-080	Toner Call Timing	CTL*	[0 or 1 / <b>1</b> / 1 / step] 0: At replacement 1: AtLessThanThresh

5-507-081	Toner Call Threshold	CTL*	[10 to 90 / <b>10</b> / 10 % / step]
5-507-128	Interval: Others	CTL*	[250 to 10000 / <b>1000</b> / 1 / step]
5-507-132	Interval:A3	CTL*	[250 to 10000 / <b>1000</b> / 1 / step]
5-507-133	Interval:A4	CTL*	[250 to 10000 / <b>1000</b> / 1 / step]
5-507-134	Interval:A5	CTL*	[250 to 10000 / <b>1000</b> / 1 / step]
5-507-141	Interval:B4	CTL*	[250 to 10000 / <b>1000</b> / 1 / step]
5-507-142	Interval:B5	CTL*	[250 to 10000 / <b>1000</b> / 1 / step]
5-507-160	Interval:DLT	CTL*	[250 to 10000 / <b>1000</b> / 1 / step]
5-507-164	Interval:LG	CTL*	[250 to 10000 / <b>1000</b> / 1 / step]
5-507-166	Interval:LT	CTL*	[250 to 10000 / <b>1000</b> / 1 / step]
5-507-172	Interval:HLT	CTL*	[250 to 10000 / <b>1000</b> / 1 / step]

<b>5508</b>	<b>[CC Call]</b>		
5-508-001	Jam Remains	CTL*	[0 or 1 / <b>1</b> / 1 / step] 0: Disable, 1: Enable
5-508-002	Continuous Jams	CTL*	[0 or 1 / <b>1</b> / 1 / step] 0: Disable, 1: Enable
5-508-003	Continuous Door Open	CTL*	[0 or 1 / <b>1</b> / 1 / step] 0: Disable, 1: Enable
5-508-011	Jam Detection: Time Length	CTL*	[3 to 30 / <b>10</b> / 1 / step]
5-508-012	Jam Detection: Continuous Count	CTL*	[2 to 10 / <b>5</b> / 1 / step]
5-508-013	Door Open: Time Length	CTL*	[3 to 30 / <b>10</b> / 1 / step]

Main SP Tables-5 (Controller)

<b>5515</b>	<b>[SC/Alarm Setting]</b>		
5-515-001	SC Call	CTL*	[0 or 1 / 1 / 1 / step] 0: Off, 1: On
5-515-002	Service Parts Near End Call	CTL*	[0 or 1 / 1 / 1 / step] 0: Off, 1: On
5-515-003	Service Parts End Call	CTL*	[0 or 1 / 1 / 1 / step] 0: Off, 1: On
5-515-004	User Call	CTL*	[0 or 1 / 1 / 1 / step] 0: Off, 1: On
5-515-006	Communication Test Call	CTL*	[0 or 1 / 1 / 1 / step] 0: Off, 1: On
5-515-007	Machine Information Notice	CTL*	[0 or 1 / 1 / 1 / step] 0: Off, 1: On
5-515-008	Alarm Notice	CTL*	[0 or 1 / 1 / 1 / step] 0: Off, 1: On
5-515-010	Supply Automatic Ordering Call	CTL*	[0 or 1 / 1 / 1 / step] 0: Off, 1: On
5-515-011	Supply Management Report Call	CTL*	[0 or 1 / 1 / 1 / step] 0: Off, 1: On
5-515-012	Jam/Door Open Call	CTL*	[0 or 1 / 1 / 1 / step] 0: Off, 1: On
5-515-050	Timeout:Manual Call	CTL*	[1 to 255 / 5 / 1 min / step]
5-515-051	Timeout:Other Call	CTL*	[1 to 255 / 10 / 1 min / step]

<b>5517</b>	<b>[Get Machine Information]</b>		
5-517-031	Get SMC Info: Retry Interval	CTL*	[0 to 255 / 10 / 1 min / step]

<b>5713</b>	<b>[Service Blanch Information]</b>		
5-713-001	Service Blanch Information Code	CTL*	[7digit / - / - / step]

<b>5728</b>	<b>[Network Setting]</b>		
5-728-001	NAT Machine Port1	CTL*	[1 to 65535 / <b>49101</b> / 1 / step]
5-728-002	NAT UI Port1	CTL*	[1 to 65535 / <b>55101</b> / 1 / step]
5-728-003	NAT Machine Port2	CTL*	[1 to 65535 / <b>49102</b> / 1 / step]
5-728-004	NAT UI Port2	CTL*	[1 to 65535 / <b>55102</b> / 1 / step]
5-728-005	NAT Machine Port3	CTL*	[1 to 65535 / <b>49103</b> / 1 / step]
5-728-006	NAT UI Port3	CTL*	[1 to 65535 / <b>55103</b> / 1 / step]
5-728-007	NAT Machine Port4	CTL*	[1 to 65535 / <b>49104</b> / 1 / step]
5-728-008	NAT UI Port4	CTL*	[1 to 65535 / <b>55104</b> / 1 / step]
5-728-009	NAT Machine Port5	CTL*	[1 to 65535 / <b>49105</b> / 1 / step]
5-728-010	NAT UI Port5	CTL*	[1 to 65535 / <b>55105</b> / 1 / step]
5-728-011	NAT Machine Port6	CTL*	[1 to 65535 / <b>49106</b> / 1 / step]
5-728-012	NAT UI Port6	CTL*	[1 to 65535 / <b>55106</b> / 1 / step]
5-728-013	NAT Machine Port7	CTL*	[1 to 65535 / <b>49107</b> / 1 / step]
5-728-014	NAT UI Port7	CTL*	[1 to 65535 / <b>55107</b> / 1 / step]
5-728-015	NAT Machine Port8	CTL*	[1 to 65535 / <b>49108</b> / 1 / step]
5-728-016	NAT UI Port8	CTL*	[1 to 65535 / <b>55108</b> / 1 / step]
5-728-017	NAT Machine Port9	CTL*	[1 to 65535 / <b>49109</b> / 1 / step]
5-728-018	NAT UI Port9	CTL*	[1 to 65535 / <b>55109</b> / 1 / step]
5-728-019	NAT Machine Port10	CTL*	[1 to 65535 / <b>49110</b> / 1 / step]
5-728-020	NAT UI Port10	CTL*	[1 to 65535 / <b>55110</b> / 1 / step]

Main SP Tables-5 (Controller)

<b>5730</b>	<b>[Extended Function Setting]</b>		
5-730-001	Java™ Platform setting	CTL*	[0 or 1 / <b>0</b> / 1 / step] 0: Disable 1: Enable
5-730-010	Expiration Prior Alarm Set	CTL*	[0 to 999 / <b>20</b> / 1 days / step]

<b>5731</b>	<b>[Counter Effect]</b>		
5-731-001	Change Mk1 Cnt(Paper->Combine)	CTL*	[0 or 1 / <b>0</b> / 1 / step] 0: Disable 1: Enable

<b>5734</b>	<b>[PDF Setting]</b>		
5-734-001	PDF/A Fixed	CTL*	[0 or 1 / <b>0</b> / 1 / step]

<b>5745</b>	<b>[Deemed Power Consumption]</b>		
5-745-211	Controller Standby	CTL*	[0 to 9999 / <b>0</b> / 1 / step]
5-745-212	STR	CTL*	[0 to 9999 / <b>0</b> / 1 / step]
5-745-213	Main Power Off	CTL*	[0 to 9999 / <b>0</b> / 1 / step]
5-745-214	Scanning and Printing	CTL*	[0 to 9999 / <b>0</b> / 1 / step]
5-745-215	Printing	CTL*	[0 to 9999 / <b>0</b> / 1 / step]
5-745-216	Scanning	CTL*	[0 to 9999 / <b>0</b> / 1 / step]
5-745-217	Engine Standby	CTL*	[0 to 9999 / <b>0</b> / 1 / step]
5-745-218	Low Power Consumption	CTL*	[0 to 9999 / <b>0</b> / 1 / step]
5-745-219	Silent condition	CTL*	[0 to 9999 / <b>0</b> / 1 / step]
5-745-220	Heater Off	CTL*	[0 to 9999 / <b>0</b> / 1 / step]



<b>5748</b>	<b>[OpePanel Setting]</b>		
5-748-101	Op Type Action Setting	CTL*	[0 to 255/ <b>0</b> / 1 / step]

<b>5749</b>	<b>[Import/Export]</b>		
5-749-001	Export	CTL	[EXECUTE]
5-749-101	Import	CTL	[EXECUTE]

<b>5751</b>	<b>[Key Event Encryption Setting]</b>		
5-751-001	Password	CTL*	[0 to 255/ <b>0</b> / 1 / step]

<b>5752</b>	<b>[Copy:WebAPI Setting]</b>		
5-752-001	Copy:FlairAPI Setting	CTL*	<p>[0 to 255 / <b>0</b> / 1 / step]</p> <p>Bit0: FlairAPI server start up 0:Off, 1: On</p> <p>Bit1: Access permission from FlairAPI external device 0: Disabled, 1: Enabled</p> <p>Bit2: Switching dedicated IPv6 0: IPv6 only, 1: IPv4 priority</p> <p>Bit3:Remote UI function 0: Disabled, 1: Enabled</p> <p>Bit4 to Bit7: Not used</p>

<b>5755</b>	<b>[Display Setting]</b>		
5-755-001	Disp Administrator Password Change Scrn	CTL*	[- / - / - / step]
5-755-002	Hide Administrator Password Change Scrn	CTL*	[- / - / - / step]

<b>5759</b>	<b>[Machine Limit Count]</b>		
5-759-001	Machine Limit Count Setting	CTL*	[0 or 1 / 0 / 1 / step]
5-759-051	Limit Count	CTL*	[0 to 999999999 / 0 / 1 / step]

<b>5761</b>	<b>[SmartOperationPanel Setting]</b>		
5-761-001	Restore the default Home screen	CTL*	[0 to 255 / 0 / 1 / step]

<b>5801</b>	<b>[Memory Clear]</b>		
5-801-001	All Clear	CTL	[- / - / - / step]
5-801-003	SCS	CTL	[- / - / - / step]
5-801-004	IMH	CTL	[- / - / - / step]
5-801-005	MCS	CTL	[- / - / - / step]
5-801-006	Copier Application	CTL	[- / - / - / step]
5-801-007	Fax Application	CTL	[- / - / - / step]
5-801-008	Printer Application	CTL	[- / - / - / step]
5-801-009	Scanner Application	CTL	[- / - / - / step]

5-801-010	Web Service	CTL	[- / - / - / step]
5-801-011	NCS	CTL	[- / - / - / step]
5-801-012	R-FAX	CTL	[- / - / - / step]
5-801-014	Clear DCS Setting	CTL	[- / - / - / step]
5-801-015	Clear UCS Setting	CTL	[- / - / - / step]
5-801-016	MIRS Setting	CTL	[- / - / - / step]
5-801-017	CCS	CTL	[- / - / - / step]
5-801-018	SRM Memory Clr	CTL	[- / - / - / step]
5-801-019	LCS	CTL	[- / - / - / step]
5-801-020	WebUapl	CTL	[- / - / - / step]
5-801-021	ECS	CTL	[- / - / - / step]
5-801-023	AICS	CTL	[- / - / - / step]
5-801-025	websys	CTL	[- / - / - / step]
5-801-026	PLN	CTL	[- / - / - / step]
5-801-027	SAS	CTL	[- / - / - / step]
5-801-028	Rest WebService	CTL	[- / - / - / step]

<b>5812</b>	<b>[Service Tel. No. Setting]</b>		
5-812-001	Service	CTL*	[- / - / - / step]
5-812-002	Facsimile	CTL*	[- / - / - / step]
5-812-003	Supply	CTL*	[- / - / - / step]
5-812-004	Operation	CTL*	[- / - / - / step]

## Main SP Tables-5 (Controller)

<b>5816</b>	<b>[Remote Service]</b>		
5-816-001	I/F Setting	CTL*	[0 to 2 / <b>2</b> / 1 / step]
5-816-002	CE Call	CTL*	[0 or 1 / <b>0</b> / 1 / step]
5-816-003	Function Flag	CTL*	[0 or 1 / <b>0</b> / 1 / step]
5-816-007	SSL Disable	CTL*	[0 or 1 / <b>0</b> / 1 / step]
5-816-008	RCG Connect Timeout	CTL*	[0 to 90 / <b>30</b> / 1 sec / step]
5-816-009	RCG Write Timeout	CTL*	[0 to 100 / <b>60</b> / 1 sec / step]
5-816-010	RCG Read Timeout	CTL*	[0 to 100 / <b>60</b> / 1 sec / step]
5-816-011	Port 80 Enable	CTL*	[0 or 1 / <b>0</b> / 1 / step]
5-816-013	RFU Timing	CTL*	[0 or 1 / <b>1</b> / 1 / step]
5-816-014	RCG Error Cause	CTL	[0 to 2 / <b>0</b> / 1 / step]
5-816-063	Proxy Host	CTL	[- / <b>0</b> / - / step]
5-816-064	Proxy PortNumber	CTL	[0xffff to 0 / <b>0</b> / 1 / step]
5-816-065	Proxy User Name	CTL	[- / <b>0</b> / - / step]
5-816-066	Proxy Password	CTL	[- / <b>0</b> / - / step]
5-816-102	CERT:Encrypt Level	CTL*	[1 to 2 / <b>1</b> / 1 / step]
5-816-103	Client Communication Method	CTL*	[0 to 3 / <b>0</b> / 1 / step]
5-816-104	Client Communication Limit	CTL*	[1 to 7 / <b>7</b> / 1 / step]

5-816-115	Network Information Waiting timer	CTL*	[5 to 255 / <b>5</b> / 1 sec / step]
5-816-190	3G DongleID	CTL*	[- / - / - / step]
5-816-209	Instl Clear	CTL	[0 or 1 / <b>0</b> / 1 / step]

<b>5821</b>	<b>[Remote Service RCG Setting]</b>		
5-821-002	RCG IPv4 Address	CTL*	[00000000h to FFFFFFFFh / <b>00000000h</b> / 1 / step]
5-821-003	RCG Port	CTL*	[0 to 65535 / <b>443</b> / 1 / step]
5-821-004	RCG IPv4 URL Path	CTL*	[- / - / - / step]
5-821-005	RCG IPv6 Address	CTL*	[- / - / - / step]
5-821-006	RCG IPv6 URL Path	CTL*	[- / - / - / step]
5-821-007	RCG Host Name	CTL*	[- / - / - / step]
5-821-008	RCG Host URL Path	CTL*	[- / - / - / step]

<b>5824</b>	<b>[NV-RAM Data Upload]</b>		
5-824-001	-	CTL	[- / - / - / step]

<b>5825</b>	<b>[NV-RAM Data Download]</b>		
5-825-001	-	CTL	[- / - / - / step]

<b>5828</b>	<b>[Network Setting]</b>		
5-828-050	1284 Compatibility (Centro)	CTL*	[0 or 1 / <b>1</b> / 1 / step]
5-828-052	ECP(Centro)	CTL*	[0 or 1 / <b>1</b> / 1 / step]

Main SP Tables-5 (Controller)

5-828-065	Job Spooling	CTL*	[0 or 1 / <b>0</b> / - / step] 0: Disabled, 1: Enabled
5-828-066	Job Spooling Clear: Start Time	CTL*	[0 or 1 / <b>1</b> / - / step] 0: ON (Data is cleared), 1: OFF (Automatically printed)
5-828-069	Job Spooling (Protocol)	CTL*	[- / <b>0x7f : All Active</b> / - / step] 0: Validates, 1: Invalidates bit0: LPR, bit1: FTP bit2: IPP, bit3: SMB bit4: BMLinkS, bit5: DIPRINT bit6: sftp, bit7: (Reserved)
5-828-087	Protocol usage	CTL*	[0x00000000 to 0xffffffff / <b>0x00000000</b> / 1 / step] 0: Off (Not used the network with the protocol.) 1: On (Used the network with the protocol once or more.) bit0: IPsec, bit1: IPv6, bit2: IEEE 802. 1X, bit3: Wireless LAN, bit4: Security mode level setting, bit5: Appletalk, bit6: DHCP, bit7: DHCPv6, bit8: telnet, bit9: SSL, bit10: HTTPS, bit11: BMLinkS printing, bit12: diprint printing, bit13: LPR printing, bit14: ftp printing, bit15: rsh printing, bit16: SMB printing, bit17: WSD-Printer, bit18: WSD-Scanner, bit19: Scan to SMB, bit20: Scan to NCP, bit21: Reserve, bit22: Bluetooth, bit23: IEEE 1284, bit24: USB printing, bit25: Dynamic DNS, bit26: Netware printing, bit27: LLTD, bit28: IPP printing, bit29: IPP printing (SSL), bit30: ssh, bit31: sftp

5-828-090	TELNET (0: OFF 1: ON)	CTL*	[0 or 1 / 1 / 1 / step] 0: Disable, 1: Enable
5-828-091	Web (0: OFF 1: ON)	CTL*	[0 or 1 / 1 / 1 / step] 0: Disable, 1: Enable
5-828-145	Active IPv6 Link Local Address	CTL	[000000000000000000 000000000000000000h to FFFFFFFFFFFFFFFF FFFFFFFFFFFFFFFF80h / <b>0000000000000000</b> <b>000000000000000040h</b> <b>(0000:0000:0000:0000:</b> <b>0000:0000:0000:0000 / 40) / - / step]</b>
5-828-147	SettingActive IPv6 Stateless Address 1	CTL	[000000000000000000 000000000000000000h to FFFFFFFFFFFFFFFF FFFFFFFFFFFFFFFF80h / <b>0000000000000000</b> <b>000000000000000040h</b> <b>(0000:0000:0000:0000:</b> <b>0000:0000:0000:0000 / 40) / - / step]</b>
5-828-149	SettingActive IPv6 Stateless Address 2	CTL	[000000000000000000 000000000000000000h to FFFFFFFFFFFFFFFF FFFFFFFFFFFFFFFF80h / <b>0000000000000000</b> <b>000000000000000040h</b> <b>(0000:0000:0000:0000:</b> <b>0000:0000:0000:0000 / 40) / - / step]</b>
5-828-151	Active IPv6 Stateless Address 3	CTL	[000000000000000000 000000000000000000h to FFFFFFFFFFFFFFFF FFFFFFFFFFFFFFFF80h / <b>0000000000000000</b> <b>000000000000000040h</b> <b>(0000:0000:0000:0000:</b> <b>0000:0000:0000:0000 / 40) / - / step]</b>

Main SP Tables-5 (Controller)

5-828-153	Active IPv6 Stateless Address 4	CTL	[00000000000000000000 000000000000000000h to FFFFFFFFFFFFFFFF FFFFFFFFFFFFFFFF80h / <b>0000000000000000</b> <b>000000000000000040h</b> <b>(0000:0000:0000:0000:</b> <b>0000:0000:0000:0000 / 40) / - / step]</b>
5-828-155	Active IPv6 Stateless Address 5	CTL	[00000000000000000000 000000000000000000h to FFFFFFFFFFFFFFFF FFFFFFFFFFFFFFFF80h / <b>0000000000000000</b> <b>000000000000000040h</b> <b>(0000:0000:0000:0000:</b> <b>0000:0000:0000:0000 / 40) / - / step]</b>
5-828-156	IPv6 Manual Address	CTL*	[00000000000000000000 000000000000000000h to FFFFFFFFFFFFFFFF FFFFFFFFFFFFFFFF80h / <b>0000000000000000</b> <b>000000000000000040h</b> <b>(0000:0000:0000:0000:</b> <b>0000:0000:0000:0000 / 40) / - / step]</b>
5-828-158	IPv6 Gateway Address	CTL*	[00000000000000000000 000000000000000000h to FFFFFFFFFFFFFFFF FFFFFFFFFFFFFFFFh / <b>0000000000000000</b> <b>000000000000000040h</b> <b>(0000:0000:0000:0000:</b> <b>0000:0000:0000:0000) / - / step]</b>
5-828-161	IPv6 Stateless Auto Setting	CTL*	[0 or 1 / 1 / 1 / step]
5-828-219	IPsec Aggressive Mode Setting	CTL*	[0 or 1 / 0 / 1 / step]



5-828-236	Web Item visible	CTL*	[0x0000 to 0xffff / <b>0xffff</b> / - / step] bit0: Net RICOH bit1: Consumable Supplier bit2-15: Reserved (all)
5-828-237	Web shopping link visible	CTL*	[0 or 1 / <b>1</b> / - / step]
5-828-238	Web supplies Link visible	CTL*	[0 or 1 / <b>1</b> / <b>1</b> / step]
5-828-239	Web Link1 Name	CTL*	[31 characters / <b>URL1</b> / - / step]
5-828-240	Web Link1 URL	CTL*	[127 characters / <b>NULL</b> / - / step]
5-828-241	Web Link1 visible	CTL*	[0 or 1 / <b>1</b> / - / step]
5-828-242	Web Link2 Name	CTL*	[31 characters / <b>URL2</b> / - / step]
5-828-243	Web Link2 URL	CTL*	[127 characters / <b>NULL</b> / - / step]
5-828-244	Web Link2 visible	CTL*	[0 or 1 / <b>1</b> / - / step]
5-828-249	DHCPv6 DUID	CTL	[00000000000000000000000000000000h to FFFFFFFFFFFFFFFFFFFFFFFFFFFFFFFFh / <b>00000000000000000000000000000000h</b> / - / step]

<b>5832</b>	<b>[HDD Formatting]</b>		
5-832-001	HDD Formatting (ALL)	CTL	[- / - / - / step]
5-832-002	HDD Formatting (IMH)	CTL	[- / - / - / step]
5-832-003	HDD Formatting (Thumbnail/OCR)	CTL	[- / - / - / step]
5-832-004	HDD Formatting (Job Log)	CTL	[- / - / - / step]
5-832-005	HDD Formatting (Printer Fonts)	CTL	[- / - / - / step]

Main SP Tables-5 (Controller)

5-832-006	HDD Formatting (User Info)	CTL	[- / - / - / step]
5-832-007	Mail RX Data	CTL	[- / - / - / step]
5-832-008	Mail TX Data	CTL	[- / - / - / step]
5-832-009	HDD Formatting (Data for a Design)	CTL	[- / - / - / step]
5-832-010	HDD Formatting (Log)	CTL	[- / - / - / step]
5-832-011	HDD Formatting (Ridoc I/F)	CTL	[- / - / - / step]
5-832-012	HDD Formatting (Thumbnail)	CTL	[- / - / - / step]

<b>5840</b>	<b>[IEEE 802.11]</b>		
5-840-011	WEP key Select	CTL*	[00 to 11 / <b>00</b> / - / step]
5-840-045	WPA Debug Lvl	CTL*	[1 to 3 / <b>3</b> / 1 / step] 1: Info, 2: warning, 3: error
5-840-046	11w	CTL*	[0 to 2 / <b>0</b> / 1 / step]
5-840-047	PSK Set Type	CTL*	[0 or 1 / <b>0</b> / 1 / step]

<b>5841</b>	<b>[Supply Name Setting]</b>		
5-841-001	Toner Name Setting:Black	CTL*	[- / - / - / step]

<b>5842</b>	<b>[GWWS Analysis]</b>		
5-842-001	Setting 1	CTL*	[8bit / <b>00000000</b> / - / step]
5-842-002	Setting 2	CTL*	[8bit / <b>00000000</b> / - / step]

<b>5844</b>	<b>[USB]</b>		
5-844-001	Transfer Rate	CTL*	[0x01 to 0x04 / <b>0x04</b> / - / step] 0001: Full speed 0004: Auto Change
5-844-005	Fixed USB Port	CTL*	[0 to 2 / <b>0</b> / 1 / step]
5-844-006	PnP Model Name	CTL*	[- / " <b>Laser Printer</b> " / - / step]
5-844-007	PnP Serial Number	CTL*	[- / - / - / step]
5-844-008	Mac Supply Level	CTL*	[0 or 1 / <b>1</b> / - / step]
5-844-100	Notify Unsupport	CTL*	[0x00 to 0x01 / <b>0x01</b> / 1 / step]

<b>5845</b>	<b>[Delivery Server Setting]</b>		
5-845-001	FTP Port No.	CTL*	[1 to 65535 / <b>3670</b> / 1 / step]
5-845-002	IP Address (Primary)	CTL*	[000.000.000.000 to 255.255.255.255 / <b>000.000.000.000</b> / 1 / step]
5-845-006	Delivery Error Display Time	CTL*	[0 to 999 / <b>300</b> / 1 sec / step]
5-845-008	IP Address (Secondary)	CTL*	[000.000.000.000 to 255.255.255.255 / <b>000.000.000.000</b> / 1 / step]
5-845-009	Delivery Server Model	CTL*	[0 to 4 / <b>0</b> / 1 / step] 0: Unknown 1: SG1 Provided 2: SG1 Package 3: SG2 Provided 4: SG2 Package
5-845-010	Delivery Svr. Capability	CTL*	[0 to 255 / <b>0</b> / 1 / step]
5-845-011	Delivery Svr Capability (Ext)	CTL*	[0 to 255 / <b>0</b> / multiples of 2 / step]
5-845-022	Rapid Sending Control	CTL*	[0 or 1 / <b>1</b> / 1 / step]

## Main SP Tables-5 (Controller)

<b>5846</b>	<b>[UCS Setting]</b>		
5-846-001	Machine ID (for Delivery Server)	CTL*	[- / - / - / step]
5-846-002	Machine ID Clear (for Delivery Server)	CTL*	[- / - / - / step]
5-846-003	Maximum Entries	CTL*	[2000 to 20000 / <b>2000</b> / 1 / step]
5-846-006	Delivery Server Retry Timer	CTL*	[0 to 255 / <b>0</b> / 1 / step]
5-846-007	Delivery Server Retry Times	CTL*	[0 to 255 / <b>0</b> / 1 / step]
5-846-008	Delivery Server Maximum Entries	CTL*	[2000 to 20000 / <b>2000</b> / 1 / step]
5-846-010	LDAP Search Timeout	CTL*	[1 to 255 / <b>60</b> / 1 / step]
5-846-020	WSD Maximum Entries	CTL*	[50 to 250 / <b>250</b> / 1 / step]
5-846-021	Folder Auth Change	CTL*	[0 or 1 / <b>0</b> / 1 / step]
5-846-040	Addr Book Migration(USB->HDD)	CTL	[- / - / - / step]
5-846-041	Fill Addr Acl Info	CTL	[- / - / - / step]
5-846-043	Addr Book Media	CTL *	[0 to 30 / <b>0</b> / 1 / step] 0: Unconfirmed 1: SD Slot 1 2: SD Slot 2 4: USB Flash ROM 10: SD Slot 10 20: HDD 30: Nothing
5-846-047	Initialize Local Addr Book	CTL	[- / - / - / step]

5-846-048	Initialize Delivery Addr Book	CTL	[- / - / - / step]
5-846-049	Initialize LDAP Addr Book	CTL	[- / - / - / step]
5-846-050	Initialize All Addr Book	CTL	[- / - / - / step]
5-846-051	Backup All Addr Book	CTL	[- / - / - / step]
5-846-052	Restore All Addr Book	CTL	[- / - / - / - / step]
5-846-053	Clear Backup Info	CTL	[- / - / - / step]
5-846-060	Search option	CTL*	[0x00 to 0xff / <b>0x0f</b> / 1 / step]
5-846-062	Complexity option 1	CTL*	[0 to 32 / <b>0</b> / 1 / step]
5-846-063	Complexity option 2	CTL*	[0 to 32 / <b>0</b> / 1 / step]
5-846-064	Complexity option 3	CTL*	[0 to 32 / <b>0</b> / 1 / step]
5-846-065	Complexity option 4	CTL*	[0 to 32 / <b>0</b> / 1 / step]
5-846-091	FTP Auth Port Setting	CTL*	[0 to 65535 / <b>3671</b> / 1 / step]
5-846-094	Encryption Stat	CTL*	[0 to 255 / - / 1 / step]

<b>5848</b>	<b>[Web Service]</b>		
5-848-002	Access Ctrl: Repository (only Lower 4 bits)	CTL*	[4bit / <b>0010</b> / bit switch / step]
5-848-003	Access Control: Doc. Svr. Print (Lower 4 bits)	CTL*	[4bit / <b>0000</b> / bit switch / step]
5-848-004	Access Control: udirectory (Lower 4 bits)	CTL*	[4bit / <b>0000</b> / bit switch / step]
5-848-007	Access Ctrl: Comm. Log Fax (Lower 4 bits)	CTL*	[4bit / <b>0000</b> / bit switch / step]

Main SP Tables-5 (Controller)

5-848-009	Access Ctrl: Job Ctrl (Lower 4 bits)	CTL*	[4bit / <b>0000</b> / bit switch / step]
5-848-011	Access Ctrl: Devicemanagement (Lower 4bits)	CTL*	[4bit / <b>0000</b> / bit switch / step]
5-848-021	Access Ctrl: Delivery (Lower 4 bits)	CTL*	[[4bit / <b>0000</b> / bit switch / step]
5-848-022	Access Ctrl: administration (Lower 4bits)	CTL*	[4bit / <b>0000</b> / bit switch / step]
5-848-024	Access Ctrl: Log Service (Lower 4bits)	CTL*	[4bit / <b>0000</b> / bit switch / step]
5-848-025	Access Ctrl: Rest WebService (Lower 4bits)	CTL*	[4bit / <b>0000</b> / bit switch / step]
5-848-099	Repository: Download Image Setting	CTL*	[0000 to 0111 / <b>0000</b> / 1 / step]
5-848-100	Repository: Download Image Max. Size	CTL*	[1 to 2048 / <b>2048</b> / 1 MByte / step]
5-848-150	Log Operation Mode	CTL*	[0 to 9 / <b>0</b> / 1 / step]

<b>5848</b>	<b>[LogTrans]</b>		
5-848-217	Setting: Timing	CTL*	[0 to 2 / <b>0</b> / 1 / step]

<b>5849</b>	<b>[Installation Date]</b>		
5-849-001	Display	CTL*	[- / - / - / step]
5-849-002	Switch to Print	CTL*	[0 or 1 / <b>0</b> / 1 / step]
5-849-003	Setup Count	CTL*	[0 to 99999999 / <b>0</b> / 1 / step]

<b>5851</b>	<b>[Bluetooth]</b>		
5-851-001	mode	CTL*	[0 or 1 / <b>0</b> / - / step] 0: Public, 1:Private

<b>5856</b>	<b>[Remote ROM Update]</b>		
5-856-002	Local Port	CTL	[0 or 1 / <b>0</b> / 1 / step] 0: Disable, 1: Enable

<b>5858</b>	<b>[Save Machine Info]</b>		
5-858-001	0:OFF 1:ON	CTL*	[0 or 1 / <b>1</b> / 1 / step]
5-858-002	Target(0:HDD 1:SD)	CTL*	[0 or 1 / <b>0</b> / 1 / step]
5-858-003	Make LogTrace Dir	CTL*	[- / - / - / step]
5-858-101	Start Date	CTL*	[0 to 20371212 / <b>0</b> / 1 / step]
5-858-102	Days of Tracing	CTL*	[1 to 180 / <b>2</b> / 1 day / step]
5-858-103	Acquire Fax Address(0:OFF 1:ON)	CTL*	[0 or 1 / <b>0</b> / 1 / step]
5-858-111	Acquire All Info & Logs	CTL*	[- / - / - / step]
5-858-121	Acquire Configuration Page	CTL*	[- / - / - / step]
5-858-122	Acquire Font Page	CTL*	[- / - / - / step]
5-858-123	Acquire Print Setting List	CTL*	[- / - / - / step]
5-858-124	Acquire Error Log	CTL*	[- / - / - / step]

Main SP Tables-5 (Controller)

5-858-131	Acquire Fax Info	CTL*	[- / - / - / step]
5-858-141	Acquire All Debug Logs	CTL*	[- / - / - / step]
5-858-142	Acquire Only Controller Debug Logs	CTL*	[- / - / - / step]
5-858-143	Acquire Only Engine Debug Logs	CTL*	[- / - / - / step]
5-858-144	Acquire Only Opepanel Debug Logs	CTL*	[- / - / - / step]
5-858-145	Acquire Only FCU Debug Logs	CTL*	[- / - / - / step]

<b>5860</b>	<b>[SMTP/POP3/IMAP4]</b>		
5-860-020	Partial Mail Receive Timeout	CTL*	[1 to 168 / <b>72</b> / 1 hour / step]
5-860-021	MDN Response RFC2298 Compliance	CTL*	[0 or 1 / <b>1</b> / 1 / step] 0: No, 1: Yes
5-860-022	SMTP Auth. From Field Replacement	CTL*	[0 or 1 / <b>0</b> / 1 / step]
5-860-025	SMTP Auth. Direct Setting	CTL*	[0 to 0xff / <b>0</b> / multipuls of 2 / step]
5-860-026	S/MIME: MIME Header Setting	CTL*	[0 to 2 / <b>0</b> / 1 / step] 0: Microsoft Outlook Express standard 1: Internet Draft standard 2: RFC standard
5-860-028	S/MIME: Authentication Check	CTL*	[0 or 1 / <b>0</b> / 1 / step] 0: Check 1: No check



<b>5866</b>	<b>[E-Mail Report]</b>		
5-866-001	Report Validity	CTL	[0 or 1 / <b>0</b> / 1 / step]
5-866-005	Add Date Field	CTL	[0 or 1 / <b>0</b> / 1 / step]

<b>5869</b>	<b>[RAM Disk Setting]</b>		
5-869-001	Mail Function	CTL	[0 or 1 / <b>0</b> / 1 / step] 0:OFF, 1:ON

<b>5870</b>	<b>[Common KeyInfo Writing]</b>		
5-870-001	Writing	CTL	[- / - / - / step]
5-870-003	Initialize	CTL	[- / - / - / step]
5-870-004	Writing: 2048bit	CTL	[- / - / - / step]

<b>5873</b>	<b>[SD Card Appli Move]</b>		
5-873-001	MoveExec	CTL	[- / - / - / step]
5-873-002	UndoExec	CTL	[- / - / - / step]

<b>5875</b>	<b>[SC Auto Reboot]</b>		
5-875-001	Reboot Setting	CTL*	[0 or 1 / <b>0</b> / 1 / step]
5-875-002	Reboot Type	CTL*	[0 or 1 / <b>1</b> / 1 / step] 0: Manual reboot, 1: Automatic reboot

<b>5878</b>	<b>[Option Setup]</b>		
5-878-001	Data Overwrite Security	CTL	[- / - / - / step]
5-878-002	HDD Encryption	CTL	[- / - / - / step]
5-878-004	OCR Dictionary	CTL	[- / - / - / step]

Main SP Tables-5 (Controller)

<b>5881</b>	<b>[Fixed Phrase Block Erasing]</b>		
5-881-001	-	CTL	[- / - / - / step]

<b>5885</b>	<b>[Set WIM Function]</b>		
5-885-020	DocSvr Acc Ctrl	CTL*	[8bit / <b>00000000</b> / bit switch / step] Bit Meaning 0: Forbid all document server access (1) 1: Forbid user mode access (1) 2: Forbid print function (1) 3: Forbid fax TX (1) 4: Forbid scan sending (1) 5: Forbid downloading (1) 6: Forbid delete (1) 7: Reserved
5-885-050	DocSvr Format	CTL*	[0 to 2 / <b>0</b> / 1 / step]
5-885-051	DocSvr Trans	CTL*	[5 to 20 / <b>10</b> / 1 / step]
5-885-100	Set Signature	CTL*	[0 to 2 / <b>0</b> / 1 / step]
5-885-101	Set Encryption	CTL*	[0 or 1 / <b>0</b> / 1 / step] 0: Not encrypted, 1:Encryption
5-885-200	Detect Mem Leak	CTL*	[8bit / <b>00000000</b> / bit switch / step]

<b>5886</b>	<b>[Farm Update Setting]</b>		
5-886-100	Skip Version Check	CTL*	[0 to 1 / <b>0</b> / 1 / step]
5-886-101	Skip LR Check	CTL*	[0 to 1 / <b>0</b> / 1 / step]
5-886-150	Cheetah Firm Exclusion	CTL*	[0 to 1 / <b>0</b> / 1 / step]

<b>5887</b>	<b>[SD Get Counter]</b>		
5-887-001	-	CTL	[- / - / - / step]

<b>5888</b>	<b>[Personal Information Protect]</b>		
5-888-001	-	CTL*	[0 or 1 / <b>0</b> / 1 / step]

<b>5893</b>	<b>[SDK Application Counter]</b>		
5-893-001	SDK-1	CTL	[- / - / - / step]
5-893-002	SDK-2	CTL	[- / - / - / step]
5-893-003	SDK-3	CTL	[- / - / - / step]
5-893-004	SDK-4	CTL	[- / - / - / step]
5-893-005	SDK-5	CTL	[- / - / - / step]
5-893-006	SDK-6	CTL	[- / - / - / step]
5-893-007	SDK-7	CTL	[- / - / - / step]
5-893-008	SDK-8	CTL	[- / - / - / step]
5-893-009	SDK-9	CTL	[- / - / - / step]
5-893-010	SDK-10	CTL	[- / - / - / step]
5-893-011	SDK-11	CTL	[- / - / - / step]
5-893-012	SDK-12	CTL	[- / - / - / step]

<b>5907</b>	<b>[Plug &amp; Play Maker/Model Name]</b>		
5-907-001	-	CTL*	[0 to 255 / <b>0</b> / 1 / step]

<b>5913</b>	<b>[Switchover Permission Time]</b>		
5-913-002	Print Application Timer	CTL*	[0 to 30 / <b>3</b> / 1 / step]

Main SP Tables-5 (Controller)

<b>5967</b>	<b>[Copy Server Set Function]</b>		
5-967-001	0: Enable, 1: Disable	CTL*	[0 or 1 / 0 / 1 / step] 0: Enable, 1: Disable

<b>5973</b>	<b>[User Stamp Registration]</b>		
5-973-101	Frame deletion setting	CTL*	[0 to 3 / 0 / 1 / step]

<b>5985</b>	<b>[Device Setting]</b>		
5-985-001	On Board NIC	CTL	[0 to 2 / 0 / 1 / step]
5-985-002	On Board USB	CTL	[0 or 1 / 0 / 1 / step]

<b>5990</b>	<b>[SP Print Mode]</b>		
5-990-001	All(Data List)	CTL	[- / - / - / step]
5-990-002	SP(Mode Data List)	CTL	[- / - / - / step]
5-990-003	User Program	CTL	[- / - / - / step]
5-990-004	Logging DataLogging Data	CTL	[- / - / - / step]
5-990-005	Diagnostic Report	CTL	[- / - / - / step]
5-990-006	Non-Default	CTL	[- / - / - / step]
5-990-007	NIB Summary	CTL	[- / - / - / step]
5-990-021	Copier User Program	CTL	[- / - / - / step]
5-990-022	Scanner SP	CTL	[- / - / - / step]
5-990-023	Scanner User Program	CTL	[- / - / - / step]
5-990-024	SDK/J Summary	CTL	[- / - / - / step]
5-990-025	SDK/J Application Info	CTL	[- / - / - / step]

5-990-026	Printer SP	CTL	[- / - / - / step]
-----------	------------	-----	--------------------

<b>5992</b>	<b>[SP Text Mode]</b>		
5-992-001	All(Data List)	CTL	[- / - / - / step]
5-992-002	SP(Mode Data List)	CTL	[- / - / - / step]
5-992-003	User Program	CTL	[- / - / - / step]
5-992-004	Logging Data	CTL	[- / - / - / step]
5-992-005	Diagnostic Report	CTL	[- / - / - / step]
5-992-006	Non-Default	CTL	[- / - / - / step]
5-992-007	NIB Summary	CTL	[- / - / - / step]
5-992-021	Copier User Program	CTL	[- / - / - / step]
5-992-022	Scanner SP	CTL	[- / - / - / step]
5-992-023	Scanner User Program	CTL	[- / - / - / step]
5-992-024	SDK/J Summary	CTL	[- / - / - / step]
5-992-025	SDK/J Application Info	CTL	[- / - / - / step]
5-992-026	Printer SP	CTL	[- / - / - / step]

## 3.8 MAIN SP TABLES-6

### 3.8.1 SP6-XXX (PERIPHERALS)

<b>6006</b>	<b>[ADF Adjustment]</b>		
6-006-001	Main Scan: Regist: Front Side	ENG*	[-3 to 3 / <b>0</b> / 0.1 mm / step]
6-006-002	Main Scan: Regist: Rear Side	ENG*	[-3 to 3 / <b>0</b> / 0.1 mm / step]
6-006-003	Sub Scan: Regist: Front Side	ENG*	[-5 to 5 / <b>0</b> / 0.1 mm / step]
6-006-004	Sub Scan: Regist: Rear Side	ENG*	[-5 to 5 / <b>0</b> / 0.1 mm / step]
6-006-007	Trailing Edge Erase Width	ENG*	[-5 to 5 / <b>-3</b> / 0.1 mm / step]

<b>6007</b>	<b>[ADF INPUT Check]</b>		
6-007-009	Original Detection Sensor	ENG	[0 or 1 / <b>0</b> / 1 / step]
6-007-013	Registration Sensor	ENG	[0 or 1 / <b>0</b> / 1 / step]
6-007-015	Feed Cover Sensor	ENG	[0 or 1 / <b>0</b> / 1 / step]
6-007-016	Lift-up Sensor	ENG	[0 or 1 / <b>0</b> / 1 / step]

<b>6008</b>	<b>[ADF OUTPUT Check]</b>		
6-008-003	Feed/Relay Motor FWD Rotation	ENG	[0 or 1 / <b>0</b> / 1 / step]
6-008-004	Feed/Relay Motor RVS Rotation	ENG	[0 or 1 / <b>0</b> / 1 / step]
6-008-009	Feed Clutch	ENG	[0 or 1 / <b>0</b> / 1 / step]

6-008-011	Reverse Solenoid	ENG	[0 or 1 / <b>0</b> / 1 / step]
-----------	------------------	-----	--------------------------------

<b>6011</b>	<b>[ADF INPUT Check]</b>		
6-011-004	DF_WSS_1	ENG	[0 or 1 / <b>0</b> / 1 / step]
6-011-005	DF_WSS_2	ENG	[0 or 1 / <b>0</b> / 1 / step]
6-011-006	DF_WSS_3	ENG	[0 or 1 / <b>0</b> / 1 / step]
6-011-007	DF_WSS_4	ENG	[0 or 1 / <b>0</b> / 1 / step]
6-011-008	DF_WSS_5	ENG	[0 or 1 / <b>0</b> / 1 / step]

<b>6016</b>	<b>[Original Size Detect Setting]</b>		
6-016-001	NA-1	ENG*	[0 to 2 / <b>0</b> / 1 / step] 0: DLT/LT(LEF)/11x15(SEF) 1: 10x14(SEF) 2 US EXE(LEF)
6-016-002	NA-2	ENG*	[0 or 1 / <b>0</b> / 1 / step] 0: LG/8.5x13/LT(SEF)/HLT(LEF) 1: 8x10(SEF)
6-016-003	EU-1	ENG*	[0 or 1 / <b>0</b> / 1 / step] 0: A3(SEF)/B4(SEF)/A4(LEF)/B5(LEF) 1: 8KAI(SEF)/16KAI(LEF)
6-016-004	EU-2	ENG*	[0 to 2 / <b>0</b> / 1 / step] 0: A4(SEF)/B5(SEF)/A5(LEF)/B6(LEF) 1: 8.5x13 2: 16KAI(SEF)

<b>6017</b>	<b>[ADF Adjustment: Sub Scan Mag]</b>		
6-017-001	-	ENG*	[-5 to 5 / <b>0</b> / 0.1% / step]

### 3.9 MAIN SP TABLES-7 (ENGINE)

#### 3.9.1 SP7-XXX (DATA LOG)

<b>7621</b>	<b>[PM Counter Display: Pages]</b>		
7-621-002	#PCDU	ENG*	[0 to 9999999 / <b>0</b> / 1 page / step]
7-621-115	120K part	ENG*	[0 to 9999999 / <b>0</b> / 1 page / step]

<b>7622</b>	<b>[PM Counter Reset]</b>		
7-622-002	#PCDU	ENG	[0 or 1 / <b>0</b> / 1 / step]
7-622-115	120K part	ENG	[0 or 1 / <b>0</b> / 1 / step]

<b>7625</b>	<b>[Previous Unit Counter: Pages]</b>		
7-625-002	#PCDU	ENG*	[0 to 9999999 / <b>0</b> / 1 page / step]
7-625-115	120K part	ENG*	[0 to 9999999 / <b>0</b> / 1 page / step]

<b>7801</b>	<b>[ROM Info.]</b>		
7-801-002	No.:Engine	ENG	[0 to 0 / <b>0</b> / 0 / step]
7-801-102	Version:Engine	ENG	[0 to 0 / <b>0</b> / 0 / step]

<b>7852</b>	<b>[DF Glass Dust Check]</b>		
7-852-001	Dust Detection: Counter	ENG*	[0 to 65535 / <b>0</b> / 1 / step]
7-852-002	Dust Detection: Clear Counter	ENG*	[0 to 65535 / <b>0</b> / 1 / step]

<b>7853</b>	<b>[Replacement Counter]</b>		
7-853-002	#PCDU	ENG*	[0 to 255 / <b>0</b> / 1 / step]



7-853-115	120K part	ENG*	[0 to 255 / 0 / 1 / step]
-----------	-----------	------	---------------------------

<b>7935</b>	<b>[Toner Bottle Log]</b>		
7-935-001	1: Bk Serial No.	ENG*	[0 to 255 / 0 / 1 / step]
7-935-002	1: Bk Attachment Date	ENG*	[0 to 255 / 0 / 1 / step]
7-935-005	2: Bk Serial No.	ENG*	[0 to 255 / 0 / 1 / step]
7-935-006	2: Bk Attachment Date	ENG*	[0 to 255 / 0 / 1 / step]
7-935-009	3: Bk Serial No.	ENG*	[0 to 255 / 0 / 1 / step]
7-935-010	3: Bk Attachment Date	ENG*	[0 to 255 / 0 / 1 / step]
7-935-013	4: Bk Serial No.	ENG*	[0 to 255 / 0 / 1 / step]
7-935-014	4: Bk Attachment Date	ENG*	[0 to 255 / 0 / 1 / step]
7-935-017	5: Bk Serial No.	ENG*	[0 to 255 / 0 / 1 / step]
7-935-018	5: Bk Attachment Date	ENG*	[0 to 255 / 0 / 1 / step]
7-935-021	6: Bk Serial No.	ENG*	[0 to 255 / 0 / 1 / step]
7-935-022	6: Bk Attachment Date	ENG*	[0 to 255 / 0 / 1 / step]
7-935-025	7: Bk Serial No.	ENG*	[0 to 255 / 0 / 1 / step]
7-935-026	7: Bk Attachment Date	ENG*	[0 to 255 / 0 / 1 / step]
7-935-029	8: Bk Serial No.	ENG*	[0 to 255 / 0 / 1 / step]
7-935-030	8: Bk Attachment Date	ENG*	[0 to 255 / 0 / 1 / step]
7-935-033	9: Bk Serial No.	ENG*	[0 to 255 / 0 / 1 / step]

Main SP Tables-7 (Engine)

7-935-034	9: Bk Attachment Date	ENG*	[0 to 255 / 0 / 1 / step]
7-935-037	10: Bk Serial No.	ENG*	[0 to 255 / 0 / 1 / step]
7-935-038	10: Bk Attachment Date	ENG*	[0 to 255 / 0 / 1 / step]

<b>7942</b>	<b>[PM Counter Display:Distance(%)]</b>		
7-942-002	#PCDU	ENG*	[0 to 255 / 0 / 1% / step]
7-942-115	120K part	ENG*	[0 to 255 / 0 / 1% / step]

<b>7944</b>	<b>[PM Counter Display: Distance]</b>		
7-944-002	#PCDU	ENG*	[0 to 999999999 / 0 / 1 mm / step]
7-944-115	120K part	ENG	[0 to 999999999 / 0 / 1 mm / step]

<b>7950</b>	<b>[Unit Replacement Date]</b>		
7-950-002	#PCDU	ENG*	[0 or 1 / 0 / 1 / step]
7-950-115	120K part	ENG*	[0 or 1 / 0 / 1 / step]

<b>7951</b>	<b>[Remaining Day Counter: Pages]</b>		
7-951-002	#PCDU	ENG*	[0 to 255 / 255 / 1 days / step]
7-951-115	120K part	ENG*	[0 to 255 / 255 / 1 days / step]

<b>7952</b>	<b>[Remaining Day Counter:Distance]</b>		
7-952-002	#PCDU	ENG*	[0 to 255 / 255 / 1 days / step]
7-952-115	120K part	ENG*	[0 to 255 / 255 / 1 days / step]

7953	[Operation Env. Log: PCU: K]		
7-953-001	T<0	ENG*	[0 to 999999999 / 0 / 1 mm / step]
7-953-002	0<=T<10:0<=H<15	ENG*	[0 to 999999999 / 0 / 1 mm / step]
7-953-003	0<=T<10:15<=H<30	ENG*	[0 to 999999999 / 0 / 1 mm / step]
7-953-004	0<=T<10:30<=H<55	ENG*	[0 to 999999999 / 0 / 1 mm / step]
7-953-005	0<=T<10:55<=H<80	ENG*	[0 to 999999999 / 0 / 1 mm / step]
7-953-006	0<=T<10:80<=H<=100	ENG*	[0 to 999999999 / 0 / 1 mm / step]
7-953-007	10<=T<15:0<=H<15	ENG*	[0 to 999999999 / 0 / 1 mm / step]
7-953-008	10<=T<15:15<=H<30	ENG*	[0 to 999999999 / 0 / 1 mm / step]
7-953-009	10<=T<15:30<=H<55	ENG*	[0 to 999999999 / 0 / 1 mm / step]
7-953-010	10<=T<15:55<=H<80	ENG*	[0 to 999999999 / 0 / 1 mm / step]
7-953-011	10<=T<15:80<=H<=100	ENG*	[0 to 999999999 / 0 / 1 mm / step]
7-953-012	15<=T<25:0<=H<15	ENG*	[0 to 999999999 / 0 / 1 mm / step]
7-953-013	15<=T<25:15<=H<30	ENG*	[0 to 999999999 / 0 / 1 mm / step]
7-953-014	15<=T<25:30<=H<55	ENG*	[0 to 999999999 / 0 / 1 mm / step]
7-953-015	15<=T<25:55<=H<80	ENG*	[0 to 999999999 / 0 / 1 mm / step]
7-953-016	15<=T<25:80<=H<=100	ENG*	[0 to 999999999 / 0 / 1 mm / step]
7-953-017	25<=T<27:0<=H<15	ENG*	[0 to 999999999 / 0 / 1 mm / step]
7-953-018	25<=T<27:15<=H<30	ENG*	[0 to 999999999 / 0 / 1 mm / step]
7-953-019	25<=T<27:30<=H<55	ENG*	[0 to 999999999 / 0 / 1 mm / step]
7-953-020	25<=T<27:55<=H<80	ENG*	[0 to 999999999 / 0 / 1 mm / step]
7-953-021	25<=T<27:80<=H<=100	ENG*	[0 to 999999999 / 0 / 1 mm / step]
7-953-022	27<=T<30:0<=H<15	ENG*	[0 to 999999999 / 0 / 1 mm / step]
7-953-023	27<=T<30:15<=H<30	ENG*	[0 to 999999999 / 0 / 1 mm / step]
7-953-024	27<=T<30:30<=H<55	ENG*	[0 to 999999999 / 0 / 1 mm / step]

Main SP Tables-7 (Engine)

7-953-025	27<=T<30:55<=H<80	ENG*	[0 to 999999999 / 0 / 1 mm / step]
7-953-026	27<=T<30:80<=H<=100	ENG*	[0 to 999999999 / 0 / 1 mm / step]
7-953-027	30<=T<=32:0<=H<15	ENG*	[0 to 999999999 / 0 / 1 mm / step]
7-953-028	30<=T<=32:15<=H<30	ENG*	[0 to 999999999 / 0 / 1 mm / step]
7-953-029	30<=T<=32:30<=H<55	ENG*	[0 to 999999999 / 0 / 1 mm / step]
7-953-030	30<=T<=32:55<=H<80	ENG*	[0 to 999999999 / 0 / 1 mm / step]
7-953-031	30<=T<=32:80<=H<=100	ENG*	[0 to 999999999 / 0 / 1 mm / step]
7-953-032	32<T<35:0<=H<15	ENG*	[0 to 999999999 / 0 / 1 mm / step]
7-953-033	32<T<35:15<=H<30	ENG*	[0 to 999999999 / 0 / 1 mm / step]
7-953-034	32<T<35:30<=H<55	ENG*	[0 to 999999999 / 0 / 1 mm / step]
7-953-035	32<T<35:55<=H<80	ENG*	[0 to 999999999 / 0 / 1 mm / step]
7-953-036	32<T<35:80<=H<=100	ENG*	[0 to 999999999 / 0 / 1 mm / step]
7-953-037	35<=T:0<=H<=100	ENG*	[0 to 999999999 / 0 / 1 mm / step]
7-953-100	Log Clear	ENG	[0 or 1 / 0 / 1 1 / step]

<b>7954</b>	<b>[PM Counter Display: Pages(%)]</b>		
7-954-002	#PCDU	ENG*	[0 to 255 / 0 / 1% / step]
7-954-115	120K part	ENG*	[0 to 255 / 0 / 1% / step]

<b>7955</b>	<b>[Estimated Remaining Pages]</b>		
7-955-002	#PCDU	ENG*	[0 to 9999999 / 0 / 1 page / step]
7-955-115	120K part	ENG*	[0 to 9999999 / 0 / 1 page / step]

<b>7956</b>	<b>[Estimated Remaining Days]</b>		
7-956-002	#PCDU	ENG*	[0 to 255 / 255 / 1 days / step]
7-956-115	120K part	ENG*	[0 to 255 / 255 / 1 days / step]

7960	[Estimated Usage Rate]		
7-960-002	#PCDU	ENG*	[0 to 255 / 0 / 1% / step]
7-960-115	120K part	ENG*	[0 to 255 / 0 / 1% / step]

## 3.10 MAIN SP TABLES-7 (CONTROLLER)

### 3.10.1 SP7-XXX (DATA LOG)

<b>7401</b>	<b>[Total SC]</b>		
7-401-001	SC Counter	CTL*	[00000 to 65535 / 0 / 0 / step]
7-401-002	Total SC Counter	CTL*	[00000 to 65535 / 0 / 0 / step]

<b>7403</b>	<b>[SC History]</b>		
7-403-001	Latest	CTL*	[- / - / - / step]
7-403-002	Latest 1	CTL*	[- / - / - / step]
7-403-003	Latest 2	CTL*	[- / - / - / step]
7-403-004	Latest 3	CTL*	[- / - / - / step]
7-403-005	Latest 4	CTL*	[- / - / - / step]
7-403-006	Latest 5	CTL*	[- / - / - / step]
7-403-007	Latest 6	CTL*	[- / - / - / step]
7-403-008	Latest 7	CTL*	[- / - / - / step]
7-403-009	Latest 8	CTL*	[- / - / - / step]
7-403-010	Latest 9	CTL*	[- / - / - / step]

<b>7404</b>	<b>[Software Error History]</b>		
7-404-001	Latest	CTL*	[- / - / - / step]
7-404-002	Latest 1	CTL*	[- / - / - / step]
7-404-003	Latest 2	CTL*	[- / - / - / step]
7-404-004	Latest 3	CTL*	[- / - / - / step]
7-404-005	Latest 4	CTL*	[- / - / - / step]
7-404-006	Latest 5	CTL*	[- / - / - / step]

7-404-007	Latest 6	CTL*	[- / - / - / step]
7-404-008	Latest 7	CTL*	[- / - / - / step]
7-404-009	Latest 8	CTL*	[- / - / - / step]
7-404-010	Latest 9	CTL*	[- / - / - / step]

<b>7502</b>	<b>[Total Paper Jam]</b>		
7-502-001	Jam Counter	CTL*	[00000 to 65535 / 0 / 0 / step]
7-502-002	Total Jam Counter	CTL*	[00000 to 65535 / 0 / 0 / step]

<b>7503</b>	<b>[Total Original Jam Counter]</b>		
7-503-001		CTL*	[00000 to 65535 / 0 / 0 / step]
<b>7503</b>	<b>[Total Original Jam]</b>		
7-503-002	Total Original Counter	CTL*	[00000 to 65535 / 0 / 0 / step]

<b>7504</b>	<b>[Paper Jam Location]</b>		
7-504-001	At Power On	CTL*	[00000 to 65535 / 0 / 0 / step]
7-504-003	Tray 1: On	CTL*	[00000 to 65535 / 0 / 0 / step]
7-504-005	Tray 2: On	CTL*	[00000 to 65535 / 0 / 0 / step]
7-504-008	Registration Sn: On (Bypass)	CTL*	[00000 to 65535 / 0 / 0 / step]
7-504-009	Registration Sn: On (Duplex)	CTL*	[00000 to 65535 / 0 / 0 / step]
7-504-017	Registration Sn: On (Bank)	CTL*	[00000 to 65535 / 0 / 0 / step]
7-504-020	Paper Exit: On	CTL*	[00000 to 65535 / 0 / 0 / step]
7-504-025	Duplex Exit: On	CTL*	[00000 to 65535 / 0 / 0 / step]

Main SP Tables-7 (Controller)

7-504-027	Duplex Entrance: On	CTL*	[00000 to 65535 / 0 / 0 / step]
7-504-053	Bank: Transport 1: Off	CTL*	[00000 to 65535 / 0 / 0 / step]
7-504-057	Registration Sensor: Off	CTL*	[00000 to 65535 / 0 / 0 / step]
7-504-060	Paper Exit: Off	CTL*	[00000 to 65535 / 0 / 0 / step]
7-504-065	Duplex Exit: Off	CTL*	[00000 to 65535 / 0 / 0 / step]
7-504-067	Duplex Entrance: Off	CTL*	[00000 to 65535 / 0 / 0 / step]

<b>7505</b>	<b>[Original Jam Detection]</b>		
7-505-001	At Power On	CTL*	[00000 to 65535 / 0 / 0 / step]
7-505-004	Registration Sensor: On	CTL*	[00000 to 65535 / 0 / 0 / step]
7-505-054	Registration Sensor: Off	CTL*	[00000 to 65535 / 0 / 0 / step]
7-505-100	Motor Error	CTL*	[00000 to 65535 / 0 / 0 / step]

<b>7506</b>	<b>[Jam Count by Paper Size]</b>		
7-506-005	A4 LEF	CTL*	[00000 to 65535 / 0 / 0 / step]
7-506-006	A5 LEF	CTL*	[00000 to 65535 / 0 / 0 / step]
7-506-014	B5 LEF	CTL*	[00000 to 65535 / 0 / 0 / step]
7-506-038	LT LEF	CTL*	[00000 to 65535 / 0 / 0 / step]
7-506-044	HLT LEF	CTL*	[00000 to 65535 / 0 / 0 / step]
7-506-132	A3 SEF	CTL*	[00000 to 65535 / 0 / 0 / step]
7-506-133	A4 SEF	CTL*	[00000 to 65535 / 0 / 0 / step]
7-506-134	A5 SEF	CTL*	[00000 to 65535 / 0 / 0 / step]



7-506-141	B4 SEF	CTL*	[00000 to 65535 / 0 / 0 / step]
7-506-142	B5 SEF	CTL*	[00000 to 65535 / 0 / 0 / step]
7-506-160	DLT SEF	CTL*	[00000 to 65535 / 0 / 0 / step]
7-506-164	LG SEF	CTL*	[00000 to 65535 / 0 / 0 / step]
7-506-166	LT SEF	CTL*	[00000 to 65535 / 0 / 0 / step]
7-506-172	HLT SEF	CTL*	[00000 to 65535 / 0 / 0 / step]
7-506-255	Others	CTL*	[00000 to 65535 / 0 / 0 / step]

<b>7507</b>	<b>[Plotter Jam History]</b>		
7-507-001	Latest	CTL*	[- / - / - / step]
7-507-002	Latest 1	CTL*	[- / - / - / step]
7-507-003	Latest 2	CTL*	[- / - / - / step]
7-507-004	Latest 3	CTL*	[- / - / - / step]
7-507-005	Latest 4	CTL*	[- / - / - / step]
7-507-006	Latest 5	CTL*	[- / - / - / step]
7-507-007	Latest 6	CTL*	[- / - / - / step]
7-507-008	Latest 7	CTL*	[- / - / - / step]
7-507-009	Latest 8	CTL*	[- / - / - / step]
7-507-010	Latest 9	CTL*	[- / - / - / step]

<b>7508</b>	<b>[Original Jam History]</b>		
7-508-001	Latest	CTL*	[- / - / - / step]
7-508-002	Latest 1	CTL*	[- / - / - / step]
7-508-003	Latest 2	CTL*	[- / - / - / step]
7-508-004	Latest 3	CTL*	[- / - / - / step]
7-508-005	Latest 4	CTL*	[- / - / - / step]

Main SP Tables-7 (Controller)

7-508-006	Latest 5	CTL*	[- / - / - / step]
7-508-007	Latest 6	CTL*	[- / - / - / step]
7-508-008	Latest 7	CTL*	[- / - / - / step]
7-508-009	Latest 8	CTL*	[- / - / - / step]
7-508-010	Latest 9	CTL*	[- / - / - / step]

<b>7514</b>	<b>[Paper Jam Count by Location]</b>		
7-514-001	At Power On	CTL*	[00000 to 65535 / 0 / 0 / step]
7-514-003	Tray 1: On	CTL*	[00000 to 65535 / 0 / 0 / step]
7-514-005	Tray 2: On	CTL*	[00000 to 65535 / 0 / 0 / step]
7-514-008	Registration Sn: On (Bypass)	CTL*	[00000 to 65535 / 0 / 0 / step]
7-514-009	Registration Sn: On (Duplex)	CTL*	[00000 to 65535 / 0 / 0 / step]
7-514-017	Registration Sn: On (Bank)	CTL*	[00000 to 65535 / 0 / 0 / step]
7-514-020	Paper Exit: On	CTL*	[00000 to 65535 / 0 / 0 / step]
7-514-025	Duplex Exit: On	CTL*	[00000 to 65535 / 0 / 0 / step]
7-514-027	Duplex Entrance: On	CTL*	[00000 to 65535 / 0 / 0 / step]
7-514-053	Bank: Transport 1: Off	CTL*	[00000 to 65535 / 0 / 0 / step]
7-514-057	Registration Sensor: Off	CTL*	[00000 to 65535 / 0 / 0 / step]
7-514-060	Paper Exit: Off	CTL*	[00000 to 65535 / 0 / 0 / step]
7-514-065	Duplex Exit: Off	CTL*	[00000 to 65535 / 0 / 0 / step]
7-514-067	Duplex Entrance: Off	CTL*	[00000 to 65535 / 0 / 0 / step]

<b>7515</b>	<b>[Original Jam Count by Detection]</b>		
7-515-001	At Power On	CTL*	[00000 to 65535 / 0 / 0 / step]
7-515-004	Registration Sensor: On	CTL*	[00000 to 65535 / 0 / 0 / step]
7-515-054	Registration Sensor: Off	CTL*	[00000 to 65535 / 0 / 0 / step]
7-515-100	Motor Error	CTL*	[00000 to 65535 / 0 / 0 / step]

<b>7516</b>	<b>[Paper Size Jam Count]</b>		
7-516-005	A4 LEF	CTL*	[00000 to 65535 / 0 / 0 / step]
7-516-006	A5 LEF	CTL*	[00000 to 65535 / 0 / 0 / step]
7-516-014	B5 LEF	CTL*	[00000 to 65535 / 0 / 0 / step]
7-516-038	LT LEF	CTL*	[00000 to 65535 / 0 / 0 / step]
7-516-044	HLT LEF	CTL*	[00000 to 65535 / 0 / 0 / step]
7-516-132	A3 SEF	CTL*	[00000 to 65535 / 0 / 0 / step]
7-516-133	A4 SEF	CTL*	[00000 to 65535 / 0 / 0 / step]
7-516-134	A5 SEF	CTL*	[00000 to 65535 / 0 / 0 / step]
7-516-141	B4 SEF	CTL*	[00000 to 65535 / 0 / 0 / step]
7-516-142	B5 SEF	CTL*	[00000 to 65535 / 0 / 0 / step]
7-516-160	DLT SEF	CTL*	[00000 to 65535 / 0 / 0 / step]
7-516-164	LG SEF	CTL*	[00000 to 65535 / 0 / 0 / step]
7-516-166	LT SEF	CTL*	[00000 to 65535 / 0 / 0 / step]
7-516-172	HLT SEF	CTL*	[00000 to 65535 / 0 / 0 / step]
7-516-255	Others	CTL*	[00000 to 65535 / 0 / 0 / step]

## Main SP Tables-7 (Controller)

<b>7520</b>	<b>[Update Log]</b>		
7-520-001	Error Record 1	CTL*	[0 to 255 / 0 / 1 / step]
7-520-002	Error Record 2	CTL*	[0 to 255 / 0 / 1 / step]
7-520-003	Error Record 3	CTL*	[0 to 255 / 0 / 1 / step]
7-520-004	Error Record 4	CTL*	[0 to 255 / 0 / 1 / step]
7-520-005	Error Record 5	CTL*	[0 to 255 / 0 / 1 / step]
7-520-006	Error Record 6	CTL*	[0 to 255 / 0 / 1 / step]
7-520-007	Error Record 7	CTL*	[0 to 255 / 0 / 1 / step]
7-520-008	Error Record 8	CTL*	[0 to 255 / 0 / 1 / step]
7-520-009	Error Record 9	CTL*	[0 to 255 / 0 / 1 / step]
7-520-010	Error Record 10	CTL*	[0 to 255 / 0 / 1 / step]

<b>7624</b>	<b>[Part Replacement Operation ON/OFF]</b>		
7-624-001	PCU	CTL*	[0 or 1 / 1 / 1 / step]
7-624-002	Maintenance Parts	CTL*	[0 or 1 / 1 / 1 / step]

<b>7801</b>	<b>[ROM No/ Firmware Version]</b>		
7-801-255	-	CTL	[- / - / - / step]

<b>7803</b>	<b>[PM Counter Display]</b>		
7-803-001	Paper	CTL*	[0 to 9999999 / - / - / step]

<b>7804</b>	<b>[PM Counter Reset]</b>		
7-804-001	PM Counter Reset	CTL	[- / - / - / step]

<b>7807</b>	<b>[SC/Jam Counter Reset]</b>		
7-807-001	-	CTL	[- / - / - / step]

<b>7826</b>	<b>[MF Error Counter]</b>		
7-826-001	Error Total	CTL*	[0 to 99999999 / - / - / step]
7-826-002	Error Staple	CTL*	[0 to 99999999 / - / - / step]

<b>7827</b>	<b>[MF Error Couter Clear]</b>		
7-827-001	-	CTL	[- / - / - / step]

<b>7832</b>	<b>[Self-Diagnose Result Display]</b>		
7-832-001	-	CTL	[- / - / - / step]

<b>7836</b>	<b>[Total Memory Size]</b>		
7-836-001	-	CTL	[0 to 0xffffffff / - / - MB / step]

<b>7840</b>	<b>[Service SP Entry Code Chg Hist]</b>		
7-840-001	Change Time :Latest	CTL*	[- / - / - / step]
7-840-002	Change Time :Last1	CTL*	[- / - / - / step]
7-840-101	Initialize Time :Latest	CTL*	[- / - / - / step]
7-840-102	Initialize Time :Last1	CTL*	[- / - / - / step]

Main SP Tables-7 (Controller)

<b>7901</b>	<b>[Assert Info.]</b>		
7-901-001	File Name	CTL*	[- / - / - / step]
7-901-002	Number of Lines	CTL*	[- / - / - / step]
7-901-003	Location	CTL*	[- / - / - / step]

<b>7910</b>	<b>[ROM No]</b>		
7-910-001	System/Copy	CTL*	[- / - / - / step]
7-910-002	Engine	CTL*	[- / - / - / step]
7-910-003	Lcdc	CTL*	[- / - / - / step]
7-910-012	FCU	CTL*	[- / - / - / step]
7-910-018	NetworkSupport	CTL*	[- / - / - / step]
7-910-023	HDD Format Option	CTL*	[- / - / - / step]
7-910-132	NetWare	CTL*	[- / - / - / step]
7-910-150	RPCS	CTL*	[- / - / - / step]
7-910-151	PS	CTL*	[- / - / - / step]
7-910-152	RPDL	CTL*	[- / - / - / step]
7-910-158	PCL	CTL*	[- / - / - / step]
7-910-159	PCLXL	CTL*	[- / - / - / step]
7-910-162	PDF	CTL*	[- / - / - / step]
7-910-165	PJL	CTL*	[- / - / - / step]
7-910-167	MediaPrint:JPEG	CTL*	[- / - / - / step]
7-910-168	MediaPrint:TIFF	CTL*	[- / - / - / step]
7-910-169	XPS	CTL*	[- / - / - / step]
7-910-180	FONT	CTL*	[- / - / - / step]
7-910-181	FONT1	CTL*	[- / - / - / step]

7-910-182	FONT2	CTL*	[- / - / - / step]
7-910-183	FONT3	CTL*	[- / - / - / step]
7-910-184	FONT4	CTL*	[- / - / - / step]
7-910-185	FONT5	CTL*	[- / - / - / step]
7-910-200	Factory	CTL*	[- / - / - / step]
7-910-201	Copy	CTL*	[- / - / - / step]
7-910-202	NetworkDocBox	CTL*	[- / - / - / step]
7-910-203	FAX	CTL*	[- / - / - / step]
7-910-204	Printer	CTL*	[- / - / - / step]
7-910-205	Scanner	CTL*	[- / - / - / step]
7-910-206	RFax	CTL*	[- / - / - / step]
7-910-210	MIB	CTL*	[- / - / - / step]
7-910-211	Websupport	CTL*	[- / - / - / step]
7-910-212	WebUapl	CTL*	[- / - / - / step]
7-910-213	SDK1	CTL*	[- / - / - / step]
7-910-214	SDK2	CTL*	[- / - / - / step]
7-910-215	SDK3	CTL*	[- / - / - / step]
7-910-250	Package	CTL*	[- / - / - / step]

## Main SP Tables-7 (Controller)

7911	[Firmware Version]		
7-911-001	System/Copy	CTL*	[- / - / - / step]
7-911-002	Engine	CTL*	[- / - / - / step]
7-911-003	Lcdc	CTL*	[- / - / - / step]
7-911-012	FCU	CTL*	[- / - / - / step]
7-911-018	NetworkSupport	CTL*	[- / - / - / step]
7-911-023	HDD Format Option	CTL*	[- / - / - / step]
7-911-132	NetWare	CTL*	[- / - / - / step]
7-911-150	RPCS	CTL*	[- / - / - / step]
7-911-151	PS	CTL*	[- / - / - / step]
7-911-158	PCL	CTL*	[- / - / - / step]
7-911-159	PCLXL	CTL*	[- / - / - / step]
7-911-162	PDF	CTL*	[- / - / - / step]
7-911-165	PJL	CTL*	[- / - / - / step]
7-911-167	MediaPrint:JPEG	CTL*	[- / - / - / step]
7-911-168	MediaPrint:TIFF	CTL*	[- / - / - / step]
7-911-169	XPS	CTL*	[- / - / - / step]
7-911-180	FONT	CTL*	[- / - / - / step]
7-911-181	FONT1	CTL*	[- / - / - / step]
7-911-182	FONT2	CTL*	[- / - / - / step]
7-911-183	FONT3	CTL*	[- / - / - / step]
7-911-184	FONT4	CTL*	[- / - / - / step]
7-911-185	FONT5	CTL*	[- / - / - / step]
7-911-200	Factory	CTL*	[- / - / - / step]
7-911-201	Copy	CTL*	[- / - / - / step]



7-911-202	NetworkDocBox	CTL*	[- / - / - / step]
7-911-203	FAX	CTL*	[- / - / - / step]
7-911-204	Printer	CTL*	[- / - / - / step]
7-911-205	Scanner	CTL*	[- / - / - / step]
7-911-206	RFax	CTL*	[- / - / - / step]
7-911-210	MIB	CTL*	[- / - / - / step]
7-911-211	Websupport	CTL*	[- / - / - / step]
7-911-212	WebUapl	CTL*	[- / - / - / step]
7-911-213	SDK1	CTL*	[- / - / - / step]
7-911-214	SDK2	CTL*	[- / - / - / step]
7-911-215	SDK3	CTL*	[- / - / - / step]
7-911-250	Package	CTL*	[- / - / - / step]

## 3.11 MAIN SP TABLES-8

### 3.11.1 SP8-XXX (DATA LOG2)

Many of these counters are provided for features that are currently not available, such as sending color faxes, and so on. However, here are some Group 8 codes that when used in combination with others, can provide useful information.

SP Numbers	What They Do
SP8211 to SP8216	The number of pages scanned to the document server.
SP8401 to SP8406	The number of pages printed from the document server.
SP8691 to SP8696	The number of pages sent from the document server.

Specifically, the following questions can be answered:

- How is the document server actually being used?
- What application is using the document server most frequently?
- What data in the document server is being reused?

Most of the SPs in this group are prefixed with a letter that indicates the mode of operation (the mode of operation is referred to as an "application"). Before reading the Group 8 Service Table, make sure that you understand what these prefixes mean.

Prefixes	What it means	
T:	Total: (Grand Total).	Grand total of the items counted for all applications (C, F, P, etc.).
C:	Copy application.	Totals (pages, jobs, etc.) executed for each application when the job was not stored on the document server.
F:	Fax application.	
P:	Print application.	
S:	Scan application.	

Prefixes	What it means	
L:	Local storage (document server)	Totals (jobs, pages, etc.) for the document server. The L: counters work differently case by case. Sometimes, they count jobs/pages stored on the document server; this can be in document server mode (from the document server window), or from another mode, such as from a printer driver or by pressing the Store File button in the Copy mode window. Sometimes, they include occasions when the user uses a file that is already on the document server. Each counter will be discussed case by case.
O:	Other applications (external network applications, for example)	Refers to network applications such as Web Image Monitor. Utilities developed with the SDK (Software Development Kit) will also be counted with this group in the future.

The Group 8 SP codes are limited to 17 characters, forced by the necessity of displaying them on the small LCDs of printers and faxes that also use these SPs. Read over the list of abbreviations below and refer to it again if you see the name of an SP that you do not understand.

#### Key for Abbreviations

Abbreviation	What it means
/	"By", e.g. "T:Jobs/Apl" = Total Jobs "by" Application
>	More (2> "2 or more", 4> "4 or more")
AddBook	Address Book
Apl	Application
B/W	Black & White
Bk	Black
C	Cyan
ColCr	Color Create
ColMode	Color Mode

Abbreviation	What it means
Comb	Combine
Comp	Compression
Deliv	Delivery
DesApl	Designated Application. The application (Copy, Fax, Scan, Print) used to store the job on the document server, for example.
Dev Counter	Development Count, no. of pages developed.
Dup, Duplex	Duplex, printing on both sides
Emul	Emulation
FC	Full Color
FIN	Post-print processing, i.e. finishing (punching, stapling, etc.)
Full Bleed	No Margins
GenCopy	Generation Copy Mode
GPC	Get Print Counter. For jobs 10 pages or less, this counter does not count up. For jobs larger than 10 pages, this counter counts up by the number that is in excess of 10 (e.g., for an 11-page job, the counter counts up 11-10 =1)
IFax	Internet Fax
ImgEdt	Image Edit performed on the original with the copier GUI, e.g. border removal, adding stamps, page numbers, etc.
K	Black (YMCK)
LS	Local Storage. Refers to the document server.
LSize	Large (paper) Size
Mag	Magnification
MC	One color (monochrome)

Abbreviation	What it means
NRS	New Remote Service, which allows a service center to monitor machines remotely. "NRS" is used overseas, "CSS" is used in Japan.
Org	Original for scanning
OrgJam	Original Jam
Palm 2	Print Job Manager/Desk Top Editor: A pair of utilities that allows print jobs to be distributed evenly among the printers on the network, and allows files to moved around, combined, and converted to different formats.
PC	Personal Computer
PGS	Pages. A page is the total scanned surface of the original. Duplex pages count as two pages, and A3 simplex count as two pages if the A3/DLT counter SP is switched ON.
PJob	Print Jobs
Ppr	Paper
PrtJam	Printer (plotter) Jam
PrtPGS	Print Pages
R	Red (Toner Remaining). Applies to the wide format model A2 only. This machine is under development and currently not available.
Rez	Resolution
SC	Service Code (Error SC code displayed)
Scn	Scan
Sim, Simplex	Simplex, printing on 1 side.
S-to-Email	Scan-to-E-mail
SMC	SMC report printed with SP5990. All of the Group 8 counters are recorded in the SMC report.
Svr	Server

Abbreviation	What it means
TonEnd	Toner End
TonSave	Toner Save
TXJob	Send, Transmission
YMC	Yellow, Magenta, Cyan
YMCK	Yellow, Magenta, Cyan, Black

**Note**

- All of the Group 8 SPs are reset with SP5 801 1 Memory All Clear.

<b>8001</b>	T:Total Jobs	*CTL	These SPs count the number of times each application is used to do a job. [0 to 9999999/ - / 1] <b>Note:</b> The L: counter is the total number of times the other applications are used to send a job to the document server, plus the number of times a file already on the document server is used.
<b>8002</b>	C:Total Jobs	*CTL	
<b>8003</b>	F:Total Jobs	*CTL	
<b>8004</b>	P:Total Jobs	*CTL	
<b>8005</b>	S:Total Jobs	*CTL	
<b>8006</b>	L:Total Jobs	*CTL	

- These SPs reveal the number of times an application is used, not the number of pages processed.
- When an application is opened for image input or output, this counts as one job.
- Interrupted jobs (paper jams, etc.) are counted, even though they do not finish.
- Only jobs executed by the customer are counted. Jobs executed by the customer engineer using the SP modes are not counted.
- When using secure printing (when a password is required to start the print job), the job is counted at the time when either "Delete Data" or "Specify Output" is specified.
- A job is counted as a fax job when the job is stored for sending.
- When a fax is received to fax memory, the F: counter increments but the L: counter does not (the document server is not used).
- A fax broadcast counts as one job for the F: counter (the fax destinations in the broadcast are not counted separately).
- A fax broadcast is counted only after all the faxes have been sent to their destinations. If one transmission generates an error, then the broadcast will not be counted until the transmission

has been completed.

- A printed fax report counts as one job for the F: counter.
- The F: counter does not distinguish between fax sending or receiving.
- When a copy job on the document server is printed, SP8022 also increments, and when a print job stored on the document server is printed, SP8024 also increments.
- When an original is both copied and stored on the document server, the C: and L: counters both increment.
- When a print job is stored on the document server, only the L: counter increments.
- When the user presses the Document Server button to store the job on the document server, only the L: counter increments.
- When the user enters document server mode and prints data stored on the document server, only the L: counter increments.
- When an image received from Palm 2 is received and stored, the L: counter increments.
- When the customer prints a report (user code list, for example), the O: counter increments. However, for fax reports and reports executed from the fax application, the F: counter increments.

<b>8011</b>	T:Jobs/LS	*CTL	These SPs count the number of jobs stored to the document server by each application, to reveal how local storage is being used for input. [0 to 99999999/ - / 1] The L: counter counts the number of jobs stored from within the document server mode screen at the operation panel.
<b>8012</b>	C:Jobs/LS	*CTL	
<b>8013</b>	F:Jobs/LS	*CTL	
<b>8014</b>	P:Jobs/LS	*CTL	
<b>8015</b>	S:Jobs/LS	*CTL	
<b>8016</b>	L:Jobs/LS	*CTL	
<b>8017</b>	O:Jobs/LS	*CTL	

- When a scan job is sent to the document server, the S: counter increments. When you enter document server mode and then scan an original, the L: counter increments.
- When a print job is sent to the document server, the P: counter increments.
- When a network application sends data to the document server, the O: counter increments.
- When an image from Palm 2 is stored on the document server, the O: counter increments.
- When a fax is sent to the document server, the F: counter increments.

<b>8021</b>	T:Pjob/LS	*CTL	These SPs reveal how files printed from the document server were stored on the document server originally. [0 to 99999999 / - / 1] The L: counter counts the number of jobs stored from within the document server mode screen at the operation panel.
<b>8022</b>	C:Pjob/LS	*CTL	
<b>8023</b>	F:Pjob/LS	*CTL	
<b>8024</b>	P:Pjob/LS	*CTL	
<b>8025</b>	S:Pjob/LS	*CTL	
<b>8026</b>	L:Pjob/LS	*CTL	
<b>8027</b>	O:Pjob/LS	*CTL	

- When a copy job stored on the document server is printed with another application, the C: counter increments.
- When an application like DeskTopBinder merges a copy job that was stored on the document server with a print job that was stored on the document server, the C: and P: counters both increment.
- When a job already on the document server is printed with another application, the L: counter increments.
- When a scanner job stored on the document server is printed with another application, the S: counter increments. If the original was scanned from within document server mode, then the L: counter increments.
- When images stored on the document server by a network application (including Palm 2), are printed with another application, the O: counter increments.
- When a copy job stored on the document server is printed with a network application (Web Image Monitor, for example), the C: counter increments.
- When a fax on the document server is printed, the F: counter increments.



<b>8031</b>	T:Pjob/DesApl	*CTL	These SPs reveal what applications were used to output documents from the document server. [0 to 9999999/ - / 1] The L: counter counts the number of jobs printed from within the document server mode screen at the operation panel.
<b>8032</b>	C:Pjob/DesApl	*CTL	
<b>8033</b>	F:Pjob/DesApl	*CTL	
<b>8034</b>	P:Pjob/DesApl	*CTL	
<b>8035</b>	S:Pjob/DesApl	*CTL	
<b>8036</b>	L:Pjob/DesApl	*CTL	
<b>8037</b>	O:Pjob/DesApl	*CTL	

- When documents already stored on the document server are printed, the count for the application that started the print job is incremented.
- When the print job is started from a network application (Desk Top Binder, Web Image Monitor, etc.) the L: counter increments.

<b>8041</b>	T:TX Jobs/LS	*CTL	These SPs count the applications that stored files on the document server that were later accessed for transmission over the telephone line or over a network (attached to an e-mail, or as a fax image by I-Fax). [0 to 9999999/ - / 1] <b>Note:</b> Jobs merged for sending are counted separately. The L: counter counts the number of jobs scanned from within the document server mode screen at the operation panel.
<b>8042</b>	C:TX Jobs/LS	*CTL	
<b>8043</b>	F:TX Jobs/LS	*CTL	
<b>8044</b>	P:TX Jobs/LS	*CTL	
<b>8045</b>	S:TX Jobs/LS	*CTL	
<b>8046</b>	L:TX Jobs/LS	*CTL	
<b>8047</b>	O:TX Jobs/LS	*CTL	

- When a stored copy job is sent from the document server, the C: counter increments.
- When images stored on the document server by a network application or Palm2 are sent as an e-mail, the O: counter increments.

<b>8051</b>	T:TX Jobs/DesApl	*CTL	These SPs count the applications used to send files from the document server over the telephone line or over a network (attached to an e-mail, or as a fax image by I-Fax). Jobs merged for sending are counted separately. [0 to 9999999/ - / 1]  The L: counter counts the number of jobs sent from within the document server mode screen at the operation panel.
<b>8052</b>	C:TX Jobs/DesApl	*CTL	
<b>8053</b>	F:TX Jobs/DesApl	*CTL	
<b>8054</b>	P:TX Jobs/DesApl	*CTL	
<b>8055</b>	S:TX Jobs/DesApl	*CTL	
<b>8056</b>	L:TX Jobs/DesApl	*CTL	
<b>8057</b>	O:TX Jobs/DesApl	*CTL	

- If the send is started from Desk Top Binder or Web Image Monitor, for example, then the O: counter increments.

<b>8061</b>	T:FIN Jobs	*CTL	[0 to 9999999/ 0 / 1/step]
	These SPs total the finishing methods. The finishing method is specified by the application.		
<b>8062</b>	C:FIN Jobs	*CTL	[0 to 9999999/ 0 / 1/step]
	These SPs total finishing methods for copy jobs only. The finishing method is specified by the application.		
<b>8063</b>	F:FIN Jobs	*CTL	[0 to 9999999/ 0 / 1/step]
	These SPs total finishing methods for fax jobs only. The finishing method is specified by the application. <b>Note:</b> Finishing features for fax jobs are not available at this time.		
<b>8064</b>	P:FIN Jobs	*CTL	[0 to 9999999/ 0 / 1/step]
	These SPs total finishing methods for print jobs only. The finishing method is specified by the application.		
<b>8065</b>	S:FIN Jobs	*CTL	[0 to 9999999/ 0 / 1/step]
	These SPs total finishing methods for scan jobs only. The finishing method is specified by the application. <b>Note:</b> Finishing features for scan jobs are not available at this time.		

<b>8066</b>	L:FIN Jobs	*CTL	[0 to 9999999/ 0 / 1/step]
	These SPs total finishing methods for jobs output from within the document server mode screen at the operation panel. The finishing method is specified from the print window within document server mode.		
<b>8067</b>	O:FIN Jobs	*CTL	[0 to 9999999/ 0 / 1/step]
	These SPs total finishing methods for jobs executed by an external application, over the network. The finishing method is specified by the application.		

**Last three digits for SP8 061 to 067**

806x-001	Sort	Number of jobs started in Sort mode. When a stored copy job is set for Sort and then stored on the document server, the L: counter increments. (See SP8 066 1)
806x-002	Stack	Number of jobs started out of Sort mode.
806x-003	Staple	Number of jobs started in Staple mode.
806x-004	Booklet	Number of jobs started in Booklet mode. If the machine is in staple mode, the Staple counter also increments.
806x-005	Z-Fold	Number of jobs started In any mode other than the Booklet mode and set for folding (Z-fold).
806x-006	Punch	Number of jobs started in Punch mode. When Punch is set for a print job, the P: counter increments. (See SP8 064 6.)
806x-007	Other	Reserved. Not used.
806x-008	Inside-Fold	Not used
806x-009	Three-IN-Fold	Not used
806x-010	Three-OUT-Fold	Not used
806x-011	Four-Fold	Not used
806x-012	KANNON-Fold	Not used

Main SP Tables-8

806x-013	Perfect-Bind	Not used
806x-014	Ring-Bind	Not used
806x-015	3rd Vendor	

<b>8071</b>	T:Jobs/PGS	*CTL	[0 to 9999999/ 0 / 1/step]
	These SPs count the number of jobs broken down by the number of pages in the job, regardless of which application was used.		
<b>8072</b>	C:Jobs/PGS	*CTL	[0 to 9999999/ 0 / 1/step]
	These SPs count and calculate the number of copy jobs by size based on the number of pages in the job.		
<b>8073</b>	F:Jobs/PGS	*CTL	[0 to 9999999/ 0 / 1/step]
	These SPs count and calculate the number of fax jobs by size based on the number of pages in the job.		
<b>8074</b>	P:Jobs/PGS	*CTL	[0 to 9999999/ 0 / 1/step]
	These SPs count and calculate the number of print jobs by size based on the number of pages in the job.		
<b>8075</b>	S:Jobs/PGS	*CTL	[0 to 9999999/ 0 / 1/step]
	These SPs count and calculate the number of scan jobs by size based on the number of pages in the job.		
<b>8076</b>	L:Jobs/PGS	*CTL	[0 to 9999999/ 0 / 1/step]
	These SPs count and calculate the number of jobs printed from within the document server mode window at the operation panel, by the number of pages in the job.		
<b>8077</b>	O:Jobs/PGS	*CTL	[0 to 9999999/ 0 / 1/step]
	These SPs count and calculate the number of "Other" application jobs (Web Image Monitor, Palm 2, etc.) by size based on the number of pages in the job.		

Last three digits for SP8 071 to 077

807x-001	1 Page	8 07x 8	21 to 50 Pages
807x-002	2 Pages	8 07x 9	51 to 100 Pages
807x-003	3 Pages	8 07x 10	101 to 300 Pages
807x-004	4 Pages	8 07x 11	301 to 500 Pages
807x-005	5 Pages	8 07x 12	501 to 700 Pages
807x-006	6 to 10 Pages	8 07x 13	701 to 1000 Pages
807x-007	11 to 20 Pages	8 07x 14	More than 1001 Pages

- For example: When a copy job stored on the document server is printed in document server mode, the appropriate L: counter (SP8076 0xx) increments.
- Printing a fax report counts as a job and increments the F: counter (SP 8073).
- Interrupted jobs (paper jam, etc.) are counted, even though they do not finish.
- If a job is paused and re-started, it counts as one job.
- If the finisher runs out of staples during a print and staple job, then the job is counted at the time the error occurs.
- For copy jobs (SP 8072) and scan jobs (SP 8075), the total is calculated by multiplying the number of sets of copies by the number of pages scanned. (One duplex page counts as 2.)
- The first test print and subsequent test prints to adjust settings are added to the number of pages of the copy job (SP 8072).
- When printing the first page of a job from within the document server screen, the page is counted.

<b>8111</b>	T:FAX TX Jobs	*CTL	[0 to 9999999/ 0 / 1/step]
	These SPs count the total number of jobs (color or black-and-white) sent by fax, either directly or using a file stored on the document server, on a telephone line. <b>Note:</b> Color fax sending is not available at this time.		
<b>8113</b>	F: FAX TX Jobs	*CTL	[0 to 9999999/ 0 / 1/step]
	These SPs count the total number of jobs (color or black-and-white) sent by fax directly on a telephone line. <b>Note:</b> Color fax sending is not available at this time.		
811x-001	B/W		
811x-002	Color		

- These counters count jobs, not pages.
- This SP counts fax jobs sent over a telephone line with a fax application, including documents stored on the document server.
- If the mode is changed during the job, the job will count with the mode set when the job started.
- If the same document is faxed to both a public fax line and an I-Fax at a destination where both are available, then this counter increments, and the I-Fax counter (8 12x) also increments.
- The fax job is counted when the job is scanned for sending, not when the job is sent.

<b>8121</b>	T:IFAX TX Jobs	*CTL	[0 to 9999999/ 0 / 1/step]
	These SPs count the total number of jobs (color or black-and-white) sent, either directly or using a file stored on the document server, as fax images using I-Fax. <b>Note:</b> Color fax sending is not available at this time.		
<b>8123</b>	F: IFAX TX Jobs	*CTL	[0 to 9999999/ 0 / 1/step]
	These SPs count the number of jobs (color or black-and-white) sent (not stored on the document server), as fax images using I-Fax. <b>Note:</b> Color fax sending is not available at this time.		
812x-001	B/W		
812x-002	Color		

- These counters count jobs, not pages.
- The counters for color are provided for future use; the color fax feature is not available at this time.
- The fax job is counted when the job is scanned for sending, not when the job is sent.

<b>8131</b>	T:S-to-Email Jobs	*CTL	[0 to 9999999/ 0 / 1/step]
	These SPs count the total number of jobs (color or black-and-white) scanned and attached to an e-mail, regardless of whether the document server was used or not.		
<b>8135</b>	S: S-to-Email Jobs	*CTL	[0 to 9999999/ 0 / 1/step]
	These SPs count the number of jobs (color or black-and-white) scanned and attached to e-mail, without storing the original on the document server.		
813x-001	B/W		
813x-002	Color		
813x-003	ACS		

- These counters count jobs, not pages.
- If the job is stored on the document server, after the job is stored it is determined to be color or black-and-white then counted.
- If the job is cancelled during scanning, or if the job is cancelled while the document is waiting to be sent, the job is not counted.
- If the job is cancelled during sending, it may or may not be counted, depending on what stage of the process had been reached when the job was cancelled.
- If several jobs are combined for sending to the Scan Router, Scan-to-Email, or Scan-to-PC, or if one job is sent to more than one destination. each send is counted separately. For example, if the same document is sent by Scan-to-Email as well as Scan-to-PC, then it is counted twice (once for Scan-to-Email and once for Scan-to-PC).



<b>8141</b>	T:Deliv Jobs/Svr	*CTL	[0 to 9999999/ 0 / 1/step]
	These SPs count the total number of jobs (color or black-and-white) scanned and sent to a Scan Router server.		
<b>8145</b>	S: Deliv Jobs/Svr	*CTL	[0 to 9999999/ 0 / 1/step]
	These SPs count the number of jobs (color or black-and-white) scanned in scanner mode and sent to a Scan Router server.		
814x-001	B/W		
814x-002	Color		
814x-003	ACS		

- These counters count jobs, not pages.
- The jobs are counted even though the arrival and reception of the jobs at the Scan Router server cannot be confirmed.
- If even one color image is mixed with black-and-white images, then the job is counted as a "Color" job.
- If the job is cancelled during scanning, or if the job is cancelled while the document is waiting to be delivered, the job is not counted.
- If the job is cancelled during sending, it may or may not be counted, depending on what stage of the process had been reached when the job was cancelled.
- Even if several files are combined for sending, the transmission counts as one job.

<b>8151</b>	T:Deliv Jobs/PC	*CTL	[0 to 9999999/ 0 / 1/step]
	These SPs count the total number of jobs (color or black-and-white) scanned and sent to a folder on a PC (Scan-to-PC). <b>Note:</b> At the present time, 8 151 and 8 155 perform identical counts.		
<b>8155</b>	S:Deliv Jobs/PC	*CTL	[0 to 9999999/ 0 / 1/step]
	These SPs count the total number of jobs (color or black-and-white) scanned and sent with Scan-to-PC.		
815x-001	B/W		
815x-002	Color		
815x-003	ACS		

- These counters count jobs, not pages.
- If the job is cancelled during scanning, it is not counted.
- If the job is cancelled while it is waiting to be sent, the job is not counted.
- If the job is cancelled during sending, it may or may not be counted, depending on what stage of the process had been reached when the job was cancelled.
- Even if several files are combined for sending, the transmission counts as one job.

<b>8161</b>	T:PCFAX TX Jobs	*CTL	These SPs count the number of PC Fax transmission jobs. A job is counted from when it is registered for sending, not when it is sent. [0 to 9999999/ 0 / 1/step] <b>Note:</b> At the present time, these counters perform identical counts.
<b>8163</b>	F:PCFAX TX Jobs	*CTL	

- This counts fax jobs started from a PC using a PC fax application, and sending the data out to the destination from the PC through the copier.

<b>8171</b>	T:Deliv Jobs/WSD	*CTL	These SPs count the pages scanned by WS. [0 to 9999999/ 0 / 1/step]
<b>8175</b>	S:Deliv Jobs/WSD	*CTL	
001	B/W		
002	Color		
003	ACS		

<b>8181</b>	T:Scan to Media Jobs	*CTL	These SPs count the scanned pages in a media by the scanner application. [0 to 9999999/ 0 / 1/step]
<b>8185</b>	S:Scan to Media Jobs	*CTL	
001	B/W		
002	Color		
003	ACS		

<b>8191</b>	T:Total Scan PGS	*CTL	These SPs count the pages scanned by each application that uses the scanner to scan images. [0 to 9999999/ 0 / 1/step]
<b>8192</b>	C:Total Scan PGS	*CTL	
<b>8193</b>	F:Total Scan PGS	*CTL	
<b>8195</b>	S:Total Scan PGS	*CTL	
<b>8196</b>	L:Total Scan PGS	*CTL	

- SP 8 191 to 8 196 count the number of scanned sides of pages, not the number of physical pages.
- These counters do not count reading user stamp data, or reading color charts to adjust color.
- Previews done with a scanner driver are not counted.
- A count is done only after all images of a job have been scanned.
- Scans made in SP mode are not counted.

#### Examples

- If both sides of 3 A4 sheets are copied and stored to the document server using the Store File button in the Copy mode window, the C: count is 6 and the L: count is 6.
- If both sides of 3 A4 sheets are copied but not stored, the C: count is 6.
- If you enter document server mode then scan 6 pages, the L: count is 6.

<b>8201</b>	T:LSize Scan PGS A3/DLT, Larger	*CTL	[0 to 9999999/ 0 / 1/step]
	<p>These SPs count the total number of large pages input with the scanner for scan and copy jobs. Large size paper scanned for fax transmission is not counted.</p> <p><b>Note:</b> These counters are displayed in the SMC Report, and in the User Tools display.</p>		
<b>8203</b>	F: LSize Scan PGS A3/DLT, Larger	*CTL	[0 to 9999999/ 0 / 1/step]
	<p>These SPs count the total number of large pages input with the scanner for fax transmission.</p> <p><b>Note:</b> These counters are displayed in the SMC Report, and in the User Tools display.</p>		
<b>8205</b>	S:LSize Scan PGS A3/DLT, Larger	*CTL	[0 to 9999999/ 0 / 1/step]
	<p>These SPs count the total number of large pages input with the scanner for scan jobs only. Large size paper scanned for fax transmission is not counted.</p> <p><b>Note:</b> These counters are displayed in the SMC Report, and in the User Tools display.</p>		

<b>8211</b>	T:Scan PGS/LS	*CTL	<p>These SPs count the number of pages scanned into the document server</p> <p>[0 to 9999999/ - / 1/step]</p> <p>The L: counter counts the number of pages stored from within the document server mode screen at the operation panel, and with the Store File button from within the Copy mode screen.</p>
<b>8212</b>	C:Scan PGS/LS	*CTL	
<b>8213</b>	F:Scan PGS/LS	*CTL	
<b>8215</b>	S:Scan PGS/LS	*CTL	
<b>8216</b>	L:Scan PGS/LS	*CTL	

- Reading user stamp data is not counted.
- If a job is cancelled, the pages output as far as the cancellation are counted.
- If the scanner application scans and stores 3 B5 sheets and 1 A4 sheet, the S: count is 4.
- If pages are copied but not stored on the document server, these counters do not change.
- If both sides of 3 A4 sheets are copied and stored to the document server, the C: count is 6 and the L: count is 6.
- If you enter document server mode then scan 6 pages, the L: count is 6.

8221	ADF Org Feeds	*CTL	[0 to 9999999/ 0 / 1/step]
These SPs count the number of pages fed through the ADF for front and back side scanning.			
001	<p><b>Front</b></p> <p>Number of front sides fed for scanning:</p> <p>With an ADF that can scan both sides simultaneously, the Front side count is the same as the number of pages fed for either simplex or duplex scanning.</p> <p>With an ADF that cannot scan both sides simultaneously, the Front side count is the same as the number of pages fed for duplex front side scanning. (The front side is determined by which side the user loads face up.)</p>		
002	<p><b>Back</b></p> <p>Number of rear sides fed for scanning:</p> <p>With an ADF that can scan both sides simultaneously, the Back count is the same as the number of pages fed for duplex scanning.</p> <p>With an ADF that cannot scan both sides simultaneously, the Back count is the same as the number of pages fed for duplex rear-side scanning.</p>		

- When 1 sheet is fed for duplex scanning the Front count is 1 and the Back count is 1.
- If a jam occurs during the job, recovery processing is not counted to avoid double counting. Also, the pages are not counted if the jam occurs before the first sheet is output.

<b>8231</b>	Scan PGS/Mode	*CTL	[0 to 9999999/ 0 / 1/step]
	These SPs count the number of pages scanned by each ADF mode to determine the work load on the ADF.		
001	Large Volume	Selectable. Large copy jobs that cannot be loaded in the ADF at one time.	
002	SADF	Selectable. Feeding pages one by one through the ADF.	
003	Mixed Size	Selectable. Select "Mixed Sizes" on the operation panel.	
004	Custom Size	Selectable. Originals of non-standard size.	
005	Platen	Book mode. Raising the ADF and placing the original directly on the platen.	
006	Mixed 1side/ 2side	Simplex and Duplex mode.	

- If the scan mode is changed during the job, for example, if the user switches from ADF to Platen mode, the count is done for the last selected mode.
- The user cannot select mixed sizes or non-standard sizes with the fax application so if the original's page sizes are mixed or non-standard, these are not counted.
- If the user selects "Mixed Sizes" for copying in the platen mode, the Mixed Size count is enabled.
- In the SADF mode if the user copies 1 page in platen mode and then copies 2 pages with SADF, the Platen count is 1 and the SADF count is 3.

<b>8241</b>	T:Scan PGS/Org	*CTL	[0 to 9999999/ 0 / 1/step]
	These SPs count the total number of scanned pages by original type for all jobs, regardless of which application was used.		
<b>8242</b>	C:Scan PGS/Org	*CTL	[0 to 9999999/ 0 / 1/step]
	These SPs count the number of pages scanned by original type for Copy jobs.		
<b>8243</b>	F:Scan PGS/Org	*CTL	[0 to 9999999/ 0 / 1/step]
	These SPs count the number of pages scanned by original type for Fax jobs.		
<b>8245</b>	S:Scan PGS/Org	*CTL	[0 to 9999999/ 0 / 1/step]
	These SPs count the number of pages scanned by original type for Scan jobs.		
<b>8246</b>	L:Scan PGS/Org	*CTL	[0 to 9999999/ 0 / 1/step]
	These SPs count the number of pages scanned and stored from within the document server mode screen at the operation panel, and with the Store File button from within the Copy mode screen		

**Last three digits for SP8 241 to 246**

	<b>8 241</b>	<b>8 242</b>	<b>8 243</b>	<b>8 245</b>	<b>8 246</b>
824x-001: Text	Yes	Yes	Yes	Yes	Yes
824x-002: Text/Photo	Yes	Yes	Yes	Yes	Yes
824x-003: Photo	Yes	Yes	Yes	Yes	Yes
824x-004: GenCopy, Pale	Yes	Yes	No	Yes	Yes
824x-005: Map	Yes	Yes	No	No	Yes
824x-006: Normal/Detail	Yes	No	Yes	No	No
824x-007: Fine/Super Fine	Yes	No	Yes	No	No
824x-008: Binary	Yes	No	No	Yes	No
824x-009: Grayscale	Yes	No	No	Yes	No
824x-010: Color	Yes	No	No	Yes	No
824x-011: Other	Yes	Yes	Yes	Yes	Yes

- If the scan mode is changed during the job, for example, if the user switches from ADF to Platen mode, the count is done for the last selected mode.

8251	T:Scan PGS/ImgEdt	*CTL	These SPs show how many times Image Edit features have been selected at the operation panel for each application. Some examples of these editing features are: <ul style="list-style-type: none"> <li>▪ Erase → Border</li> <li>▪ Erase → Center</li> <li>▪ Image Repeat</li> <li>▪ Centering</li> <li>▪ Positive/Negative</li> </ul> [0 to 9999999/ - / 1/step] <b>Note:</b> The count totals the number of times the edit features have been used. A detailed breakdown of exactly which features have been used is not given.
8252	C:Scan PGS/ImgEdt	*CTL	
8255	S : Scan PGS/ImgEdr	*CTL	
8256	L:Scan PGS/ImgEdt	*CTL	
8257	O:Scan PGS/ImgEdt	*CTL	

The L: counter counts the number of pages stored from within the document server mode screen at the operation panel, and with the Store File button from within the Copy mode screen.

8261	T:Scn PGS/ColCr	*CTL	-
8262	C:Scn PGS/ ColCr	*CTL	-
8265	S:Scn PGS/Color	*CTL	-
8266	L:Scn PGS/ColCr	*CTL	-

Last three digits for SP8 261, 262, 265 and 266



826x-001	Color Conversion	These SPs show how many times color creation features have been selected at the operation panel.
826x-002	Color Erase	
826x-003	Background	
826x-004	Other	

<b>8281</b>	T:Scan PGS/TWAIN	*CTL	These SPs count the number of pages scanned using a TWAIN driver. These counters reveal how the TWAIN driver is used for delivery functions. [0 to 9999999/ 0 / 1/step] <b>Note:</b> At the present time, these counters perform identical counts.
<b>8285</b>	S:Scan PGS/TWAIN	*CTL	

<b>8291</b>	T:Scan PGS/Stamp	*CTL	These SPs count the number of pages stamped with the stamp in the ADF unit. [0 to 9999999/ 0 / 1/step] The L: counter counts the number of pages stored from within the document server mode screen at the operation panel, and with the Store File button from within the Copy mode screen
<b>8293</b>	F:Scan PGS/Stamp	*CTL	
<b>8295</b>	S:Scan PGS/Stamp	*CTL	

<b>8301</b>	T:Scan PGS/Size	*CTL	[0 to 9999999/ 0 / 1/step]
	These SPs count by size the total number of pages scanned by all applications. Use these totals to compare original page size (scanning) and output (printing) page size [SP 8-441].		
<b>8302</b>	C:Scan PGS/Size	*CTL	[0 to 9999999/ 0 / 1/step]
	These SPs count by size the total number of pages scanned by the Copy application. Use these totals to compare original page size (scanning) and output (printing) page size [SP 8-442].		

<b>8303</b>	F:Scan PGS/Size	*CTL	[0 to 9999999/ 0 / 1/step]
	These SPs count by size the total number of pages scanned by the Fax application. Use these totals to compare original page size (scanning) and output page size [SP 8-443].		
<b>8305</b>	S:Scan PGS/Size	*CTL	[0 to 9999999/ 0 / 1/step]
	These SPs count by size the total number of pages scanned by the Scan application. Use these totals to compare original page size (scanning) and output page size [SP 8-445].		
<b>8306</b>	L:Scan PGS/Size	*CTL	[0 to 9999999/ 0 / 1/step]
	These SPs count by size the total number of pages scanned and stored from within the document server mode screen at the operation panel, and with the Store File button from within the Copy mode screen. Use these totals to compare original page size (scanning) and output page size [SP 8-446].		

**Last three digits for SP8 301 to 306**

830x-001	A3	830x-007	LG
830x-002	A4	830x-008	LT
830x-003	A5	830x-009	HLT
830x-004	B4	830x-010	Full Bleed
830x-005	B5	830x-254	Other (Standard)
830x-006	DLT	830x-255	Other (Custom)

<b>8311</b>	T:Scan PGS/Rez	*CTL	[0 to 9999999/ 0 / 1/step]
	These SPs count by resolution setting the total number of pages scanned by applications that can specify resolution settings.		
<b>8315</b>	S: Scan PGS/Rez	*CTL	[0 to 9999999/ 0 / 1/step]
	These SPs count by resolution setting the total number of pages scanned by applications that can specify resolution settings. <b>Note:</b> At the present time, SP8-311 and SP8-315 perform identical counts.		

#### Last three digits for SP8 311 and 315

831x-001	1200 dpi
831x-002	600 dpi to 1199 dpi
831x-003	400 dpi to 599 dpi
831x-004	200 dpi to 399 dpi
831x-005	199 dpi or less

- Copy resolution settings are fixed so they are not counted.
- The Fax application does not allow finely-adjusted resolution settings so no count is done for the Fax application.

Main SP Tables-8

<b>8321</b>	T: Sacn Poster	*CTL	[0 to 9999999/ 0 / 1/step]
<b>8322</b>	C: Sacn Poster	*CTL	[0 to 9999999/ 0 / 1/step]
<b>8326</b>	L: Sacn Poster	*CTL	[0 to 9999999/ 0 / 1/step]

832x-001	2 Sheet
832x-002	4 Sheet
832x-003	9 Sheet

<b>8381</b>	T: Total PrtPGS Field Number	*CTL	<p>These SPs count the number of pages printed by the customer. The counter for the application used for storing the pages increments. [0 to 9999999/ - / 1/step]</p> <p>The L: counter counts the number of pages stored from within the document server mode screen at the operation panel. Pages stored with the Store File button from within the Copy mode screen go to the C: counter.</p>
<b>8382</b>	C: Total PrtPGS Field Number	*CTL	
<b>8383</b>	F: Total PrtPGS Field Number	*CTL	
<b>8384</b>	P: Total PrtPGS Field Number	*CTL	
<b>8385</b>	S: Total PrtPGS Field Number	*CTL	
<b>8386</b>	L: Total PrtPGS Field Number	*CTL	
<b>8387</b>	O: Total PrtPGS Field Number	*CTL	

- When several documents are merged for a print job, the number of pages stored is counted for the application that stored them.
- These counters are used primarily to calculate charges on use of the machine, so the following pages are not counted as printed pages:
  - Blank pages in a duplex printing job.

- Blank pages inserted as document covers, chapter title sheets, and slip sheets.
- Reports printed to confirm counts.
- All reports done in the service mode (service summaries, engine maintenance reports, etc.)
- Test prints for machine image adjustment.
- Error notification reports.
- Partially printed pages as the result of a copier jam.

<b>8391</b>	LSize PrtPGS		
	These SPs count pages printed on paper sizes A4/LT and larger. <b>Note:</b> In addition to being displayed in the SMC Report, these counters are also displayed in the User Tools display on the copy machine.		
001	A3/DLT, Larger	*CTL	[0 to 9999999/ 0 / 1/step]
003	BannaerPaper	*CTL	[0 to 9999999/ 0 / 1/step]

<b>8401</b>	T:PrtPGS/LS	*CTL	These SPs count the number of pages printed from the document server. The counter for the application used to print the pages is incremented. The L: counter counts the number of jobs stored from within the document server mode screen at the operation panel. [0 to 9999999/ - / 1/step]
<b>8402</b>	C:PrtPGS/LS	*CTL	
<b>8403</b>	F:PrtPGS/LS	*CTL	
<b>8404</b>	P:PrtPGS/LS	*CTL	
<b>8405</b>	S:PrtPGS/LS	*CTL	
<b>8406</b>	L:PrtPGS/LS	*CTL	

- Print jobs done with Web Image Monitor and Desk Top Binder are added to the L: count.
- Fax jobs done with Web Image Monitor and Desk Top Binder are added to the F: count.

<b>8411</b>	Prints/Duplex	*CTL	This SP counts the amount of paper (front/back counted as 1 page) used for duplex printing. Last pages printed only on one side are not counted. [0 to 9999999/ - / 1/step]
-------------	---------------	------	--

<b>8421</b>	T:PrtPGS/Dup Comb	*CTL	[0 to 9999999/ 0 / 1/step]
	These SPs count by binding and combine, and n-Up settings the number of pages processed for printing. This is the total for all applications.		
<b>8422</b>	C:PrtPGS/Dup Comb	*CTL	[0 to 9999999/ 0 / 1/step]
	These SPs count by binding and combine, and n-Up settings the number of pages processed for printing by the copier application.		
<b>8423</b>	F:PrtPGS/Dup Comb	*CTL	[0 to 9999999/ 0 / 1/step]
	These SPs count by binding and combine, and n-Up settings the number of pages processed for printing by the fax application.		
<b>8424</b>	P:PrtPGS/Dup Comb	*CTL	[0 to 9999999/ 0 / 1/step]
	These SPs count by binding and combine, and n-Up settings the number of pages processed for printing by the printer application.		
<b>8425</b>	S:PrtPGS/Dup Comb	*CTL	[0 to 9999999/ 0 / 1/step]
	These SPs count by binding and combine, and n-Up settings the number of pages processed for printing by the scanner application.		
<b>8426</b>	L:PrtPGS/Dup Comb	*CTL	[0 to 9999999/ 0 / 1/step]
	These SPs count by binding and combine, and n-Up settings the number of pages processed for printing from within the document server mode window at the operation panel.		
<b>8427</b>	O:PrtPGS/Dup Comb	*CTL	[0 to 9999999/ 0 / 1/step]
	These SPs count by binding and combine, and n-Up settings the number of pages processed for printing by Other applications		

**Last three digits for SP8 421 to 427**

842x-001	Simplex> Duplex	-
842x-002	Duplex> Duplex	-
842x-003	Book> Duplex	-
842x-004	Simplex Combine	-
842x-005	Duplex Combine	-
842x-006	2in1	2 pages on 1 side (2-Up)
842x-007	4in1	4 pages on 1 side (4-Up)
842x-008	6in1	6 pages on 1 side (6-Up)
842x-009	8in1	8 pages on 1 side (8-Up)
842x-010	9in1	9 pages on 1 side (9-Up)
842x-011	16in1	16 pages on 1 side (16-Up)
842x-012	Booklet	-
842x-013	Magazine	-
842x-014	2in1 + Booklet	-
842x-015	4in1 + Booklet	-
842x-016	6in1 + Booklet	-
842x-017	8in1 + Booklet	-
842x-018	9in1 + Booklet	-
842x-019	2in1 + Magazine	-
842x-020	4in1 + Magazine	-
842x-021	6in1 + Magazine	-
842x-022	8in1 + Magazine	-
842x-023	9in1 + Magazine	-
842x-024	16in1 + Magazine	-

Main SP Tables-8

- These counts (SP8 421 to SP8 427) are especially useful for customers who need to improve their compliance with ISO standards for the reduction of paper consumption.
- Pages that are only partially printed with the n-Up functions are counted as 1 page.
- Here is a summary of how the counters work for Booklet and Magazine modes:

Booklet			Magazine	
Original Pages	Count		Original Pages	Count
1	1		1	1
2	2		2	2
3	2		3	2
4	2		4	2
5	3		5	4
6	4		6	4
7	4		7	4
8	4		8	4

<b>8431</b>	T:PrtPGS/ImgEdt	*CTL	[0 to 9999999/ 0 / 1/step]
	These SPs count the total number of pages output with the three features below, regardless of which application was used.		
<b>8432</b>	C:PrtPGS/ImgEdt	*CTL	[0 to 9999999/ 0 / 1/step]
	These SPs count the total number of pages output with the three features below with the copy application.		
<b>8434</b>	P:PrtPGS/ImgEdt	*CTL	[0 to 9999999/ 0 / 1/step]
	These SPs count the total number of pages output with the three features below with the print application.		
<b>8436</b>	L:PrtPGS/ImgEdt	*CTL	[0 to 9999999/ 0 / 1/step]
	These SPs count the total number of pages output from within the document server mode window at the operation panel with the three features below.		



<b>8437</b>	O:PrtPGS/ImgEdt	*CTL	[0 to 9999999/ 0 / 1/step]
	These SPs count the total number of pages output with the three features below with Other applications.		

**Last three digits for SP8 431 to 437**

843x-001	Cover/Slip Sheet	Total number of covers or slip sheets inserted. The count for a cover printed on both sides counts 2.
843x-002	Series/Book	The number of pages printed in series (one side) or printed as a book with booklet right/left pagination.
843x-003	User Stamp	The number of pages printed where stamps were applied, including page numbering and date stamping.

<b>8441</b>	T:PrtPGS/Ppr Size	*CTL	[0 to 9999999/ 0 / 1/step]
	These SPs count by print paper size the number of pages printed by all applications.		
<b>8442</b>	C:PrtPGS/Ppr Size	*CTL	[0 to 9999999/ 0 / 1/step]
	These SPs count by print paper size the number of pages printed by the copy application.		
<b>8443</b>	F:PrtPGS/Ppr Size	*CTL	[0 to 9999999/ 0 / 1/step]
	These SPs count by print paper size the number of pages printed by the fax application.		
<b>8444</b>	P:PrtPGS/Ppr Size	*CTL	[0 to 9999999/ 0 / 1/step]
	These SPs count by print paper size the number of pages printed by the printer application.		
<b>8445</b>	S:PrtPGS/Ppr Size	*CTL	[0 to 9999999/ 0 / 1/step]
	These SPs count by print paper size the number of pages printed by the scanner application.		

<b>8446</b>	L:PrtPGS/Ppr Size	*CTL	[0 to 9999999/ 0 / 1/step]
	These SPs count by print paper size the number of pages printed from within the document server mode window at the operation panel.		
<b>8447</b>	O:PrtPGS/Ppr Size	*CTL	[0 to 9999999/ 0 / 1/step]
	These SPs count by print paper size the number of pages printed by Other applications.		

**Last three digits for SP8 441 to 447**

844x-001	A3
844x-002	A4
844x-003	A5
844x-004	B4
844x-005	B5
844x-006	DLT
844x-007	LG
844x-008	LT
844x-009	HLT
844x-010	Full Bleed
844x-254	Other (Standard)
844x-255	Other (Custom)

- These counters do not distinguish between LEF and SEF.

<b>8451</b>	PrtPGS/Ppr Tray	*CTL	[0 to 9999999/ 0 / 1/step]
	These SPs count the number of sheets fed from each paper feed station.		
001	Bypass Tray	Bypass Tray	
002	Tray 1	Machine	
003	Tray 2	Paper Tray Unit (Option)	
004	Tray 3	Paper Tray Unit (Option)	
005	Tray 4	Paper Tray Unit (Option)	
006	Tray 5	Not used	
007	Tray 6	Not used	
008	Tray 7	Not used	
009	Tray 8	Not used	
010	Tray 9	Not used	
011	Tray10	Not used	
012	Tray11	Not used	
013	Tray12	Not used	
014	Tray13	Not used	
015	Tray14	Not used	
016	Tray15	Not used	

<b>8461</b>	T:PrtPGS/Ppr Type	*CTL	[0 to 9999999/ 0 / 1/step]
	<p>These SPs count by paper type the number pages printed by all applications.</p> <ul style="list-style-type: none"> <li>▪ These counters are not the same as the PM counter. The PM counter is based on feed timing to accurately measure the service life of the feed rollers. However, these counts are based on output timing.</li> <li>▪ Blank sheets (covers, chapter covers, slip sheets) are also counted.</li> <li>▪ During duplex printing, pages printed on both sides count as 1, and a page printed on one side counts as 1.</li> </ul>		
<b>8462</b>	C:PrtPGS/Ppr Type	*CTL	[0 to 9999999/ 0 / 1/step]
	<p>These SPs count by paper type the number pages printed by the copy application.</p>		
<b>8463</b>	F:PrtPGS/Ppr Type	*CTL	[0 to 9999999/ 0 / 1/step]
	<p>These SPs count by paper type the number pages printed by the fax application.</p>		
<b>8464</b>	P:PrtPGS/Ppr Type	*CTL	[0 to 9999999/ 0 / 1/step]
	<p>These SPs count by paper type the number pages printed by the printer application.</p>		
<b>8466</b>	L:PrtPGS/Ppr Type	*CTL	[0 to 9999999/ 0 / 1/step]
	<p>These SPs count by paper type the number pages printed from within the document server mode window at the operation panel.</p>		

**Last three digits for SP8 461 to 466**

846x-001	Normal
846x-002	Recycled
846x-003	Special
846x-004	Thick
846x-005	Normal (Back)
846x-006	Thick (Back)
846x-007	OHP
846x-008	Other

<b>8471</b>	PrtPGS/Mag	*CTL	[0 to 9999999/ 0 / 1/step]
	These SPs count by magnification rate the number of pages printed.		
001	49% or less		
002	50% to 99%		
003	100%		
004	101% to 200%		
005	201% or more		

- Counts are done for magnification adjusted for pages, not only on the operation panel but performed remotely with an external network application capable of performing magnification adjustment as well.
- Magnification adjustments done with printer drivers with PC applications such as Excel are also counted.
- Magnification adjustments done for adjustments after they have been stored on the document server are not counted.
- Magnification adjustments performed automatically during Auto Reduce/Enlarge copying are counted.
- The magnification rates of blank cover sheets, slip sheets, etc. are automatically assigned a rate of 100%.

<b>8481</b>	T:PrtPGS/TonSave	*CTL	[0 to 9999999/ 0 / 1/step]
<b>8484</b>	P:PrtPGS/TonSave	*CTL	[0 to 9999999/ 0 / 1/step]
	These SPs count the number of pages printed with the Toner Save feature switched on. <b>Note:</b> These SPs return the same results as this SP is limited to the Print application.		

<b>8491</b>	T:PrtPGS/Col Mode	*CTL	These SPs count the number of pages printed in the Color Mode by each application.
<b>8492</b>	C:PrtPGS/Col Mode	*CTL	
<b>8493</b>	F:PrtPGS/Col Mode	*CTL	
<b>8496</b>	L:PrtPGS/Col Mode	*CTL	
<b>8497</b>	O:PrtPGS/Col Mode	*CTL	

**Last three digits for SP8 491 to 493, 496 and 497**

849x-001	B/W
849x-002	Single Color
849x-003	Two Color
849x-004	Full Color
849x-051	B/W(Banner)
849x-052	Single Color(Banner)
849x-053	Two Color(Banner)
849x-054	Full Color(Banner)

<b>8501</b>	T:PrtPGS/Col Mode	*CTL	These SPs count the number of pages printed in the Color Mode by the print application.
<b>8504</b>	P:PrtPGS/Col Mode	*CTL	
<b>8507</b>	O:PrtPGS/Col Mode	*CTL	

**Last three digits for SP8 501, 504 and 507**

850x-001	B/W
850x-002	Mono Color
850x-003	Full Color
850x-004	Single Color
850x-005	Two Color
850x-051	B/W(Banner)
850x-052	Full Color(Banner)
850x-053	Single Color(Banner)
850x-054	Two Color(Banner)

<b>8511</b>	T:PrtPGS/Emul	*CTL	[0 to 9999999/ 0 / 1/step]
	These SPs count by printer emulation mode the total number of pages printed.		
<b>8514</b>	P:PrtPGS/Emul	*CTL	[0 to 9999999/ 0 / 1/step]
	These SPs count by printer emulation mode the total number of pages printed.		

**Last three digits for SP8 511 and 514**

851x-001	RPCS	-
851x-002	RPDL	-
851x-003	PS3	-
851x-004	R98	-
851x-005	R16	-
851x-006	GL/GL2	-
851x-007	R55	-
851x-008	RTIFF	-
851x-009	PDF	-
851x-010	PCL5e/5c	-
851x-011	PCL XL	-
851x-012	IPDL-C	-
851x-013	BM-Links	Japan Only
851x-014	Other	-
851x-015	IPDS	-
851x-016	XPS	-

- SP8 511 and SP8 514 return the same results as they are both limited to the Print application.
- Print jobs output to the document server are not counted.

<b>8521</b>	T:PrtPGS/FIN	*CTL	[0 to 9999999 / 0 / 1/step]
	These SPs count by finishing mode the total number of pages printed by all applications.		
<b>8522</b>	C:PrtPGS/FIN	*CTL	[0 to 9999999 / 0 / 1/step]
	These SPs count by finishing mode the total number of pages printed by the Copy application.		
<b>8523</b>	F:PrtPGS/FIN	*CTL	[0 to 9999999 / 0 / 1/step]
	These SPs count by finishing mode the total number of pages printed by the Fax application. <b>Note:</b> Print finishing options for received faxes are currently not available.		
<b>8524</b>	P:PrtPGS/FIN	*CTL	[0 to 9999999 / 0 / 1/step]
	These SPs count by finishing mode the total number of pages printed by the Print application.		
<b>8525</b>	S:PrtPGS/FIN	*CTL	[0 to 9999999 / 0 / 1/step]
	These SPs count by finishing mode the total number of pages printed by the Scanner application.		
<b>8526</b>	L:PrtPGS/FIN	*CTL	[0 to 9999999 / 0 / 1/step]
	These SPs count by finishing mode the total number of pages printed from within the document server mode window at the operation panel.		

**Last three digits for SP8 521 to 526**

852x-001	Sort	852x-009	Three-IN-Fold
852x-002	Stack	852x-010	Three-OUT-Fold
852x-003	Staple	852x-011	Four-Fold
852x-004	Booklet	852x-012	KANNON-Fold
852x-005	Z-Fold	852x-013	Perfect-Bind
852x-006	Punch	852x-014	Ring-Bind
852x-007	Other	852x-015	3rd Vendor
852x-008	Inside-Fold		



 **Note**

- If stapling is selected for finishing and the stack is too large for stapling, the unstapled pages are still counted.
- The counts for staple finishing are based on output to the staple tray, so jam recoveries are counted.

<b>8531</b>	Staples		
	This SP counts the amount of staples used (-001) or count stapled (-002) by the machine.		
001	Staples	*CTL	[0 to 9999999 / - / 1]
002	Stapleless	*CTL	[0 to 9999999 / - / 1]

<b>8551</b>	T:PrtBooks/FIN	*CTL	-
<b>8552</b>	C:PrtBooks/FIN	*CTL	-
<b>8554</b>	P:PrtBooks/FIN	*CTL	-
<b>8556</b>	L:PrtBooks/FIN	*CTL	-
855x-001	Perfect-Bind	Not used	
855x-002	Ring-Bind	Not used	

<b>8561</b>	T:A Sheet Of Paper	*CTL	[0 to 9999999 / <b>0</b> / 1/step]
<b>8562</b>	C:A Sheet Of Paper	*CTL	[0 to 9999999 / <b>0</b> / 1/step]
<b>8563</b>	F:A Sheet Of Paper	*CTL	[0 to 9999999 / <b>0</b> / 1/step]
<b>8564</b>	P:A Sheet Of Paper	*CTL	[0 to 9999999 / <b>0</b> / 1/step]
<b>8566</b>	L:A Sheet Of Paper	*CTL	[0 to 9999999 / <b>0</b> / 1/step]
<b>8567</b>	O:A Sheet Of Paper	*CTL	[0 to 9999999 / <b>0</b> / 1/step]

**Last three digits for SP8 561 to 567**

856x-001	Total: Over A3/DLT
856x-002	Total: Under A3/DLT

Main SP Tables-8

856x-003	Duplex: Over A3/DLT
856x-004	Duplex: Under A3/DLT

<b>8581</b>	T:Counter	*CTL	[0 to 9999999 / 0 / 1/step]
	These SPs count the total output broken down by color output, regardless of the application used. In addition to being displayed in the SMC Report, these counters are also displayed in the User Tools display on the copy machine.		
001	Total		
002	Total: Full Color		
003	B&W/Single Color		
004	Development: CMY		
005	Development: K		
006	Copy: Color		
007	Copy: B/W		
008	Print: Color		
009	Print: B/W		
010	Total: Color		
011	Total: B/W		
012	Full Color: A3		
013	Full Color: B4 JIS or Smaller		
014	Full Color Print		
015	Mono Color Print		
016	Full Color GPC		
017	Twin Color Mode Print		
018	Full Color Print(Twin)		

019	Mono Color Print(Twin)
020	Full Color Total(CV)
021	Mono Color Total(CV)
022	Full Color Print(CV)
028	Development: CMY(A3)
029	Development: K(A3)
030	Total: Color(A3)
031	Total: B/W(A3)

<b>8582</b>	C:Counter	*CTL	[0 to 9999999/ 0 / 1/step]
	These SPs count the total output of the copy application broken down by color output.		
001	B/W		
002	Single Color		
003	Two Color		
004	Full Color		

<b>8583</b>	F:Counter	*CTL	[0 to 9999999/ 0 / 1/step]
	These SPs count the total output of the fax application broken down by color output.		
001	B/W		
002	Single Color		

<b>8584</b>	P:Counter	*CTL	[0 to 9999999/ 0 / 1/step]
	These SPs count the total output of the print application broken down by color output.		
001	B/W		

Main SP Tables-8

002	Mono Color
003	Full Color
004	Single Color
005	Two Color

<b>8586</b>	L:Counter	*CTL	[0 to 9999999/ 0 / 1/step]
	These SPs count the total output of the local storage broken down by color output.		
001	B/W		
002	Single Color		
003	Two Color		
004	Full Color		

<b>8591</b>	O:Counter	*CTL	[0 to 9999999/ 0 / 1/step]
	These SPs count the totals for A3/DLT paper use, number of duplex pages printed, and the number of staples used. These totals are for Other (O:) applications only.		
001	A3/DLT		
002	Duplex		
005	Banner		

<b>8601</b>	T:Coverage Counter	*CTL	[0 to 9999999/ 0 / 1/step]
	These SPs count the total coverage for each color and the total printout pages for each printing mode.		
001	B/W		
002	Color		
011	B/W Printing Pages		
012	Color Printing Pages		

021	Coverage Counter 1
022	Coverage Counter 2
023	Coverage Counter 3
031	Coverage Counter 1 (YMC)
032	Coverage Counter 2 (YMC)
033	Coverage Counter 3 (YMC)

<b>8602</b>	C:Coverage Counter	*CTL	[0 to 2147483647/ 0 / 1%/step]
	These SPs count the total coverage for each color and the total printout pages for each printing mode.		
<b>8603</b>	F:Coverage Counter	*CTL	[0 to 2147483647/ 0 / 1%/step]
	These SPs count the total coverage for each color and the total printout pages for each printing mode.		
<b>8604</b>	P:Coverage Counter	*CTL	[0 to 2147483647/ 0 / 1%/step]
	These SPs count the total coverage for each color and the total printout pages for each printing mode.		
<b>8606</b>	L:Coverage Counter	*CTL	[0 to 2147483647/ 0 / 1%/step]
	These SPs count the total coverage for each color and the total printout pages for each printing mode.		

**Last three digits for SP8 602 to 606**

	<b>8 602</b>	<b>8 603</b>	<b>8 604</b>	<b>8 606</b>
860x-001: B/W	Yes	Yes	Yes	Yes
860x-002: Single Color	Yes	Yes	Yes	Yes
860x-003: Two Color	Yes	No	Yes	Yes
860x-004: Full Color	Yes	No	Yes	Yes

Main SP Tables-8

<b>8617</b>	SDK Apli Counter	*CTL	[0 to 9999999/ 0 / 1/step]
	These SPs count the total printout pages for each SDK applicaion.		
001	SDK-1		
002	SDK-2		
003	SDK-3		
004	SDK-4		
005	SDK-5		
006	SDK-6		
007	SDK-7		
008	SDK-8		
009	SDK-9		
010	SDK-10		
011	SDK-11		
012	SDK-12		

<b>8621</b>	Func Use Counter <b>DFU</b>		
001 to 064	Function 001 to Function 064		

<b>8631</b>	T:FAX TX PGS	*CTL	[0 to 9999999/ 0 / 1/step]
	These SPs count by color mode the number of pages sent by fax to a telephone number.		
<b>8633</b>	F:FAX TX PGS	*CTL	[0 to 9999999/ 0 / 1/step]
	These SPs count by color mode the number of pages sent by fax to a telephone number.		
863x-001	B/W		
863x-002	Color		

- If a document has color and black-and-white pages mixed, the pages are counted separately as B/W or Color.
- At the present time, this feature is provided for the Fax application only so SP8631 and SP8633 are the same.
- The counts include error pages.
- If a document is sent to more than one destination with a Group transmission, the count is done for each destination.
- Polling transmissions are counted but polling RX are not.
- Relay, memory, and confidential mailbox transmissions and are counted for each destination.

<b>8641</b>	T:IFAX TX PGS	*CTL	[0 to 9999999/ 0 / 1/step]
	These SPs count by color mode the number of pages sent by fax to as fax images using I-Fax.		
<b>8643</b>	F:IFAX TX PGS	*CTL	[0 to 9999999/ 0 / 1/step]
	These SPs count by color mode the number of pages sent by Fax as fax images using I-Fax.		
864x-001	B/W		
864x-002	Color		

- If a document has color and black-and-white pages mixed, the pages are counted separately as B/W or Color.
- At the present time, this feature is provided for the Fax application only so SP8641 and SP8643 are the same.
- The counts include error pages.
- If a document is sent to more than one destination with a Group transmission, the count is done for each destination.
- Polling transmissions are counted but polling RX are not.
- Relay, memory, and confidential mailbox transmissions and are counted for each destination.

<b>8651</b>	T:S-to-Email PGS	*CTL	[0 to 9999999/ 0 / 1/step]
	These SPs count by color mode the total number of pages attached to an e-mail for both the Scan and document server applications.		
<b>8655</b>	S:S-to-Email PGS	*CTL	[0 to 9999999/ 0 / 1/step]
	These SPs count by color mode the total number of pages attached to an e-mail for the Scan application only.		
865x-001	B/W		
865x-002	Color		

 **Note**

- The count for B/W and Color pages is done after the document is stored on the HDD. If the job is cancelled before it is stored, the pages are not counted.
- If Scan-to-Email is used to send a 10-page document to 5 addresses, the count is 10 (the pages are sent to the same SMTP server together).
- If Scan-to-PC is used to send a 10-page document to 5 folders, the count is 50 (the document is sent to each destination of the SMB/FTP server).
- Due to restrictions on some devices, if Scan-to-Email is used to send a 10-page document to a large number of destinations, the count may be divided and counted separately. For example, if a 10-page document is sent to 200 addresses, the count is 10 for the first 100 destinations and the count is also 10 for the second 100 destinations, for a total of 20.).



<b>8661</b>	T:Deliv PGS/Svr	*CTL	[0 to 9999999/ 0 / 1/step]
	These SPs count by color mode the total number of pages sent to a Scan Router server by both Scan and LS applications.		
<b>8665</b>	S:Deliv PGS/Svr	*CTL	[0 to 9999999/ 0 / 1/step]
	These SPs count by color mode the total number of pages sent to a Scan Router server by the Scan application.		
866x-001	B/W		
866x-002	Color		

 **Note**

- The B/W and Color counts are done after the document is stored on the HDD of the Scan Router server.
- If the job is canceled before storage on the Scan Router server finishes, the counts are not done.
- The count is executed even if regardless of confirmation of the arrival at the Scan Router server.

<b>8671</b>	T:Deliv PGS/PC	*CTL	[0 to 9999999/ 0 / 1/step]
	These SPs count by color mode the total number of pages sent to a folder on a PC (Scan-to-PC) with the Scan and LS applications.		
<b>8675</b>	S: Deliv PGS/PC	*CTL	[0 to 9999999/ 0 / 1/step]
	These SPs count by color mode the total number of pages sent with Scan-to-PC with the Scan application.		
867x-001	B/W		
867x-002	Color		

<b>8681</b>	T:PCFAX TXPGS	*CTL	These SPs count the number of pages sent by PC Fax. These SPs are provided for the Fax application only, so the counts for SP8 681 and SP8 683 are the same. [0 to 9999999/ 0 / 1/step]
<b>8683</b>	F:PCFAX TXPGS	*CTL	

- This counts pages sent from a PC using a PC fax application, from the PC through the copier to the destination.
- When sending the same message to more than one place using broadcasting, the pages are only counted once. (For example, a 10-page fax is sent to location A and location B. The counter goes up by 10, not 20.)

<b>8691</b>	T:TX PGS/LS	*CTL	These SPs count the number of pages sent from the document server. The counter for the application that was used to store the pages is incremented. [0 to 9999999/ 0 / 1/step] The L: counter counts the number of pages stored from within the document server mode screen at the operation panel. Pages stored with the Store File button from within the Copy mode screen go to the C: counter.
<b>8692</b>	C:TX PGS/LS	*CTL	
<b>8693</b>	F:TX PGS/LS	*CTL	
<b>8694</b>	P:TX PGS/LS	*CTL	
<b>8695</b>	S:TX PGS/LS	*CTL	
<b>8696</b>	L:TX PGS/LS	*CTL	

 **Note**

- Print jobs done with Web Image Monitor and Desk Top Binder are added to the count.
- If several documents are merged for sending, the number of pages stored are counted for the application that stored them.
- When several documents are sent by a Fax broadcast, the F: count is done for the number of pages sent to each destination.

<b>8701</b>	TX PGS/Port	*CTL	[0 to 9999999/ 0 / 1/step]
	These SPs count the number of pages sent by the physical port used to send them. For example, if a 3-page original is sent to 4 destinations via ISDN G4, the count for ISDN (G3, G4) is 12.		
001	PSTN-1		
002	PSTN-2		
003	PSTN-3		
004	ISDN (G3,G4)		
005	Network		

<b>8711</b>	T:Scan PGS/Comp	*CTL	[0 to 9999999/ 0 / 1/step]
<b>8715</b>	S:Scan PGS/Comp	*CTL	[0 to 9999999/ 0 / 1/step]
	These SPs count the number of pages sent by each compression mode.		
871x-001	JPEG/JPEG2000		
871x-002	TIFF(Multi/Single)		
871x-003	PDF		
871x-004	Other		
871x-005	PDF/Comp		
871x-006	PDF/A		
871x-007	PDF(OCR)		
871x-008	PDF/Comp(OCR)		
871x-009	PDF/A(OCR)		

Main SP Tables-8

<b>8721</b>	T: Deliv PGS/WSD	*CTL	[0 to 9999999/ 0 / 1/step]
<b>8725</b>	S: Deliv PGS/WSD	*CTL	
	These SPs count the number of pages scanned by each scanner mode.		
872x-001	B/W		
872x-002	Color		

<b>8731</b>	T:Scan PGS/Media	*CTL	[0 to 9999999/ 0 / 1/step]
<b>8735</b>	S:Scan PGS/Media	*CTL	
	These SPs count the number of pages scanned and saved in a meia by each scanner mode.		
873x-001	B/W		
873x-002	Color		

<b>8741</b>	RX PGS/Port	*CTL	[0 to 9999999/ 0 / 1/step]
	These SPs count the number of pages received by the physical port used to receive them.		
001	PSTN-1		
002	PSTN-2		
003	PSTN-3		
004	ISDN (G3,G4)		
005	Network		

8 771	Dev Counter	*CTL	[0 to 9999999/ 0 / 1/step]
	These SPs count the frequency of use (number of rotations of the development rollers) for black and other color toners.		
8 771-001	Total		
8 771-002	K		
8 771-003	Y		
8 771-004	M		
8 771-005	C		

8 781	Toner_Botol_Info.	*CTL	[0 to 9999999/ 0 / 1/step]
	These SPs display the number of already replaced toner bottles. <b>Note:</b> Currently, the data in SP7-833-011 through 014 and the data in SP8-781-001 through 004 are the same.		
8 781-001	BK	The number of black-toner bottles	
8 781-002	Y	The number of yellow-toner bottles	
8 781-003	M	The number of magenta-toner bottles	
8 781-004	C	The number of cyan-toner bottles	

8791	LS Memory Remain	*CTL	[0 to 100 / 0 / 1/step]
	This SP displays the percent of space available on the document server for storing documents.		

8801	Toner Remain	*CTL	[0 to 100/ 0 / 1/step]
	These SPs display the percent of toner remaining for each color. This SP allows the user to check the toner supply at any time. <b>Note:</b> This precise method of measuring remaining toner supply (1% steps) is better than other machines in the market that can only measure in increments of 10 (10% steps).		
001	K		

Main SP Tables-8

002	Y
003	M
004	C

8811	Eco Counter		
001	Eco Total	*CTL	[0 to 9999999 / 0 / 1/step]
	Displays the number of pages reduced by using the color, full color, duplex and combine function.		
002	Color	*CTL	[0 to 9999999 / 0 / 1/step]
	Displays the number of pages reduced by using the color function.		
003	Full Color	*CTL	[0 to 9999999 / 0 / 1/step]
	Displays the number of pages reduced by using the full color function		
004	Duplex	*CTL	[0 to 9999999 / 0 / 1/step]
	Displays the number of pages reduced by using the duplex function.		
005	Combine	*CTL	[0 to 9999999 / 0 / 1/step]
	Displays the number of pages reduced by using the combine function.		
006	Color(%)	*CTL	[0 to 100/ 0 / 1%/step]
	Displays the utilization ratio of the color function.		
007	Full Color(%)	*CTL	[0 to 100/ 0 / 1%/step]
	Displays the utilization ratio of the full color function.		
008	Duplex(%)	*CTL	[0 to 100/ 0 / 1%/step]
	Displays the utilization ratio of the duplex function.		
009	Combine(%)	*CTL	[0 to 100/ 0 / 1%/step]
	Displays the utilization ratio of the combine function.		
010	Paper Cut(%)	*CTL	[0 to 100/ 0 / 1%/step]
	Displays the paper reduction ratio.		

051	Sync Eco Total	*CTL	[0 to 99999999/ 0 / 1/step]
	-		
052	Sync Color	*CTL	[0 to 99999999/ 0 / 1/step]
	-		
053	Sync Full Color	*CTL	[0 to 99999999/ 0 / 1/step]
054	Sync Duplex	*CTL	[0 to 99999999/ 0 / 1/step]
055	Sync Combine	*CTL	[0 to 99999999/ 0 / 1/step]
056	Sync Color(%)	*CTL	[0 to 100/ 0 / 1%/step]
057	Sync Full Color(%)	*CTL	[0 to 100/ 0 / 1%/step]
058	Sync Duplex(%)	*CTL	[0 to 100/ 0 / 1%/step]
059	Sync Combine(%)	*CTL	[0 to 100/ 0 / 1%/step]
060	Sync Paper Cut(%)	*CTL	[0 to 100/ 0 / 1%/step]
101	Eco Totalr>Last	*CTL	[0 to 9999999 / 0 / 1/step]
	-		
102	Color>Last	*CTL	[0 to 9999999 / 0 / 1/step]
	-		
103	Full Color>Last	*CTL	[0 to 9999999 / 0 / 1/step]
	-		
104	Duplex>Last	*CTL	[0 to 9999999 / 0 / 1/step]
	-		
105	Combine>Last	*CTL	[0 to 9999999 / 0 / 1/step]
	-		
106	Color(%)Last	*CTL	[0 to 100/ 0 / 1%/step]
	-		
107	Full Color(%)Last	*CTL	[0 to 100/ 0 / 1%/step]
	-		

Main SP Tables-8

108	Duplex(%):Last	*CTL	[0 to 100/ 0 / 1%/step]
	-		
109	Combine(%):Last	*CTL	[0 to 100/ 0 / 1%/step]
	-		
110	Paper Cut(%):Last	*CTL	[0 to 100/ 0 / 1%/step]
	-		
151	Sync Eco Totalr:Last	*CTL	[0 to 9999999 / 0 / 1/step]
	-		
152	Sync Color:Last	*CTL	[0 to 9999999 / 0 / 1/step]
	-		
153	Sync Full Color:Last	*CTL	[0 to 9999999 / 0 / 1/step]
	-		
154	Sync Duplex:Last	*CTL	[0 to 9999999 / 0 / 1/step]
	-		
155	Sync Combine:Last	*CTL	[0 to 9999999 / 0 / 1/step]
	-		
156	Sync Color(%):Last	*CTL	[0 to 100/ 0 / 1%/step]
	-		
157	Sync Full Color(%):Last	*CTL	[0 to 100/ 0 / 1%/step]
	-		
158	Sync Duplex(%):Last	*CTL	[0 to 100/ 0 / 1%/step]
	-		
159	Sync Combine(%):Last	*CTL	[0 to 100/ 0 / 1%/step]
	-		
160	Sync Paper Cut(%):Last	*CTL	[0 to 100/ 0 / 1%/step]
	-		



<b>8851</b>	CVr Cnt: 0-10%	*CTL	[0 to 9999999/ 0 / 1/step]
	These SPs display the number of scanned sheets on which the coverage of each color is from 0% to 10%.		
011	0 to 2%: BK	031	5 to 7%: BK
012	0 to 2%: Y	032	5 to 7%: Y
013	0 to 2%: M	033	5 to 7%: M
014	0 to 2%: C	034	5 to 7%: C
021	3 to 4%: BK	041	8 to 10%: BK
022	3 to 4%: Y	042	8 to 10%: Y
023	3 to 4%: M	043	8 to 10%: M
024	3 to 4%: C	044	8 to 10%: C

<b>8861</b>	CVr Cnt: 11-20%	*CTL	[0 to 9999999/ 0 / 1/step]
	These SPs display the number of scanned sheets on which the coverage of each color is from 11% to 20%.		
001	BK		
002	Y		
003	M		
004	C		

<b>8871</b>	CVr Cnt: 21-30%	*CTL	[0 to 9999999/ 0 / 1/step]
	These SPs display the number of scanned sheets on which the coverage of each color is from 21% to 30%.		
001	BK		
002	Y		
003	M		
004	C		

Main SP Tables-8

<b>8881</b>	CVr Cnt: 31%-	*CTL	[0 to 9999999/ 0 / 1/step]
	These SPs display the number of scanned sheets on which the coverage of each color is 31% or higher.		
001	BK		
002	Y		
003	M		
004	C		

<b>8891</b>	Page/Toner Bottle	*CTL	[0 to 9999999/ 0 / 1/step]
	These SPs display the amount of the remaining current toner for each color.		
001	BK		
002	Y		
003	M		
004	C		

<b>8901</b>	Page/Toner_Prev1	*CTL	[0 to 9999999/ 0 / 1/step]
	These SPs display the amount of the remaining previous toner for each color.		
001	BK		
002	Y		
003	M		
004	C		

<b>8911</b>	Page/Toner_Prev2	*CTL	[0 to 9999999/ 0 / 1/step]
	These SPs display the amount of the remaining 2nd previous toner for each color.		
001	BK		
002	Y		
003	M		
004	C		

<b>8921</b>	Cvr Cnt/Total	*CTL	[0 to 2147483647/ 0 / 1/step]
	Displays the total coverage and total printout number for each color.		
001	Coverage (%) BK		
002	Coverage (%) Y		
003	Coverage (%) M		
004	Coverage (%) C		
<b>8921</b>	Cvr Cnt/Total	*CTL	[0 to 9999999/ 0 / 1/step]
011	Coverage /P: BK		
012	Coverage /P: Y		
013	Coverage /P: M		
014	Coverage /P: C		

<b>8941</b>	Machine Status	*CTL	[0 to 9999999/ 0 / 1/step]
	These SPs count the amount of time the machine spends in each operation mode. These SPs are useful for customers who need to investigate machine operation for improvement in their compliance with ISO Standards.		
001	Operation Time	Engine operation time. Does not include time while controller is saving data to HDD (while engine is not operating).	
002	Standby Time	Engine not operating. Includes time while controller saves data to HDD. Does not include time spent in Energy Save, Low Power, or Off modes.	
003	Energy Save Time	Includes time while the machine is performing background printing.	
004	Low Power Time	Includes time in Energy Save mode with Engine on. Includes time while machine is performing background printing.	
005	Off Mode Time	Includes time while machine is performing background printing. Does not include time machine remains powered off with the power switches.	
006	SC	Total time when SC errors have been staying.	
007	PrtJam	Total time when paper jams have been staying during printing.	
008	OrgJam	Total time when original jams have been staying during scanning.	
009	Supply PM Unit End	Total time when toner end has been staying.	

<b>8951</b>	AddBook Register	*CTL	-
	These SPs count the number of events when the machine manages data registration.		
001	User Code /User ID	User code registrations.	[0 to 99999/ 0 / 1/step]
002	Mail Address	Mail address registrations.	
003	Fax Destination	Fax destination registrations.	
004	Group	Group destination registrations.	
005	Transfer Request	Fax relay destination registrations for relay TX.	
006	F-Code	F-Code box registrations.	
007	Copy Program	Copy application registrations with the Program (job settings) feature.	[0 to 255 / 0 / 1/step]
008	Fax Program	Fax application registrations with the Program (job settings) feature.	
009	Printer Program	Printer application registrations with the Program (job settings) feature.	
010	Scanner Program	Scanner application registrations with the Program (job settings) feature.	

Main SP Tables-8

<b>8961</b>	Electricity Status	*CTL	[0 to 9999999/ 0 / 1/step]
	-		
001	Ctrl Standby Time		
002	STR Time		
003	Main Power Off Time		
004	Reading and Printing Time		
005	Printing Time		
006	Reading Time		
007	Eng Waiting Time		
008	Low Power State Time		
009	Silent State Time		
010	Heater Off State Time		
011	LCD on Time		
101	Silent Print		

<b>8971</b>	Unit Control	*CTL	[0 to 99999999/ 0 / 1/step]
	-		
001	Engine Off Recovery Count		
002	Power Off Count		
003	Force Power Off Count		

<b>8999</b>	Admin. Counter List		
	Displays the total coverage and total printout number for each color.		
001	Total	*CTL	[0 to 9999999/ - / 1]
002	Copy: Full Color	*CTL	
003	Copy: BW	*CTL	
004	Copy: Single Color	*CTL	
005	Copy: Two Color	*CTL	
006	Printer Full Color	*CTL	
007	Printer BW	*CTL	
008	Printer Single Color	*CTL	
009	Printer Two Color	*CTL	
010	Fax Print: BW	*CTL	
011	Fax Print: Single Color	*CTL	
013	Duplex	*CTL	
022	Copy: Full Color(%)	*CTL	
023	Copy: BW(%)	*CTL	
024	Copy: Single Color(%)	*CTL	
025	Copy: Two Color(%)	*CTL	
026	Printer: Full Color(%)	*CTL	
027	Printer: BW(%)	*CTL	
028	Printer: Single Color(%)	*CTL	
029	Printer: Two Color(%)	*CTL	
030	Fax Print: BW(%)	*CTL	
031	Fax Print: Single Color(%)	*CTL	

Main SP Tables-8

101	Transmission Total: Color	*CTL	[0 to 9999999/ - / 1]
102	Transmission Total: BW	*CTL	
102	Transmission Total: BW	*CTL	
103	FAX Transmission	*CTL	
104	Scanner Transmission: Color	*CTL	
105	Scanner Transmission: BW	*CTL	



## 3.12 PRINTER SERVICE MODE

### 3.12.1 PRINTER SERVICE MODE

1001	Bit Switch			
001	Bit Switch 1		0	1
	bit 0	<b>DFU</b>	-	-
	bit 1	<b>Responding with the hostname as the sysName</b>	Model name (PnP name)	Hostname
		This BitSwitch can change the value of the sysName. 0 (default): Model name (PnP name) such as "MP C401SP" 1: Host name		
	bit 2	<b>DFU</b>	-	-
	bit 3	<b>No I/O Timeout</b>	0:Disabled	1:Enabled
		Enables/Disables MFP I/O Timeouts. If enabled, the MFP I/O Timeout setting will have no affect. I/O Timeouts will never occur.		
	bit 4	<b>SD Card Save Mode</b>	0:Disabled	1:Enabled
		If this bit switch is enabled, print jobs will be saved to the GW SD slot and not output to paper.		
	bit 5	<b>[PS and PDF] Paper size error margin</b>	±5pt	±10pt
		When a PS job is printed by using a custom paper size, the job might not be printed because of a paper size mismatch caused by a calculation error. By default, the error margin for matching to a paper size is ±5 points. By enabling this BitSwitch, the error margin for matching to a paper size can be extended to ±10 points.		
	bit 6	<b>Not used</b>	-	-
	bit 7	<b>[RPCS,PCL]: Printable area frame border</b>	0: Disable	1: Enable
		Prints all RPCS and PCL jobs with a border around the printable area.		

1001	Bit Switch			
002	Bit Switch 2		0	1
	bit 0	<b>Not used</b>	-	-
	bi 1	<b>DFU</b>	-	-
	bit 2	<b>Applying a Collate Type</b>	Shift Collate	Normal Collate
	<p>A collate type (shift or normal) will be applied to all jobs that do not explicitly define a collate type.</p> <p>Note: If #5-0 is enabled, this BitSwitch has no effect.</p>			
	bit 3	<b>[PCL5e/c.PS]: PDL Auto Switching</b>	0: Enabled	1: Disabled
	<p>Enables/disable the MFPs ability to change the PDL processor mid-job. Some host systems submit jobs that contain both PS and PCL5e/c. If Auto PDL switching is disabled, these jobs will not be printed properly.</p>			
	bit 4	<b>Not used</b>	-	-
	bit 5	<b>DFU</b>	-	-
	bit 6	<b>Not used</b>	-	-
	bit 7	<b>DFU</b>	-	-

1001	Bit Switch			
003	Bit Switch 3		0	1
	bit 0 to 1	<b>DFU</b>	-	-
	bit 2	<b>[PCL5e/c]: Legacy HP compatibility</b>	0:Disabled	1:Enabled
	<p>Uses the same left margin as older HP models such as HP4000/HP8000. In other words, the left margin defined in the job (usually "&lt;ESC&gt;*r0A") will be changed to "&lt;ESC&gt;*r1A".</p>			
	bit 3 to 7	<b>DFU</b>	-	-

1001	Bit Switch			
004	Bit Switch 4		0	1
	bit 0 to 2	<b>DFU</b>	-	-
	bit 3	<b>Not used</b>	-	-
	bit 4 to 5	<b>DFU</b>	-	-
	bit 6	<b>Not used</b>	-	-
	bit 7	<b>DFU</b>	-	-

1001	Bit Switch			
005	Bit Switch 5		0	1
	bit 0	<b>Not used</b>	-	-
	bit 1	<b>Multiple copies if a paper size or type mismatch occurs</b>	0:Disabled (Single copy)	1:Enabled (Multiple copy)
		If a paper size or type mismatch occurs during the printing of multiple copies, only a single copy is output by default. Using this bit switch, the device can be configured to print all copies even if a paper mismatch occurs.		
	bit 2	<b>Prevent SDK applications from altering the contents of a job.</b>	0:Disabled	1:Enabled
		Enable: SDK applications will not be able to alter print data. This is achieved by preventing SDK applications from accessing a module called the "GPS Filter". <b>Note:</b> The main purpose of this bit switch is for troubleshooting the effects of SDK applications on data.		
	bit 3	<b>[PS] PS Criteria</b>	0: Pattern3	1: Pattern1

1001	Bit Switch			
		<p>Change the number of PS criterion used by the PS interpreter to determine whether a job is PS data or not.</p> <p>Pattern3: (2 to 4): The larger the pattern number, the greater the number of criterion used. Pattern 4 includes most PS commands.</p> <p>Pattern1: A small number of PS tags and headers</p>		
	bit 4	<p><b>Increase max. number of stored jobs.</b></p>	0:Disabled (100)	1:Enabled
		<p>Changes the maximum number of jobs that can be stored on the HDD. The default (disabled) is 100. If this is enabled, the max. will be raised to 750 or 1000 depending on the model.</p>		
	bit 5	<b>Not used</b>	-	-
	bit 6	<p><b>Method for determining the image rotation for the edge to bind on.</b></p>	0:Disabled	1:Enabled
		<p>Enable: The image rotation will be performed as they were in the specifications of older models for the binding of pages of mixed orientation jobs.</p> <p>The old models are below:</p> <ul style="list-style-type: none"> <li>- PCL: Pre-04A models</li> <li>- PS/PDF/RPCS: Pre-05S models</li> </ul>		
	bit 7	<p><b>Letterhead mode printing</b></p>	0:Disabled	1:Enabled (Duplex)
		<p>Routes all pages through the duplex unit.</p> <p>If this is disabled, simplex pages or the last page of an odd-paged duplex job are not routed through the duplex unit. This could result in problems with letterhead/pre-printed pages.</p> <p>Only affects pages specified as Letterhead paper.</p>		

1001	Bit Switch			
006	Bit Switch 6		0	1
	bit 0	<b>Not used</b>	-	-
	bit 1 to 5	<b>DFU</b>	-	-
	bit 6	<b>Not used</b>	-	-
	bit 7	<b>DFU</b>	-	-

1001	Bit Switch			
007	Bit Switch 7		0	1
	bit 0	<b>Not used</b>	-	-
	bit 1 to 7	<b>DFU</b>	-	-

1001	Bit Switch			
008	Bit Switch 8		0	1
	bit 0 to 2	<b>DFU</b>	-	-
	bit 3 to 4	<b>Not used</b>	-	-
	bit 5	<b>DFU</b>	-	-
	Bit 6 to 7	<b>Not used</b>	-	-

1001	Bit Switch			
009	Bit Switch 9		0	1
	bit 0	<b>PDL Auto Detection timeout of jobs submitted via USB or Parallel Port (IEEE 1284).</b>	0:Disabled (Immediately)	1:Enabled (10 seconds)
	To be used if PDL auto-detection fails. A failure of PDL autodetection does not necessarily mean that the job can not be printed. This bit switch tells the device whether to time-out immediately (default) upon failure or to wait 10 seconds.			
	bit 1	<b>Not used</b>	-	-
	bit 2	<b>Job Cancel</b>	0:Disabled (Not cancelled)	1:Enabled (Cancelled)
Enable: All jobs will be cancelled after a jam occurs. <b>Note:</b> If this bit switch is enabled, printing under the following conditions might result in problems: - Job submission via USB or parallel port - Spool printing (WIM > Configuration > Device Settings > System)				
	bit 3	<b>Not used</b>	-	-
	bit 4	<b>Timing of the PjL Status ReadBack (JOB END) when printing multiple collated copies.</b>	0:Disabled	1:Enabled
This bit switch determines the timing of the PjL USTATUS JOB END sent when multiple collated copies are being printed. Disable (=0 (default)): JOB END is sent by the device to the client after the first copy has completed printing. This causes the page counter to be incremented after the first copy and then again at the end of the job. Enable (=1): JOB END is sent by the device to the client after the last copy has finished printing. This causes the page counter to be incremented at the end of each job.				

1001	Bit Switch		
009	Bit Switch 9	0	1
	bit 5	<b>Display UTF-8 text in the operation panel</b>	0:Enabled 1:Disabled
		<p>Enable (=0): Text composed of UTF-8 characters can be displayed in the operation panel.</p> <p>Disable (=1): UTF-8 characters cannot be displayed in the operation panel. For example, job names are sometimes stored in the MIB using UTF-8 encoded characters. When these are displayed on the operation panel, they will be garbled unless this bit switch is enabled (=0).</p>	
	bit 6	<b>Disable super option</b>	0:Enabled 1:Disabled
		<p>Switches super option disable on / off. If this is On, multiple jobs are grouped at LPR port. P.JL settings are enabled even jobs that are specified queue names are sent.</p>	
	bit 7	<b>Enable/Disable Print from USB/SD's Preview function</b>	0:Enabled 1:Disabled
		<p>Determines whether print from USB/SD will have the Preview function. Enabled (=0): Print from USB/SD will have the Preview function. Disabled (=1): Print from USB/SD will not have the Preview function.</p>	

1001	Bit Switch		
010	Bit Switch A	0	1
	bit 0 to 3	<b>DFU</b>	- -
	bit 4	<b>Not Used</b>	- -
	bit 5	<b>Store and Skip Errored Job locks the queue</b>	0: Queue is not locked after SSEJ 1: Queue locked after SSEJ

1001		Bit Switch		
		If this is 1, then after a job is stored using Store and Skip Errored Job (SSEJ), new jobs cannot be added to the queue until the stored job has been completely printed.		
	bit 6	<b>Allow use of Store and Skip Errored Job if connected to an external charge device.</b>	0: Does not allow SSEJ with ECD	1: Allows SSEJ with ECD
		If this is 0, Store and Skip Errored Job (SSEJ) will be automatically disabled if an external charge device is connected. <b>Note:</b> We do not officially support enabling this bit switch (1). Use it at your own risk.		
		<b>Job cancels remaining pages when the paid-for pages have been printed on an external charge device</b>	Job does not cancel	Job cancels
	bit 7	When setting 1 is enabled, after printing the paid-for pages on an external charge device, the job that includes any remaining pages will be canceled. This setting will prevent the next user from printing the unnecessary pages from the previous user's print job.		

1001		Bit Switch		
011	Bit Switch B		0	1
	bit 0	<b>Show Menu List</b>	Hide Menu List	Show Menu List
		If this is 0, the Menu List button will be removed from Printer Features.		
		<b>Print job interruption</b>	Does not allow interruption	Allow interruption
	bit 1	0 (default): Print jobs are not interrupted. If a job is promoted to the top of the print queue, it will wait for the currently printing job to finish. 1: If a job is promoted to the top of the queue, it will interrupt the currently printing job and start printing immediately.		



1001		Bit Switch		
		<b>Switch for enabling or disabling Limitless Paper Feeding for the Bypass Tray</b>	0: Enable	1: Disable
	bit 2	<p>When the Bypass Tray is the target of the Auto Tray Select and Any Size/Type is configured for the Tray Setting Priority setting of the Bypass Tray, this BitSwitch can switch the behavior whether or not Limitless Paper Feeding is applied to the Bypass Tray.* The default is Enabled (=0).                      *Limitless Paper Feeding will try a matching tray of the next highest priority if a job specified to Auto Tray Select as the tray setting is submitted and the tray runs out of paper.</p> <p>Enabled (=0: Default):                      Limitless Paper Feeding is applied to the Bypass Tray.                      If a tray other than the Bypass Tray matches the job's paper size and type but has run out of paper, printing will occur from the Bypass Tray.</p> <p>Disabled (=1):                      Limitless Paper Feeding is not applied to the Bypass Tray.                      If a tray other than the Bypass Tray matches the job's paper size and type but has run out of paper, printing will stop and an alert will appear on the LCD screen, stating that the tray has run out of paper. This prevents unexpected use of the Bypass Tray.</p> <p>Limitations when this BitSwitch is set to "1":                      - The "Paper Tray Priority: Printer" setting must be configured to a tray other than the Bypass Tray.                      - Jobs that contain more than one paper size cannot be printed.</p>		
	bit 3	<b>DFU</b>	-	-
	bit 4	<b>Add "Apply Auto Paper Select" is the condition that decides if the device's paper size or paper type should be overwritten.</b>	0:Enabled	1:Disabled

1001		Bit Switch		
		<p>If this BitSwitch is set to "1" (enabled), the "Apply Auto Paper Select" setting will decide if the paper size or paper type that is specified in the device settings should be overwritten by the job's commands when "Tray Setting Priority" is set to "Driver/Command" or "Any Type".</p> <ul style="list-style-type: none"> <li>- Apply Auto Paper Select = OFF: Overwritten (priority is given to the job's commands)</li> <li>- Apply Auto Paper Select = ON: Not overwritten (priority is given to the device settings)</li> </ul>		
	bit 5 to 7	<b>Not Used</b>	-	-

1001		Bit Switch		
012	Bit Switch C		0	1
	bit 0	<b>DFU</b>	-	-
	bit 1 to 4	<b>Not Used</b>	-	-
		<b>Change the user ID type displayed on the operation panel</b>	0:Enabled	1:Disabled
	bit 5	<p>As of 15S models, the Login User Name can be displayed on the operation panel. The user ID type displayed on the operation panel can be changed by configuring BitSwitch #12-5 as follows:</p> <ul style="list-style-type: none"> <li>- 0 (default): Login User Name</li> <li>- 1: User ID. If this is enabled, User ID will be displayed, which is equivalent to the behavior exhibited in 14A and earlier models.</li> </ul>		
		<b>Ability to use AirPrint</b>	Enabled	Disabled
	bit 6	<p>For 15S and later models that support AirPrint, AirPrint can be disabled by changing this Bit Switch from 0 (default) to 1.</p>		
	bit 7	<b>Not Used</b>		

<b>1003</b>	<b>[Clear Setting]</b>	
1003-001	Initialize System	Initializes settings in the System menu of the user mode.
1003-003	Delete Program	DFU

<b>1004</b>	<b>[Print Summary]</b>	
1004-001	Service Summary	Prints the service summary sheet (a summary of all the controller settings).

<b>1005</b>	<b>[Display Version]</b>	
1005-002	Printer Version	Displays the version of the controller firmware.

<b>1006</b>	<b>[Sample/Locked Print]</b>	
1006-001	0:Link with Doc. Srv 1:Enable	-

<b>1101</b>	<b>[ToneCtlSet]</b>	
1101-001	Tone (Factory)	-
	Recalls a set of gamma settings. This can be either a) the factory setting, b) the previous setting, or c) the current setting.	

<b>1102</b>	<b>[Resolution Settings]</b>	
	<p>Sets the printing mode (resolution) for the printer gamma adjustment. The asterisk (*) shows which mode is set.</p> <ul style="list-style-type: none"> <li>▪ 00: *1200x1200Photo</li> <li>▪ 01: 600x600Text</li> <li>▪ 02: 1200x1200Text</li> <li>▪ 03: 1200x600Text</li> <li>▪ 04: 600x600Photo</li> <li>▪ 05: 1200x600Photo</li> <li>▪ 06: 600x600Text</li> <li>▪ 07: 600x600Text</li> </ul>	
1102-001	Tone Control Mode Selection	[0 to 99 / <b>0</b> / 1/step]

<b>1103</b>	<b>[PrnColorSheet]</b>	
1103-001	ToneCtlSheet	Prints the test page to check the color balance before and after the gamma adjustment.
1103-002	ColorChart	

<b>1104</b>	<b>[ToneCtlValue]</b>	
	Adjusts the printer gamma for the mode selected in the Mode Selection menu.	
1104-001	Black: Highlight	[0 to 30 / <b>0</b> / 1/step]
1104-021	Cyan: Highlight	
1104-041	Magenta: Highlight	
1104-061	Yellow: Highlight	
1104-002	Black: Shadow	[0 to 30 / <b>0</b> / 1/step]
1104-022	Cyan: Shadow	
1104-042	Magenta: Shadow	
1104-062	Yellow: Shadow	
1104-003	Black: Middle	[0 to 30 / <b>0</b> / 1/step]

1104-023	Cyan: Middle		
1104-043	Magenta: Middle		
1104-063	Yellow: Middle		
1104-004	Black: IDmax		[0 to 30 / 0 / 1/step]
1104-024	Cyan: IDmax		
1104-044	Magenta: IDmax		
1104-064	Yellow: IDmax		

<b>1105</b>	<b>[Save Tone Control Value]</b>	
	Saves the print gamma (adjusted with the Gamma Adj.) as the new Current Setting. Before the machine stores the new "current settingR", it moves the data stored as the "current setting" to the "previous setting" memory-storage location.	
1105-001	Save Tone Control Value	[EXECUTE]

<b>1106</b>	<b>[Toner Limit]</b>	
	Adjusts the maximum toner amount for image development.	
1106-001	Toner Limit Value	[100 to 400 / 0 / 1/step]

<b>1110</b>	<b>[Media Print Device Setting]</b>	
	Enable or disable the media print support function. 0: Disable, 1:Enable	
1110-002	0: Disable 1:Enable	[0 to 1 / 1 / 1/step]

Printer Service Mode

1111	<b>[All Job Delete Mode]</b>	
	- 0: Exclusive New Job, 1:Including New Job	
1110-002	0: Exclusive New Job 1: Including New Job	[0 or 1 / 1 / 1/step]

## 3.13 SCANNER SERVICE MODE

### 3.13.1 SP1-XXX

<b>1001</b>	<b>[Scan Nv Version]</b>		
1-001-005	-	CTL*	[- / - / - / step]

<b>1005</b>	<b>[Erase margin(Remote scan)]</b>		
1-005-001	Range from 0 to 5 mm	CTL*	[0 to 5 / <b>0</b> / 1 / step]

<b>1009</b>	<b>[Remote scan disable]</b>		
1-009-001	0:enable 1:desable	CTL*	[0 or 1 / <b>0</b> / 1 / step]

<b>1010</b>	<b>[Non Display ClearLight PDF]</b>		
1-010-001	0:Display 1:Nondisplay	CTL*	[0 or 1 / <b>0</b> / 1 / step]

<b>1011</b>	<b>[Org Count Disp]</b>		
1-011-001	0:ON 1:OFF	CTL*	[0 or 1 / <b>0</b> / 1 / step]

<b>1012</b>	<b>[UserInfo Release]</b>		
1-012-001	0:No 1:Yes	CTL*	[0 or 1 / <b>1</b> / 1 / step]

<b>1013</b>	<b>[Scan to Media Device Setting]</b>		
1-013-002	0:OFF 1:ON	CTL*	[0 or 1 / <b>1</b> / 1 / step]

<b>1014</b>	<b>[Scan to Folder Pass Input Set]</b>		
1-014-001	0:OFF 1:ON	CTL*	[0 or 1 / <b>0</b> / 1 / step]

<b>1041</b>	<b>[Scan:FlairAPI Setting]</b>		
1-041-001	0x00 - 0xff	CTL*	[0 to 255 / <b>0</b> / 1 / step]

### 3.13.2 SP2-XXX

<b>2021</b>	<b>[Compression Level(Grayscale)]</b>		
2-021-001	Comp1:5-95	CTL*	[5 to 95 / <b>20</b> / 1 / step]
2-021-002	Comp2:5-95	CTL*	[5 to 95 / <b>40</b> / 1 / step]
2-021-003	Comp3:5-95	CTL*	[5 to 95 / <b>65</b> / 1 / step]
2-021-004	Comp4:5-95	CTL*	[5 to 95 / <b>80</b> / 1 / step]
2-021-005	Comp5:5-95	CTL*	[5 to 95 / <b>95</b> / 1 / step]

<b>2024</b>	<b>[Compression ratio of ClearLightPDF]</b>		
2-024-001	Compression Ratio(Normal)	CTL*	[5 to 95 / <b>25</b> / 1 / step]
2-024-002	Compression Ratio(High)	CTL*	[5 to 95 / <b>20</b> / 1 / step]

<b>2025</b>	<b>[Compression ratio of ClearLightPDF JPEG2000]</b>		
2-025-001	Compression Ratio(Normal) JPEG2000	CTL*	[5 to 95 / <b>25</b> / 1 / step]
2-025-002	Compression Ratio(High) JPEG2000	CTL*	[5 to 95 / <b>20</b> / 1 / step]



2030	[OCR PDF DetectSens]		
2-030-001	White Lumi Value: 0 - 255	CTL*	[0 to 255 / <b>250</b> / 1 / - / step]
2-030-002	White Pix Ratio: 0 - 100	CTL*	[0 to 100 / <b>80</b> / 1 / - / step]
2-030-003	White Tile Ratio: 0 -100	CTL*	[0 to 100 / <b>80</b> / 1 / - / step]

## 3.14 INPUT AND OUTPUT CHECK

### 3.14.1 INPUT CHECK TABLE (SP5-803)

When entering the Input Check mode, 8 digits display the result for a section. Each digit corresponds to a different device as shown in the table.

Bit No.	7	6	5	4	3	2	1	0
Result	0 or 1	0 or 1	0 or 1	0 or 1	0 or 1	0 or 1	0 or 1	0 or 1

SP	Description	Reading	
		0	1
5-803-001	Tray: Paper Set Sensor	Paper detected	Paper not detected
5-803-002	Bypass: Paper Set Sensor	Paper detected	Paper not detected
5-803-003	RVS: Paper Exit Sensor	Paper detected	Paper not detected
5-803-004	Registration Sensor	Paper detected	Paper not detected
5-803-005	Duplex: Exit Sensor	Paper detected	Paper not detected
5-803-006	Duplex Entrance Sensor	Paper detected	Paper not detected
5-803-011	Front Interlock SW	Open	Close
5-803-012	Right Interlock SW	Open	Close
5-803-013	Exhaust Fan: Lock	Lock	Normal
5-803-014	Intake Fan: Lock	Lock	Normal
5-803-015	Main Motor Lock	Lock	Normal
5-803-016	Key Card Set	Set	Not set
5-803-017	Key Counter Set		
5-803-018	BICU Version		
5-803-019	Right Door Open/Close Switch	Close	Open
5-803-020	Paper Exit Sensor	Paper detected	Paper not detected

SP	Description	Reading	
		0	1
5-803-200	Scanner HP Sensor		
5-803-201	Platen Cover Sensor		
5-803-211	Bank1: Feed Cover Open Detection		
5-803-212	Bank1:Paper End Sensor		
5-803-213	Bank1:Feed Sensor		
5-803-214	Bank1:Upper Limit Sensor		
5-803-215	Bank1:Tray Set Sensor		

### 3.14.2 OUTPUT CHECK TABLE (SP5-804)

Activates the electrical components for functional check.

It is not possible to activate more than one component at the same time.

SP	Display
5-804-001	Main Motor: CW: Standard Spd
5-804-002	Main Motor: CW: Low Spd
5-804-005	Toner Bottle Motor: CCW
5-804-008	Intake Fan Motor: Full Spd
5-804-009	Intake Fan Motor: Half Spd
5-804-010	HVP: Transfer: -
5-804-011	HVP: Transfer: +
5-804-012	HVP.: Separation Voltage
5-804-013	HVP.: Development
5-804-014	HVP.: Charge
5-804-015	Potential Sensor

Input and Output Check

SP	Display
5-804-016	Fusing Solenoid
5-804-017	Drum Quenching LED
5-804-018	Paper Feed CL
5-804-019	Registration CL
5-804-020	Bypass CL
5-804-021	Duplex: RVS Sensor CL
5-804-022	Paper Exit RVS CL
5-804-023	Paper Exit CL
5-804-024	Anti-Condensation Heater
5-804-027	Exhaust Fan Motor
5-804-028	Pre Cleaning Lamp
5-804-049	Polygon Motor: High Spd
5-804-050	Polygon Motor: Low Spd
5-804-202	Scanner Lamp: Color
5-804-203	Scanner Lamp: Bk
5-804-241	Bank1:Feed Motor
5-804-242	Bank1:Paper feed clutch

**APPENDIX:**

**DEVICE SOFTWARE CONFIGURATION**

<b>REVISION HISTORY</b>		
<b>Page</b>	<b>Date</b>	<b>Added/Updated/New</b>
		None



---

## 4. DEVICE SOFTWARE CONFIGURATION

### 4.1 PRINTING FEATURES

#### 4.1.1 BEHAVIOR OF USB PRINTER DETECTION

An MFP/LP connected via USB sends its product name and unique serial number. With the data, the machine determines whether requires a printer driver for the USB device to be installed.

SP5-844-005 allows you to change how to determine the MFP/LP requires a printer driver installation:

- **OFF**  
If SP5-844-005 is set to OFF, the unique serial number of the device is sent to the computer. As a result, if the device is swapped out for a device of the same product, pop-up messages will appear, because the serial numbers between the two are different.
- **Level 1**  
If SP5-844-005 is set to Level 1, a common serial number for the product such as “RICOH MP 305+” series is sent to the computer. As a result, if the device is swapped out for a device of the same product, pop-up messages will not appear because the devices are recognized as having the same serial number.
- **Level 2**  
If SP5-844-005 is set to Level 2, a common serial number for all GW/GW+ models is sent to the computer. As a result, if a GW/GW+ device is swapped out for a different GW/GW+ device, pop-up messages will not appear because the devices are both recognized as being based on GW/GW+.

### 4.2 SCANNING FEATURES

None

## 4.3 MANAGEMENT FEATURES

### 4.3.1 HOW TO DISABLE THE DOCUMENT SERVER FUNCTION

1. Enter 'Copy' SP mode.
2. Change SP5-967-001 to 1. (0:ON 1:OFF)
3. Reboot the machine.

 **Note**

- When the above SP mode (SP5-967-001) is OFF (=1), both the Document Server and Locked Print functions will be disabled.

#### How to Use Locked Print When the Document Server Is Disabled

1. Enter 'Printer' SP mode.
2. Set SP1-006-001 to 1.  
0: Link with Doc. Srv (default)  
Locked print will only be enabled if the document server is enabled.  
1: Enable  
Enable Locked  
Print will be enabled no matter the status of the document server.
3. Turn OFF then ON the main power.



## 4.4 SECURITY FEATURES

### 4.4.1 HOW TO RESTRICT ACCESS TO THE WIM JOB MENU

1. Enter 'Printer' SP mode.
2. Set SP5-888-001
  - 0: (default): "Job" menu is enabled.
  - 1: "Job" menu is disabled.

#### ↓ Note

- This setting takes effect only if user authentication (other than User Code auth.) is disabled.



### 4.4.2 HOW TO RESTRICT WEB IMAGE MONITOR ACCESS TO THE DOCUMENT SERVER

System (Copier) SP 5-885-020 bit 0, 1 and 7 restrict Web Image Monitor access to the DS. It disables the following WIM settings:

- The entire Document Server menu (shown in blue in fig1)
- Job > Document Server (shown in red in fig1)

See the following for details:

#### Bit 0:

Bit 0 = 0 (default): Allows anyone (guests, users, admins) access to the DS via WIM.

Bit 0 = 1: Prevents everyone from accessing the DS via WIM.

#### Bit 1:

Bit 1 = 0 (default): Allows anyone (guests, users, admins) access to the DS via WIM.

Bit 1 = 1: Only administrators can access the DS via WIM.

#### ↓ Note

- Without admin privileges, even authenticated users will be unable to access the DS via WIM.

## Security Features

### Bit 7:

Bit 7 = 0 (default): Allows anyone (guests, users, admins) access to the DS via WIM.

Bit 7 = 1: Only administrators and authenticated users can access the DS via WIM.

The most restrictive result of combining these three configurations will take priority. So for example:

Bit 0 = 0

Bit 1 = 1

Bit 7 = 1

As Bit 1 = 1 is the most restrictive of the three, it will take precedence over the other two and only administrators will be able to access the DS via WIM.



### Note

- In order for SP5-885-020 to have any effect, the Document Server must be enabled (SP5-967-001=0). For information about SP5-967-001, refer to Disabling the Document Server using System SP5-967-001 and Printer SP1-006-001.
- Access to the entire "Job" menu can be restricted using SP 5-888-001. For details, refer to Use of SP 5-888-001 to restrict access to the "Job" menu on WIM.

### 4.4.3 USER AUTHENTICATION FOR SPECIFIC MFP APPLICATIONS

The SP5-420 settings enable/disable User Authentication for specific MFP applications.

SP 5-420	User Authentication	Value (Default: 0)	
SP5-420-001	Copy	0 (ON)	1 (OFF)
SP5-420-011	Document Server		
SP5-420-021	Fax		
SP5-420-031	Scanner		
SP5-420-041	Printer		

**1. Enable User Authentication for the device as a whole:**

User Tools > System Settings > Administrator Tools > User Authentication Management

**2. Use the SP5-420 settings to specify the applications to which User authentication is to apply.**

## 4.5 CONNECTIVITY

None

# SMART OPERATION PANEL

## 2nd GENERATION

REVISION HISTORY		
Page	Date	Added/Updated/New
		None



# SMART OPERATION PANEL

## 2nd GENERATION

### TABLE OF CONTENTS

<b>1. REPLACEMENT AND ADJUSTMENT .....</b>	<b>1</b>
1.1 SMART OPERATION PANEL .....	1
1.1.1 OPERATION PANEL UNIT .....	1
1.1.2 CPU BOARD .....	3
1.1.3 MICRO COMPUTER BOARD .....	6
1.1.4 WI-FI MODULE .....	8
1.1.5 LCD .....	9
1.1.6 SPEAKER .....	11
1.1.7 MICROPHONE .....	12
<b>2. MECHANISM .....</b>	<b>14</b>
2.1 OVERVIEW .....	14
2.1.1 SYSTEM COMPONENTS .....	14
Hardware Specifications .....	14
Software Specifications .....	18
Communication specifications .....	20
Application Specifications .....	22
2.1.2 PANEL COMPONENTS/SCREEN LAYOUT .....	26
Components of the Control Panel .....	26
Panel display .....	28
2.1.3 ELECTRICAL COMPONENTS .....	30
Touch panel .....	30
2.2 CONTROLLING THE POWER SUPPLY .....	32
2.2.1 EXITING ENERGY SAVING MODES .....	32
2.2.2 SCREEN STARTUP MODE .....	34
Startup Modes .....	34
Changing the Screen Startup Mode .....	34
How the Control Panel Starts Up .....	35
How the Screen Shuts Down When Quick mode Is Selected .....	35
2.2.3 SHUTDOWN FUNCTIONS .....	36
Normal Shutdown .....	36
Other Shutdown Functions .....	36

<b>3. SYSTEM MAINTENANCE.....</b>	<b>37</b>
3.1 SYSTEM MAINTENANCE .....	37
3.1.1 MAINTENANCE MODES .....	37
3.1.2 LOGIN TO/LOGOUT FROM CONTROL PANEL SERVICE MODE .....	38
Login .....	38
Login Status Indicator.....	38
Logout.....	39
When Entry to Service Mode Is Prohibited by the Administrator .....	39
3.1.3 SERVICE MODE MENU .....	40
WIRELESS & NETWORKS .....	40
DEVICE .....	41
SYSTEM.....	43
3.1.4 PANEL SELF CHECK .....	45
LED Check .....	46
Key Check .....	46
LCD Check .....	47
Speaker Check .....	48
TouchPanel Check .....	49
TouchPanel Calibration .....	50
MultiTouch Calibration.....	51
Wireless LAN Check .....	52
Bluetooth Check .....	53
3.1.5 RECOVERY MODE.....	54
3.2 SOFTWARE UPDATE .....	55
3.2.1 UPDATING THE SMART OPERATION PANEL.....	55
3.2.2 INSTALLATION/UPDATE FROM AN SD CARD.....	56
Updating the Smart Operation Panel Firmware.....	56
Installing/Updating an Application .....	59
3.2.3 PACKAGE UPDATE .....	59
When Installation/Update Is Prohibited.....	59
3.2.4 INSTALLATION/UPDATE FROM THE EDC SERVER .....	60
Check Server Connect.....	60
Installation .....	61
Activation.....	61
Update.....	62
<b>4. TROUBLESHOOTING .....</b>	<b>63</b>
4.1 TROUBLESHOOTING.....	63
4.1.1 SOFTWARE UPDATE ERRORS .....	63
Errors that occur during application update from an SD card.....	63

Errors that occur during update from the eDC Server .....	65
Errors that occur during remote (batch file) update .....	66
4.1.2 ERRORS THAT OCCUR WHEN THE CONTROL PANEL DOWNLOADS DATA FROM THE CONTROLLER AT STARTUP.....	72









# READ THIS FIRST

## Symbols, Abbreviations and Trademarks

This manual uses several symbols and abbreviations. The meaning of those symbols and abbreviations are as follows:

	Clip ring
	Screw
	Connector
	Clamp
SEF	Short Edge Feed
LEF	Long Edge Feed

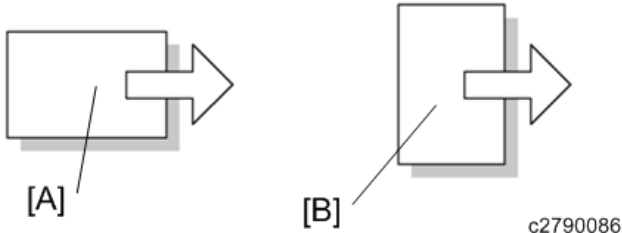

[A] Short Edge Feed (SEF)

[B] Long Edge Feed (LEF)

## Trademarks

Microsoft<sup>®</sup>, Windows<sup>®</sup>, and MS-DOS<sup>®</sup> are registered trademarks of Microsoft Corporation in the United States and /or other countries.

PostScript<sup>®</sup> is a registered trademark of Adobe Systems, Incorporated.

PCL<sup>®</sup> is a registered trademark of Hewlett-Packard Company.

Ethernet<sup>®</sup> is a registered trademark of Xerox Corporation.

PowerPC<sup>®</sup> is a registered trademark of International Business Machines Corporation.

Android is a trademark of Google Inc.

Other product names used herein are for identification purposes only and may be trademarks of their respective companies. We disclaim any and all rights involved with those marks.



# 1. REPLACEMENT AND ADJUSTMENT

## 1.1 SMART OPERATION PANEL

### 1.1.1 OPERATION PANEL UNIT

#### ★ Important

- Turn off the main power switch of the MFP and disconnect the power cord.
- After replacing, make sure that all disconnected harnesses are connected up again and secured in their clamps (if the MFP has harnesses).

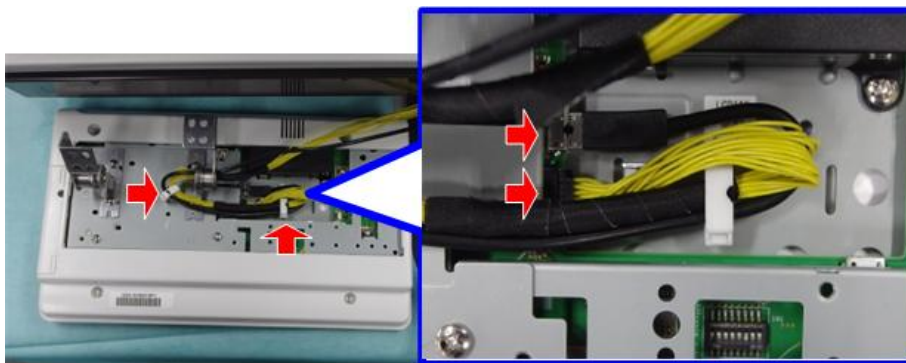

d196z4105

#### 1. Remove the operation panel unit from the MFP.

##### ↓ Note

- For details about how to remove the operation panel unit, refer to the service manual for the MFP.

#### 2. Operation panel arm bracket [A] (⌀ x4)



d196z0113

##### ↓ Note

- By factory default, switches No.3 and No.7 of the DIP switch [A] on the micro computer board are set to ON. When installing the operation panel unit, make sure that the DIP switch setting is correct for the MFP on which you are installing the panel.

## Smart Operation Panel

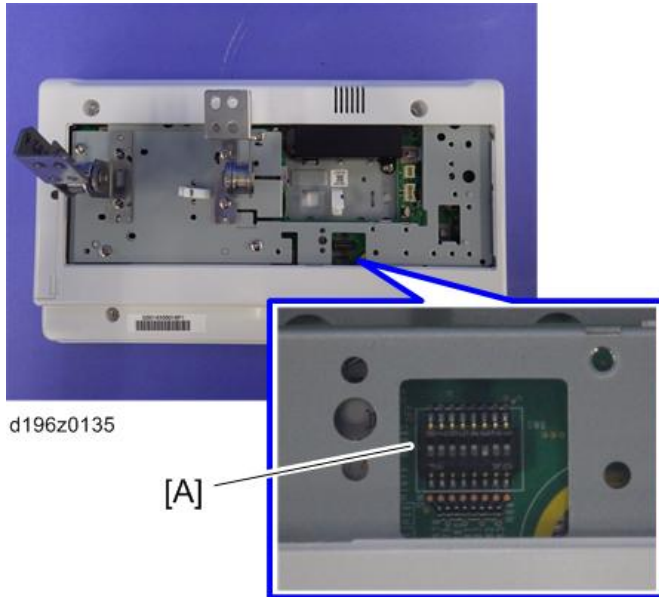

- The correct DIP switch setting depends on the MFP. Note the DIP switch settings of the old operation panel unit before replacing, and apply the same settings to the new Smart Operation Panel. (Below are two examples for DIP switch settings.)

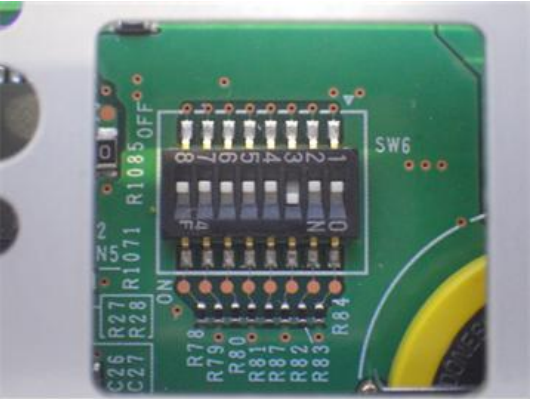
<p>When No.3 and No.7 are set to ON</p> <ul style="list-style-type: none"> <li>▪ This is the factory default setting of a service part</li> </ul>	<p>When only No.3 is set to ON</p>
 <p>d196z0136</p>	 <p>d196z0137</p>

- If the DIP switch setting is wrong, SC672 will be displayed.
- After replacing the operation panel unit, make sure that the latest version of the firmware is installed on the Smart Operation Panel. Update it if necessary (page 55 "Updating the Smart Operation Panel").

## 1.1.2 CPU BOARD

1. Operation panel unit (page 1)
2. Bottom cover [A] (🔑 x4)

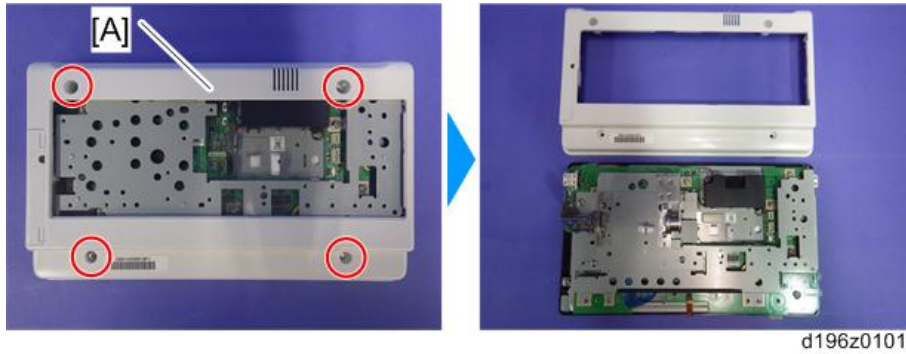

### ⚠ Note

- There are four hooks inside the operation panel unit. Before removing the operation panel bottom cover, check the photos below.

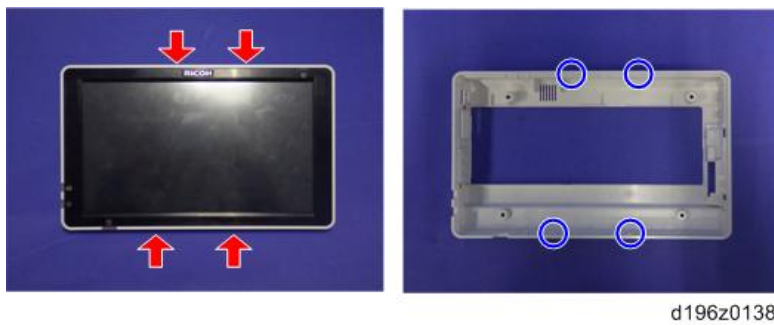

3. Base bracket [A] (🔑 x9)

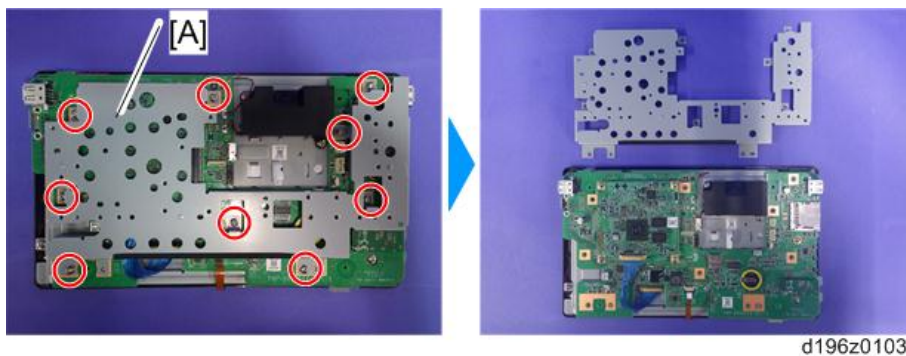

4. Remove the fixing screws (🔑 x4) on the CPU board [A], and remove the CPU board from the micro computer board.

## Smart Operation Panel

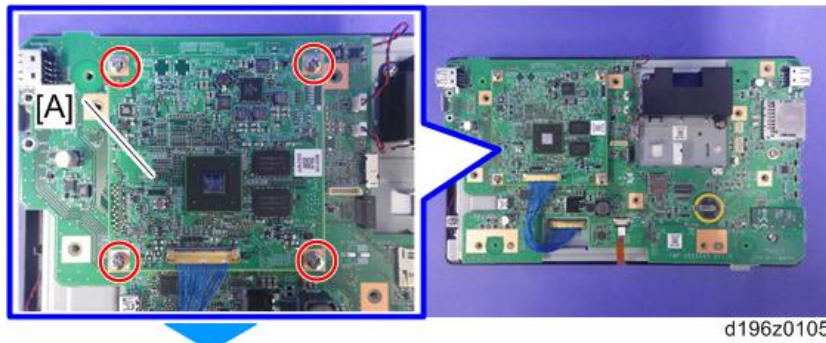

### ↓ Note

- Make sure that the orientation of the connector is correct when attaching the CPU board.



5. Lift the fastener of the LCD I/F cable on the CPU board side.

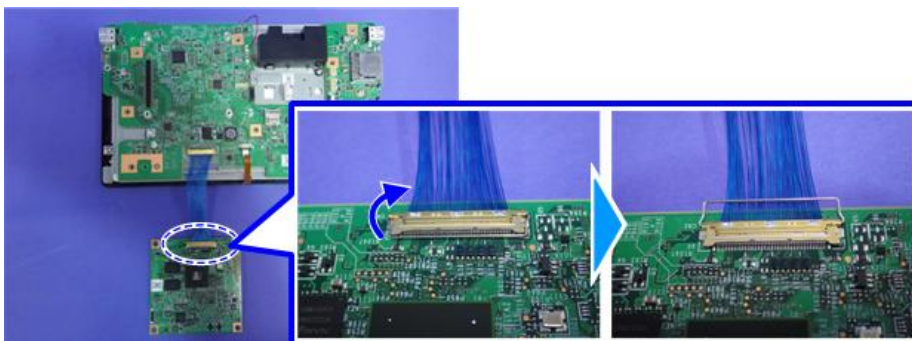

6. CPU board [A] (LCD I/F cable x1)



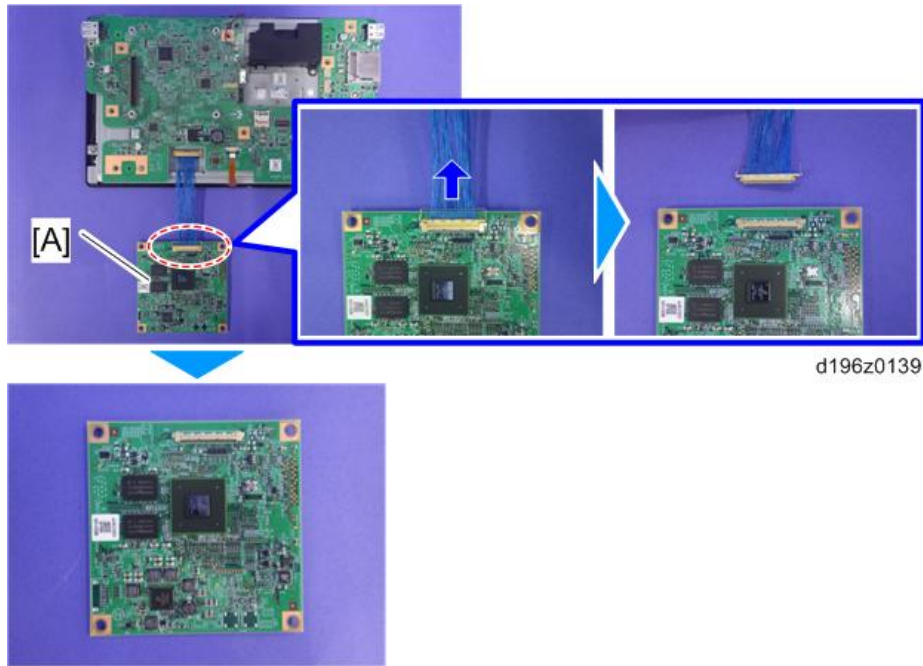

↓ Note

- After replacing the CPU board, make sure that the latest version of the firmware is installed on the Smart Operation Panel. Update it if necessary. (page 55 "Updating the Smart Operation Panel")



### 1.1.3 MICRO COMPUTER BOARD

1. Operation panel unit (page 1)
2. CPU board (page 3)
3. Remove the FFC from the micro computer board (  x1).

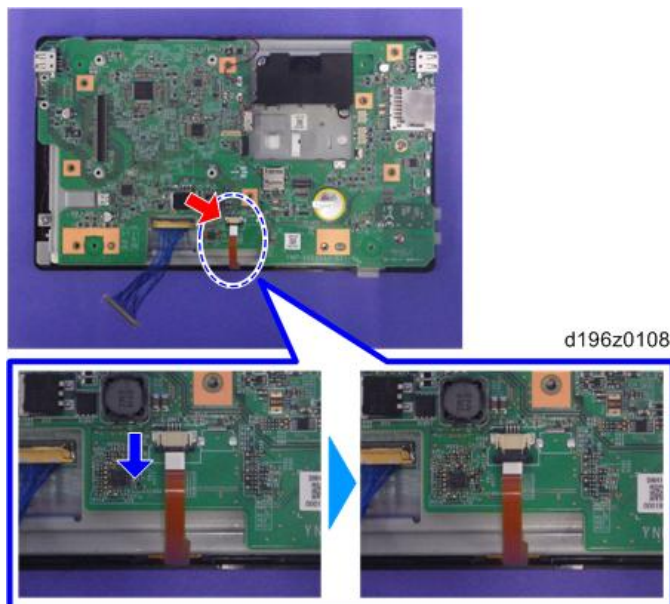

 Note

- Pull out the black part to unlock the connector, and then remove the FFC.

4. Micro computer board [A] (  x1,  x2)

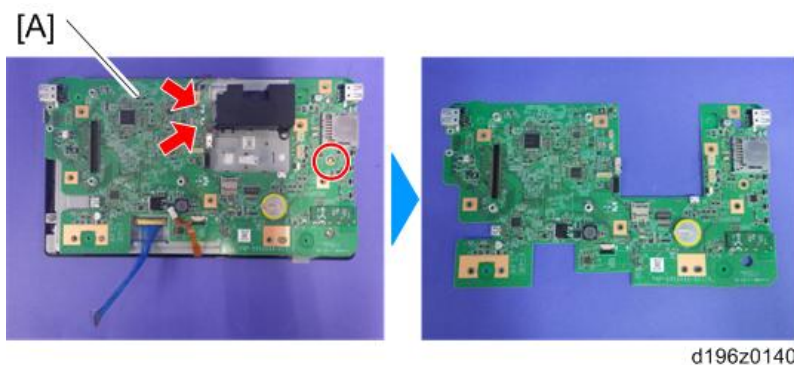

 Note

- By factory default, switches No.3 and No.7 of the DIP switch [A] on the micro computer board are set to ON. When installing the operation panel unit, make sure that the DIP switch setting is correct for the MFP on which you are installing the panel.

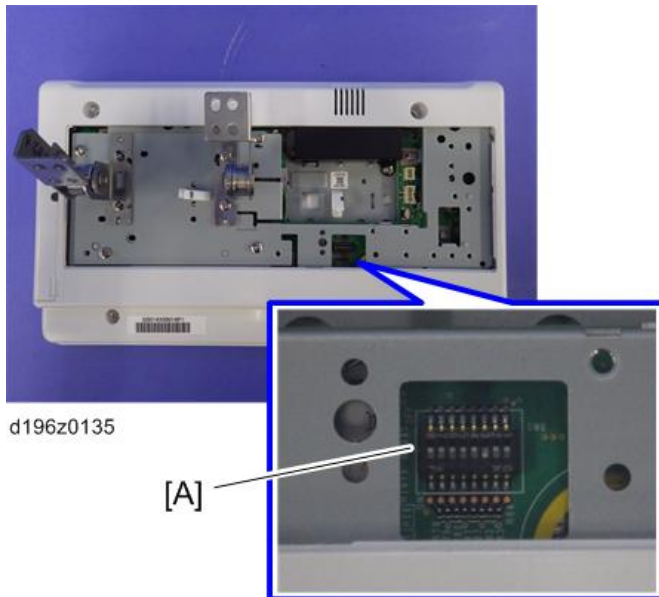

- The correct DIP switch setting depends on the MFP. Note the DIP switch settings of the old operation panel unit before replacing, and apply the same settings to the new Smart Operation Panel. (Below are two examples for DIP switch settings.)

<p>When No.3 and No.7 are set to ON</p> <ul style="list-style-type: none"> <li>▪ This is the factory default setting of a service part</li> </ul>	<p>When only No.3 is set to ON</p>
<p>d196z0136</p>	<p>d196z0137</p>

- If the DIP switch setting is wrong, SC672 will be displayed.
- After replacing the micro computer board, perform the following checks:
  - LED Check (page 46)
  - Key Check (page 46)

### 1.1.4 WI-FI MODULE

1. Operation panel unit (page 1)
2. Bottom cover [A] (⚙️ x4)

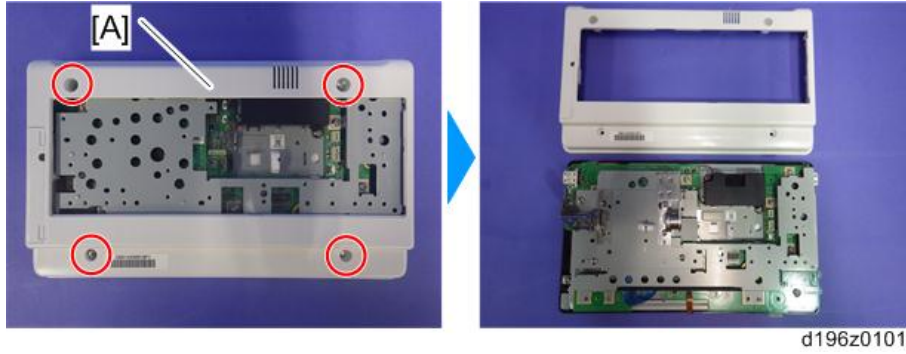

3. Base bracket [A] (⚙️ x9)

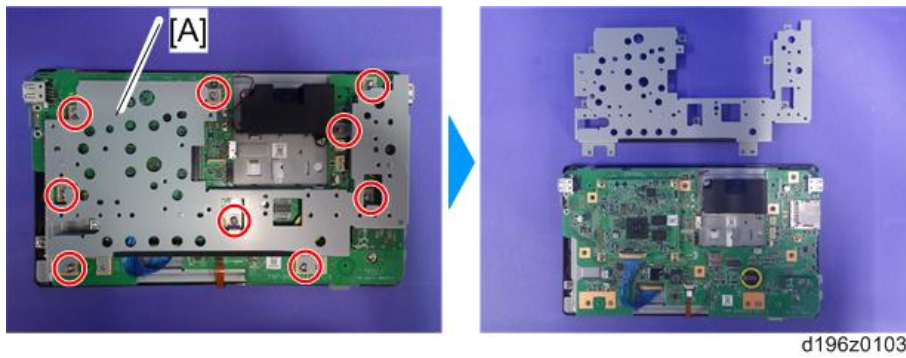

4. Wi-Fi module [A] (⚙️ x1)

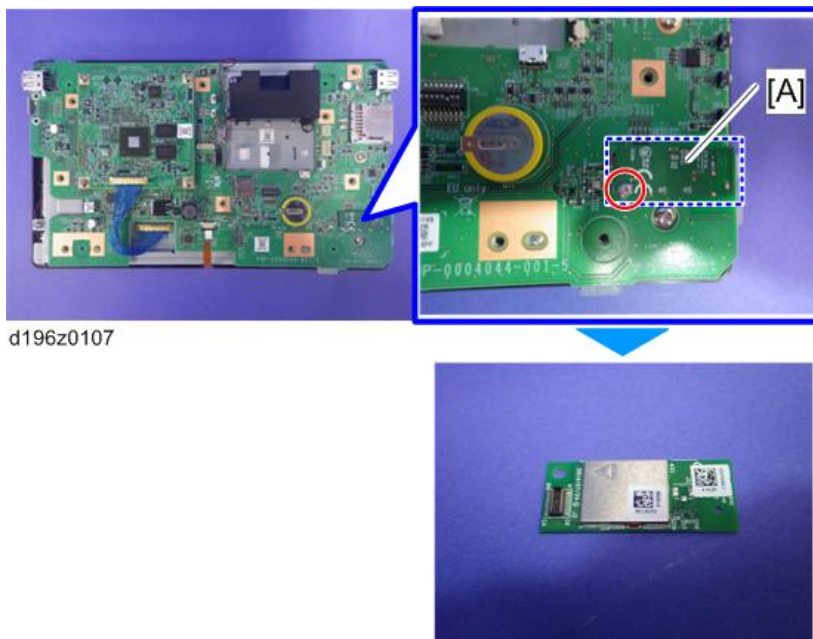

**Note**

- After replacing the Wi-Fi module, perform the following checks:
  - Wireless LAN Check (page 52)
  - Bluetooth Check (page 53)

### 1.1.5 LCD

1. Operation panel unit (page 1)
2. CPU board (page 3)
3. Micro computer board (page 6)
4. Speaker [A] (🔊 x2)

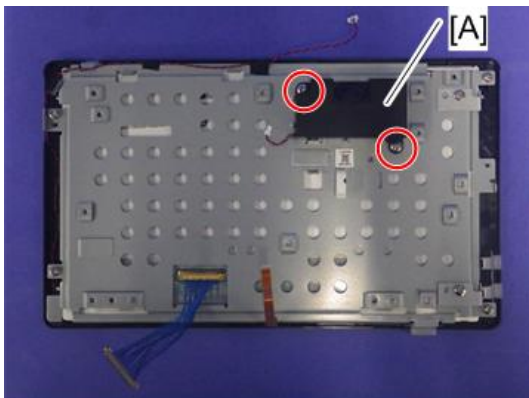

d196z0109

5. Lift the fastener of the LCD I/F cable.

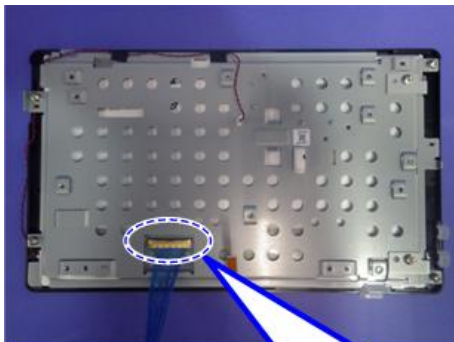

d196z0116

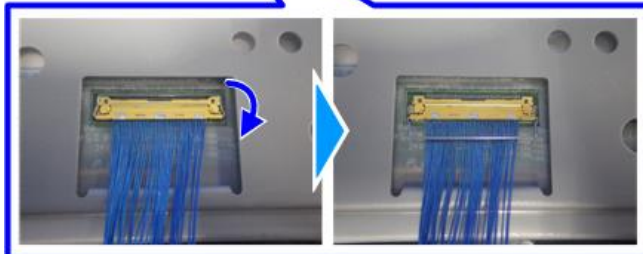

6. LCD I/F cable (cable x1)



## Smart Operation Panel

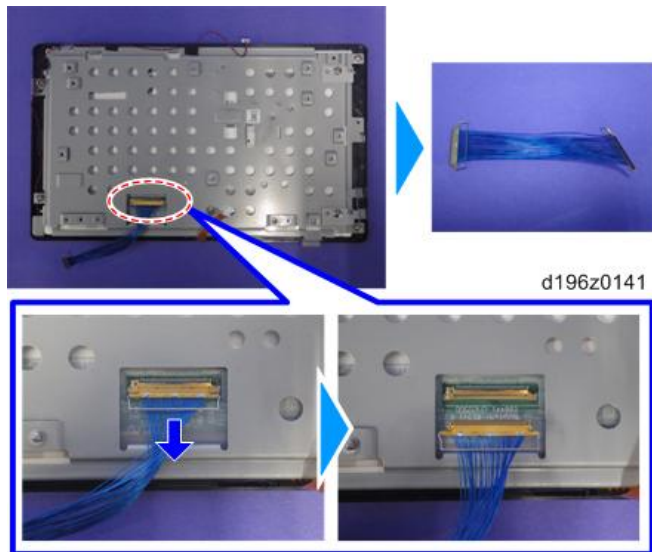

### 7. Remove the tapes for fixing the microphone harness (tape x3).

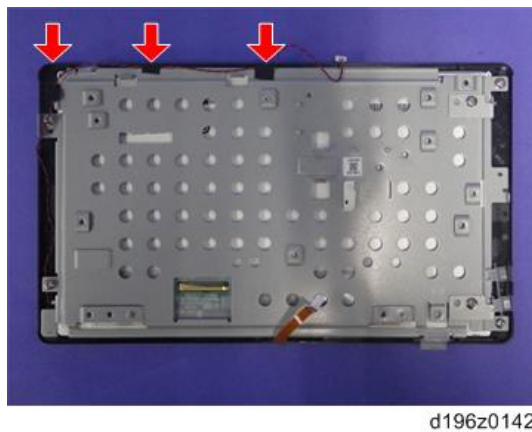

### 8. LCD [A] (⚙️ x4)

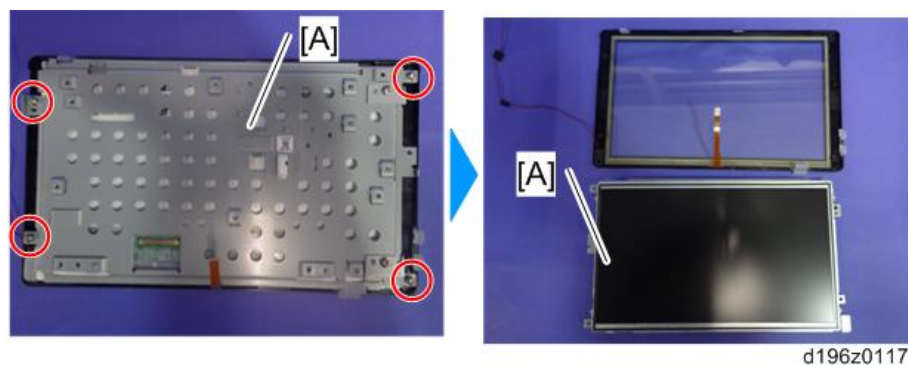

#### Note

- After replacing the LCD, perform the following checks.
  - LCD Check (page 47)
  - TouchPanel Check (page 49)
- Perform "TouchPanel Calibration" and "MultiTouch Calibration" of the Self Check function.

## 1.1.6 SPEAKER

1. Operation panel unit (page 1)
2. Bottom cover [A] (🔩 x4)

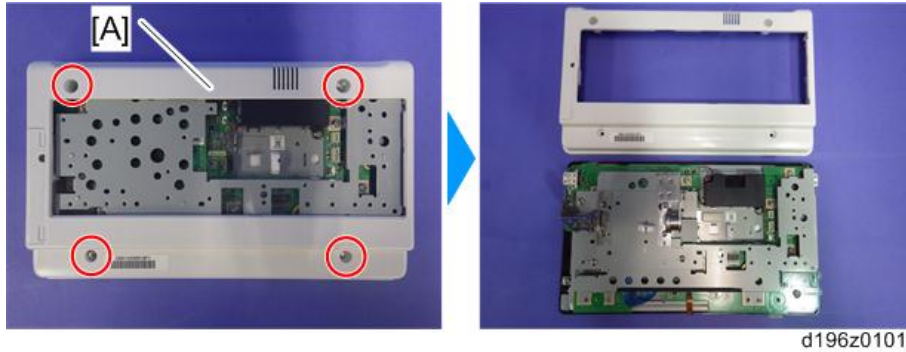

3. Speaker [A] (🔩 x2, 📦 x1)

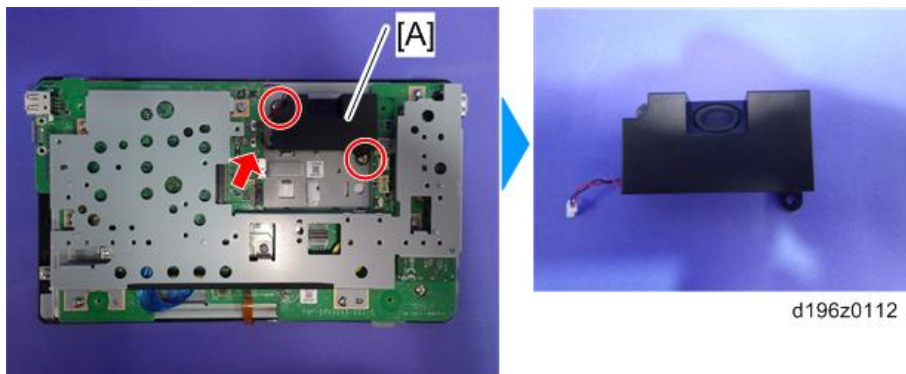

### ⓘ Note

- After replacing the speaker, perform the following check.
  - Speaker Check (page 48)

### 1.1.7 MICROPHONE

1. Operation panel unit (page 1)
2. CPU board (page 3)
3. Micro computer board (page 6)
4. Lift up the securing wire of the LCD I/F cable.

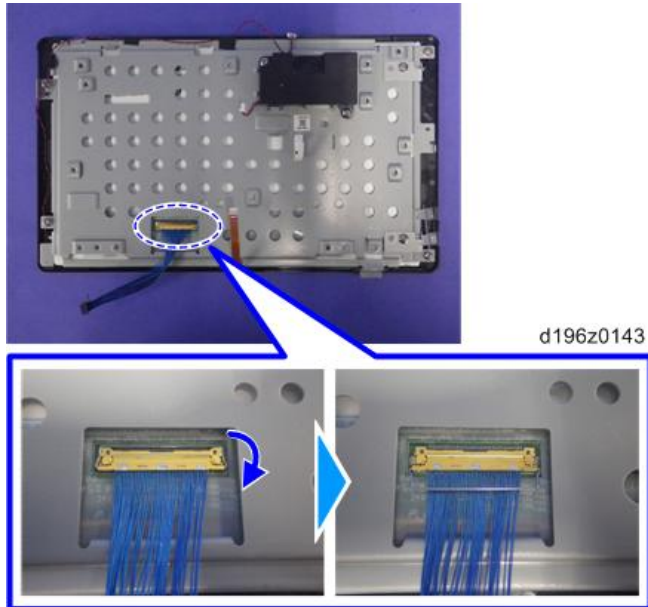

5. LCD I/F cable (cable x1)

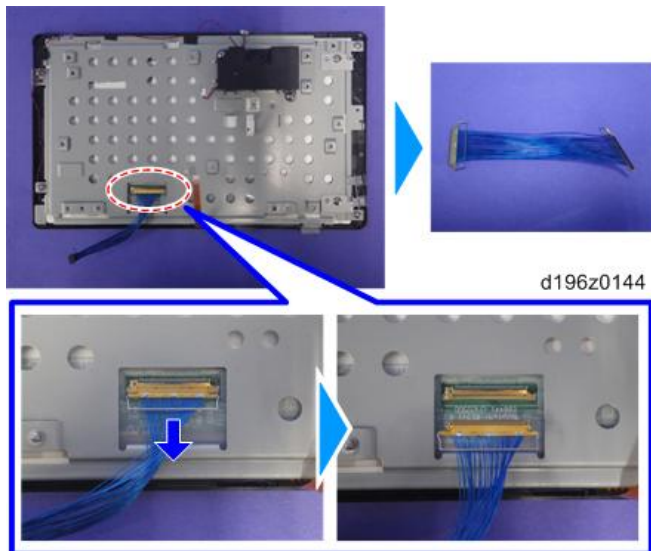

6. Remove the tapes for fixing the microphone harness (tape x3).

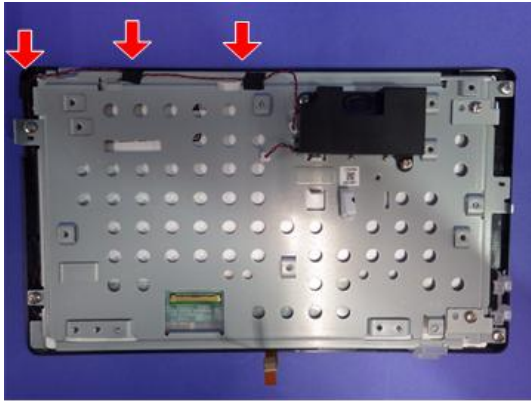

d196z0114

7. LCD [A] (🔑 x4)

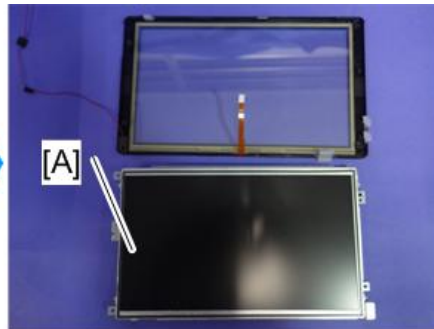
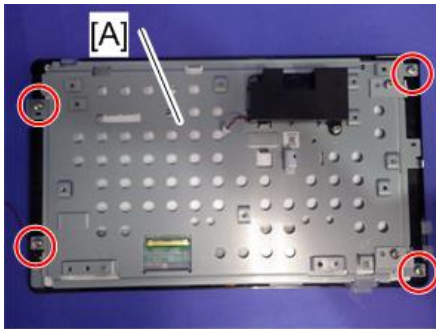

d196z0118

8. Microphone [A] (cushioning x1)

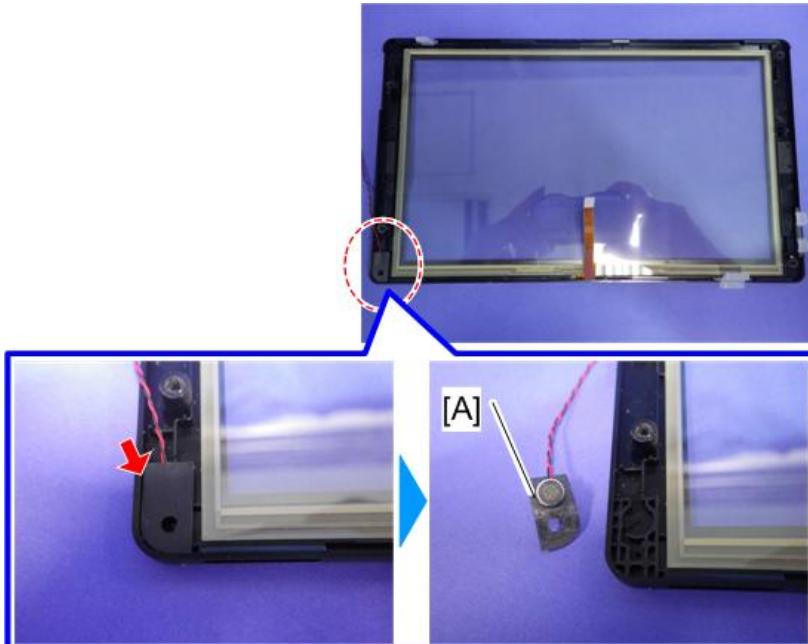

d196z0111



## 2. MECHANISM

### 2.1 OVERVIEW

#### 2.1.1 SYSTEM COMPONENTS

##### *Hardware Specifications*

##### Components

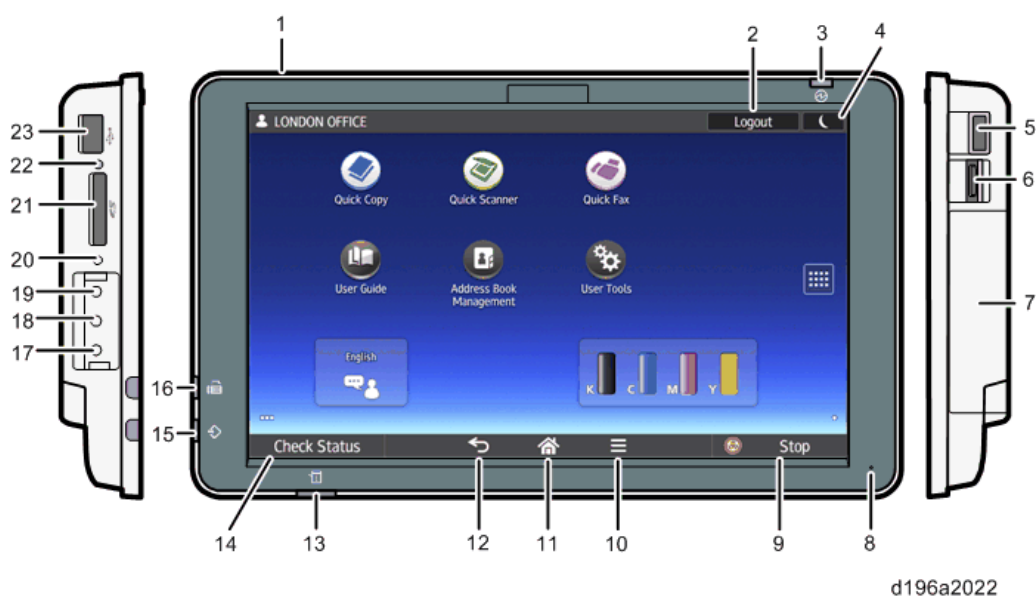

d196a2022

No.	Name	No.	Name
1	Speaker	13	[Check Status] indicator
2	[Login/Logout] key	14	[Check Status] key
3	Main power indicator	15	Data In indicator (facsimile and printer modes)
4	[Energy Saver] key	16	Fax indicator
5	USB slot for digital cameras	17	Extended Feature key (EX3)
6	HDMI slot	18	Extended Feature key (EX2)
7	USB slot for NFC card readers	19	Extended Feature key (EX1)
8	Microphone	20	Control panel reboot key
9	[Stop] key	21	SD card slot

No.	Name	No.	Name
10	[Menu] key	22	Media access lamp
11	[Home] key	23	USB slot
12	[Back] key		

### Basic Specifications



Category	Specification
LCD panel	<ul style="list-style-type: none"> <li>▪ Size 10.1 inch panel</li> <li>▪ Resolution WSVGA (1024x600)</li> <li>▪ Bit width RGB666 (18 bit color)</li> <li>▪ Brightness 200cd/m<sup>2</sup> (typ.)</li> <li>▪ Backlight LED Backlight (life: 15,000 hours)</li> </ul>
CPU	ARM Cortex-A9 Dual Core 1GHz (SoC: MCIMX6D5EYM10AC)
Touch panel	Low load touch panel (recognizes touches to two points)
Memory	<ul style="list-style-type: none"> <li>▪ Volatile Memory RAM (DDR3-1066), 2G</li> <li>▪ Non-Volatile Memory eMMC NAND, 8GB</li> </ul> <p><b>Note</b></p> <ul style="list-style-type: none"> <li>▪ Uses a 16GB product in SLC Mode.</li> <li>▪ Program area and data area for the operating system and applications.</li> </ul>

## Overview

Category	Specification
External interfaces	<ul style="list-style-type: none"> <li>▪ USB Memory USB2.0 Host Type-A</li> <li>▪ SD Card SD card slot 1ch (SD*<sup>1</sup>/SDHC*<sup>2</sup>) *1 Up to 2GB *2 Up to 32GB</li> <li>▪ USB expansion USB2.0 Host Type-A (for camera, USB keyboard, USB card reader)</li> <li>▪ USB expansion USB2.0 Host Type-miniB (for NFC expansion)</li> <li>▪ HDMI HDMI 1.4 (for large screens available as custom order)</li> </ul>
Internal interfaces	<ul style="list-style-type: none"> <li>▪ Extended Features microSD card slot</li> </ul>
Network	<ul style="list-style-type: none"> <li>▪ Wireless LAN 802.11b/g/n</li> <li>▪ Bluetooth Bluetooth4.0</li> </ul>
Audio input/output	Monaural speaker 1ch (output: 1 to 2 W), Microphone
RTC accuracy	±52.56 seconds per month (using external crystal oscillator, 20 ppm)
Hard keys	<ul style="list-style-type: none"> <li>▪ Extended Feature keys (EX1, EX2, and EX3) Use for startup in extended mode etc.</li> <li>▪ Control panel reboot key Use to reboot the control panel when it freezes.</li> </ul>

Category	Specification
LED types	<ul style="list-style-type: none"> <li>▪ Main power indicator (blue) Lights when the power is on. Flashes slowly in Sleep mode.</li> <li>▪ [Check Status] indicator lamp (red/blue) Lights when an error occurs.</li> <li>▪ Data In indicator (blue) Flashes when the machine receives data from a printer driver or LAN-Fax driver.</li> <li>▪ Fax indicator (blue) Flashes while sending or receiving a fax. Lights when there is a received fax document in the fax memory.</li> <li>▪ Media access lamp (blue) Lights when there is an SD card inserted in the SD card slot.</li> </ul>
Maximum power consumption	4 W or less (excluding external interfaces and internal feature expansions)
Power consumption in Sleep mode	0.35 W or less (When in Sleep mode, power is not supplied to USB devices connected to the USB slots.)

### Specification comparison with the previous model

Item	This model	Previous model
Appearance	 d196a2016	 d196a2017
Control panel size (Width x Height)	267 x 160 mm	345 x 161 mm
CPU operating frequency	1 GHz	533 MHz
RAM size	2 GB	1 GB
LCD panel size	10.1 inch	10.1 inch

Item	This model	Previous model
Android OS	Version. 4.2	Version. 2.3
Types of the following keys <ul style="list-style-type: none"> <li>▪ [Home] key</li> <li>▪ [Stop] key</li> <li>▪ [Check Status] key</li> <li>▪ [Back] key</li> <li>▪ [Menu] key</li> </ul>	Soft keys	Hard keys
LED types	Four types <ul style="list-style-type: none"> <li>▪ Main power indicator</li> <li>▪ [Check Status] indicator</li> <li>▪ Data In indicator</li> <li>▪ Media access lamp</li> </ul>	Seven types <ul style="list-style-type: none"> <li>▪ Main power indicator</li> <li>▪ [Check Status] indicator</li> <li>▪ Data In indicator</li> <li>▪ Media access lamp</li> <li>▪ [Home] key</li> <li>▪ [Menu] key</li> <li>▪ [Back] key</li> </ul>
Wireless LAN interface	IEEE802.11bgn	IEEE802.11bgn
Types of external interfaces	<ul style="list-style-type: none"> <li>▪ USB port (type A/mini)</li> <li>▪ USB media slot</li> <li>▪ SD card slot</li> </ul>	<ul style="list-style-type: none"> <li>▪ USB port (mini)</li> <li>▪ USB media slot</li> <li>▪ SD card slot</li> </ul>
Bluetooth	Available	Not available

**Available languages**

Japanese, English, French, German, Italian, Spanish, Dutch, Norwegian, Danish, Swedish, Polish, Portuguese, Hungarian, Czech, Finnish, Simplified Chinese, Traditional Chinese, Russian, Greek, Korean, Catalan, Turkish, Brazilian Portuguese

**Software Specifications**

A software package consisting of the Android Firmware and the manufacturer’s own pre-installed applications is installed on the Smart Operation Panel.

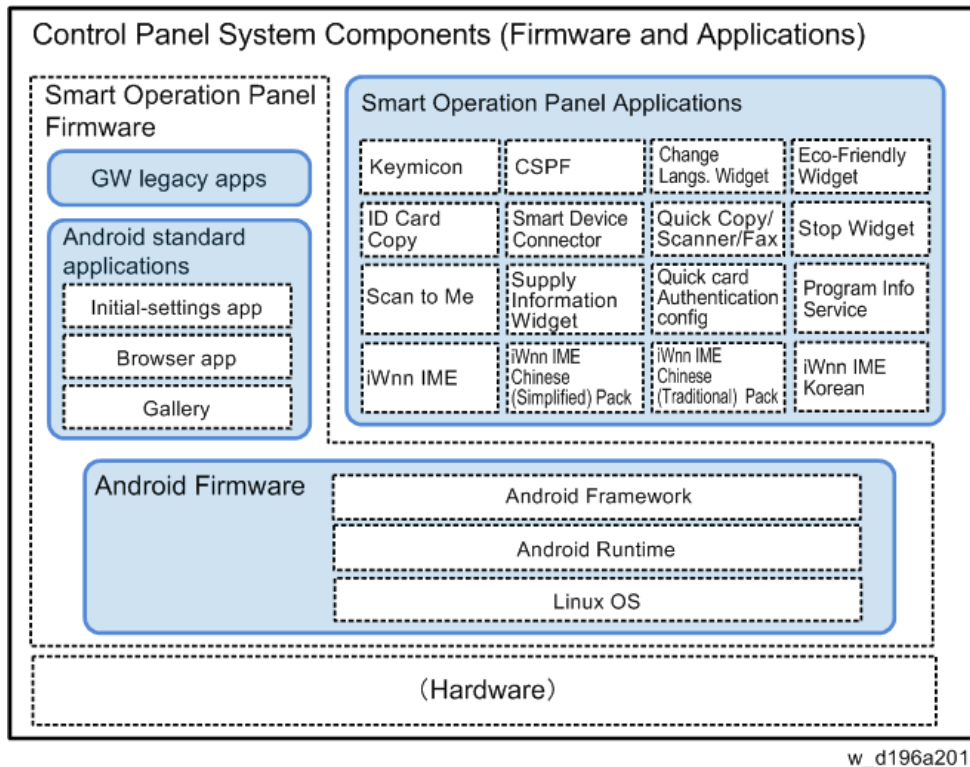

The following three types of software are installed on the Smart Operation Panel.

1. Android Firmware (Android OS)
2. Pre-installed applications
3. Applications that can be installed additionally

### Android Firmware (Android OS)

The Android Firmware (Android OS) consists of the following modules that are called “stacks”.

- Linux kernel
- Android Runtime
- Library
- Application Framework

### Pre-installed applications

On the Smart Operation Panel, applications such as the GW applications (Copy/Printer/Document Server/Scanner/Fax), Control Panel Browser, the standard keyboard, Installer, Gallery, Self Check are pre-installed. Unlike those installed on the controller board of the MFP, GW applications that are installed on the Smart Operation Panel are for controlling operation and display of the Smart Operation Panel.

Pre-installed applications are provided as part of the control panel firmware (Cheetah System) together with the Android firmware. When you update the control panel firmware using the recovery mode or another method, the pre-installed applications will also be updated.

**Applications that can be installed**

On the Smart Operation Panel, applications can be installed in addition to the pre-installed applications.

Applications that can be installed include optional applications that customers can purchase, applications that are installed only on machines sold in specific regions, and custom-made applications.

On an MFP, applications such as Simple UI applications (Quick Copy, Quick Fax, and Quick Scanner) and Scan to Me are installed.

**Communication specifications**

The Smart Operation Panel and the GW controller are connected by a USB 2.0 cable. They communicate with each other via the Android OS on the Smart Operation Panel, using protocols called “OCS Library” and “Flair-API (System/Application)”.

**System block diagram**

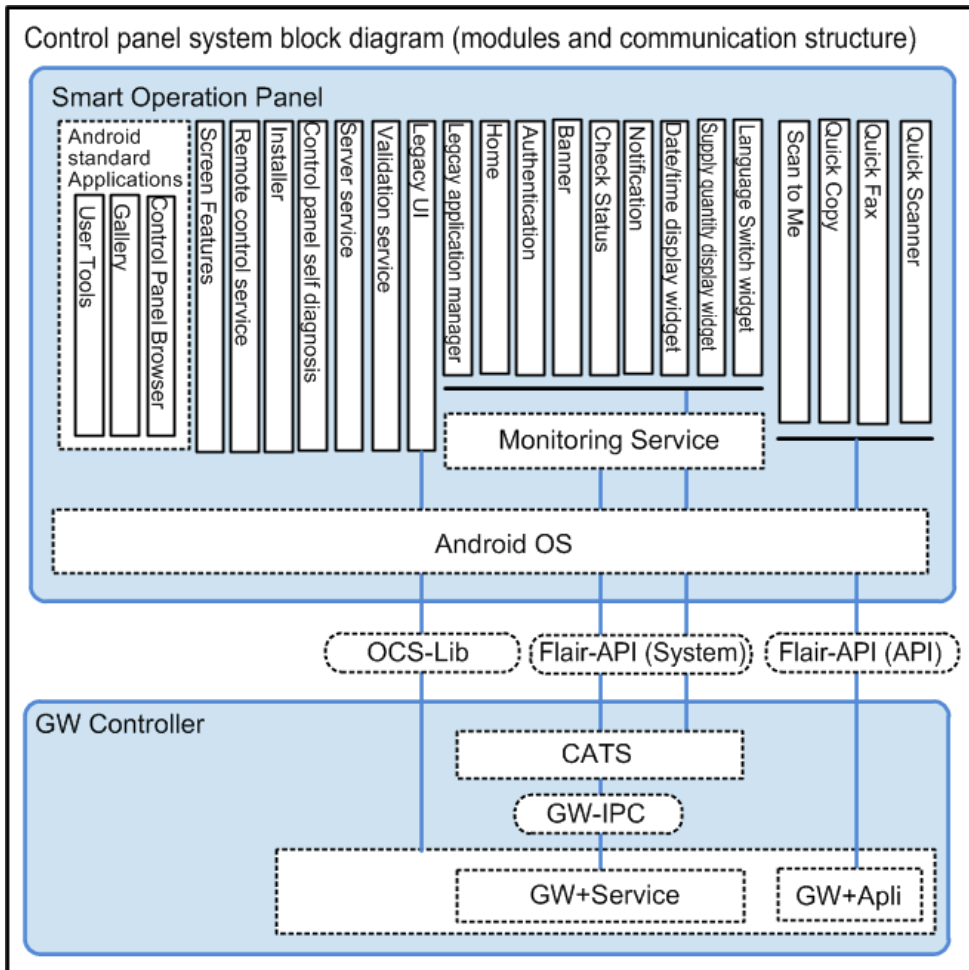

w\_d196a2015

## Overview of Components

Communication module/signal name	Details
OCS Library	<p>OSC stands for Operating Control Service. It is a module that controls the control panel. The set of signals used by this module to control the control panel are called the OCS Library. It is used during communication between the Legacy UI (system) module on the Smart Operation Panel and the GW module for the following processes.</p> <ul style="list-style-type: none"> <li>▪ Deciding on the display format suitable for a particular model of the control panel, so that the intended image data can be converted to actual image data.</li> <li>▪ Converting touch panel operations to commands.</li> </ul>
Flair-API (System/Application)	<p>Flair is the manufacturer's own communication interface between software modules. The interface uses a generic WebAPI.</p> <p>It is divided into two parts: a part that communicates directly with applications such as the application manager, Home, Authentication, Banner, Check Status, and Widgets, and a part that monitors applications. It communicates with the GW controller via the CATS module.</p>
CATS	<p>CATS stands for Cheetah Application Total System. It is a module in the GW controller.</p> <p>Because the Smart Operation Panel uses the Android OS, the contents and protocols of communication are not the same as those of the conventional control panel. CATS serves as an intermediary between the GW controller and the Smart Operation Panel.</p> <p>It also controls the power status of the control panel.</p> <p>CATS communicates with the Smart Operation Panel using the Flair-API, and communicates with the GW module using the GW-API.</p>
GW-IPC	<p>The name of the interface used among modules in the GW controller. The role is the same as that of the Flair-API.</p>



## Overview

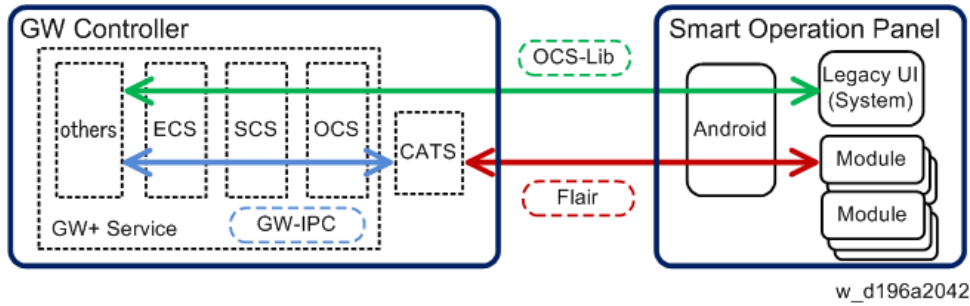

### Note

- API stands for Application Programming Interface. An API is an interface that software modules use in order to communicate with each other.

## Application Specifications

The pre-installed applications and applications that can be additionally installed on the Smart Operation Panel can be classified into the following 3 categories.

- **System applications**  
Applications that operate in conjunction with multiple functions (operating regardless of the application)
- **Program applications**  
Applications that provide a single additional function
- **Widget applications**  
Applications that provide a widget

The following table explains the function of each application.

Application	Functions
Settings	Provides the Android OS's standard settings.
Screen Features	Provides the manufacturer's own settings.
Authentication	Monitors login to/logout from the MFP, and transmits authentication information to other services and applications.
Monitoring service	Monitors the status of the MFP. This service is used by widgets and applications including Banner, Check Status, Authentication, and Home.
Launcher (Legacy Application Manager)	This application provides an application switching function when there is no Home application.
Installer	Provides the installer UI. Internal operation is controlled by the Package Installer application.

Application	Functions
Server service	Provides server functions for application installation.
Remote control	Works together with the server service and provides the functions and displays of RFU and import/export of settings, including the UI.
Manual	Provides connection to the server where manuals are stored (HTTP server). Manuals are displayed using the Web Browser application.
Splash screen	Provides the image that is displayed immediately after the MFP is turned ON.
Startup animation	Provides the startup animation for the operation screen.
Validation	Performs validation when the machine is started in CC certified mode. * CC stands for Common Criteria. It is the evaluation criteria for IT security (ISO15408).
LUI system	LUI stands for Legacy User Interface. The conventional control panel display is displayed by this application. Model-specific settings are included in this application
Package Installer	Provides installation and update functions for applications. Also provides the screen for uninstallation.
Self Check	Provides a self-check function for the control panel hardware. See page 45 "Panel Self Check" for contents of the self-check.
Initialization	Initializes settings of the MFP or the control panel.
Web Browser	Android OS's standard Browser application
Gallery	Reads images from SD cards or other media, and sets them as wallpaper or live wallpaper.
Standard keyboard	Android OS's standard operation panel that is called up when the user enters characters or numbers.

Application	Functions
Home screen	Provides the Home screen. Also provides screen customization and application switching.
Banner	Displays balloon messages in the banner area at the bottom of the panel display.
OCS emulator	This application serves as an intermediary between the control panel and the controller board. (The emulator allows the controller board to work the same way regardless of the type of control panel.)
Simple UI applications	<p>Simple (Quick) applications.</p> <ul style="list-style-type: none"> <li>▪ Quick Copy Provides the Quick Copy function.</li> <li>▪ Quick Fax Provides the Quick Fax function.</li> <li>▪ Quick Scanner Provides the Quick Scanner function.</li> </ul>
Widgets	<p>Resident applications that display information on the screen as configured.</p> <ul style="list-style-type: none"> <li>▪ Date/time indicator Displays the date and time.</li> <li>▪ Supply information Displays toner status.</li> <li>▪ Change Languages Provides the language switching function.</li> <li>▪ Eco-friendly Displays detailed information about the eco functions.</li> <li>▪ Fax Received File Displays the fax reception status.</li> <li>▪ Stop Provides a [Stop] key on the application screen. Used by functions such as Quick Copy and Scan to Me.</li> </ul>

Application	Functions
IME (excluding the standard keyboard)	<p>Multiple settings can be configured (the user can select one when using the keyboard).</p> <ul style="list-style-type: none"> <li>▪ iWnn IME Chinese (Simplified) Pack Chinese (simplified) language pack for iWnnIME</li> <li>▪ iWnn IME Chinese (Traditional) Pack Chinese (traditional) language pack for iWnnIME</li> <li>▪ iWnn IME Korean Pack Korean language pack for iWnnIME</li> </ul>
NFC dispatcher	<p>Host application for NFC (Near Field Communication). Transmits card information to authentication applications.</p>
Quick Card Authentication	<p>Provides simple authentication using an IC card.</p>
Standard IC card plugin	<p>A plugin for using IC cards. Examples of IC cards are the FeliCa (Lite) and Mifare card systems.</p>

## 2.1.2 PANEL COMPONENTS/SCREEN LAYOUT

### Components of the Control Panel

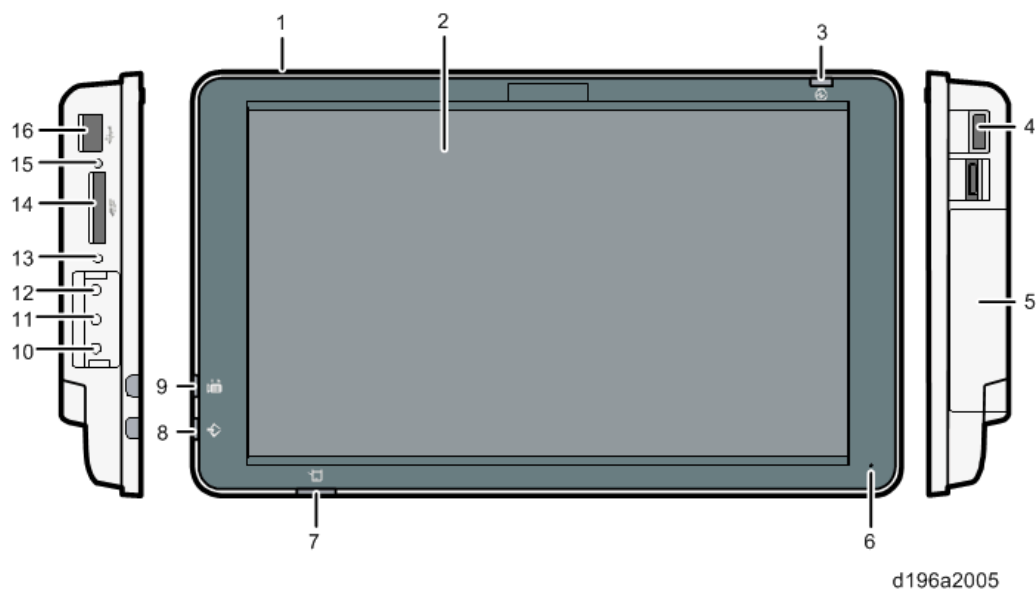

No.	Name	Description
1	Speaker	There is currently no function that uses this.
2	Display panel	Displays icons for functions and applications. Displays the operation screens, operation keys and other information.
3	Main power indicator	Indicates power OFF/ON status.
4	USB slot for digital cameras	A digital camera can be connected here.
5	USB slot for NFC card readers	A near field communication (NFC) device can be connected here.
6	Microphone	There is currently no function that uses this.
7	[Check Status] indicator	Indicates system status.
8	Data In indicator	Flashes when the machine receives data from a printer driver or LAN-Fax driver.

No.	Name	Description
9	Fax indicator	<p>Indicates fax status.</p> <ul style="list-style-type: none"> <li>▪ During communication: Flashes</li> <li>▪ When fax documents have been received using Substitute Reception: Lights</li> <li>▪ When the machine has received a confidential fax document: Lights</li> </ul>
10	Extended Feature key (EX3)	Used for system maintenance, such as control panel self-check.
11	Extended Feature key (EX2)	Used for system maintenance, such as control panel self-check.
12	Extended Feature key (EX1)	Used for system maintenance, such as control panel self-check.
13	Control panel reboot key	Used when rebooting the control panel.
14	SD card slot	Insert an SD card here.
15	Media access lamp	Lights when an external media is inserted into the SD card slot or the USB slot.
16	USB slot	Insert a USB memory device here.

## Panel display

### Screen Layout

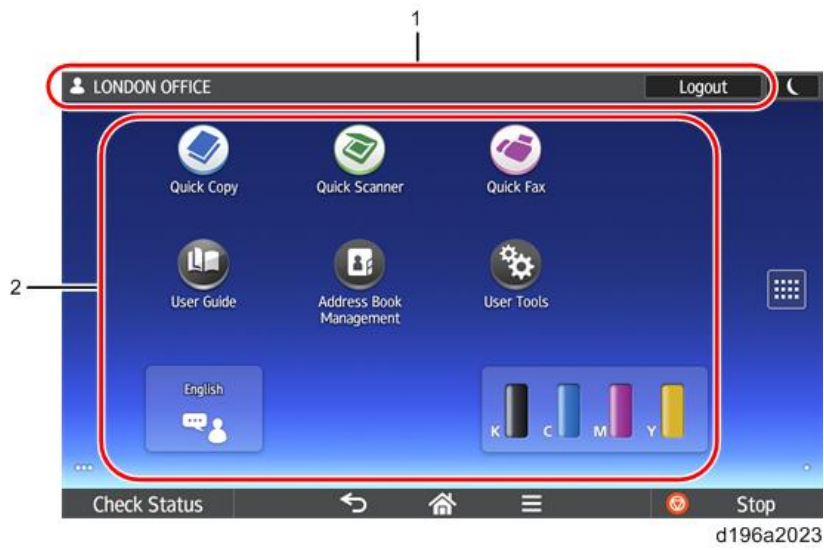

No.	Name	Description
1	Login information area	Login information is displayed.
2	Icon display area	Application icons, widgets, and system messages are displayed.

Soft keys displayed on the screen

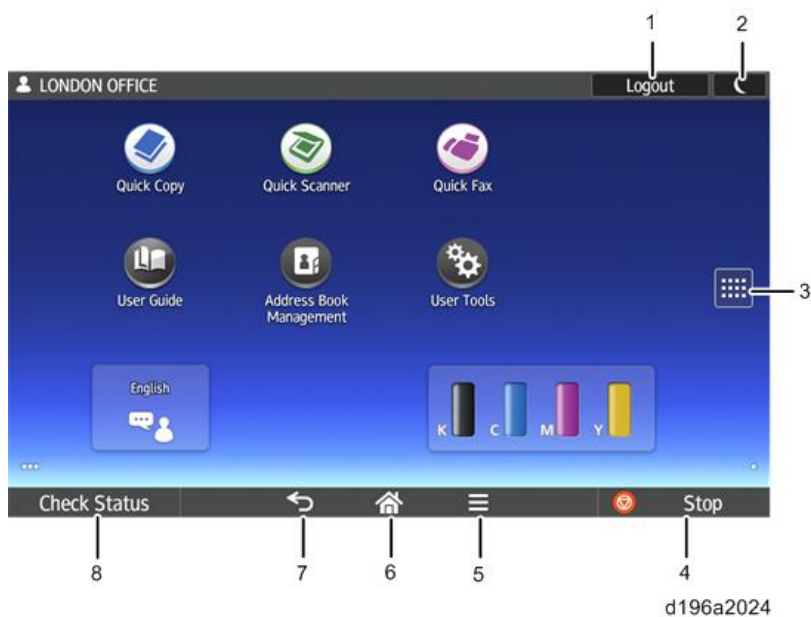

No.	Name	Description
1	[Login/Logout] key	Displayed when authentication is enabled. The login screen appears if you press [Login]. [Logout] is displayed if you have already logged in. You will be logged out when you press [Logout].
2	[Energy Saver] key	Enters Sleep mode.
3	[Application List] key	Displays the list of installed applications.
4	[Stop] key	Stops the scanning of a document, fax transmission, or printing to paper.
5	[Menu] key	Displays the menu screen of the application in use. May not be available depending on the application.
6	[Home] key	Displays the Home screen.
7	[Back] key	Use this to go back to the previous screen when the Screen Features screen or the screen of an application is displayed.
8	[Check Status] key	You can check the status of the MFP, each function, and the current job. You can also check the job history and maintenance information of the MFP.



## 2.1.3 ELECTRICAL COMPONENTS

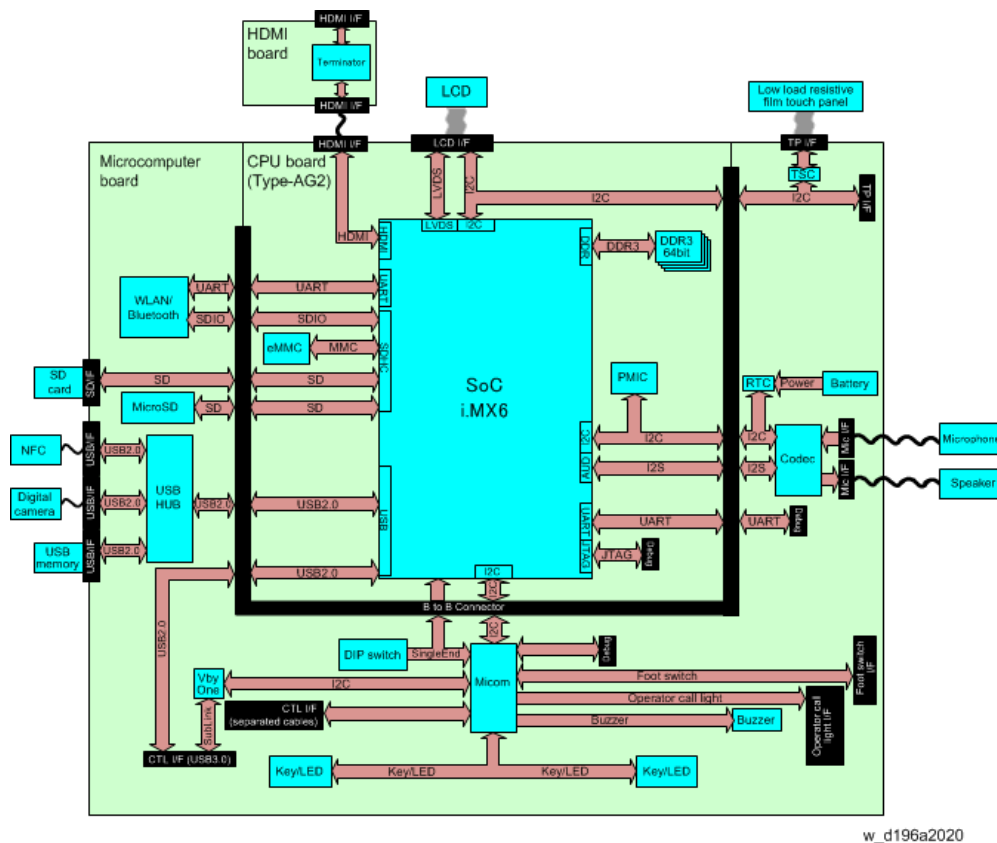

### Note

- The CPU board has a CPU, memory, and a flash drive.
- The Microcomputer board has various interfaces, Wi-Fi module and other devices.

### Touch panel

The touch panel of this machine uses a 4-wire resistive film method (low load resistive film analog 4-wire method). It can detect two points for flick/drag/pinch-in/pinch-out operations. Resistive touch panel has been adopted in order to allow operation with a prosthetic hand.

### Basic Structure

An analog 4-wire resistive film touch panel has 2 layers. Two materials (mainly film or glass) with transparent conductive film (ITO) are attached such that the transparent conductive film layers face each other.

When the film is pressed with a finger or a pen, the transparent conductive films contact each other and the touch panel operation is recognized.

Insulators (spacing dots) secure space between the two transparent conductive film layers to prevent short-circuiting.

Because the transparent conductive film has a uniform resistance characteristic, the resistance value reflects the distance of contact.

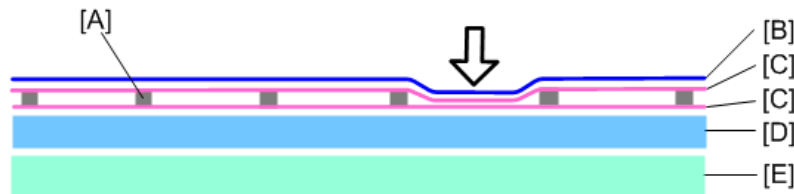

d196a2008

- [A]: Spacing dot
- [B]: PET film
- [C]: Transparent conductive film
- [D]: Base glass
- [E]: LCD panel

**Self-Check (multi-touch calibration) mechanism**

With the Multi-touch calibration in the self-check function, the touch panel is automatically calibrated using the results of touches to the top left and bottom right positions.

The values of “EVR\_X”, “EVR\_Y”, “X\_MAX”, and “Y\_MAX” are used for internal processing. They do not indicate the positions or distance of the touched points. There is no problem unless there is a huge difference between the values of the first calibration and the second calibration.

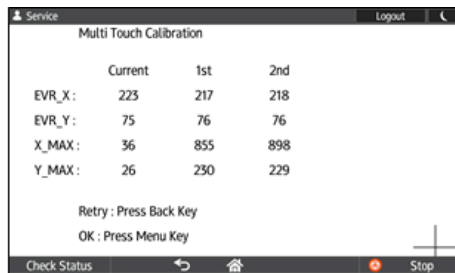
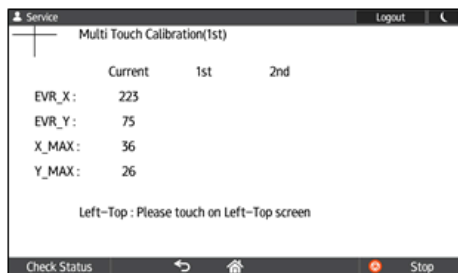

d196a2025

## 2.2 CONTROLLING THE POWER SUPPLY

### 2.2.1 EXITING ENERGY SAVING MODES

Because this model of Smart Operation Panel has no hardware keys, the MFP exits from energy saving mode when the user does one of the following:

- Touches the display panel
- Lifts the ADF
- Sets an original in the ADF

With the Smart Operation Panel, recovery from energy saving modes differs from that of the conventional control panel as follows.

	Smart Operation Panel		Conventional control panel
	This model	Previous model	
[Home] key	Not available	The machine exits the energy saving mode and displays the [Home] screen.	The machine does not exit the energy saving mode.
[Check Status] key	Not available	The machine exits the energy saving mode and displays the [Check Status] screen.	The machine exits the energy saving mode and displays the [Check Status] screen
[Energy Saver] key	Not available	Not available	The machine exits the energy saving mode and displays the screen selected in Function Priority <sup>*1</sup> .
[Back] key	Not available	The machine exits the energy saving mode and displays the [Home] screen.	Not available

	Smart Operation Panel		Conventional control panel
	This model	Previous model	
[Menu] key	Not available	The machine exits the energy saving mode and displays the [Home] screen.	Not available
[Stop] key	Not available	The machine exits the energy saving mode and displays the [Home] screen.	The machine does not exit the energy saving mode.
[Login/Logout] key	Not available	Not available	The machine does not exit the energy saving mode.
Touching the display panel	The machine exits the energy saving mode and displays the [Home] screen.	The machine exits the energy saving mode and displays the [Home] screen.	The machine does not exit the energy saving mode.
Lifting the ADF	The machine exits the energy saving mode and displays the [Home] screen.		
Setting an original in the ADF	The machine exits the energy saving mode and displays the [Home] screen.		

\*1 When exiting Low Power mode, the machine displays the screen of the function that had been selected before entering Low Power mode.

## 2.2.2 SCREEN STARTUP MODE

### *Startup Modes*

There are two screen startup modes. The factory default setting is Normal.

1. Normal

This is the standard startup mode. When the main power of the MFP is turned ON, the control panel starts up using less power compared to Quick mode.

2. Quick

By preparing for the next startup when the machine shuts down, the control panel starts up faster than in Normal mode.

### *Changing the Screen Startup Mode*

Screen Startup Mode can be changed in Screen Features.

Select [Screen Features] > [SYSTEM] > [Screen Device Settings] > [Screen Startup Mode], and then select [Normal] or [Quick].

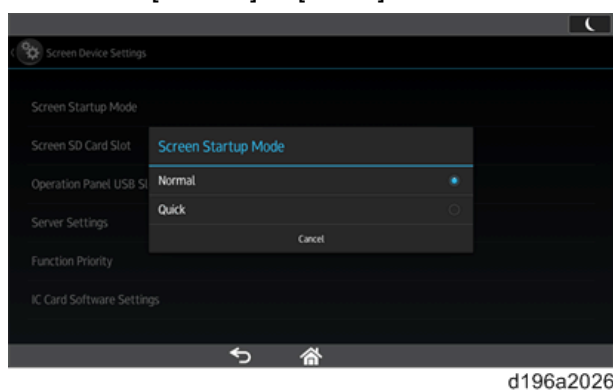

#### **Note**

- In the following cases, the control panel starts up in Normal mode even if [Quick] is selected.
  - The power cord has been disconnected from the power outlet after the last shutdown.
  - The MFP is turned ON after being turned OFF due to reasons such as a power failure.
  - The MFP was not properly shut down the last time it was turned OFF.

## How the Control Panel Starts Up

### In Normal mode

The startup screen is displayed on the display panel, followed by the startup animation.

Startup screen



Startup animation

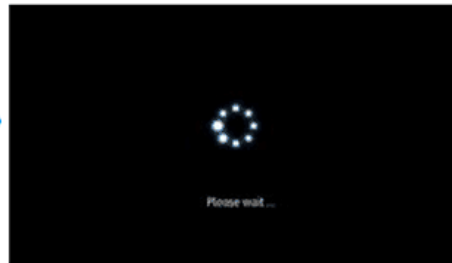

w\_d196a2019

### In Quick mode

The [Home] screen is displayed immediately after the main power of the MFP is turned ON.

The startup screen displayed when starting in Normal mode is not displayed.

## How the Screen Shuts Down When Quick mode Is Selected

When Quick mode is selected, the MFP prepares for the next startup when it shuts down. The main power indicator flashes during preparation for the next startup. The indicator turns off when preparation is completed.

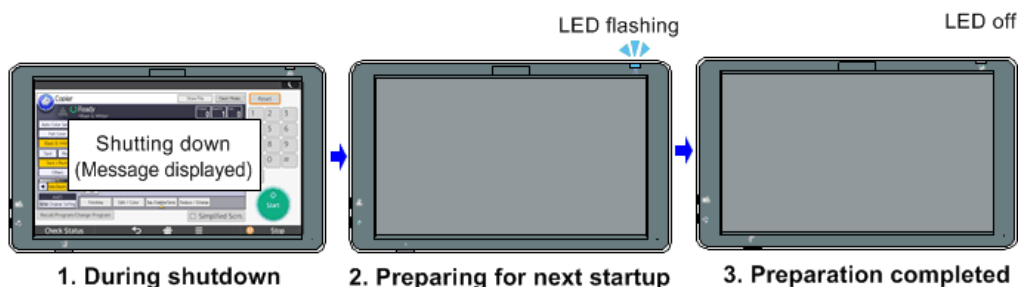

w\_d196a2004

If the MFP is turned ON during shutdown, the preparation for the next startup continues. When preparation for the next startup is completed, the control panel starts up in Quick mode.

### Note

- When Quick mode is selected, the control panel starts up faster than in Normal mode but shutdown takes longer than in Normal mode.

## 2.2.3 SHUTDOWN FUNCTIONS

### ***Normal Shutdown***

The MFP is equipped with a function to shut down safely in order to:

- Prevent damage to the file systems in the HDD and the NAND flash memory.
- Prevent paper from being left inside the body of the MFP (except when paper is jammed).

If the main power switch is a rocker switch, the shutdown process begins when the rocker switch is moved to the OFF position.

If the main power switch is a push switch, the shutdown process begins when the switch is pressed. To make a forced shutdown, press and hold the push switch for 6 seconds. However, if you force a shutdown during the shutdown process, data being processed may be lost. Forced shutdown is to be used to shut down the MFP without disconnecting the power cord when the shutdown process cannot be completed.

### ***Other Shutdown Functions***

This MFP has two additional shutdown functions to facilitate maintenance.

#### **Shutting down the MFP for parts replacement (Starting up in Normal mode when Quick mode is selected)**

When Quick mode is selected, the MFP prepares for the next startup when it shuts down.

This causes the shutdown process to take longer than when Normal mode is selected.

If you need to disconnect the power cord after shutdown in order to replace parts or for other reasons, you can use the following procedure to shut down the MFP just like you do in Normal mode. This shortens the time it takes to shut down the MFP.

- Procedure  
Turn the main power switch OFF while holding down the [Stop] key on the control panel.  
Continue to hold down the [Stop] key until the shutdown screen is displayed.

#### **Shutting down the MFP for software updates (Shutting down the MFP with the control panel in Sleep mode)**

If you are going to turn ON the MFP within 5 minutes, you can use the following procedure to shut down the MFP with the control panel in Sleep mode.

- Procedure  
Turn the main power switch OFF while holding down the [EX1] key. Continue to hold down the [EX1] key until the shutdown screen is displayed.

#### **Note**

- You must turn ON the MFP within 5 minutes.
- If more than 5 minutes has elapsed after shutting down the MFP using the above procedure, the machine starts up in Normal mode even if Quick mode is selected.

## 3. SYSTEM MAINTENANCE

### 3.1 SYSTEM MAINTENANCE

#### 3.1.1 MAINTENANCE MODES

Service program (SP) modes for the Smart Operation Panel are as follows:

Mode	Use	Notes
SP Mode (MFP)	SP modes for the MFP (controller, engine)	The numeric keys are required to enter this mode. Display the soft keys of the GW application or of the SP mode.
Service mode (control panel)	SP modes for the Smart Operation Panel. <ul style="list-style-type: none"> <li>▪ Changing SP mode settings in the Screen Features menu.</li> <li>▪ Installing and updating applications that can be installed</li> </ul>	Same as above
Recovery mode	Maintenance modes for the Android OS <ul style="list-style-type: none"> <li>▪ Updating firmware</li> <li>▪ Initializing all data</li> </ul>	-



### 3.1.2 LOGIN TO/LOGOUT FROM CONTROL PANEL SERVICE MODE

#### **Login**

In the same way as you log in to the SP Mode on the MFP, you use the soft keys to enter a combination of numbers in order to login to the service mode of the control panel.

#### **Note**

- You cannot log in to the service mode of the control panel when one of the following screens is displayed.
  - Stop All Jobs
  - User Tools
  - Address Book Management

Use the numeric keys on one of the following screens.

- Soft keys on the GW application screen
- Soft keys for the control panel's service mode (displayed by pressing both the [EX3] key and [Check Status] at the same time)

#### **Note**

- To exit the soft keys, press [EXIT] on the screen.

#### **Login Status Indicator**

When you log in to the control panel's service mode, the Screen Features screen is displayed.

- "Service" is displayed in the login information area [A].
- [Logout] is displayed in the Login key area [B] to allow logout from the service mode.

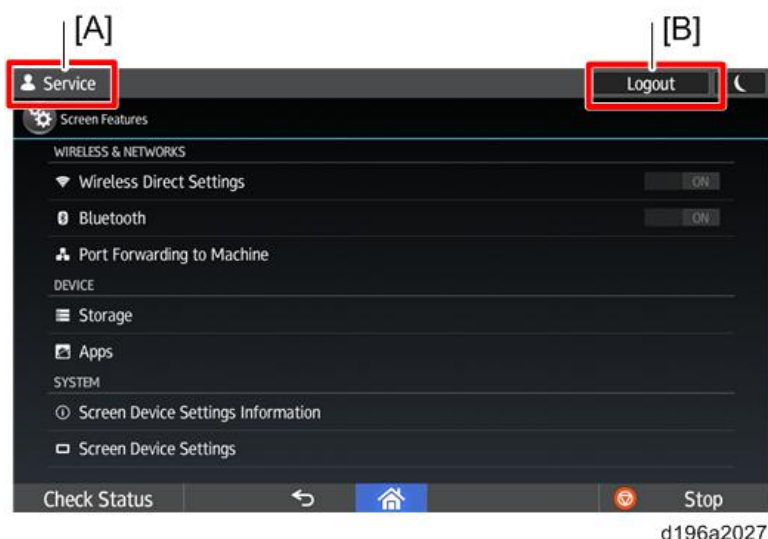

## Logout

Press [Logout] to log out from the control panel's service mode.

### Note

- You need to logout manually because the Auto Logout function does not work.

Depending on the authentication settings of the MFP, the following screen is displayed when you log out.

Authentication settings		
Administrator authentication: OFF User authentication: OFF	Administrator authentication: ON User authentication: OFF	Administrator authentication: ON User authentication: ON
Screen of the function selected in [Function Priority]	Screen of the function selected in [Function Priority]	[Home] screen

## When Entry to Service Mode Is Prohibited by the Administrator

The administrator of the MFP can prohibit entry into the control panel's service mode by enabling [Service Mode Lock] in [System Settings].

When [Service Mode Lock] is enabled, the machine does not enter the service mode even if you enter the number combination for the control panel's service mode. There will be no error messages or beeping sounds to indicate login failure.

### Note

- The machine can enter the recovery mode even if [Service Mode Lock] is enabled.

### 3.1.3 SERVICE MODE MENU

You can configure the following settings.

- WIRELESS & NETWORKS
- DEVICE
- SYSTEM

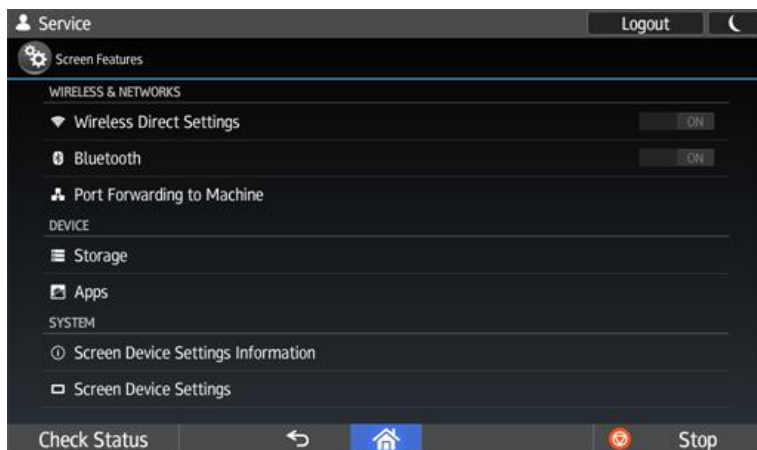

d196a2028

### WIRELESS & NETWORKS

Menu level			Description
1st level	2nd level	3rd level	
Wireless Direct Settings	Group Owner Mode		You can only view the setting.
	Connection Password		You can only view the setting.
	DHCP Server IP Address		You can only view the setting.
	DHCP IP Address Range		You can only view the setting.
	Select Channel		You can only view the setting.
	PEER DEVICES		View and configure devices that can be connected.

Menu level			Description
1st level	2nd level	3rd level	
	REMEMBERED GROUPS		Displays groups that have been previously connected.
Bluetooth	ON/OFF		You can only view the setting.
	SEARCH FOR DEVICES		Scans for Bluetooth devices in the vicinity.
	(name of this device)		You can only view the setting.
	PAIRED DEVICES		View and configure paired devices.
	AVAILABLE DEVICES		View and configure available devices.
Port Forwarding to Machine	Port Forwarding Settings	Port Forwarding Cinfo 1-20	Requests sent to the wireless LAN unit of the Smart Operation Panel can be forwarded to the controller of the MFP. You can enable or disable ports to forward these requests.

**DEVICE**

Menu level			Description
1st level	2nd level	3rd level	
Storage	INTERNAL STORAGE	Total space	Displays the total size of the internal storage.
		Available	Displays the available space of the internal storage.
		Apps (app data & media content)	Displays the size of applications in the internal storage.

## System Maintenance

Menu level			Description
1st level	2nd level	3rd level	
	SD CARD *1	Total space	Displays the total size of the SD card.
		Available	Displays the available space of the SD card.
		Apps (app data & media content)	Displays the size of applications in the SD card.
		Erase SD card	Erase data written to the SD card.
Apps	Install	Install from SD Card	Install or update applications from an SD card.
		Install from Server	Enter a product key to install or update applications from the server.
		Activate Applications	Activate applications that have been installed from the server.
		Update Applications	Update applications that have been installed.
		Uninstall	Uninstall applications.
		Check Server Connect	Check if you can connect to the Server.

\*1 Displayed only when an SD card is inserted into the SD card slot of the control panel.

**SYSTEM**

Menu level			Description
1st level	2nd level	3rd level	
Screen Device Settings Information	Status		Displays the following: <ul style="list-style-type: none"> <li>▪ Wi-Fi MAC address</li> <li>▪ Bluetooth address</li> <li>▪ Interface Settings</li> <li>▪ Wi-Fi settings (ON/OFF)</li> </ul>
	Legal information	Open source licenses	Displays the open source license information.
	Software Version List		Displays the versions of control panel firmware and installed applications. When saving the software version list on an SD card, insert an SD card into the SD card slot of the control panel, and then press [Save to SD Card].
Screen Device Settings	Server Settings	Port number	Input a port number for communication with the import/export and RFU server. The input number is used for both HTTP and HTTPS connections. (Normally, input a number within 55101-55111.)
	Application Settings		Displays a list of installed applications. If you press [Settings] for an application, the setting screen for the CE is displayed. The screen does not change if the application has no setting items.

Menu level			Description
1st level	2nd level	3rd level	
	Authentication priority mode	Authentication priority mode	<p>This setting gives priority to the recovery time from energy saving modes when an IC card authentication device is connected.</p> <p>When this setting is selected, the MFP does not enter Engine OFF mode, and always recovers from Silent mode.</p>
		Start time(hhmm)	<p>You can specify the start time of Authentication priority mode.</p> <p>* This can be changed only when [Authentication priority mode] is deselected.</p>
		Expiration time(hours)	<p>You can specify the period of validity of Authentication priority mode.</p> <p>* This can be changed only when [Authentication priority mode] is deselected.</p>
	Screen device always-connection Setting		<p>This setting prevents the control panel from entering Sleep mode, so that Bluetooth and other communication devices remain connected.</p> <p>When this setting is selected, the control panel does not enter Sleep mode. Only the LCD (display panel) turns OFF.</p>
	Panel Self Check		<p>Starts self-diagnosis of the control panel.</p> <p>(page 45 "Panel Self Check")</p>

### 3.1.4 PANEL SELF CHECK

The following are available as self-diagnostics functions of the control panel:

- LED Check
- Key Check
- LCD Check
- Speaker Check
- TouchPanel Check
- TouchPanel Calibration
- MultiTouch Calibration
- Wireless LAN Check
- Bluetooth Check

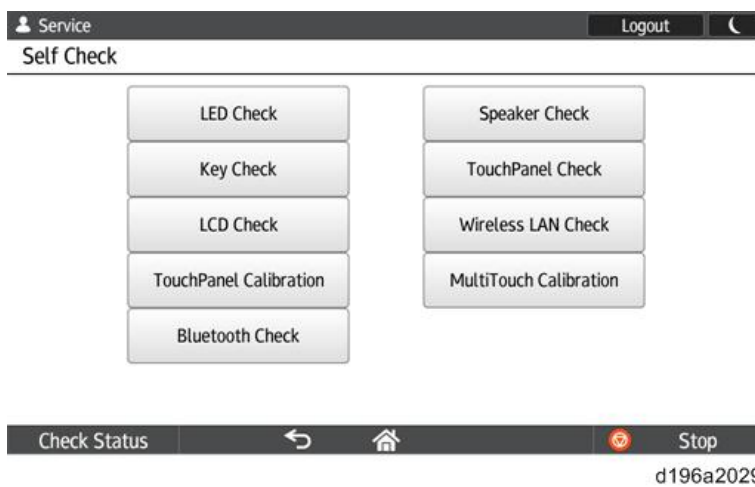

#### Note

- The [Self Check] menu is displayed in either English or Japanese. The language can be changed using [Change Language] in the Home screen.
- If an unavailable language is selected, English will be displayed.
- With some diagnostic items, press [Back] [A] at the bottom of the screen to return to the top menu of [Self Check].





### LED Check

Select the [All Light On] check box, and make sure the following LEDs light:

- Data In indicator (facsimile and printer modes)
- Fax indicator
- [Check Status] indicator (flashes in red and orange alternately)

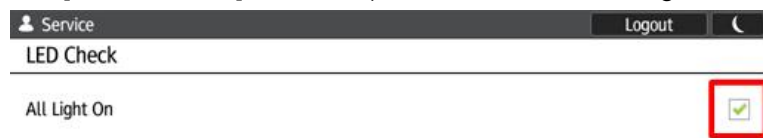

When the check is completed, press [Back] to return to the top menu of [Self Check].

### Key Check

Check if the Extended Feature keys on the left side of the control panel (EX1, EX2, EX3 from top to bottom) are functioning normally. If they are functioning normally, the key will turn green when pressed.

[FOOT SW] is not used.

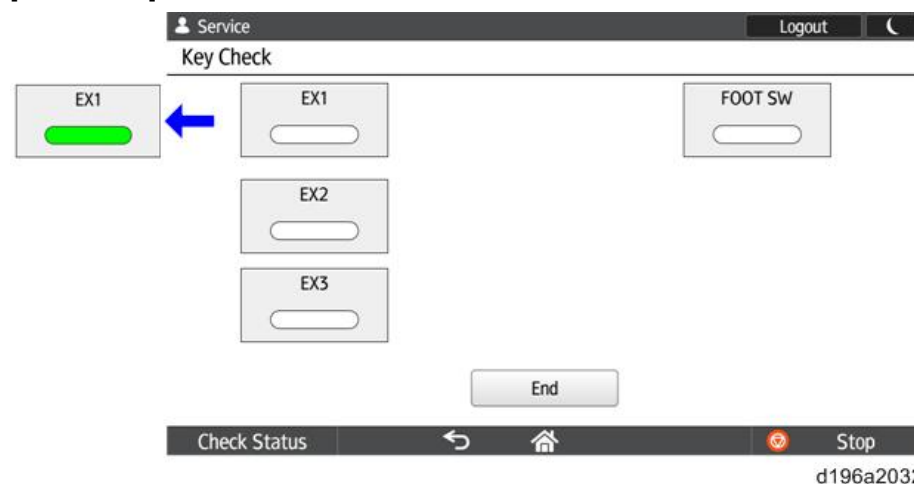

When the check is completed, press [End] to return to the top menu of [Self Check].

### **LCD Check**

Visually inspect the color of the LCD. The displayed colors are white/black/red/green/blue. The LCD changes to the next color when you press it.

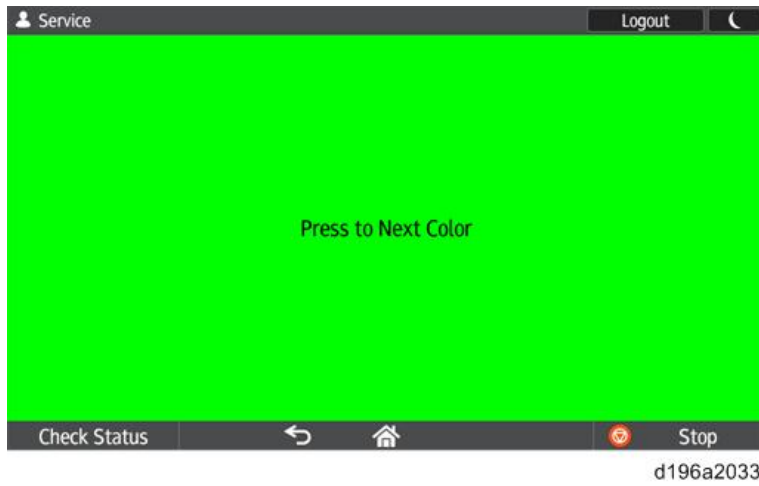

The check is completed when all colors have been displayed. The screen returns to the top menu of [Self Check].

## Speaker Check

Tests the speaker by playing the reference sound.

1. Select the frequency (220Hz, 440Hz, 880Hz, 1760Hz, or 2000Hz).
2. Press [START/STOP] to play the sound.
3. Touch the volume bar, and play the sound at minimum and maximum volumes.
4. Press [START/STOP] to stop the sound.



When the check is completed, press [Back] to return to the top menu of [Self Check].

### TouchPanel Check

For each of the nine reference points on the screen, the distance between the detected position and the nearest reference point is displayed.

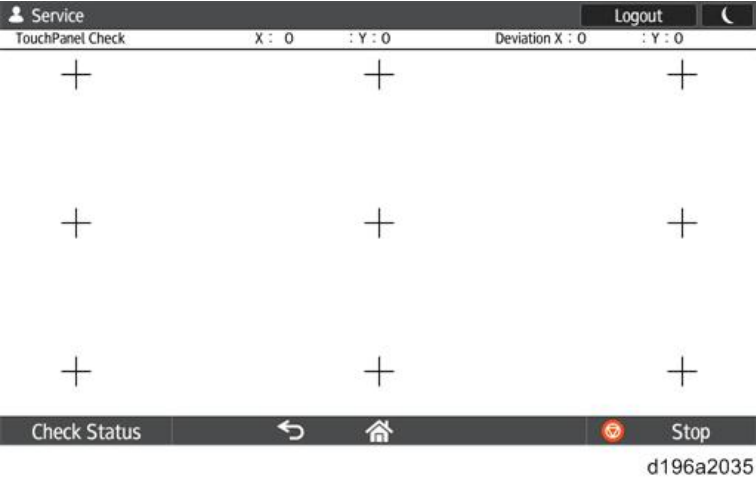

When the check is completed, press [Back] to return to the top menu of [Self Check].

### ***TouchPanel Calibration***

Calibrate the touch panel by touching the center of each of the five “+” signs.

The five “+” signs are displayed in the order of top left, bottom right, bottom left, center, and top right.

After you have touched the five “+” signs, the display switches to the [Retry/OK] screen.

- If you want to calibrate again, press [EX1].
- If you want to confirm the calibration results, press the [EX3] key to return to the top menu of [Self Check].



Retry : Press EX1 key  
OK : Press EX3 key



d196a2036

## MultiTouch Calibration

Calibrate the touch panel for multi-tap input methods such as pinch-in/pinch-out.

Touching the center of both “+” signs. The two “+” sign are displayed in the order of top left and bottom right. Repeat the procedure. The touch panel will be calibrated.

- If you want to adjust it again, press the [EX1] key.
- If you want to confirm the calibration results, press the [EX3] key to return to the top menu of [Self Check].

	Current	1st	2nd
EVR_X :	223		
EVR_Y :	75		
X_MAX :	36		
Y_MAX :	26		

Left-Top : Please touch on Left-Top screen

	Current	1st	2nd
EVR_X :	223	217	218
EVR_Y :	75	76	76
X_MAX :	36	855	898
Y_MAX :	26	230	229

Retry : Press Back Key  
OK : Press Menu Key

d196a2037

The “Back Key” in the message is actually the [EX1] key and the “Menu Key” in the message is actually the [EX3] key.

### Note

- The values of “EVR\_X”, “EVR\_Y”, “X\_MAX”, and “Y\_MAX” are for internal processing and do not indicate the positions or distance of the points touched. There is no problem unless there is a huge difference between the values of the first calibration and the second calibration.

## Wireless LAN Check

Checks the condition of the wireless LAN connection.

When you select the connected access point, the signal strength, IP address and other information are displayed.

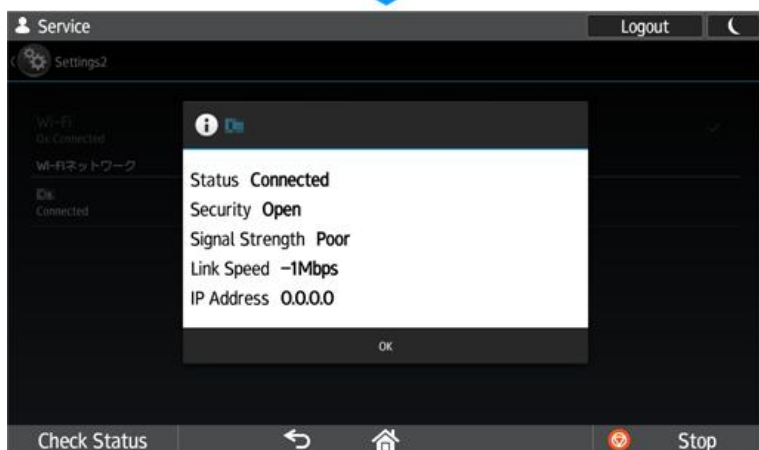
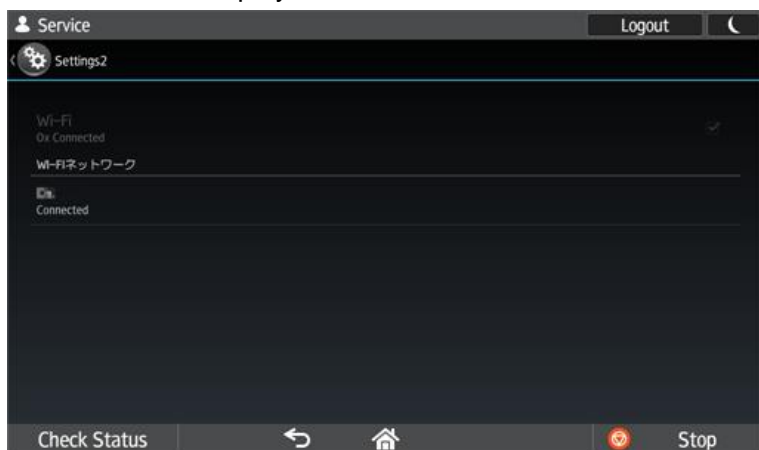

d196a2038

When the check is completed, press [Back] to return to the top menu of [Self Check].

## Bluetooth Check

Check and configure the Bluetooth device connection.

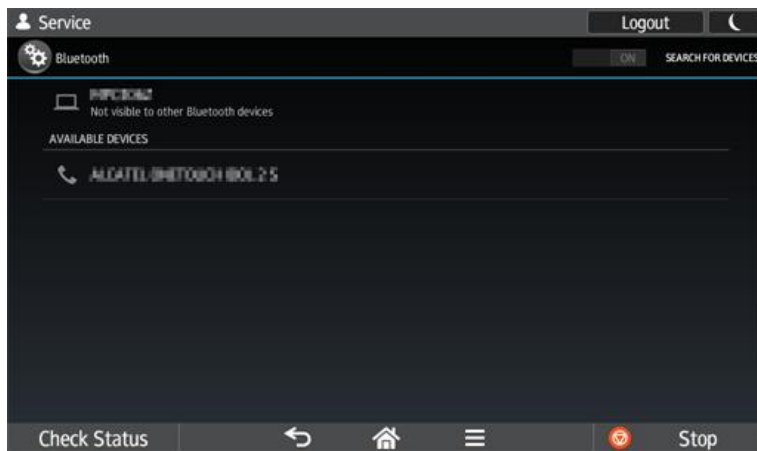

d196a2039

When the check is completed, press [Back] to return to the top menu of [Self Check].

### ⓘ Note

- You cannot switch Bluetooth to [ON] or [OFF] from the [Self Check] menu. Before checking the Bluetooth device connection, specify [ON] for [Bluetooth] in [Screen Features] > [WIRELESS & NETWORKS] > [Bluetooth].



### 3.1.5 RECOVERY MODE

The recovery mode menu is as follows. Ask your manager for details on how to enter Recovery mode.

Menu	Description
reboot system now	Reboots the Android OS.
apply update from sdcard	Updates the Cheetah System firmware by specifying the folder path.
wipe data/factory reset	Deletes all installed applications and all settings on the Cheetah-G1.
wipe cache partition	Deletes all data that is stored on the cache partition. Currently, Cheetah does not use the cache partition, so nothing happens when this menu item is accessed.
wipe free area partition	Deletes all data that is stored on the free partition. Cheetah stores the version history on the free partition. When this menu item is selected, it will then disappear.
wipe LegacyUI area	Deletes Legacy UI.
micon update from sdcard	Updates Keymicon by specifying the folder path.

#### Note

- If [Update Firmware] is set to [Prohibit] in [System Settings] of the MFP, the control panel cannot enter the recovery mode.
- Ask your manager for information on how to enter the recovery Mode.

## 3.2 SOFTWARE UPDATE

### 3.2.1 UPDATING THE SMART OPERATION PANEL

There are three methods to update the Smart Operation Panel. The method is different depending on what you want to update.

1. Installation/update from an SD card
2. Package update
3. Installation/update from the eDC Server

Update method	Features	Control panel firmware	Applications
Installation/update from an SD card	<p>Update using an SD card.</p> <ul style="list-style-type: none"> <li>▪ This is the only method to install an older version of currently installed software.</li> <li>▪ Enter the recovery mode to update the control panel firmware.</li> <li>▪ Use the installation screen in the control panel's service mode to update applications.</li> <li>▪ You can install or update multiple applications at once.</li> <li>▪ You can also uninstall an application.</li> </ul>	Yes	Yes
Package update	<p>Uses the Package update function of the GW+ controller to update the software.</p> <ul style="list-style-type: none"> <li>▪ The software is updated in the following order: controller firmware, applications, and then the control panel firmware.</li> <li>▪ The procedure for updating the control panel firmware is the same as when updating from an SD card using Recovery mode.</li> </ul>	Yes	Yes
Installation/update from the eDC Server	<p>Downloads applications from the eDC Server for installation or update.</p> <p>This method is mainly for paid applications. A product key is required when an application is installed for the first time.</p>	No	Yes

## Software Update

The following two methods can be used for updating the firmware.

- Update from an SD card (recovery mode)
- Package update

The following three methods can be used for updating an application.

- Installation/update from an SD card
- Package update
- Installation/update from the eDC Server

### 3.2.2 INSTALLATION/UPDATE FROM AN SD CARD

#### *Updating the Smart Operation Panel Firmware*

Enter the recovery mode to update the firmware of the Smart Operation Panel.

##### Note

- When [Quick] is selected for [Screen Startup Mode], the control panel cannot enter the recovery mode. Change the startup mode to [Normal]. When update is completed, restore the startup mode setting because the setting affects startup time.
- Shut down the MFP with [Normal] selected for [Screen Startup Mode], or shut it down using the special shutdown procedure used for maintenance.
- If [Prohibit] is selected for [Update Firmware] in [System Settings], the machine cannot enter Recovery mode. Ask the administrator of the MFP to change the setting.

#### Creating an SD card for firmware update

1. **Download the update module “Cheetah System” from the Firmware Download Center.**
2. **Execute the downloaded file.**

A file named “part number + suffix.zip” will be created.

##### Note

- Do not unzip the created file.

3. **Copy the “part number + suffix.zip” file to the root directory of the SD card.**

#### Updating the firmware (for the Cheetah System)

1. **Turn OFF the MFP.**

##### Note

- Shut down the MFP with [Normal] selected for [Screen Startup Mode], or shut it down using the special shutdown procedure used for maintenance.

2. **Insert the SD card into the SD card slot of the control panel and start up the MFP in Recovery mode.**

##### Note

- Ask your manager for details on how to enter the recovery mode.
- In the recovery mode, key functions are shown on the screen. However, the key functions for moving/selecting directories are different for executing an update. Check the key functions while operating.

Keys	When moving/selecting directories	When executing an update
[EX1]	Moves the cursor up.	Executes updating.
[EX2]	Moves the cursor down.	Cancels updating.
[EX3]	Selects the item.	

3. Select “apply update from sdcard” in the “Android system recovery” screen, and then press the [EX3] key.

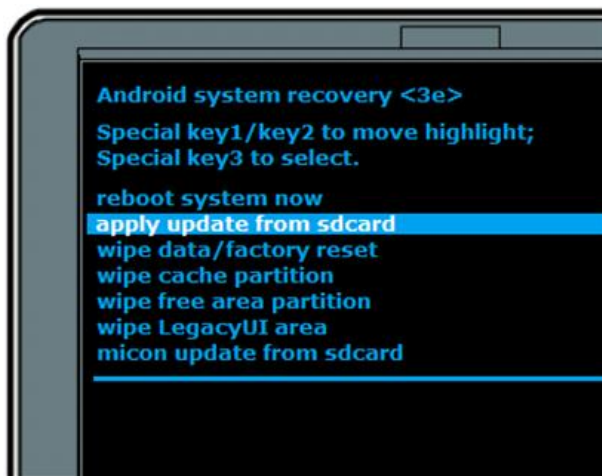

d196a2043

4. The contents of the SD card is displayed. Select “part number + suffix.zip” with the [EX1] or [EX2] key, and then press the [EX3] key.

Example: “D1961400A.zip”

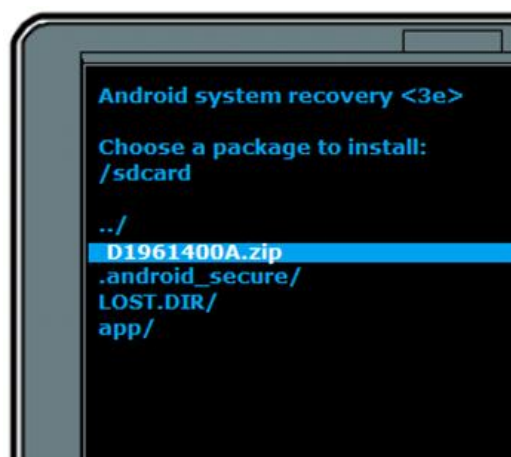

d196a2044

5. The installation screen is displayed.

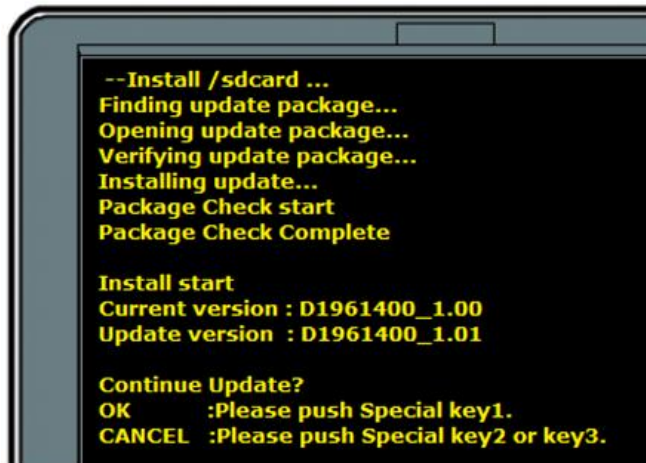

d196a2045

6. The version of the firmware installed in the control panel is displayed as “Current version” and the version of the firmware saved on the SD card is displayed as “Update version”. Make sure that you have the correct version.
7. When “Continue Update?” is displayed, press [OK] ([EX1] key).  
The update process starts.

**Note**

- To cancel the firmware update, press the [EX2] or [EX3] key.
8. When “Install from sdcard complete.” is displayed, select “reboot system now” and then press the [EX1] key to reboot the system.

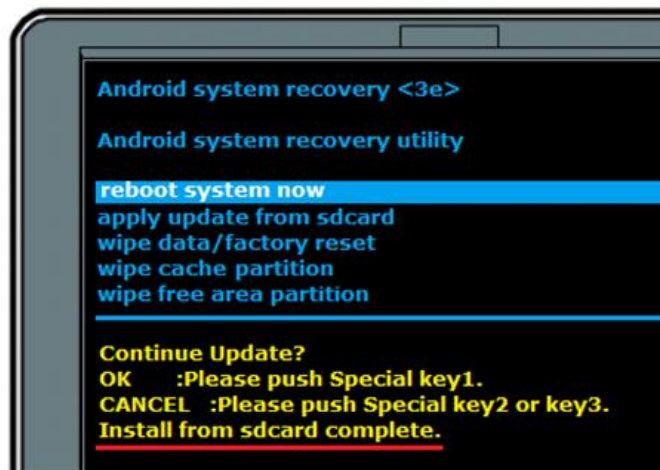

d196a2046

## ***Installing/Updating an Application***

### **Creating an SD card for update**

1. Download the update modules from the Firmware Download Center.
2. Unzip the downloaded file.
3. Create a folder named “romdata” in the root directory of the SD card.
4. Put the unzipped file in the “romdata” folder.

### **Update procedure**

1. Log in to the control panel in service mode.
2. Insert the SD card into the SD card slot of the control panel.
3. Select [Apps] > [Install] > [Install from SD Card].
4. Select the application you want to install or update, and then press [Install]
5. The installation or update results are displayed.
6. Check that the application is correctly installed or updated, and then press [reboot operation panel].

## **3.2.3 PACKAGE UPDATE**

This method uses the package update function to update the control panel firmware and/or applications. The package update function is provided by the controller.

Update is done in the following order:

1. Controller firmware
2. Applications
3. Control panel firmware

If the control panel firmware has to be updated, the control panel starts in the recovery mode and the firmware is automatically updated.

The control panel restarts when updating is completed. The result notification is processed after the control panel restarts.

### ***When Installation/Update Is Prohibited***

If [Prohibit] is selected for [Update Firmware] in [System Settings], the execution key is grayed out and installation/update cannot be executed.

When trying to update from a PC, updating fails and the result is recorded as “Failed”.

### 3.2.4 INSTALLATION/UPDATE FROM THE EDC SERVER

Downloads applications from the eDC Server, and installs or updates them.

This method is mainly for paid applications. A product key is required when an application is installed for the first time.

#### ↓ Note

- Installation/activation/update of applications from the server can only be done in the service mode.

#### **Check Server Connect**

1. Log in to the control panel's service mode.
2. Select [Apps] > [Install].
3. Press [Check Server Connect] and make sure that "Connect Server Succeeded!" is displayed.

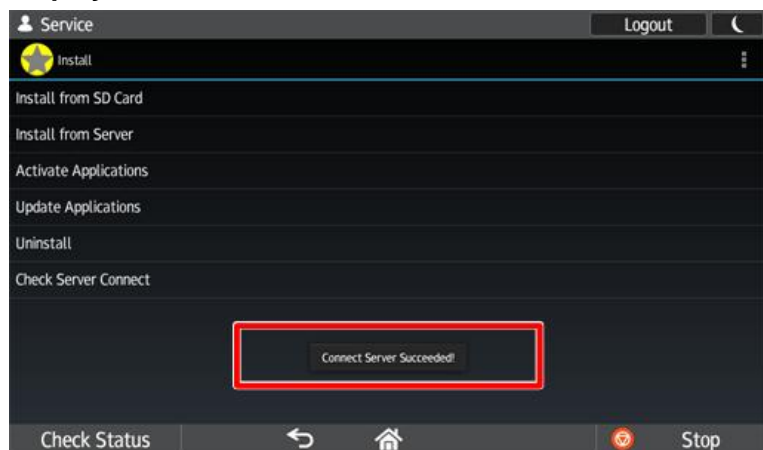

d196a2040

#### ↓ Note

- The server address is stored in the firmware of the Smart Operation Panel.
- To connect to the server, the network settings of the MFP must be configured correctly. For the required configuration, see the Field Service Manual of the MFP.
- If server connection fails, see page 63 "Troubleshooting" for error codes.

## Installation

1. Log in to the control panel's service mode.
2. Select [Apps] > [Install].
3. Select [Install from Server].
4. Enter the product key and press [Execute].

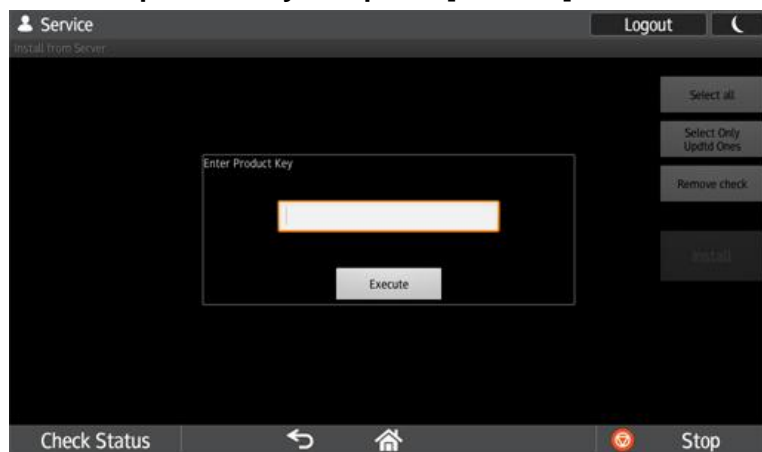

d196a2041

5. Follow the instructions shown on the screen.

### Note

- An application cannot be installed unless it is digitally signed by Ricoh.

## Activation

1. Log in to the control panel's service mode.
2. Select [Apps] > [Install].
3. Select [Activate Applications].
4. Select the application to be activated, and then enter the activation key and press [Execute].

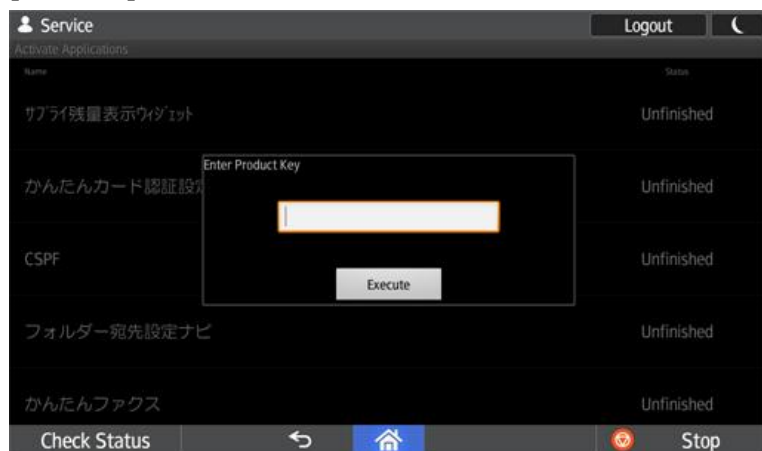

d196a2049

5. Follow the instructions shown on the screen.



## Software Update

### Note

- Except for onerous applications, there is no problem that the activation status is "Unfinished".

### ***Update***

1. **Log in to the control panel's service mode.**
2. **Select [Apps] > [Install].**
3. **Select [Update Applications].**
4. **Select the application to be updated, and then press [Check Update Status].**
5. **Follow the instructions shown on the screen.**

## 4. TROUBLESHOOTING

### 4.1 TROUBLESHOOTING

#### 4.1.1 SOFTWARE UPDATE ERRORS

*Errors that occur during application update from an SD card*

Error message / screen display	Explanation	Solution
Insert a correct SD card.	-	<ul style="list-style-type: none"> <li>▪ Remove the SD card and insert it again.</li> <li>▪ Make sure that the directory of the SD card is correct. You must create the "app" folder in the root directory of the SD card and put the zip file in the "app" folder.</li> </ul>
You are trying to install the same application with a different part number. Is it OK to continue?	Displayed when you attempt to update an application that is the same but has a different part number.	Check the file, and select [OK] or [Cancel].
Some applications could not be installed.	Displayed in the following cases. <ul style="list-style-type: none"> <li>▪ You attempted to update a module (application) in use.</li> <li>▪ The application is corrupted.</li> </ul>	Restart the control panel and repeat the update procedure.

## Troubleshooting

Error message / screen display	Explanation	Solution
- (The application you want to update is not displayed in the list of applications.)	-	<ul style="list-style-type: none"><li>▪ Make sure that the directory of the SD card is correct. You must create the "app" folder in the root directory of the SD card and put the zip file in the "app" folder.</li><li>▪ Check the application file in the SD card.</li></ul>

### Errors that occur during update from the eDC Server

Error code	Explanation
101	Server connection error
102	Signature verification error
103	License error (for example, the product key was keyed in wrongly)
215	Dependency check error Displayed when the control panel firmware version does not meet the installation requirement of the application. Example: The firmware version of the control panel is 1.02 and you attempted to install an application that requires firmware version 1.03.
20X	Other errors

#### Example of an error code display



d196a2048

#### Note

- An additional 3-digit code may be displayed to indicate the details.  
Example: 101-805

### **Errors that occur during remote (batch file) update**

When the update is completed, a result report file (install\_result\_yyyymmddhhmm.txt) is created in the same folder as the batch file.

The result report file shows the IP address of the MFP and whether the update process was successful or not. "yyymmddhhmm" shows the date and time according to the clock of the MFP.

Result	Explanation
Succeed	Updated the machine successfully.
Failed	Failed to update the machine. An error code follows.
Not connected	Failed to connect to the machine.
Can't get result	Failed to obtain the result (occurs only with firmware updates).

#### **Example of a result report file**

- Name: install\_result\_201512041005.txt
- Contents:
  - 192.168.0.100: Succeed
  - 192.168.0.102: Failed error:XX (XX indicates an error code.)
  - 192.168.0.103: Not connected

#### **Error codes**

The meanings of error codes recorded after "error:" in the result file are as follows:

##### **Error codes recorded during firmware update**

Error code	Explanation	Access Log
-2	Invalid file	Recorded
-3	The target application cannot be found.	Recorded
-501	Installation has already been requested.	Recorded (*1)
-602	Invalid signature	Recorded
-603	Updating is prohibited.	Recorded
-604	Failed to put the application offline.	Not recorded
-610	Authentication failed.	Not recorded

Error code	Explanation	Access Log
-699	Unknown error	Recorded (*2)
-701	Version of the micro computer firmware is invalid.	Recorded
-709	File structure error (invalid file)	Recorded
-710	Writing failure	Recorded

**Error codes recorded during application update**

Error code	Explanation	Access Log
-2	Invalid file	Recorded
-3	The target application cannot be found.	Recorded
-4	The storage capacity is not enough.	Recorded
-12	The version of the Android application cannot be installed.	Recorded
-602	Invalid signature	Recorded
-603	Updating is prohibited.	Recorded
-604	Failed to put the application offline.	Not recorded
-610	Authentication failed.	Not recorded
-699	Unknown error	Recorded (*2)

\*1 The error code recorded in the Access Log will be "223: machine-busy".

\*2 If the error occurs during preparation for configuration change, it will not be recorded in the Access Log.

**Note**

- If the preparation for configuration change (putting the application offline, authentication, file size check) cannot be carried out, an error code is displayed on the screen. However, it is not recorded in the Access Log as a firmware update/installation error.

**Error codes recorded in the Access Log**

Error code	Error name	Explanation	Solution
49	fwu-prohibit	Firmware update is prohibited.	Enable firmware update, and repeat the procedure.
60	other:E60	The HDD cannot be used.	<ul style="list-style-type: none"> <li>▪ Turn the main power OFF and ON, and then repeat the procedure.</li> <li>▪ If the HDD is damaged, replace it.</li> </ul>
62	other:E62	The structure of the application or control panel firmware in the package is invalid.	Prepare a valid package file.
221	terminate-fail	Failed to terminate an application when attempting to update or uninstall it.	<ul style="list-style-type: none"> <li>▪ If a job is under way in the target application, wait until the job is finished, and then repeat the procedure.</li> <li>▪ Turn the main power OFF and ON, and then repeat the procedure.</li> </ul>
222	signature-invalid	Failed to verify the signature attached to the application or firmware.	Repeat the procedure using a valid signature.
223	machine-busy	Failed to execute installation because another function was being used on the MFP.	<ul style="list-style-type: none"> <li>▪ Wait a while and repeat the procedure.</li> <li>▪ Turn the main power OFF and ON, and then repeat the procedure.</li> </ul>
224	capacity-lack	The storage capacity is not enough.	<ul style="list-style-type: none"> <li>▪ Reduce the number of applications to be installed.</li> <li>▪ Uninstall unnecessary applications.</li> </ul>

Error code	Error name	Explanation	Solution
225	download-fail	The product ID is incorrect.	Use a correct product key.
226	dependency-check-fail	The control panel does not meet the installation requirements of the application.	Check the installation requirements of the application. Update the control panel as necessary.
227	license-invalid	There are no remaining licenses. The product key that you are trying to use has already been activated for another device.	Use an unused product key to activate the application.
		An invalid product key was used to issue the license.	Update the application using an activated product key.
		The number of licenses issued has exceeded the limit.	Deactivate the application, and then activate it again.
		The license has expired. The product key being used is no longer valid.	Use an unused product key to activate the application.
		The license contract is invalid.	Use a valid product key to activate the application.
228	file-not-found *	The target firmware file cannot be found.	<ul style="list-style-type: none"> <li>▪ Turn the main power OFF and ON, and then repeat the procedure.</li> <li>▪ Check the file in the SD card.</li> <li>▪ Check the SD card slot. If there is a problem with the hardware, replace the control panel PCB.</li> </ul>



## Troubleshooting

Error code	Error name	Explanation	Solution
229	file-invalid *	<p>The target update file is invalid. Occurs in the following cases.</p> <ul style="list-style-type: none"> <li>▪ Failed to decompress the file.</li> <li>▪ Failed to obtain application information.</li> <li>▪ Failed to read the public key for signature verification.</li> </ul>	Repeat the procedure using a valid file.
230	wrong-folder-structure *	The folder directory of the control panel firmware is invalid.	Repeat the procedure using a valid directory.
231	write-fail *	<ul style="list-style-type: none"> <li>▪ Failed to write data when updating the control panel firmware.</li> <li>▪ There is a problem with the hardware.</li> </ul>	Turn the main power OFF and ON, and then repeat the procedure. If updating fails again, replace the control panel.
232	deactivate-fail	<p>The application could not be uninstalled because deactivation failed.</p> <ul style="list-style-type: none"> <li>▪ Failed to connect to the server.</li> <li>▪ The license has not been issued.</li> </ul>	<ul style="list-style-type: none"> <li>▪ Check whether the network is configured correctly.</li> <li>▪ If the server is under maintenance, wait a while and repeat the procedure.</li> <li>▪ Check the activation status of the application. If it has not been activated, activate it.</li> </ul>
233	uninstall-fail	Failed to uninstall an application.	Turn the main power OFF and ON, and then repeat the procedure. If updating fails again, replace the control panel.

Error code	Error name	Explanation	Solution
234	fixed-app	You attempted to uninstall an application that cannot be uninstalled.	Cancel uninstallation.
235	install-fail	The target file is invalid, and the Android OS returns an error.	<ul style="list-style-type: none"> <li>▪ Repeat the procedure using a valid file.</li> <li>▪ If the same application has already been installed, uninstall it and then repeat the procedure.</li> </ul>
236	sdk-incompatible	The Android SDK version required by the application is not installed on the control panel.	Check that the Android SDK version required by the application is installed on the control panel.
237	server-disconnect	Failed to connect to the eDC server.	<ul style="list-style-type: none"> <li>▪ Check the network connection (SSL) settings.</li> <li>▪ Check the proxy settings.</li> <li>▪ If the server is under maintenance, wait a while and repeat the procedure.</li> </ul>
255	panel-system *	Software malfunction.	Turn the main power OFF and ON, and then repeat the procedure.

\* These errors are not expected to occur.

### 4.1.2 ERRORS THAT OCCUR WHEN THE CONTROL PANEL DOWNLOADS DATA FROM THE CONTROLLER AT STARTUP

Some of the graphic data used in the control panel display is model-specific. Model-specific components are stored in the controller board of the MFP.

During startup, the control panel checks if it is necessary to update the model-specific data. If it is necessary, the control panel downloads the data from the MFP controller board and installs it in the control panel.

During update, a dialog appears to inform you that the settings are being changed. When the update process is completed, a dialog indicates whether update was success or not.

Error code	Explanation
E1	An error has occurred when downloading data from the controller board of the MFP.
E2	An error has occurred when installing data on the control panel. An additional error code is displayed after "E2".

# D3B3

## FAX OPTION TYPE M15

REVISION HISTORY		
Page	Date	Added/Updated/New
		None



# FAX OPTION TYPE M15 (D3B3)

## TABLE OF CONTENTS

<b>1. INSTALLATION .....</b>	<b>1</b>
1.1 FAX OPTION TYPE M15 (D3B3).....	1
1.1.1 ACCESSORY CHECK .....	1
1.1.2 INSTALLATION PROCEDURE .....	1
1.2 FAX UNIT OPTIONS.....	4
1.2.1 FAX CONNECTION UNIT TYPE M15 .....	4
Overview of Fax Connection Unit.....	4
Installing the application in the Remote Machine and Client-side Machine .....	5
Registering the Client-side Machine(s).....	7
Registering the Remote Machine.....	8
Configuring the Remote Reception Settings.....	10
Remote Fax Icon Addition for Remote Machine .....	12
<b>2. REPLACEMENT AND ADJUSTMENT .....</b>	<b>14</b>
2.1 FCU .....	14
2.1.1 SRAM DATA TRANSFER PROCEDURE .....	14
<b>3. TROUBLESHOOTING .....</b>	<b>17</b>
3.1 FAX CONNECTION UNIT ERROR CODES .....	17
3.1.1 FAX CONNECTION UNIT ERROR CODE LIST.....	17
MACHINE_ERR_01 .....	17
MACHINE_ERR_02 .....	17
MACHINE_ERR_03 .....	18
MACHINE_ERR_04 .....	18
MACHINE_ERR_05 .....	19
MACHINE_ERR_06 .....	19
MACHINE_ERR_07 .....	19
MACHINE_ERR_08 .....	20
3.2 ERROR CODES .....	21
3.3 IFAX TROUBLESHOOTING .....	42
3.4 IP-FAX TROUBLESHOOTING .....	45
3.4.1 IP-FAX TRANSMISSION.....	45
Cannot send by IP Address/Host Name .....	45
Cannot Send via VoIP Gateway .....	46
Cannot Send by Alias Fax Number .....	47





3.4.2	IP-FAX RECEPTION .....	49
	Cannot Receive via IP Address/Host Name. ....	49
	Cannot Receive by VoIP Gateway. ....	49
	Cannot Receive by Alias Fax Number. ....	51
<b>4.</b>	<b>SERVICE TABLES .....</b>	<b>53</b>
4.1	BEFOREHAND .....	53
4.2	SERVICE TABLES .....	54
4.2.1	SP1-XXX (BIT SWITCHES) .....	54
4.2.2	SP2-XXX (RAM) .....	55
4.2.3	SP3-XXX (MACHINE SET) .....	55
4.2.4	SP4-XXX (ROM VERSION) .....	56
4.2.5	SP5-XXX (RAM CLEAR) .....	57
4.2.6	SP6-XXX (REPORT) .....	58
4.2.7	SP7-XXX (TESTS) .....	60
4.3	BIT SWITCHES - 1 .....	61
4.3.1	SYSTEM SWITCHES.....	61
4.4	BIT SWITCHES - 2 .....	77
4.4.1	I-FAX SWITCHES.....	77
4.4.2	PRINTER SWITCHES.....	86
4.5	BIT SWITCHES – 3.....	94
4.5.1	COMMUNICATION SWITCHES .....	94
4.6	BIT SWITCHES – 4.....	106
4.6.1	G3 SWITCHES.....	106
4.7	BIT SWITCHES – 5.....	116
4.7.1	IP FAX SWITCHES .....	116
4.8	NCU PARAMETERS.....	125
4.9	DEDICATED TRANSMISSION PARAMETERS .....	129
4.9.1	PROGRAMMING PROCEDURE .....	129
4.9.2	PARAMETERS .....	130
	Fax Parameters.....	130
	E-mail Parameters.....	134
<b>5.</b>	<b>SPECIFICATIONS .....</b>	<b>138</b>
5.1	GENERAL SPECIFICATIONS .....	138
5.1.1	FCU .....	138
5.1.2	CAPABILITIES OF PROGRAMMABLE ITEMS .....	139
5.2	IFAX SPECIFICATIONS .....	140
5.3	IP-FAX SPECIFICATIONS.....	141
5.4	FAX UNIT CONFIGURATION.....	142

# READ THIS FIRST

## Symbols and Abbreviations

### Conventions Used in this Manual

This manual uses several symbols.

Symbol	What it means
	Screw
	Connector
	E-ring
	Clip ring
	Clamp

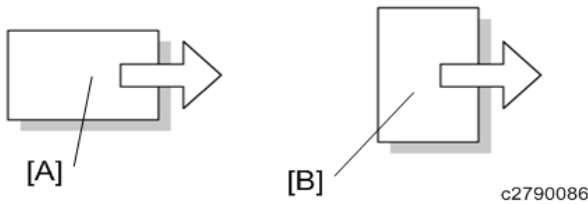

[A]: Short Edge Feed (SEF)

[B]: Long Edge Feed (LEF)

### Cautions, Notes, etc.

The following headings provide special information:

#### **WARNING**

- Failure to obey warning information could result in serious injury or death.

#### **CAUTION**

- Obey these guidelines to ensure safe operation and prevent minor injuries.

#### **Important**

- **Obey these guidelines to avoid problems such as misfeeds, damage to originals, loss of valuable data and to prevent damage to the machine.**
- **Always obey these guidelines to avoid serious problems such as misfeeds, damage to originals, loss of valuable data and to prevent damage to the machine. bold is added for emphasis.**

#### **Note**

This document provides tips and advice about how to best service the machine.





# 1. INSTALLATION

## 1.1 FAX OPTION TYPE M15 (D3B3)

### 1.1.1 ACCESSORY CHECK

Check the quantity and condition of the components against the following list.

No.	Description	Q'ty
1	Bracket	1
2	EMC address	1

### 1.1.2 INSTALLATION PROCEDURE

#### ⚠ CAUTION

- Unplug the machine power cord before starting the following procedures. Otherwise, it may result in an electric shock or a malfunction.

#### 1. Remove the T-shaped cover [A].



d205m4002

#### 2. Remove the screws of the rear cover [A].



x3

d205m4003

3. Open the right cover.
4. Remove the rear cover [A].

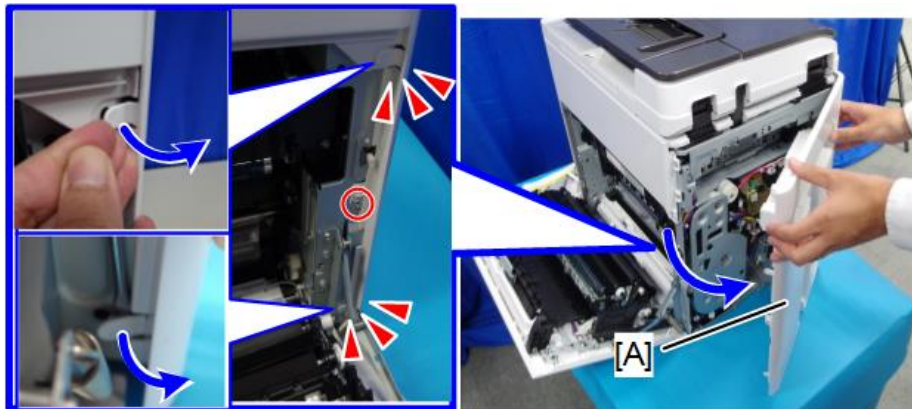

🔑 x1

d205m4005

⬇️ **Note**

- Be careful not to damage the tabs at the rear of the left cover when removing or installing the rear cover.

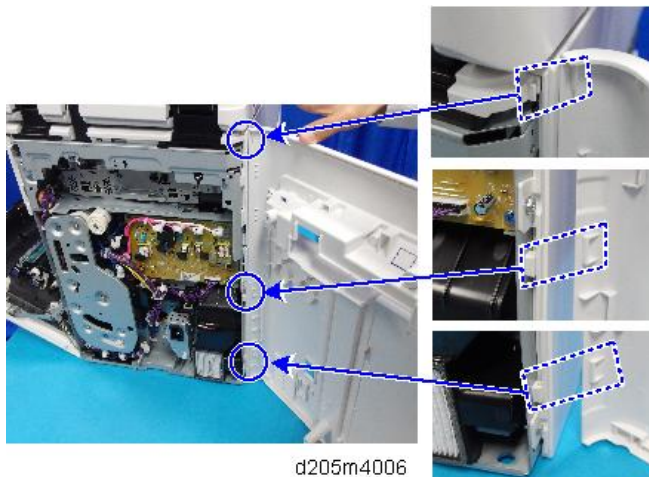

d205m4006

5. Remove the cover [A].

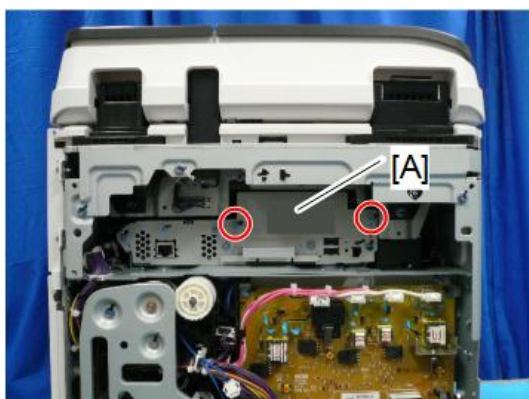

🔑 x2

d3b3k1000

6. Attach the bracket [A] to the Fax Unit.



 x2

d3b3k1001

**7. Install the Fax Unit [A] on the Machine.**

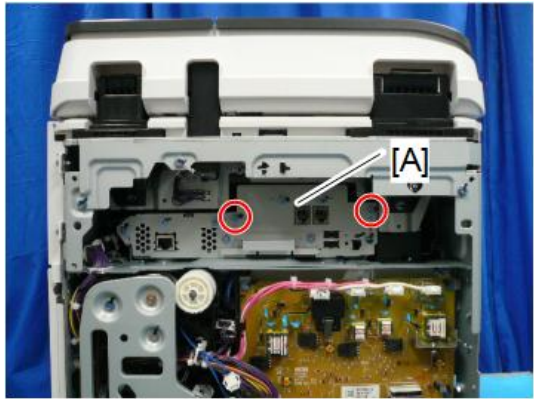

 x2

d3b3k1002

**8. Assemble the machine.**

**9. Plug in the machine and turn ON the main power.**

If a message states that the SRAM has been formatted due to a problem with SRAM, turn OFF then ON the main power again to clear the message. Enter the "User Tools" mode and set date and time.

**10. Do SP3102-000 in the fax SP mode and enter the serial number for the fax unit.**

**11. Enter the correct country code with SP2103-001 (NCU Country/ Area Code Setting).**

**12. Exit the SP mode, and turn OFF then ON the main power.**

## 1.2 FAX UNIT OPTIONS

### 1.2.1 FAX CONNECTION UNIT TYPE M15

#### *Overview of Fax Connection Unit*

This unit allows a machine without the fax unit installed (“Client-side Machine”) to send and receive faxes via a machine with the fax unit installed (“Remote Machine”).

#### **Requirements:**

- Up to six machines can be registered as the Client-side Machines.
- Machines that have the fax unit installed cannot be used as the Client-side Machine.
- Only one machine can be registered as the Remote Machine.
- Firmware for this unit: “aics” (software number: D3A7759)
- Remote Fax transmissions are possible on a G3 line.
- The remote fax function does not support User Code Authentication. Disable the User Code Authentication on the Remote machine.
- Use this function to check the contents of a file that is stored in memory and not yet sent. Also, use this function to cancel a transmission from the Client-side Machine.

#### **Order of Fax Connection Unit installation procedure:**

1. Install the Fax Connection Unit in the Remote Machine (fax unit installed).
2. Install the Fax Connection Unit in the Client-side Machine (no fax unit installed).
3. Register the Client-side Machine in the Remote Machine.

#### **★ Important**

- **Do not register the Remote Machine before the Client-side Machine is registered in the Remote Machine. Otherwise, registering the Remote Machine fails.**
4. Register the Remote Machine in the Client-side Machine.

## Installing the application in the Remote Machine and Client-side Machine

1. Remove the T-shaped Cover.
2. Remove the SD card slot cover [A]

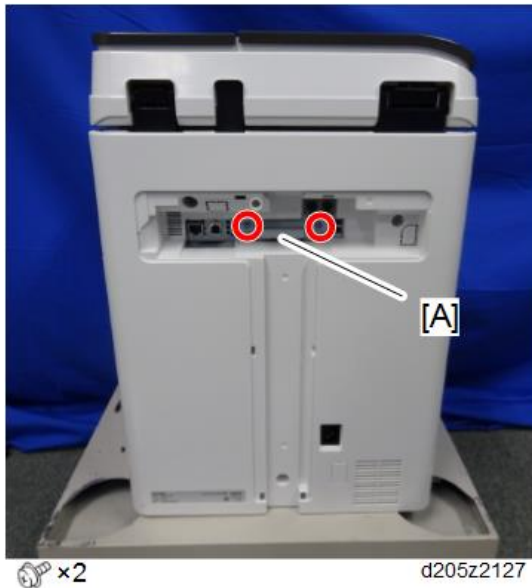

3. Insert the SD card (Fax Connection Unit Type M15) in SD slot 1 [A] if SD slot 1 is vacant. If slot 1 is not vacant, follow “Moving a Fax Communication application into an SD card in SD slot 1” shown below.

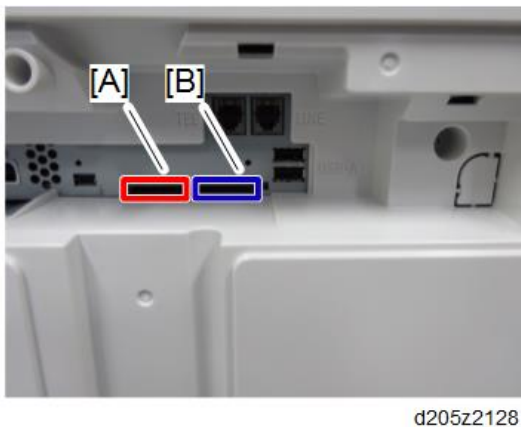

4. Plug in, and then turn on the machine.
5. Press [Firmware Version] in the [Administrator Tools].  
[User Tools/Counter] > [System Settings] > [Administrator Tools]
6. Check whether the aics version is displayed.

## Fax Unit Options

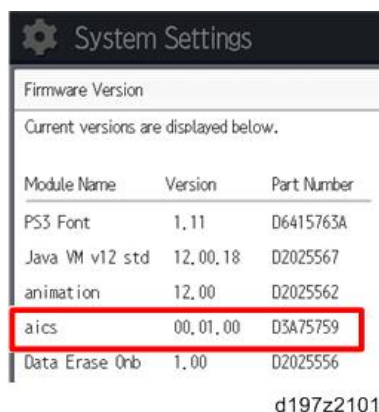

System Settings		
Firmware Version		
Current versions are displayed below.		
Module Name	Version	Part Number
PSS Font	1.11	D6415763A
Java VM v12 std	12.00.18	D2025567
animation	12.00	D2025562
aics	00.01.00	D3A75759
Data Erase Onb	1.00	D2025556

d197z2101

### Moving a Fax Communication application into an SD card in SD slot 1

1. Insert the SD card (Fax Connection Unit Type M15) SD slot 2 (lower) with its label face towards the front of the machine. Then push it slowly into SD slot 2 (lower) until you hear a click.
2. Plug in, and then turn on the machine.
3. Move the Fax Connection Unit Type M15 application from the SD card in SD slot 2 (lower) to the SD card in SD slot 1 (upper) with SP5-873-001.
4. Turn off the machine.
5. Remove the SD card from SD slot 2 (lower), and then keep it in a safe place (see “SD Card Appli Move” in the field service manual for the mainframe).
6. Attach the SD-card slot cover, and then turn on the machine 🖱️
7. Turn on the machine.
8. Press [Firmware Version] in the [Administrator Tools].  
[User Tools/Counter] > [System Settings] > [Administrator Tools]
9. Check whether the aics version is displayed.

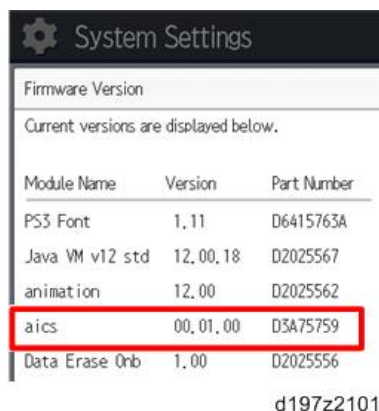

System Settings		
Firmware Version		
Current versions are displayed below.		
Module Name	Version	Part Number
PSS Font	1.11	D6415763A
Java VM v12 std	12.00.18	D2025567
animation	12.00	D2025562
aics	00.01.00	D3A75759
Data Erase Onb	1.00	D2025556

d197z2101

## Registering the Client-side Machine(s)

### ★ Important

- Do not register the Remote Machine in the Client-side machine before the Client-side Machine is registered in the Remote Machine. Otherwise, registering the Remote Machine fails.

#### On the Remote Machine:

- Press [User Tools/Counter] on the operation panel.
- Press [System Settings].
- Press [Administrator Tools].
- Press [Program/Change/Delete Remote Machine].
- Press one of the machine registration lines, and then enter the IP address or host name of one of the Client-side Machines.
- Press [Connection Test] to check the connection with the client-side machine.

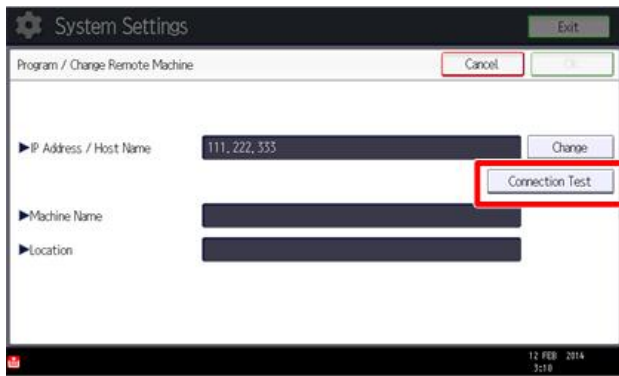

d197z2104

If an error message is displayed, check the network connection with the client-side machine and make sure that the IP address of the client-side machine is correct.

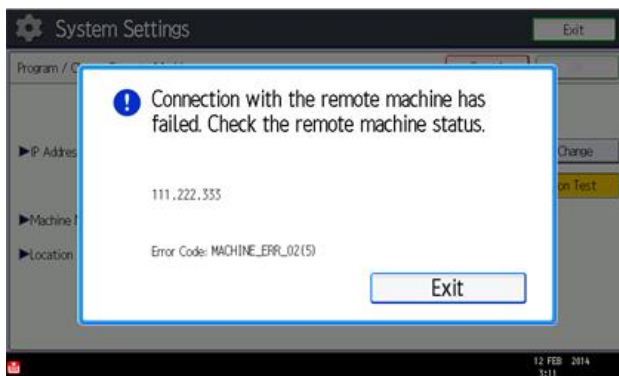

d197z2105

- Press [OK] after "Connection Test" has been successfully done.



## Fax Unit Options

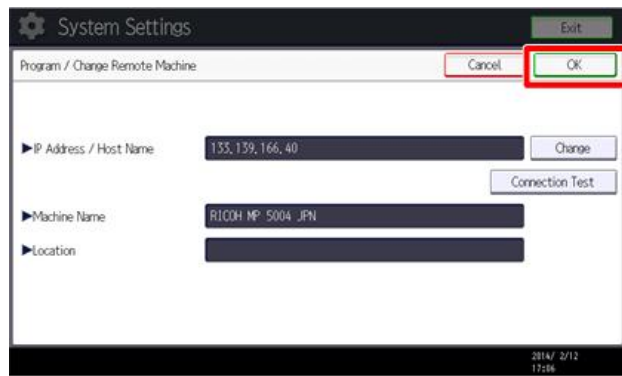

d197z2106

8. Press [User Tools/Counter] on the operation panel to terminate the System Settings.

### Registering the Remote Machine

#### ★ Important

- First register the Client-side Machine in the Remote Machine before proceeding this procedure. Otherwise, registering the Remote Machine fails.

#### ↓ Note

- Only one machine can be registered as the Remote Machine.

#### On the Client-side Machine(s):

1. Press [User Tools/Counter] on the operation panel.
2. Press [System Settings].
3. Press [Administrator Tools].
4. Press [Program/Change/Delete Remote Machine].
5. Enter the IP address or host name of the Remote Machine.
6. Press one of the machine registration lines, and then enter the IP address or host name of the Remote Machine.

#### ↓ Note

- Only one machine can be registered as the Remote Machine.

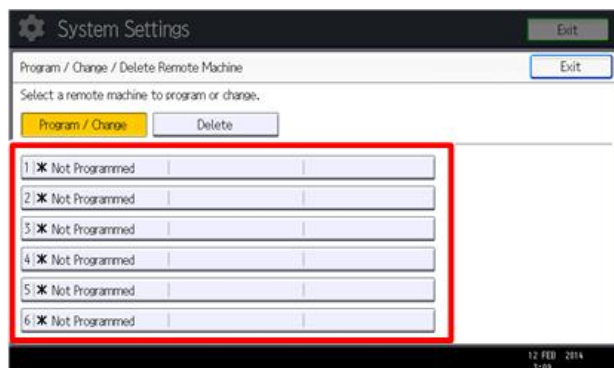

d197z2103

7. Press [Connection Test] to check the connection with the remote machine.

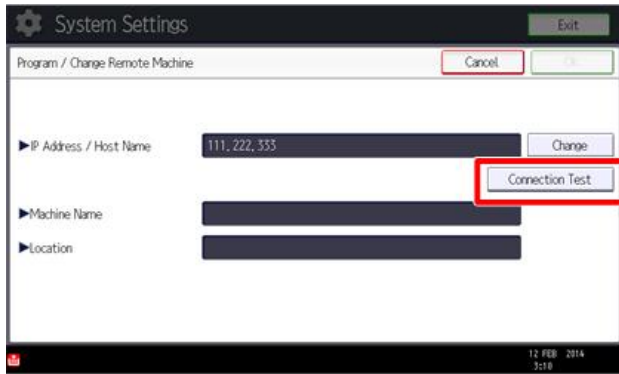

d197z2104

If an error message is displayed, check the network connection with the remote machine and make sure that the IP address of the remote machine is correct.

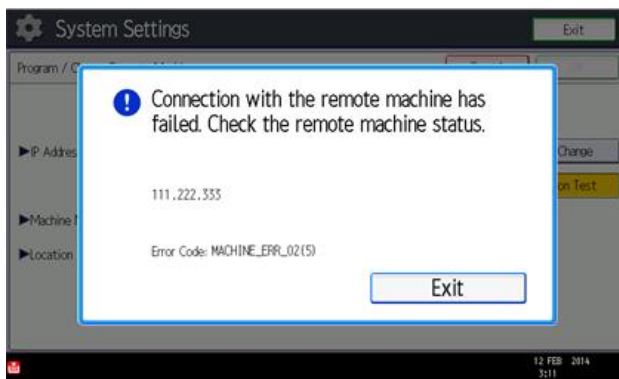

d197z2105

8. Press [OK] after “Connection Test” has been successfully done.

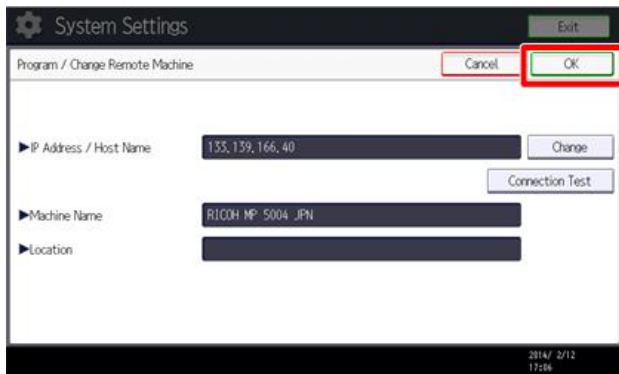

d197z2106

9. Press [User Tools/Counter] key on the operation panel to terminate the System Settings.

## Configuring the Remote Reception Settings

Do the following procedure to enable the Client-side Machine(s) to receive faxes via the Remote Machine. You can forward or route received documents per line or special sender.

### Note

- By performing procedures described above (Installing the application in the Remote Machine and Client-side Machine, Registering the Client-side Machine(s), Registering the Remote Machine), the Client-side Machines can **send** faxes via the Remote Machine. The procedures shown below are necessary to enable the Client-side Machines to **receive** faxes

**On the Remote Machine:**

#### 1) If you use "Remote Reception Setting per Line"

- Press [Facsimile Features].
- Press [Remote Reception Setting per Line] in [Reception Settings].
- Enter an IP address or a host name of the client-side machine to connect.
- Press [Set], and [Exit] to exit from the setting.

#### 2) If you use "Remote Reception per Sender"

- Press [Facsimile Features].
- Press [Program Special Sender] in [Reception Settings].
- Select the Special Sender.

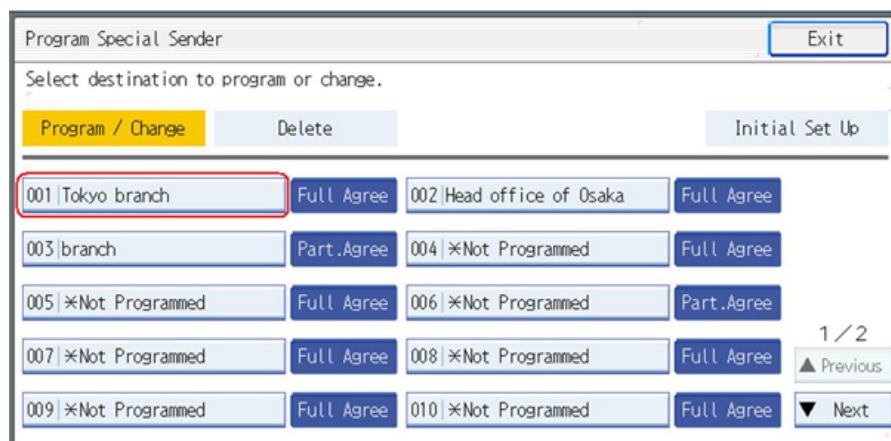

d1661001

- Press [Remote Reception Setting per Sender].

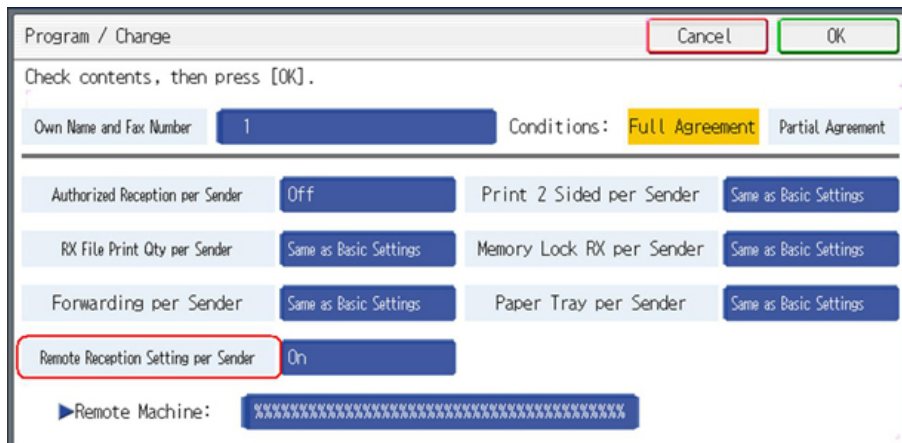

d1661002

**5. Press [On] and [Remote Machine].**

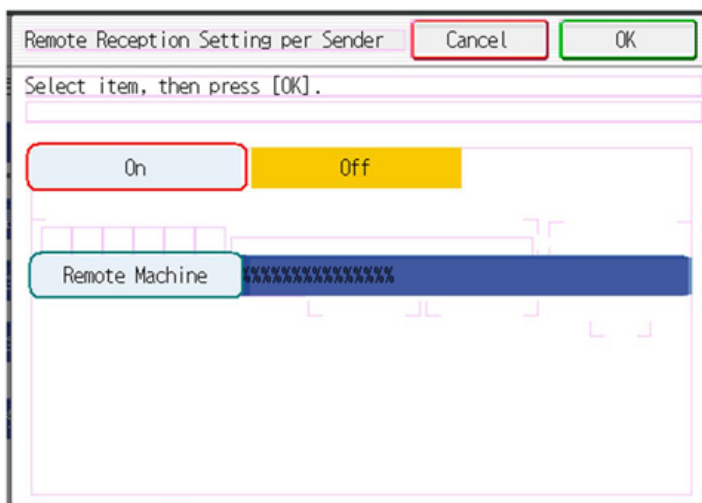

d1661003

- 6. Enter an IP address or a host name of the client-side machine to connect.**
- 7. Press [OK] to exit from the setting.**

### **Remote Fax Icon Addition for Remote Machine**

The icon of the fax communication is supposed to appear automatically on the home screen of the Client-side Machine(s) after installation of the Fax Communication. If the icon of the fax communication does not appear, add the icon manually. This procedure allows the remote fax icon to appear on the home screen of the operation panel.

**On both the Remote Machine and the Client-side Machines:**

1. Press [User Tools].
2. Press [Edit Home].

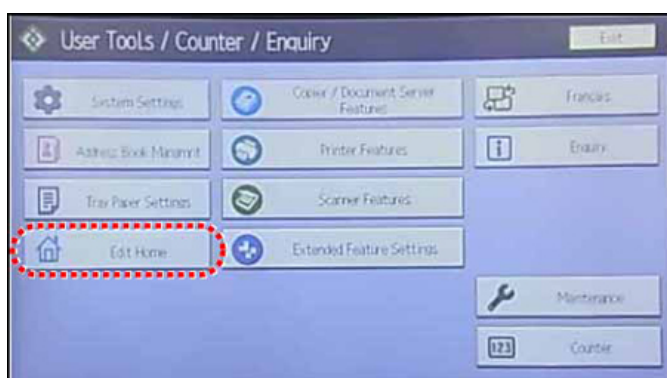

d1440144

3. Press [Add Icon].

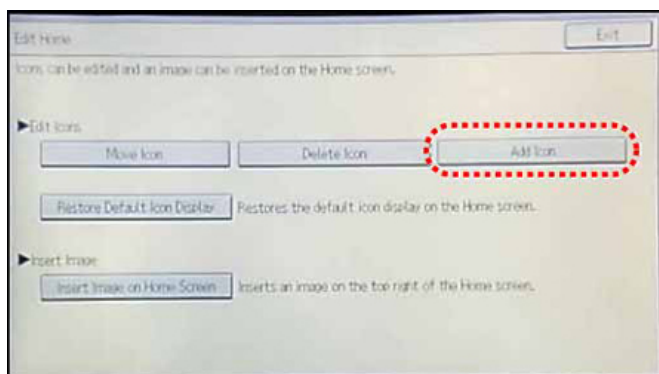

d1440145

4. Press [Remote Fax].

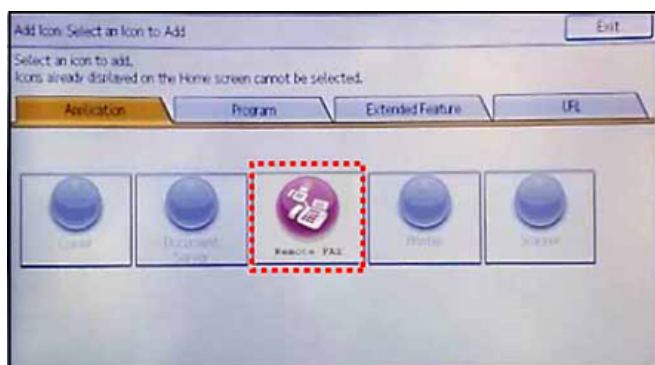

d1440146a

5. Press a [Blank] to set a location for the remote fax icon.

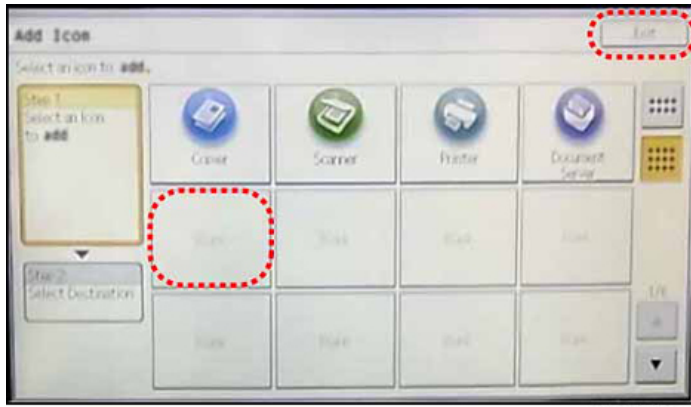

d1440147

6. Press [Exit] to exit from the set-up procedure.

FAX OPTION  
TYPE M15  
(D3B3)

---

## 2. REPLACEMENT AND ADJUSTMENT

### 2.1 FCU

#### 2.1.1 SRAM DATA TRANSFER PROCEDURE

When you replace the FCU board, transfer the SRAM data from the old FCU board to the new FCU board. Do the following procedure to back up the SRAM data.

**Note**

- The following data can be transferred: TTI, RTI, CSI, Fax bit switch settings, RAM address settings, NCU parameter settings.

**1. Remove the T-shaped cover [A].**



**2. Remove the screws of the rear cover [A].**

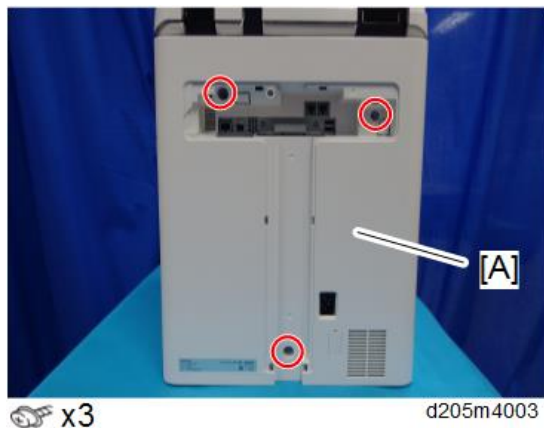

**3. Open the right cover.**

**4. Remove the rear cover [A].**



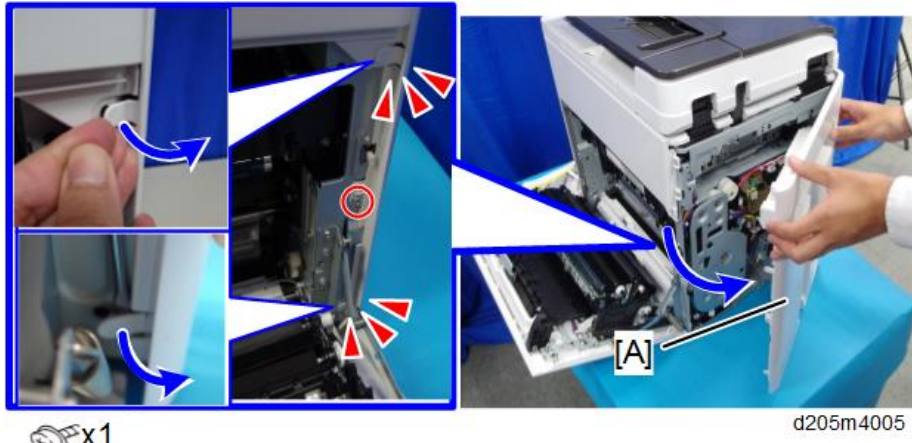

**Note**

- Be careful not to damage the tabs at the rear of the left cover when removing or installing the rear cover.

**5. Remove the FCU with bracket.**

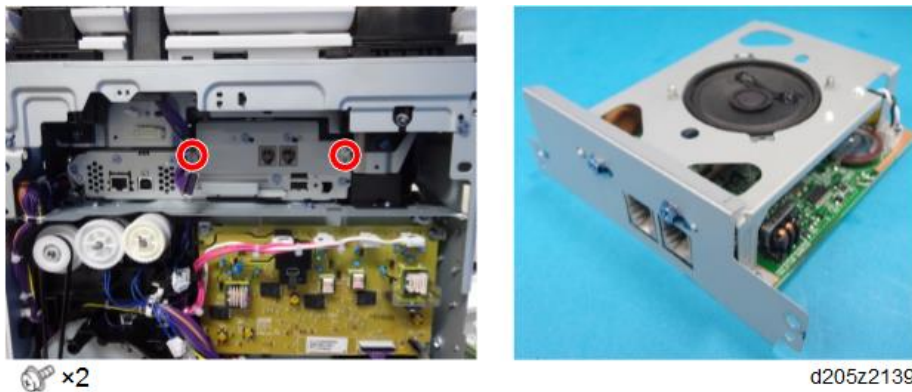

**6. Separate the FCU board [A], FCU bracket [B], and the speaker [C]. Then replace the FCU board with a new one.**

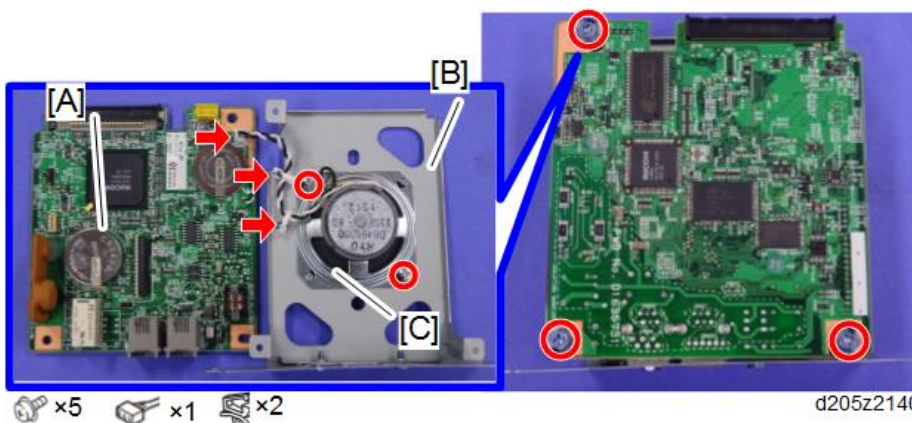

**7. Connect the flat flexible cable (a service part) to the old FCU board.**

**Note**

- When connecting the flat flexible cable, insert the connector straight.

**8. Attach the jumper pin to the new FCU board, and connect the flat flexible cable to the connector [A] of the old FCU board.**



9. Turn on the main power switch.
10. SRAM data transmission starts. When the transmission is completed, you will hear a beeper sound.

 Note

- The beeper sound is the same volume as the speaker sound.
  - The beeper sounds even if the speaker sound is turned off.
  - If the beeper does not sound, turn the main power switch on and off repeatedly and do the transmission procedure 2 or 3 times.
  - If the beeper does not sound after turning the main switch on and off 3 times, you need to input the settings stored in SRAM memory manually.
11. When “Ready” appears on the operation panel display, turn off the main power switch, and then disconnect the flat flexible cable from the old FCU board.
  12. Disconnect the flat flexible cable from the new FCU board.
  13. Reassemble the machine.

## 3. TROUBLESHOOTING

### 3.1 FAX CONNECTION UNIT ERROR CODES

#### 3.1.1 FAX CONNECTION UNIT ERROR CODE LIST

##### ***MACHINE\_ERR\_01***

Error Code	Suggested Cause	Action
01(1)	IPv4/IPv6 not enabled	Enable IPv4 and IPv6
01(3)	"Cancel" is pressed by user.	-
01(4)	A false connection ID is being used.	Check that the network is established.
01(5)	Network disconnected because of no response within a specified time.	
01(14)	<ul style="list-style-type: none"> <li>▪ The machine either of destination or of local is entering SP or Initial setting.</li> <li>▪ An established connection exists.</li> </ul>	<ul style="list-style-type: none"> <li>▪ Exit SP or initial setting.</li> <li>▪ Wait until the connection has finished.</li> </ul>

##### ***MACHINE\_ERR\_02***

Error Code	Suggested Cause	Action
02(5)	<ul style="list-style-type: none"> <li>▪ Wrong IP address/hostname is used</li> <li>▪ The machine at destination power off</li> <li>▪ LAN cable is disconnected</li> <li>▪ Network is rebooting.</li> </ul>	<ul style="list-style-type: none"> <li>▪ Enter the correct IP address/Host name</li> <li>▪ Turn on the main power.</li> <li>▪ Connect the LAN cable</li> <li>▪ Wait until the rebooting has finished.</li> </ul>

***MACHINE\_ERR\_03***

Error Code	Suggested Cause	Action	
03	<ul style="list-style-type: none"> <li>▪ No user authentication applies for fax application (i.e. Basic/Windows/LDAP/Custom Auth.)</li> <li>▪ Settings other than user authentication are applied to the fax application.</li> </ul>	Configure the user authentication setting for client-side and Remote Machine as the following table.	
		Client-side Machine	Remote Machine
		OFF	OFF
		ON	OFF
		ON	ON

***MACHINE\_ERR\_04***

Error Code	Suggested Cause	Action	
04	Although the same user registered to the Remote Machine and Client-side Machine, the user name and password for login are unmatched between the two locations.	<ul style="list-style-type: none"> <li>▪ Register the same user to both the Remote Machine and Client-side Machine.</li> <li>▪ Be sure to match the username and password for login between the two locations.</li> </ul>	

***MACHINE\_ERR\_05***

Error Code	Suggested Cause	Action
05	An unauthorized user connects to the fax connection.	Authorize the user to use fax connection.

***MACHINE\_ERR\_06***

Error Code	Suggested Cause	Action
06	Timeout error on the node authentication	Adjust the value of SP5-741-001 to prolong the timeout for node authentication.

***MACHINE\_ERR\_07***

Error Code	Suggested Cause	Action
07	Multiple destinations are set in the Client-side Machine.	In the Client-side Machine, execute SP5-801-021 to clear AICS memory

***MACHINE\_ERR\_08***

Error Code	Suggested Cause	Action
08(1)	<ul style="list-style-type: none"> <li>▪ A Client-side Machine connects to other Client-side Machine.</li> <li>▪ The Client-side Machine not registered in the Remote Machine as destinations.</li> </ul>	<ul style="list-style-type: none"> <li>▪ Connect to the Remote Machine.</li> <li>▪ Register the Client-side Machine to the Remote Machine as a destination.</li> </ul>
08(2)	<ul style="list-style-type: none"> <li>▪ A Remote Machine connects to other Remote Machine.</li> <li>▪ Wrong Remote Machine registered in the Client-side Machine.</li> </ul>	<ul style="list-style-type: none"> <li>▪ Connect to the Client-side Machine.</li> <li>▪ Check what Remote Machine registered in the Client-side Machine.</li> </ul>

## 3.2 ERROR CODES

If an error code occurs, retry the communication. If the same problem occurs, try to fix the problem as suggested below. Note that some error codes appear only in the error code display and on the service report.

Code	Meaning	Suggested Cause/Action
0-00	DIS/NSF not detected within 40 s of Start being pressed	<ul style="list-style-type: none"> <li>▪ Check the line connection.</li> <li>▪ The machine at the other end may be incompatible.</li> <li>▪ Replace the FCU.</li> <li>▪ Check for DIS/NSF with an oscilloscope.</li> <li>▪ If the rx signal is weak, there may be a bad line.</li> </ul>
0-01	DCN received unexpectedly	<ul style="list-style-type: none"> <li>▪ The other party is out of paper or has a jammed printer.</li> <li>▪ The other party pressed Stop during communication.</li> </ul>
0-03	Incompatible modem at the other end	The other terminal is incompatible.
0-04	CFR or FTT not received after modem training	<ul style="list-style-type: none"> <li>▪ Check the line connection.</li> <li>▪ Try changing the tx level and/or cable equalizer settings.</li> <li>▪ Replace the FCU.</li> <li>▪ The other terminal may be faulty; try sending to another machine.</li> <li>▪ If the rx signal is weak or defective, there may be a bad line.</li> </ul> <p><b>Cross reference</b></p> <p>Tx level - NCU Parameter 01 (PSTN) Cable equalizer - G3 Switch 07 (PSTN) Dedicated Tx parameters in Service Program Mode</p>

Error Codes

Code	Meaning	Suggested Cause/Action
0-05	Modem training fails even G3 shifts down to 2400 bps.	<ul style="list-style-type: none"> <li>▪ Check the line connection.</li> <li>▪ Try adjusting the tx level and/or cable equalizer.</li> <li>▪ Replace the FCU.</li> <li>▪ Check for line problems.</li> </ul> <p><b>Cross reference</b> See error code 0-04.</p>
0-06	The other terminal did not reply to DCS	<ul style="list-style-type: none"> <li>▪ Check the line connection.</li> <li>▪ Try adjusting the tx level and/or cable equalizer settings.</li> <li>▪ Replace the FCU.</li> <li>▪ The other end may be defective or incompatible; try sending to another machine.</li> <li>▪ Check for line problems.</li> </ul> <p><b>Cross reference</b> See error code 0-04.</p>
0-07	No post-message response from the other end after a page was sent	<ul style="list-style-type: none"> <li>▪ Check the line connection.</li> <li>▪ Replace the FCU.</li> <li>▪ The other end may have jammed or run out of paper.</li> <li>▪ The other end user may have disconnected the call.</li> <li>▪ Check for a bad line.</li> <li>▪ The other end may be defective; try sending to another machine.</li> </ul>

Code	Meaning	Suggested Cause/Action
0-08	The other end sent RTN or PIN after receiving a page, because there were too many errors	<ul style="list-style-type: none"> <li>▪ Check the line connection.</li> <li>▪ Replace the FCU.</li> <li>▪ The other end may have jammed, or run out of paper or memory space.</li> <li>▪ Try adjusting the tx level and/or cable equalizer settings.</li> <li>▪ The other end may have a defective modem/FCU; try sending to another machine.</li> <li>▪ Check for line problems and noise.</li> </ul> <p><b>Cross reference</b></p> <ul style="list-style-type: none"> <li>▪ Tx level - NCU Parameter 01 (PSTN)</li> <li>▪ Cable equalizer - G3 Switch 07 (PSTN)</li> <li>▪ Dedicated Tx parameters in Service Program Mode</li> </ul>
0-14	Non-standard post message response code received	<ul style="list-style-type: none"> <li>▪ Incompatible or defective remote terminal; try sending to another machine.</li> <li>▪ Noisy line: resend.</li> <li>▪ Try adjusting the tx level and/or cable equalizer settings.</li> <li>▪ Replace the FCU.</li> </ul> <p><b>Cross reference</b> See error code 0-08.</p>
0-15	The other terminal is not capable of specific functions.	<p>The other terminal is not capable of accepting the following functions, or the other terminal's memory is full.</p> <ul style="list-style-type: none"> <li>▪ Confidential rx</li> <li>▪ Transfer function</li> <li>▪ SEP/SUB/PWD/SID</li> </ul>



## Error Codes

Code	Meaning	Suggested Cause/Action
0-16	CFR or FTT not detected after modem training in confidential or transfer mode	<ul style="list-style-type: none"> <li>▪ Check the line connection.</li> <li>▪ Replace the FCU.</li> <li>▪ Try adjusting the tx level and/or cable equalizer settings.</li> <li>▪ The other end may have disconnected, or it may be defective; try calling another machine.</li> <li>▪ If the rx signal level is too low, there may be a line problem.</li> </ul> <p><b>Cross reference</b> See error code 0-08.</p>
0-17	Communication was interrupted by pressing the stop key	<ul style="list-style-type: none"> <li>▪ If the Stop key was not pressed and this error keeps occurring, replace the operation panel or the operation panel drive board.</li> </ul>
0-20	Facsimile data not received within 6 s of retraining	<ul style="list-style-type: none"> <li>▪ Check the line connection.</li> <li>▪ Replace the FCU.</li> <li>▪ Check for line problems.</li> <li>▪ Try calling another fax machine.</li> <li>▪ Try adjusting the reconstruction time for the first line and/or rx cable equalizer setting.</li> </ul> <p><b>Cross reference</b> Reconstruction time - G3 Switch 0A, bit 6 Rx cable equalizer - G3 Switch 07 (PSTN)</p>
0-21	EOL signal (end-of-line) from the other end not received within 5 s of the previous EOL signal	<ul style="list-style-type: none"> <li>▪ Check the connections between the FCU and line.</li> <li>▪ Check for line noise or other line problems.</li> <li>▪ Replace the FCU.</li> <li>▪ The remote machine may be defective or may have disconnected.</li> </ul> <p><b>Cross reference</b> Maximum interval between EOLs and between ECM frames - G3 Bit Switch 0A, bit 4</p>

Code	Meaning	Suggested Cause/Action
0-22	The signal from the other end was interrupted for more than the acceptable modem carrier drop time (default: 200 ms)	<ul style="list-style-type: none"> <li>▪ Check the line connection.</li> <li>▪ Replace the FCU.</li> <li>▪ Defective remote terminal.</li> <li>▪ Check for line noise or other line problems.</li> <li>▪ Try adjusting the acceptable modem carrier drop time.</li> </ul> <p><b>Cross reference</b> Acceptable modem carrier drop time - G3 Switch 0A, bits 0 and 1</p>
0-23	Too many errors during reception	<ul style="list-style-type: none"> <li>▪ Check the line connection.</li> <li>▪ Replace the FCU.</li> <li>▪ Defective remote terminal</li> <li>▪ Check for line noise or other line problems.</li> <li>▪ Try asking the other end to adjust their tx level.</li> <li>▪ Try adjusting the rx cable equalizer setting and/or rx error criteria.</li> </ul> <p><b>Cross reference</b> Rx cable equalizer - G3 Switch 07 (PSTN) Rx error criteria - Communication Switch 02, bits 0 and 1</p>
0-30	The other terminal did not reply to NSS(A) in AI short protocol mode	<ul style="list-style-type: none"> <li>▪ Check the line connection.</li> <li>▪ Try adjusting the tx level and/or cable equalizer settings.</li> <li>▪ The other terminal may not be compatible.</li> </ul> <p><b>Cross reference</b> Dedicated tx parameters - Section 4</p>
0-32	The other terminal sent a DCS, which contained functions that the receiving machine cannot handle.	<ul style="list-style-type: none"> <li>▪ Check the protocol dump list.</li> <li>▪ Ask the other party to contact the manufacturer.</li> </ul>
0-33	The data reception (not ECM) is not completed within 10 minutes.	<ul style="list-style-type: none"> <li>▪ Check the line connection.</li> <li>▪ The other terminal may have a defective modem/FCU.</li> </ul>
0-52	Polarity changed during communication	<ul style="list-style-type: none"> <li>▪ Check the line connection.</li> </ul> <p>Retry communication.</p>

## Error Codes

Code	Meaning	Suggested Cause/Action
0-55	FCU does not detect the SG3.	<ul style="list-style-type: none"> <li>▪ FCU firmware or board defective.</li> <li>▪ SG3 firmware or board defective.</li> </ul>
0-56	The stored message data exceeds the capacity of the mailbox in the SG3.	<ul style="list-style-type: none"> <li>▪ SG3 firmware or board defective.</li> </ul>
0-70	The communication mode specified in CM/JM was not available (V.8 calling and called terminal)	<ul style="list-style-type: none"> <li>▪ The other terminal did not have a compatible communication mode (e.g., the other terminal was a V.34 data modem and not a fax modem.)</li> <li>▪ A polling tx file was not ready at the other terminal when polling rx was initiated from the calling terminal.</li> </ul>
0-74	The calling terminal fell back to T.30 mode, because it could not detect ANSam after sending CI.	<ul style="list-style-type: none"> <li>▪ The calling terminal could not detect ANSam due to noise, etc.</li> <li>▪ ANSam was too short to detect.</li> <li>▪ Check the line connection and condition.</li> <li>▪ Try making a call to another V.8/V.34 fax.</li> </ul>
0-75	The called terminal fell back to T.30 mode, because it could not detect a CM in response to ANSam (ANSam timeout).	<ul style="list-style-type: none"> <li>▪ The terminal could not detect ANSam.</li> <li>▪ Check the line connection and condition.</li> <li>▪ Try receiving a call from another V.8/V.34 fax.</li> </ul>
0-76	The calling terminal fell back to T.30 mode, because it could not detect a JM in response to CM (CM timeout).	<ul style="list-style-type: none"> <li>▪ The called terminal could not detect a CM due to noise, etc.</li> <li>▪ Check the line connection and condition.</li> <li>▪ Try making a call to another V.8/V.34 fax.</li> </ul>
0-77	The called terminal fell back to T.30 mode, because it could not detect a CJ in response to JM (JM timeout).	<ul style="list-style-type: none"> <li>▪ The calling terminal could not detect a JM due to noise, etc.</li> <li>▪ A network that has narrow bandwidth cannot pass JM to the other end.</li> <li>▪ Check the line connection and condition.</li> <li>▪ Try receiving a call from another V.8/V.34 fax.</li> </ul>

Code	Meaning	Suggested Cause/Action
0-79	The called terminal detected CI while waiting for a V.21 signal.	<ul style="list-style-type: none"> <li>▪ Check for line noise or other line problems.</li> <li>▪ If this error occurs, the called terminal falls back to T.30 mode.</li> </ul>
0-80	The line was disconnected due to a timeout in V.34 phase 2 – line probing.	<ul style="list-style-type: none"> <li>▪ The guard timer expired while starting these phases. Serious noise, narrow bandwidth, or low signal level can cause these errors.</li> </ul> <p>If these errors happen at the transmitting terminal:</p> <ul style="list-style-type: none"> <li>▪ Try making a call at a later time.</li> <li>▪ Try using V.17 or a slower modem using dedicated tx parameters.</li> <li>▪ Try increasing the tx level.</li> </ul> <p>If these errors happen at the receiving terminal:</p> <ul style="list-style-type: none"> <li>▪ Try adjusting the tx cable equalizer setting.</li> <li>▪ Try adjusting the rx cable equalizer setting.</li> <li>▪ Try increasing the tx level.</li> <li>▪ Try using V.17 or a slower modem if the same error is frequent when receiving from multiple senders.</li> </ul>
0-81	The line was disconnected due to a timeout in V.34 phase 3 – equalizer training.	
0-82	The line was disconnected due to a timeout in the V.34 phase 4 – control channel start-up.	
0-83	The line was disconnected due to a timeout in the V.34 control channel restart sequence.	
0-84	The line was disconnected due to abnormal signaling in V.34 phase 4 – control channel start-up.	<ul style="list-style-type: none"> <li>▪ The signal did not stop within 10 s.</li> <li>▪ Turn off the machine, then turn it back on.</li> <li>▪ If the same error is frequent, replace the FCU.</li> </ul>
0-85	The line was disconnected due to abnormal signaling in V.34 control channel restart.	<ul style="list-style-type: none"> <li>▪ The signal did not stop within 10 s.</li> <li>▪ Turn off the machine, then turn it back on.</li> <li>▪ If the same error is frequent, replace the FCU.</li> </ul>
0-86	The line was disconnected because the other terminal requested a data rate using MPh that was not available in the currently selected symbol rate.	<ul style="list-style-type: none"> <li>▪ The other terminal was incompatible.</li> <li>▪ Ask the other party to contact the manufacturer.</li> </ul>

## Error Codes

Code	Meaning	Suggested Cause/Action
0-87	The control channel started after an unsuccessful primary channel.	<ul style="list-style-type: none"> <li>▪ The receiving terminal restarted the control channel because data reception in the primary channel was not successful.</li> <li>▪ This does not result in an error communication.</li> </ul>
0-88	The line was disconnected because PPR was transmitted/received 9 (default) times within the same ECM frame.	<ul style="list-style-type: none"> <li>▪ Try using a lower data rate at the start.</li> <li>▪ Try adjusting the cable equalizer setting.</li> </ul>
2-11	Only one V.21 connection flag was received	<ul style="list-style-type: none"> <li>▪ Replace the FCU.</li> </ul>
2-12	Modem clock irregularity	<ul style="list-style-type: none"> <li>▪ Replace the FCU.</li> </ul>
2-13	Modem initialization error	<ul style="list-style-type: none"> <li>▪ Turn off the machine, then turn it back on.</li> <li>▪ Update the modem ROM.</li> <li>▪ Replace the FCU.</li> </ul>
2-22	Counter overflow error of JBIG chip	<ul style="list-style-type: none"> <li>▪ If this error occurs frequently, change the settings for resolution, paper size and compression type.</li> </ul>
2-23	JBIG compression or reconstruction error	<ul style="list-style-type: none"> <li>▪ Turn off the machine, then turn it back on.</li> </ul>
2-24	JBIG ASIC error	<ul style="list-style-type: none"> <li>▪ Turn off the machine, then turn it back on.</li> </ul>
2-25	JBIG data reconstruction error (BIH error)	<ul style="list-style-type: none"> <li>▪ JBIG data error</li> <li>▪ Check the sender's JBIG function.</li> <li>▪ Update the MBU ROM.</li> </ul>
2-26	JBIG data reconstruction error (Float marker error)	
2-27	JBIG data reconstruction error (End marker error)	
2-28	JBIG data reconstruction error (Timeout)	

Code	Meaning	Suggested Cause/Action
2-29	JBIG trailing edge maker error	<ul style="list-style-type: none"> <li>▪ FCU defective</li> <li>▪ Check the destination device.</li> </ul>
2-50	The machine resets itself for a fatal FCU system error	<ul style="list-style-type: none"> <li>▪ If this is frequent, update the ROM, or replace the FCU.</li> </ul>
2-51	The machine resets itself because of a fatal communication error	<ul style="list-style-type: none"> <li>▪ If this is frequent, update the ROM, or replace the FCU.</li> </ul>
2-53	Snd msg() in the manual task is an error because the mailbox for the operation task is full.	<ul style="list-style-type: none"> <li>▪ The user did the same operation many times, and this gave too much load to the machine.</li> </ul>
4-01	Line current was cut	<ul style="list-style-type: none"> <li>▪ Check the line connector.</li> <li>▪ Check for line problems.</li> <li>▪ Replace the FCU.</li> </ul>
4-10	Communication failed because of an ID Code mismatch (Closed Network) or Tel. No./CSI mismatch (Protection against Wrong Connections)	<ul style="list-style-type: none"> <li>▪ Get the ID Codes the same and/or the CSIs programmed correctly, then resend.</li> <li>▪ The machine at the other end may be defective.</li> </ul>
5-00	Data reconstruction not possible	<ul style="list-style-type: none"> <li>▪ Replace the FCU</li> </ul>
5-10	DCR timer expired	<ul style="list-style-type: none"> <li>▪ Replace the FCU.</li> </ul>
5-20	Storage impossible because of a lack of memory	<ul style="list-style-type: none"> <li>▪ Temporary memory shortage.</li> <li>▪ Test the SAF memory.</li> </ul>
5-21	Memory overflow	
5-23	Print data error when printing a substitute rx or confidential rx message	<ul style="list-style-type: none"> <li>▪ Test the SAF memory.</li> <li>▪ Ask the other end to resend the message.</li> </ul>

## Error Codes

Code	Meaning	Suggested Cause/Action
5-25	SAF file access error	<ul style="list-style-type: none"> <li>▪ Replace an SD card or HDD.</li> <li>▪ Replace the FCU.</li> </ul>
6-00	G3 ECM - T1 time out during reception of facsimile data	<ul style="list-style-type: none"> <li>▪ Try adjusting the rx cable equalizer.</li> <li>▪ Replace the FCU.</li> </ul>
6-01	G3 ECM - no V.21 signal was received	
6-02	G3 ECM - EOR was received	
6-04	G3 ECM - RTC not detected	<ul style="list-style-type: none"> <li>▪ Check the line connection.</li> <li>▪ Check for a bad line or defective remote terminal.</li> <li>▪ Replace the FCU.</li> </ul>
6-05	G3 ECM - facsimile data frame not received within 18 s of CFR, but there was no line fail	<ul style="list-style-type: none"> <li>▪ Check the line connection.</li> <li>▪ Check for a bad line or defective remote terminal.</li> <li>▪ Replace the FCU.</li> <li>▪ Try adjusting the rx cable equalizer</li> </ul> <p><b>Cross reference</b></p> <ul style="list-style-type: none"> <li>▪ Rx cable equalizer - G3 Switch 07 (PSTN)</li> </ul>
6-06	G3 ECM - coding/decoding error	<ul style="list-style-type: none"> <li>▪ Defective FCU.</li> <li>▪ The other terminal may be defective.</li> </ul>
6-08	G3 ECM - PIP/PIN received in reply to PPS.NULL	<ul style="list-style-type: none"> <li>▪ The other end pressed Stop during communication.</li> <li>▪ The other terminal may be defective.</li> </ul>
6-09	G3 ECM - ERR received	<ul style="list-style-type: none"> <li>▪ Check for a noisy line.</li> <li>▪ Adjust the tx levels of the communicating machines.</li> <li>▪ See code 6-05.</li> </ul>

Code	Meaning	Suggested Cause/Action
6-10	G3 ECM - error frames still received at the other end after all communication attempts at 2400 bps	<ul style="list-style-type: none"> <li>▪ Check for line noise.</li> <li>▪ Adjust the tx level (use NCU parameter 01 or the dedicated tx parameter for that address).</li> <li>▪ Check the line connection.</li> <li>▪ Defective remote terminal.</li> </ul>
6-21	V.21 flag detected during high speed modem communication	<ul style="list-style-type: none"> <li>▪ The other terminal may be defective or incompatible.</li> </ul>
6-22	The machine resets the sequence because of an abnormal handshake in the V.34 control channel	<ul style="list-style-type: none"> <li>▪ Check for line noise.</li> <li>▪ If the same error occurs frequently, replace the FCU.</li> <li>▪ Defective remote terminal.</li> </ul>
6-99	V.21 signal not stopped within 6 s	<ul style="list-style-type: none"> <li>▪ Replace the FCU.</li> </ul>
13-17	SIP user name registration error	<ul style="list-style-type: none"> <li>▪ Double registration of the SIP user name.</li> <li>▪ Capacity for user-name registration in the SIP server is not sufficient.</li> </ul>
13-18	SIP server access error	<ul style="list-style-type: none"> <li>▪ Incorrect initial setting for the SIP server.</li> <li>▪ Defective SIP server.</li> </ul>
13-24	SIP authentication error	<ul style="list-style-type: none"> <li>▪ Registered password in the device does not match the password in the SIP server.</li> </ul>
13-25	Network I/F setting error	<ul style="list-style-type: none"> <li>▪ IPV4 is not active in the active protocol setting.</li> <li>▪ IP address of the device is not registered.</li> </ul>
13-26	Network I/F setting error at power on	<ul style="list-style-type: none"> <li>▪ Active protocol setting does not match the I/F setting for SIP server.</li> <li>▪ IP address of the device is not registered.</li> </ul>
13-27	IP address setting error	<ul style="list-style-type: none"> <li>▪ IP address of the device is not registered.</li> </ul>
14-00	SMTP Send Error	<ul style="list-style-type: none"> <li>▪ Error occurred during sending to the SMTP server. Occurs for any error other than 14-01 to 16. For example, the mail address of the system administrator is not registered.</li> </ul>



## Error Codes

Code	Meaning	Suggested Cause/Action
14-01	SMTP Connection Failed	<ul style="list-style-type: none"> <li>▪ Failed to connect to the SMTP server (timeout) because the server could not be found.</li> <li>▪ The PC is not ready to transfer files.</li> <li>▪ SMTP server not functioning correctly.</li> <li>▪ The DNS IP address is not registered.</li> <li>▪ Network not operating correctly.</li> <li>▪ Destination folder selection not correct.</li> </ul>
14-02	No Service by SMTP Service (421)	<ul style="list-style-type: none"> <li>▪ SMTP server operating incorrectly, or the destination for direct SMTP sending is not correct.</li> <li>▪ Contact the system administrator and check that the SMTP server has the correct settings and operates correctly.</li> <li>▪ Contact the system administrator for direct SMTP sending and check the sending destination.</li> </ul>
14-03	Access to SMTP Server Denied (450)	<ul style="list-style-type: none"> <li>▪ Failed to access the SMTP server because the access is denied.</li> <li>▪ SMTP server operating incorrectly. Contact the system administrator to determine if there is a problem with the SMTP server and to check that the SMTP server settings are correct.</li> <li>▪ Folder send destination is incorrect. Contact the system administrator to determine that the SMTP server settings and path to the server are correct.</li> <li>▪ Device settings incorrect. Confirm that the user name and password settings are correct.</li> <li>▪ Direct SMTP destination incorrect. Contact the system administrator to determine if there is a problem at the destination at that the settings at the destination are correct.</li> </ul>
14-04	Access to SMTP Server Denied (550)	<ul style="list-style-type: none"> <li>▪ SMTP server operating incorrectly</li> <li>▪ Direct SMTP sending not operating correctly</li> </ul>

Code	Meaning	Suggested Cause/Action
14-05	SMTP Server HDD Full (452)	<ul style="list-style-type: none"> <li>▪ Failed to access the SMTP server because the HDD on the server is full.</li> <li>▪ Insufficient free space on the HDD of the SMTP server. Contact the system administrator and check the amount of space remaining on the SMTP server HDD.</li> <li>▪ Insufficient free space on the HDD where the destination folder is located. Contact the system administrator and check the amount of space remaining on the HDD where the target folder is located.</li> <li>▪ Insufficient free space on the HDD at the target destination for SMTP direct sending. Contact the system administrator and check the amount of space remaining on the target HDD.</li> </ul>
14-06	User Not Found on SMTP Server (551)	<ul style="list-style-type: none"> <li>▪ The designated user does not exist.</li> <li>▪ The designated user does not exist on the SMTP server.</li> <li>▪ The designated address is not for use with direct SMTP sending.</li> </ul>
14-07	Data Send to SMTP Server Failed (4XX)	<ul style="list-style-type: none"> <li>▪ Failed to access the SMTP server because the transmission failed.</li> <li>▪ PC not operating correctly.</li> <li>▪ SMTP server operating incorrectly</li> <li>▪ Network not operating correctly.</li> <li>▪ Destination folder setting incorrect.</li> <li>▪ Direct SMTP sending not operating correctly.</li> </ul>
14-08	Data Send to SMTP Server Failed (5XX)	<ul style="list-style-type: none"> <li>▪ Failed to access the SMTP server because the transmission failed.</li> <li>▪ SMTP server operating incorrectly</li> <li>▪ Destination folder setting incorrect.</li> <li>▪ Direct SMTP sending not operating correctly.</li> <li>▪ Software application error.</li> </ul>

## Error Codes

<b>Code</b>	<b>Meaning</b>	<b>Suggested Cause/Action</b>
14-09	Authorization Failed for Sending to SMTP Server	<ul style="list-style-type: none"> <li>▪ POP-Before-SMTP or SMTP authorization failed.</li> <li>▪ Incorrect setting for file transfer</li> </ul>
14-10	Addresses Exceeded	<ul style="list-style-type: none"> <li>▪ Number of broadcast addresses exceeded the limit for the SMTP server.</li> </ul>
14-11	Buffer Full	<ul style="list-style-type: none"> <li>▪ The send buffer is full so the transmission could not be completed. Buffer is full due to using Scan-to-Email while the buffer is being used send mail at the same time.</li> </ul>
14-12	Data Size Too Large	<ul style="list-style-type: none"> <li>▪ Transmission was cancelled because the detected size of the file was too large.</li> </ul>
14-13	Send Cancelled	<ul style="list-style-type: none"> <li>▪ Processing is interrupted because the user pressed Stop.</li> </ul>
14-14	Security Locked File Error	<ul style="list-style-type: none"> <li>▪ Update the software because of the defective software.</li> </ul>
14-15	Mail Data Error	<ul style="list-style-type: none"> <li>▪ The transmitting a mail is interrupted via DCS due to the incorrect data.</li> <li>▪ Update the software because of the defective software.</li> </ul>
14-16	Maximum Division Number Error	<ul style="list-style-type: none"> <li>▪ When a mail is divided for the mail transmission and the division number of a mail are more than the specified number, the mail transmission is interrupted.</li> <li>▪ Update the software because of the defective software.</li> </ul>
14-17	Incorrect Ticket	<ul style="list-style-type: none"> <li>▪ Update the software because of the defective software.</li> </ul>
14-18	Access to MCS File Error	<ul style="list-style-type: none"> <li>▪ The access to MCS file is denied due to the no permission of access.</li> <li>▪ Update the software because of the defective software.</li> </ul>

Code	Meaning	Suggested Cause/Action
14-20	SMTP Authentication Error	<ul style="list-style-type: none"> <li>Make sure that the administrator's e-mail address is the same as the SMTP authentication address or POP before SMTP address.</li> </ul>
14-21	Transmission error of S/MIME	<ul style="list-style-type: none"> <li>Register the correct user certificate and device certificate.</li> </ul>
14-30	MCS File Creation Failed	<p>Failed to create the MCS file because:</p> <ul style="list-style-type: none"> <li>The number of files created with other applications on the Document Server has exceeded the limit.</li> <li>HDD is full or not operating correctly.</li> <li>Software error.</li> </ul>
14-31	UFS File Creation Failed	<p>UFS file could not be created:</p> <ul style="list-style-type: none"> <li>Not enough space in UFS area to handle both Scan-to-Email and IFAX transmission.</li> <li>HDD full or not operating correctly.</li> <li>Software error.</li> </ul>
14-32	Cancelled the Mail Due to Error Detected by NFAX	<ul style="list-style-type: none"> <li>Error detected with NFAX and send was cancelled due to a software error.</li> </ul>
14-33	No Mail Address For the Machine	<ul style="list-style-type: none"> <li>Neither the mail address of the machine nor the mail address of the network administrator is registered.</li> </ul>
14-34	Address designated in the domain for SMTP sending does not exist	<ul style="list-style-type: none"> <li>Operational error in normal mail sending or direct SMTP sending.</li> <li>Check the address selected in the address book for SMTP sending.</li> <li>Check the domain selection.</li> </ul>
14-50	Mail Job Task Error	<p>Due to an FCU mail job task error, the send was cancelled:</p> <ul style="list-style-type: none"> <li>Address book was being edited during creation of the notification mail.</li> <li>Software error.</li> </ul>

## Error Codes

Code	Meaning	Suggested Cause/Action
14-51	UCS Destination Download Error	<p>Not even one return notification can be downloaded:</p> <ul style="list-style-type: none"> <li>▪ The address book was being edited.</li> <li>▪ The number for the specified destination does not exist (it was deleted or edited after the job was created).</li> </ul>
14-60	Send Cancel Failed	<ul style="list-style-type: none"> <li>▪ The cancel operation by the user failed to cancel the send operation.</li> </ul>
14-61	Notification Mail Send Failed for All Destinations	<ul style="list-style-type: none"> <li>▪ All addresses for return notification mail failed.</li> </ul>
14-62	Transmission Error due to the existence of zero line page	<ul style="list-style-type: none"> <li>▪ When the 0 line page exists in received pages with G3 communication, the transmission is interrupted.</li> </ul>
14-63	Fax Communication Unit: Transmission Error	<p>Check the followings.</p> <ul style="list-style-type: none"> <li>▪ Name of SMTP server</li> <li>▪ Port number of SMTP</li> <li>▪ DNS setting</li> <li>▪ Server name (FTP)</li> <li>▪ Path name (computer name and shared folder name at SMTP/ NCP)</li> <li>▪ Active protocol setting (Netware/ NCP)</li> <li>▪ NW flame type (NCP)</li> <li>▪ Log-on mode (NDS tree/ bindery)</li> </ul>
-		<p>Check the SMTP server.</p> <ul style="list-style-type: none"> <li>▪ Check if the SMTP server works normally and is connected to the network.</li> <li>▪ Check if the settings of the SMTP are correct.</li> </ul>
-		<p>Check the DNS server.</p> <ul style="list-style-type: none"> <li>▪ Check if the DNS server works normally and is connected to the network.</li> <li>▪ Check if the settings of the DNS server are correct.</li> </ul>

Code	Meaning	Suggested Cause/Action
-		<p>Check the network.</p> <ul style="list-style-type: none"> <li>▪ Check if the LAN works normally.</li> <li>▪ Check if the no firewall exists.</li> </ul>
-		<p>Check the destination folder for the data transfer.</p> <ul style="list-style-type: none"> <li>▪ Check if the destination folder works normally.</li> <li>▪ Check if the settings of the destination folder are correct.</li> </ul>
-		<p>Ask an administrator of the direct SMTP server in which the data is supposed to be transferred.</p> <ul style="list-style-type: none"> <li>▪ Check if the destination SMTP server works normally.</li> <li>▪ Check if the settings of the destination SMTP server are correct.</li> </ul>
15-01	POP3/IMAP4 Server Not Registered	<ul style="list-style-type: none"> <li>▪ At startup, the system detected that the IP address of the POP3/IMAP4 server has not been registered in the machine.</li> </ul>
15-02	POP3/IMAP4 Mail Account Information Not Registered	<ul style="list-style-type: none"> <li>▪ The POP3/IMAP4 mail account has not been registered.</li> </ul>
15-03	Mail Address Not Registered	<ul style="list-style-type: none"> <li>▪ The mail address has not been registered.</li> </ul>
15-10	DCS Mail Receive Error	<ul style="list-style-type: none"> <li>▪ Error other than 15-11 to 15-18.</li> </ul>
15-11	Connection Error	<p>The DNS or POP3/IMAP4 server could not be found:</p> <ul style="list-style-type: none"> <li>▪ The IP address for DNS or POP3/IMAP4 server is not stored in the machine.</li> <li>▪ The DNS IP address is not registered.</li> <li>▪ Network not operating correctly.</li> </ul>
15-12	Authorization Error	<p>POP3/IMAP4 send authorization failed:</p> <ul style="list-style-type: none"> <li>▪ Incorrect IFAX user name or password.</li> <li>▪ Access was attempted by another device, such as the PC.</li> <li>▪ POP3/IMAP4 settings incorrect.</li> </ul>

<b>Code</b>	<b>Meaning</b>	<b>Suggested Cause/Action</b>
15-13	Receive Buffer Full	<ul style="list-style-type: none"> <li>Occurs only during manual reception. Transmission cannot be received due to insufficient buffer space. The buffer is being used for mail send or Scan-to-Email.</li> </ul>
15-14	Mail Header Format Error	<ul style="list-style-type: none"> <li>The mail header is not standard format. For example, the Date line description is incorrect.</li> </ul>
15-15	Mail Divide Error	<ul style="list-style-type: none"> <li>The e-mail is not in standard format. There is no boundary between parts of the e-mail, including the header.</li> </ul>
15-16	Mail Size Receive Error	<ul style="list-style-type: none"> <li>The mail cannot be received because it is too large.</li> </ul>
15-17	Receive Timeout	<ul style="list-style-type: none"> <li>May occur during manual receiving only because the network is not operating correctly.</li> </ul>
15-18	Incomplete Mail Received	<ul style="list-style-type: none"> <li>Only one portion of the mail was received.</li> </ul>
15-31	Final Destination for Transfer Request Reception Format Error	<ul style="list-style-type: none"> <li>The format of the final destination for the transfer request was incorrect.</li> </ul>
15-39	Send/Delivery Destination Error	<p>The transmission cannot be delivered to the final destination:</p> <ul style="list-style-type: none"> <li>Destination file format is incorrect.</li> <li>Could not create the destination for the file transmission.</li> </ul>
15-41	SMTP Receive Error	<ul style="list-style-type: none"> <li>Reception rejected because the transaction exceeded the limit for the "Auth. E-mail RX" setting.</li> </ul>
15-42	Off Ramp Gateway Error	<ul style="list-style-type: none"> <li>The delivery destination address was specified with Off Ramp Gateway OFF.</li> </ul>
15-43	Address Format Error	<ul style="list-style-type: none"> <li>Format error in the address of the Off Ramp Gateway.</li> </ul>
15-44	Addresses Over	<ul style="list-style-type: none"> <li>The number of addresses for the Off Ramp Gateway exceeded the limit of 30.</li> </ul>

Code	Meaning	Suggested Cause/Action
15-61	Attachment File Format Error	<ul style="list-style-type: none"> <li>▪ The attached file is not TIFF format.</li> </ul>
15-62	TIFF File Compatibility Error	<p>Could not receive transmission due to:</p> <ul style="list-style-type: none"> <li>▪ Resolution error</li> <li>▪ Image of resolution greater than 200 dpi without extended memory.</li> <li>▪ Resolution is not supported.</li> <li>▪ Page size error</li> <li>▪ The page size was larger than A3.</li> <li>▪ Compression error</li> <li>▪ File was compressed with other than MH, MR, or MMR.</li> </ul>
15-63	TIFF Parameter Error	<p>The TIFF file sent as the attachment could not be received because the TIFF header is incorrect:</p> <ul style="list-style-type: none"> <li>▪ The TIFF file attachment is a type not supported.</li> <li>▪ The TIFF file attachment is corrupted.</li> <li>▪ Software error.</li> </ul>
15-64	TIFF Decompression Error	<p>The file received as an attachment caused the TIFF decompression error:</p> <ul style="list-style-type: none"> <li>▪ The TIFF format of the attachment is corrupted.</li> <li>▪ Software error.</li> </ul>
15-71	Not Binary Image Data	<ul style="list-style-type: none"> <li>▪ The file could not be received because the attachment was not binary image data.</li> </ul>
15-73	MDN Status Error	<ul style="list-style-type: none"> <li>▪ Could not find the Disposition line in the header of the Return Receipt, or there is a problem with the firmware.</li> </ul>
15-74	MDN Message ID Error	<ul style="list-style-type: none"> <li>▪ Could not find the Original Message ID line in the header of the Return Receipt, or there is a problem with the firmware.</li> </ul>



## Error Codes

Code	Meaning	Suggested Cause/Action
15-80	Mail Job Task Read Error	<ul style="list-style-type: none"> <li>Could not receive the transmission because the destination buffer is full and the destination could not be created (this error may occur when receiving a transfer request or a request for notification of reception).</li> </ul>
15-81	Repeated Destination Registration Error	<ul style="list-style-type: none"> <li>Could not repeat receive the transmission because the destination buffer is full and the destination could not be created (this error may occur when receiving a transfer request or a request for notification of reception).</li> </ul>
15-91	Send Registration Error	<p>Could not receive the file for transfer to the final destination:</p> <ul style="list-style-type: none"> <li>The format of the final destination or the transfer destination is incorrect.</li> <li>Destinations are full so the final and transfer destinations could not be created.</li> </ul>
15-92	Memory Overflow	<ul style="list-style-type: none"> <li>Transmission could not be received because memory overflowed during the transaction.</li> </ul>
15-93	Memory Access Error	<ul style="list-style-type: none"> <li>Transaction could not complete due to a malfunction of SAF memory.</li> </ul>
15-94	Incorrect ID Code	<ul style="list-style-type: none"> <li>The machine rejected an incoming e-mail for transfer request, because the ID code in the incoming e-mail did not match the ID code registered in the machine.</li> </ul>
15-95	Transfer Station Function	<ul style="list-style-type: none"> <li>The machine rejected an incoming e-mail for transfer because the transfer function was unavailable.</li> </ul>
22-00	Original length exceeded the maximum scan length	<ul style="list-style-type: none"> <li>Divide the original into more than one page.</li> <li>Check the resolution used for scanning. Lower the scan resolution if possible.</li> <li>Add optional page memory.</li> </ul>

Code	Meaning	Suggested Cause/Action
22-01	Memory overflow while receiving	<ul style="list-style-type: none"> <li>▪ Wait for the files in the queue to be sent.</li> <li>▪ Delete unnecessary files from memory.</li> <li>▪ Transfer the substitute reception files to an another fax machine, if the machine's printer is busy or out of order.</li> <li>▪ Add an optional SAF memory card or hard disk.</li> </ul>
22-02	Tx or rx job stalled due to line disconnection at the other end	<ul style="list-style-type: none"> <li>▪ The job started normally but did not finish normally; data may or may not have been received fully.</li> <li>▪ Restart the machine.</li> </ul>
22-04	The machine cannot store received data in the SAF	<ul style="list-style-type: none"> <li>▪ Update the ROM</li> <li>▪ Replace the FCU.</li> </ul>
22-05	No G3 parameter confirmation answer	<ul style="list-style-type: none"> <li>▪ Defective FCU board or firmware.</li> </ul>
23-00	Data read timeout during construction	<ul style="list-style-type: none"> <li>▪ Restart the machine.</li> <li>▪ Replace the FCU.</li> </ul>
25-00	The machine software resets itself after a fatal transmission error occurred	<ul style="list-style-type: none"> <li>▪ Update the ROM</li> <li>▪ Replace the FCU.</li> </ul>
F0-xx	V.34 modem error	<ul style="list-style-type: none"> <li>▪ Replace the FCU.</li> </ul>
F6-xx	SG3 modem error	<ul style="list-style-type: none"> <li>▪ Update the SG3 modem ROM.</li> <li>▪ Replace the SG3 board.</li> <li>▪ Check for line noise or other line problems.</li> <li>▪ Try communicating another V.8/V.34 fax.</li> </ul>

### 3.3 IFAX TROUBLESHOOTING

Use the following procedures to determine whether the machine or another part of the network is causing the problem.

Communication Route	Item	Action [Remarks]
General LAN	1. Connection with the LAN	<ul style="list-style-type: none"> <li>▪ Check that the LAN cable is connected to the machine.</li> <li>▪ Check that the LEDs on the hub are lit.</li> </ul>
	2. LAN activity	Check that other devices connected to the LAN can communicate through the LAN.
Between IFAX and PC	1. Network settings on the PC	<ul style="list-style-type: none"> <li>▪ Check the network settings on the PC. [Is the IP address registered in the TCP/IP properties in the network setup correct? Check the IP address with the administrator of the network.]</li> </ul>
	2. Check that PC can connect with the machine	<ul style="list-style-type: none"> <li>▪ Use the "ping" command on the PC to contact the machine. [At the MS-DOS prompt, type ping then the IP address of the machine, then press Enter.]</li> </ul>
	3. LAN settings in the machine	<ul style="list-style-type: none"> <li>▪ Check the LAN parameters</li> <li>▪ Check if there is an IP address conflict with other PCs. [Use the "Network" function in the User Tools. If there is an IP address conflict, inform the administrator.]</li> </ul>
Between machine and e-mail server	1. LAN settings in the machine	<ul style="list-style-type: none"> <li>▪ Check the LAN parameters</li> <li>▪ Check if there is an IP address conflict with other PCs. [Use the "Network" function in the User Tools. If there is an IP address conflict, inform the administrator.]</li> </ul>

Communication Route	Item	Action [Remarks]
	2. E-mail account on the server	<ul style="list-style-type: none"> <li>▪ Make sure that the machine can log into the e-mail server.</li> <li>▪ Check that the account and password stored in the server are the same as in the machine.</li> </ul> <p>[Ask the administrator to check.]</p>
	3. E-mail server	<ul style="list-style-type: none"> <li>▪ Make sure that the client devices which have an account in the server can send/receive e-mail.</li> </ul> <p>[Ask the administrator to check. Send a test e-mail with the machine's own number as the destination. The machine receives the returned e-mail if the communication is performed successfully.]</p>
Between e-mail server and internet	1. E-mail account on the Server	<ul style="list-style-type: none"> <li>▪ Make sure that the PC can log into the e-mail server.</li> <li>▪ Check that the account and password stored in the server are the same as in the machine.</li> </ul> <p>[Ask the administrator to check.]</p>
	2. E-mail server	<ul style="list-style-type: none"> <li>▪ Make sure that the client devices which have an account in the server can send/receive e-mail.</li> </ul> <p>[Ask the administrator to check. Send a test e-mail with the machine's own number as the destination. The machine receives the returned e-mail if the communication is performed successfully.]</p>
	3. Destination e-mail address	<ul style="list-style-type: none"> <li>▪ Make sure that the e-mail address is actually used.</li> <li>▪ Check that the e-mail address contains no incorrect characters such as spaces.</li> </ul>

Communication Route	Item	Action [Remarks]
	4. Router settings	<ul style="list-style-type: none"> <li>▪ Use the "ping" command to contact the router.</li> <li>▪ Check that other devices connected to the router can send data over the router.</li> </ul> <p>[Ask the administrator of the server to check.]</p>
	5. Error message by e-mail from the network of the destination.	<ul style="list-style-type: none"> <li>▪ Check whether e-mail can be sent to another address on the same network, using the application e-mail software.</li> <li>▪ Check the error e-mail message.</li> </ul> <p>[Inform the administrator of the LAN.]</p>

## 3.4 IP-FAX TROUBLESHOOTING

### 3.4.1 IP-FAX TRANSMISSION

#### *Cannot send by IP Address/Host Name*

Check Point		Action
1	LAN cable connected?	Check the LAN cable connection.
2	Specified IP address/host name correct?	Check the IP address/host name.
3	Firewall/NAT is installed?	Cannot breach the firewall. Send by using another method (Fax, Internet Fax)
4	Transmission sent manually?	Manual sending not supported.
5	IP address of local machine registered?	Register the IP address.
6	Remote terminal port number setting other than 1720 (When using H.323) or 5060 (when using SIP)?	Send by specifying the port number.
7	Specified port number correct?	Confirm the port number of the remote fax.
8	DNS server registered when host name specified?	Contact the network administrator.
9	Remote fax a T.38 terminal?	Check whether the remote fax is a T38 terminal.
10	Remote fax switched off or busy?	Check that the remote fax is switched on.
11	Network bandwidth too narrow?	Request the network administrator to increase the bandwidth.
		Raise the delay level. IPFAX SW 01 Bit 0 to 3

		IP-Fax bandwidth is the same as the DCS speed. Set IP-Fax SW00 Bit 6 to 1.
12	Remote fax cancelled transmission?	Check whether the remote fax cancelled the transmission.

### ***Cannot Send via VoIP Gateway.***

Check Point		Action
1	LAN cable connected?	Check the LAN cable connection.
2	VoIP Gateway T.38 standard?	Contact the network administrator.
3	VoIP Gateway installed correctly?	Contact the network administrator.
4	VoIP Gateway power switched on?	Contact the network administrator.
5	Is the IP address/host name of the specified Gateway correct?	Check the IP address/host name.
6	Number of the specified fax correct?	Check the remote fax number.
7	Firewall/NAT is installed?	Cannot breach the firewall. Send by using another method (Fax, Internet Fax)
8	Transmission sent manually?	Manual sending not supported.
9	IP address of local fax registered?	Register the IP address.
10	DNS registered when host name specified?	Contact the network administrator.
11	Remote fax a G3 fax?	Check that the remote fax is a G3 fax.
12	G3 fax is connected to VoIP gateway?	Check that G3 fax is connected.
13	Remote G3 fax turned on?	Check that G3 fax is switched on.

14	Network bandwidth too narrow?	Request the network administrator to increase the bandwidth.
		Raise the network delay level. IPFAX SW 01 Bit 0 to 3
		IP-Fax bandwidth is the same as the DCS speed. Set IP-Fax SW00 Bit 6 to 1.

**Cannot Send by Alias Fax Number.**

Check Point		Action
1	LAN cable connected?	Check the LAN cable connection.
2	Number of specified Alias fax correct?	Confirm the Alias of the remote fax. Error Code: 13-14
3	Firewall/NAT installed?	Cannot breach the firewall. Send by using another method (Fax, Internet Fax)
4	Transmission sent manually?	Manual sending not supported.
5	Gatekeeper/SIP server installed correctly?	Contact the network administrator.
6	Gatekeeper/SIP server power switched on?	Contact the network administrator.
7	IP address/host name of Gatekeeper/SIP server correct?	Check the IP address/host name.
8	DNS server registered when Gatekeeper/SIP host name specified?	Contact the network administrator.
9	Enable H.323 SW is set to on?	Check the settings. See User Parameter SW 34 Bit 0/SW 34 Bit 1
10	IP address of local fax registered?	Register the IP address of the local fax.



IP-Fax Troubleshooting

11	Alias number of local fax registered?	Register the Alias number of the local fax.
12	Remote fax registered in Gatekeeper?	Contact the network administrator.
13	Remote fax a T.38 terminal?	Check whether the remote fax is a T38 terminal.
14	Remote fax switched off or busy?	Contact the network administrator.
15	Network bandwidth too narrow?	Request the system administrator to increase the bandwidth.
		Raise the delay level. IPFAX SW 01 Bit 0 to 3
		Lower the modem transmission baud rate. IPFAX SW 05
16	Remote fax cancelled transmission?	Check whether the remote fax cancelled the transmission.

### 3.4.2 IP-FAX RECEPTION

#### ***Cannot Receive via IP Address/Host Name.***

Check Point		Action
1	LAN cable connected?	Check the LAN cable connection.
2	Firewall/NAT is installed?	Cannot breach the firewall. Send by using another method (Fax, Internet Fax)
3	IP address of local fax registered?	Register the IP address.
4	Port number specified at remote sender fax (if required)?	Request the sender to specify the port number.
5	Specified port number correct (if required)?	Request the sender to check the port number.
6	DNS server registered when host name specified on sender side?	Contact the network administrator.  <b>Note</b> <ul style="list-style-type: none"> <li>▪ The sender machine displays this error code if the sender fax is a Ricoh model.</li> </ul>
7	Network bandwidth too narrow?	Request the system administrator to increase the bandwidth.
		Lower the start modem reception baud rate on the receiving side. IPFAX SW06
8	Remote fax cancelled transmission?	Check whether the remote fax cancelled the transmission.





#### ***Cannot Receive by VoIP Gateway.***

Check Point		Action
1	LAN cable connected?	Check the LAN cable connection.

## IP-Fax Troubleshooting

2	Firewall/NAT is installed?	Cannot breach the firewall. Request the remote fax to send by using another method (Fax, Internet Fax)
3	VoIP Gateway installed correctly?	Contact the network administrator.
4	VoIP Gateway power switched on?	Contact the network administrator.
5	IP address/host name of specified VoIP Gateway correct on sender's side?	Request the remote fax to check the IP address/host name.
6	DNS server registered when host name specified on sender side?	Contact the network administrator.
7	Network bandwidth too narrow?	Request the network administrator to increase the bandwidth.
8	G3 fax connected?	Check that G3 fax is connected.
9	G3 fax power switched on?	Check that G3 fax is switched on.

**Cannot Receive by Alias Fax Number.**

Check Point		Action
1	LAN cable connected?	Check the LAN cable connection.
2	Firewall/NAT is installed?	Cannot the breach firewall. Request the remote fax to send by using another method (Fax, Internet Fax)
3	Gatekeeper installed correctly?	Contact the network administrator.  <b>Note</b> <ul style="list-style-type: none"> <li>The sender machine displays this error code when the sender fax is a Ricoh model.</li> </ul>
4	Power to Gatekeeper switched on?	Contact the network administrator.  <b>Note</b> <ul style="list-style-type: none"> <li>The sender machine displays this error code when the sender fax is a Ricoh model.</li> </ul>
5	IP address/host name of Gatekeeper correct on the sender's side?	Request the sender to check the IP address/host name.  <b>Note</b> <ul style="list-style-type: none"> <li>The sender machine displays this error code when the sender fax is a Ricoh model.</li> </ul>
6	DNS server registered when Gatekeeper host name specified on sender's side?	Contact the network administrator.  <b>Note</b> <ul style="list-style-type: none"> <li>The sender machine displays this error code when the sender fax is a Ricoh model.</li> </ul>
7	Enable H.323 SW is set to on?	Request the sender to check the settings. User Parameter SW 34 Bit 0/SW 34 bit 1  <b>Note</b> <ul style="list-style-type: none"> <li>Only if the remote sender fax is a Ricoh fax.</li> </ul>

8	Local fax IP address registered?	Register the IP address.
9	Local fax Alias number registered?	Register the Alias number.
10	Network bandwidth too narrow?	Request the system administrator to increase the bandwidth.
		Lower the start modem reception baud rate on the receiving side. IPFAX SW06
11	Remote fax cancelled transmission?	Check whether the remote fax cancelled the transmission.
12	Local fax registered in Gatekeeper/SIP server ?	<p>Contact the network administrator.</p> <p><b>Note</b></p> <ul style="list-style-type: none"> <li>▪ The sender machine displays this error code when the sender fax is a Ricoh model.</li> </ul>

---

## 4. SERVICE TABLES

### 4.1 BEFOREHAND

#### CAUTION

- Never turn off the main power switch when the power LED is lit or flashing. To avoid damaging the hard disk or memory, press the operation power switch to switch the power off, wait for the power LED to go off, and then switch the main power switch off.

#### Note

- The main power LED (Ⓢ) lights or flashes while the platen cover or ARDF is open, while the main machine is communicating with a facsimile or the network server, or while the machine is accessing the hard disk or memory for reading or writing data.

## 4.2 SERVICE TABLES

### 4.2.1 SP1-XXX (BIT SWITCHES)

#### Bit Switches

1	Mode No.	Function
101	System Switch	
	001 – 032	00 – 1F Change the bit switches for system settings for the fax option See "Bit Switches"
102	Ifax Switch	
	001 – 016	00 – 0F Change the bit switches for internet fax settings for the fax option See "Bit Switches"
103	Printer Switch	
	001 – 016	00 – 0F Change the bit switches for printer settings for the fax option See "Bit Switches"
104	Communication Switch	
	001 – 032	00 – 1F Change the bit switches for communication settings for the fax option See "Bit Switches"
105	G3-1 Switch	
	001 – 016	00 – 0F Change the bit switches for the protocol settings of the standard G3 board See "Bit Switches"
111	IP fax Switch	
	001 – 016	00 – 0F Change the bit switches for optional IP fax parameters See "Bit Switches"

**4.2.2 SP2-XXX (RAM)**

<b>2</b>	Mode No.		Function
101	RAM Read/Write		
	001		Change RAM data for the fax board directly. See "Service RAM Addresses"
102	Memory Dump		
	001	G3-1 Memory Dump	Print out RAM data for the fax board. See "Service RAM Addresses"
103	G3-1 NCU Parameters		
	001 – 023	CC, 01 – 22	NCU parameter settings for the standard G3 board. See "NCU Parameters"

**4.2.3 SP3-XXX (MACHINE SET)**

<b>3</b>	Mode No.		Function
101	Service Station		
	001	Fax Number	Enter the fax number of the service station.
102	Serial Number		
	000		Enter the fax unit's serial number.
103	PSTN-1 Port Settings		
	001	Select Line	Select the line type setting for the G3-1 line. If the machine is installed on a PABX line, select "PABX", "PABX(GND)" or "PABX(FLASH)".
	002	PSTN Access Number	Enter the PSTN access number for the G3-1 line.
	003	Memory Lock Disabled	Not used
107	IPFAX Port Settings		



## Service Tables

	001	H323 Port	Sets the H323 port number.
	002	SIP Port	Sets the SIP port number.
	003	RAS Port	Sets the RAS port number.
	004	Gatekeeper port	Sets the Gatekeeper port number.
	005	T.38 Port	Sets the T.38 port number.
	006	SIP Server Port	Sets the SIP port number.
	007	IPFAX Protocol Priority	Select "H323" or "SIP".
201	FAX SW		
	001 – 032	00 – 1F	
301	Fax:FlairAPI Setting		
	101	-	

### 4.2.4 SP4-XXX (ROM VERSION)

4	Mode No.		Function
101	001	FCU ROM Version	Displays the FCU ROM version.
102	001	Error Codes	Displays the latest 64 fax error codes.
103	001	G3-1 ROM Version	Displays the G3-1 modem version.

**4.2.5 SP5-XXX (RAM CLEAR)**

<b>5</b>	Mode No.	Function
101	Initialize SRAM (except Secure)	
	000	Initializes the bit switches and user parameters, user data in the SRAM, files in the SAF memory, and clock.
102	Erase All Files	
	000	Erases all files stored in the SAF memory.
103	Reset Bit Switches (except Secure)	
	000	Resets the bit switches and user parameters.
104	Factory setting	
	000	Resets the bit switches and user parameters, user data in the SRAM and files in the SAF memory.
105	Reset All Bit Switches	
	000	Initializes all the current bit switch settings.
106	Reset Secure Bit Switches	
	000	Initializes only the security bit switches. If you select automatic output/display for the user parameter switches, the security settings are initialized.

## 4.2.6 SP6-XXX (REPORT)

6	Mode No.		Function
101	System Parameter List		
	000	-	Touch the "ON" button to print the system parameter list.
102	Service Monitor Report		
	000	-	Touch the "ON" button to print the service monitor report.
103	G3 Protocol Dump List		
	002	G3-1 (All Communications)	Prints the protocol dump list of all communications for the G3-1 line.
	003	G3-1 (1 Communication)	Prints the protocol dump list of the last communication for the G3-1 line.
105	All Files Print out		
	000	-	Prints out all the user files in the SAF memory, including confidential messages. <span style="color: blue;">⬇ Note</span> <ul style="list-style-type: none"> <li>▪ Do not use this function, unless the customer is having trouble printing confidential messages or recovering files stored using the memory lock feature.</li> </ul>
106	Journal Print out		
	001	All Journals	The machine prints all the communication records on the report.
	002	Specified Date	The machine prints all communication records after the specified date.
107	Log List Print out		
	001	All log files	These log print out functions are for designer

**FAX OPTION  
TYPE M15  
(D3B3)**

	002	Printer	use only.
	003	SC/TRAP Stored	
	004	Decompression	
	005	Scanner	
	006	JOB/SAF	
	007	Reconstruction	
	008	JBIG	
	009	Fax Driver	
	010	G3CCU	
	011	Fax Job	
	012	CCU	
	013	Scanner Condition	
	108	IP Protocol Dump List	
001		All Communications	Prints the protocol dump list of all communications for the IP fax line.
002		1 Communication	Prints the protocol dump list of the last communication for the IP fax line.

### 4.2.7 SP7-XXX (TESTS)

These are the test modes for PTT approval.

7	Function
101	G3-1 Modem Tests
102	G3-1 DTMF Tests
103	Ringer Test
104	G3-1 V34 (S2400baud)
105	G3-1 V34 (S2800baud)
106	G3-1 V34 (S3000baud)
107	G3-1 V34 (S3200baud)
108	G3-1 V34 (S3429baud)
109	Recorded Message Test

## 4.3 BIT SWITCHES - 1

### ⓘ Note

- Do not adjust a bit switch or use a setting that is described as "Not used", as this may cause the machine to malfunction or to operate in a manner that is not accepted by local regulations. Such bits are for use only in other areas, such as Japan.

Default settings for bit switches are not listed in this manual. Refer to the System Parameter List printed by the machine.

### 4.3.1 SYSTEM SWITCHES

System Switch 00 (SP No. 1-101-001)		
No	Function	Comments
0	Dedicated transmission parameter programming 0: Disabled 1: Enabled	Set this bit to 1 before changing any dedicated transmission parameters. This setting is automatically reset to "0" after turning off and on.
1	Not used	Do not change this setting.
2	Technical data printout on the Journal 0: Disabled 1: Enabled	1: Instead of the personal name, the following data are listed on the Journal for each G3 communication.

	<p>Example:</p> <p><b>0000 32V34 288/264 L0100 03 04</b>                  (1) (2)(3) (4) (5) (6) (7) (8)</p> <p>(1): EQM value (Line quality data). A larger number means more errors.                  (2): Symbol rate (V.34 only)                  (3): Final modem type used                  (4): Starting data rate (for example, 288 means 28.8 kbps)                  (5): Final data rate                  (6): Rx level (see below for how to read the rx level)                  (7): Total number of error lines that occurred during non-ECM reception.                  (8): Total number of burst error lines that occurred during non-ECM reception.</p> <p> <b>Note</b></p> <ul style="list-style-type: none"> <li>▪ EQM and rx level are fixed at "FFFF" in tx mode.</li> <li>▪ The seventh and eighth numbers are fixed at "00" for transmission records and ECM reception records.</li> </ul>	
	<p>Rx level calculation</p> <p>Example:</p> <p><b>0000 32V34 288/264 L0100 03 04</b>                  (1) (2)(3) (4) (5) (6) (7) (8)</p> <p>The four-digit hexadecimal value (N) after "L" indicates the rx level.                  The <b>high</b> byte is given first, followed by the <b>low</b> byte. Divide the decimal value of N by -16 to get the rx level.                  In the above example, the decimal value of N (= 0100 [H]) is 256.                  So, the actual rx level is <math>256/-16 = -16</math> dB</p>	
3	Not used	Do not change this setting.
4	Line error mark print 0: OFF, 1: ON (print)	When "1" is selected, a line error mark is printed on the printout if a line error occurs during reception. This shows error locations when ECM is turned off.
5	G3 communication parameter display 0: Disabled 1: Enabled	This is a fault-finding aid. The LCD shows the key parameters (see "G3 Communication Parameters" below this table). This is normally disabled because it cancels the CSI display for the user.  Be sure to reset this bit to "0" after testing.

6	Protocol dump list output after each communication 0: Off 1: On	This is only used for communication troubleshooting. It shows the content of the transmitted facsimile protocol signals. Always reset this bit to 0 after finishing testing.  If system switch 09 bit 6 is at "1", the list is only printed if there was an error during the communication.
7	Not used	Do not change the setting.

### G3 Communication Parameters

Modem rate	336: 33600 bps      168: 16800 bps 312: 31200 bps      144: 14400 bps 288: 28800 bps      120: 12000 bps 264: 26400 bps      96: 9600 bps 240: 24000 bps      72: 7200 bps 216: 21600 bps      48: 4800 bps 192: 19200 bps      24: 2400 bps
Resolution	S: Standard (8 x 3.85 dots/mm) D: Detail (8 x 7.7 dots/mm) F: Fine (8 x 15.4 dots/mm) SF: Superfine (16 x 15.4 dots/mm) 21: Standard (200 x 100 dpi) 22: Detail (200 x 200 dpi) 44: Superfine (400 x 400 dpi)
Compression mode	MMR: MMR compression MR: MR compression MH: MH compression JBO: JBIG compression (Optional mode) JBB: JBIG compression (Basic mode)
Communication mode	ECM: With ECM NML: With no ECM
Width and reduction	A4: A4 (8.3"), no reduction B4: B4 (10.1"), no reduction A3: A3 (11.7"), no reduction



I/O rate	<p>0: 0 ms/line                      5: 5 ms/line                      10: 10 ms/line                      20: 20 ms/line                      25: 2.5 ms/line                      40: 40 ms/line</p> <p><b>Note</b></p> <ul style="list-style-type: none"> <li>▪ "40" is displayed while receiving a fax message using AI short protocol.</li> </ul>
----------	--

**System Switch 01** - Not used (Do not change the factory settings.)

<b>System Switch 02 (SP No. 1-101-003)</b>		
No	Function	Comments
0-1	Not used	Do not change these settings.
2	Forced reset after transmission stalls 0: Off 1: On	With this setting on, the machine resets itself automatically if a transmission stalls and fails to complete the job.
3	Not used	Do not change these settings.
4	File retention time 0: Depends on User Parameter 24 [18(H)] 1: No limit	1: A file that had a communication error will not be erased unless the communication is successful.
5-7	-	Do not change this setting

**System Switch 03** - Not used (Do not change the factory settings.)

**System Switch 04 (SP No. 1-101-005)**

No	Function	Comments
0-2	Not used	Do not change these settings.
3	Printing dedicated tx parameters on Quick/Speed Dial Lists 0: Disabled 1: Enabled	1: Each Quick/Speed dial number on the list is printed with the dedicated tx parameters (10 bytes each). The first 10 bytes of data are the programmed dedicated tx parameters; 34 bytes of data are printed (the other 24 bytes have no use for service technicians).
4-7	Not used	Do not change these settings.

**System Switch 05** - Not used (Do not change the factory settings.)

**System Switch 06** - Not used (Do not change the factory settings.)

**System Switch 07** - Not used (Do not change the factory settings.)

**System Switch 08** - Not used (Do not change the factory settings.)

**System Switch 09 (SP No. 1-101-010)**

No	Function	Comments
0	Addition of image data from confidential transmissions on the transmission result report 0: Disabled 1: Enabled	If this feature is enabled, the top half of the first page of confidential messages will be printed on transmission result reports.
1	Print timing of communication reports on the Journal when no image data was exchanged. 0: After DCS/NSS communication (default), 1: After polling	0: The Journal is printed only when image data is sent. 1: The Journal is printed when any data is sent.

Bit Switches - 1

2	Automatic error report printout 0: Disabled 1: Enabled	0: Error reports will not be printed. 1: Error reports will be printed automatically after failed communications.
3	Printing of the error code on the error report 0: No 1: Yes	1: Error codes are printed on the error reports. This can be used for detecting an error which occurs rarely.
4	Not used	Do not change this setting.
5	Power failure report 0: Disabled 1: Enabled (default)	1: A power failure report will be automatically printed after the power is switched on if a fax message disappeared from the memory when the power was turned off last. <b>NOTE:</b> If "0" is selected, no reports are printed and no one may recognize that fax data is gone due to a power failure.
6	Conditions for printing the protocol dump list 0: Print for all communications 1: Print only when there is a communication error	This switch becomes effective only when system switch 00 bit 6 is set to 1. 1: Set this bit to 1 when you wish to print a protocol dump list only for communications with errors. <b>NOTE:</b> The memory size is limited. Use this bit switch only when some log reports are necessary.
7	Not used	Do not change this setting.

FAX OPTION  
TYPE M15  
(D3B3)

<b>System Switch 0A (SP No. 1-101-011)</b>		
<b>No</b>	<b>Function</b>	<b>Comments</b>
0	Automatic port selection 0: Disabled, 1: Enabled	When "1" is selected, a suitable port is automatically selected if the selected port is not used.  <b>NOTE:</b> This bit is useful if all communication lines at a customer site are not the same quality
1-3	Not used	Do not change these settings.
4	Dialing on the ten-key pad when the external telephone is off-hook 0: Disabled 1: Enabled	0: Prevents dialing from the ten-key pad while the external telephone is off-hook. Use this setting when the external telephone is not by the machine, or if a wireless telephone is connected as an external telephone. 1: The user can dial on the machine's ten-key pad when the handset is off-hook.
5	On hook dial 0: Disabled 1: Enabled	0: On hook dial is disabled.
6-7	Not used	Do not change these settings

<b>System Switch 0B</b> - Not used (Do not change the factory settings.)
<b>System Switch 0C</b> - Not used (Do not change the factory settings.)
<b>System Switch 0D</b> - Not used (Do not change the factory settings.)

<b>System Switch 0E (SP No. 1-101-015)</b>		
<b>No</b>	<b>Function</b>	<b>Comments</b>
0-1	Not used	Do not change the settings.
2	Enable/disable for direct sending selection 0: Direct sending off 1: Direct sending on	Direct sending cannot operate when the capture function is on during sending. Setting this switch to "1" enables direct sending without capture.  Setting this switch to "0" masks the direct sending function on the operation panel so direct sending with ScanRouter cannot be selected.
3	Action when the external handset goes off-hook 0: Manual tx and rx operation 1: Memory tx and rx operation (the display remains the same)	0: Manual tx is possible while the external handset is off-hook. However, manual tx during handset off-hook may not be sent to a correct direction. Manual tx is not possible.  1: The display stays in standby mode even when the external handset is used, so that other people can use the machine for memory tx operation. Note that manual tx and rx are not possible with this setting.
4-7	Not used	Do not change these settings.

**FAX OPTION  
TYPE M15  
(D3B3)**

System Switch 0F (SP No. 1-101-016)			
No	Function	Comments	
0 to 7	Country/area code for functional settings (Hex)	This country/area code determines the factory settings of bit switches and RAM addresses. However, it has no effect on the NCU parameter settings and communication parameter RAM addresses. Cross reference NCU country code: SP No. 2-103-001 for G3-1 SP No. 2-104-001 for G3-2 SP No. 2-105-001 for G3-3	
	00: France		12: Asia
	01: Germany		13: Japan
	02: UK		14: Hong Kong
	03: Italy		15: South Africa
	04: Austria		16: Australia
	05: Belgium		17: New Zealand
	06: Denmark		18: Singapore
	07: Finland		19: Malaysia
	08: Ireland		1A: China
	09: Norway		1B: Taiwan
	0A: Sweden		1C: Korea
	0B: Switz.		1D: Brazil
	0C: Portugal		20: Turkey
	0D: Holland		21: Greece
	0E: Spain		22: Hungary
0F: Israel	23: Czech		
10: ---	24: Poland		
11: USA			

System Switch 10 (SP No. 1-101-017)		
No	Function	Comments
0-7	Threshold memory level for parallel memory transmission	Threshold = N x 128 KB + 256 KB N can be between 00 - FF(H) Default setting: 02(H) = 512 KB

System Switch 11 (SP No. 1-101-018)		
No	Function	Comments
0	TTI printing position 0: Superimposed on the page data 1: Printed before the data leading edge	Change this bit to 1 if the TTI overprints information that the customer considers to be important (G3 transmissions). <b>NOTE:</b> If "1" is selected, it is possible that sent data is printed on two sheets of paper.
1-2	Not used	Do not change these settings.
3	TTI used for broadcasting 0: The TTIs selected for each Quick/Speed dial are used 1: The same TTI is used for all destinations	1: The TTI (TTI_1 or TTI_2) which is selected for all destinations during broadcasting.
4-7	Not used	Do not change these settings.

<b>System Switch 12 (SP No. 1-101-019)</b>		
<b>No</b>	<b>Function</b>	<b>Comments</b>
0-7	TTI printing position in the main scan direction	TTI: 08 to 92 (BCD) mm Input even numbers only. This setting determines the print start position for the TTI from the left edge of the paper. If the TTI is moved too far to the right, it may overwrite the file number which is on the top right of the page. On an A4 page, if the TTI is moved over by more than 50 mm, it may overwrite the page number.

**System Switch 13** - Not used (do not change these settings)

**System Switch 14** - Not used (do not change these settings)

<b>System Switch 15 (SP No. 1-101-022)</b>		
<b>No</b>	<b>Function</b>	<b>Comments</b>
0	Not used	Do not change the settings.
1	Going into the Energy Saver mode automatically 0: Enabled 1: Disabled	1: The machine will restart from the Energy Saver mode quickly, because the +5V power supply is active even in the Energy Saver mode. The LED of the operation switch is flashing instead of entering Energy Saver mode. Use this setting if an external telephone has to be used when the machine is in the Energy Saver mode.
2-3	Not used	Do not change these settings.
4-5	Interval for preventing the machine from entering Energy Saver mode if there is a pending transmission file.	If there is a file waiting for transmission, the machine does not go to Energy Saver mode during the selected period. After transmitting the file, if there is no file



	Bit 5	Bit 4	Setting	waiting for transmission, the machine goes to the Energy Saver mode.
	0	0	1 min	
	0	1	30 min	
	1	0	1 hour	
	1	1	24 hours	
6-7	Not used		Do not change	

<b>System Switch 16 (SP No. 1-101-023)</b>		
No	Function	Comments
0	Parallel Broadcasting 0: Disabled 1: Enabled	1: The machine sends messages simultaneously using all available ports during broadcasting.  <b>NOTE:</b> If a customer wants to keep a line available for fax reception or other reasons, select "0" (Disable).
1	Priority setting for the G3 line. 0: PSTN-1 > PSTN-2 or 3 1: PSTN-2 or 3 > PSTN-1	This function allows the user to select the default G3 line type. The optional SG3 units are required to use the PSTN-2 or 3 setting.
2-7	Not used	Do not change these settings.

**System Switch 17** - Not used (do not change these settings)

**System Switch 18** - Not used (do not change these settings)

System Switch 19 (SP No. 1-101-026)		
No	Function	Comments
0-5	Not used	Do not change the settings.
6	Extended scanner page memory after memory option is installed 0: Disabled 1: Enabled	0: After installing the memory expansion option, the scanner page memory is extended to 4 MB from 2 MB. 1: If this bit is set to 1 after installing the memory expansion option, the scanner page memory is extended to 12 MB. But the SAF memory decreases to 18 MB.
7*	Special Original mode 0: Disabled 1: Enabled	1: If the customer frequently wishes to transmit a form or letterhead which has a colored or printed background, change this bit to "1". "Original 1" and "Original 2" can be selected in addition to the "Text", "Text/Photo" and "Photo" modes.

\* This setting can be used for the client machine which has no FCU.

System Switch 1A (SP No. 1-101-027)		
No	Function	Comments
0 to 7	LS RX memory capacity threshold setting 00-FF (0-1020 Kbyte: Hex)	Sets the value to x4KB. When the amount of available memory drops below this setting, RX documents are printed to conserve memory. Initial setting 0x80 (512 KB) <b>NOTE:</b> If a customer wants available memory size to be larger, decrease this threshold

**System Switch 1B** - Not used (do not change these settings)

**System Switch 1C** - Not used (do not change these settings)

System Switch 1D (SP No. 1-101-030)		
No	Function	Comments
0	RTI/CSI/CPS code display 0: Enable 1: Disable	0: RTI, CSI, CPS codes are displayed on the top line of the LCD panel during communication. 1: Codes are switched off (no display)
1-7	Not used	Do not change these settings.

System Switch 1E (SP No. 1-101-031)		
No	Function	Comments
0	Communication after the Journal data storage area has become full 0: Impossible 1: Possible	0: When this switch is on and the journal history becomes full, the next report prints. If the journal history is not deleted, the next transmission cannot be received. This prevents overwriting communication records before the machine can print them. 1: If the buffer memory of the communication records for the Journal is full, fax communications are still possible. But the machine will overwrite the oldest communication records. <b>Note</b> <ul style="list-style-type: none"> <li>This setting is effective only when Automatic Journal printout is enabled but the machine cannot print the report (e.g., no paper).</li> </ul>

1*	Action when the SAF memory has become full during scanning 0: The current page is erased. 1: The entire file is erased.	0: If the SAF memory becomes full during scanning for a memory transmission, the successfully scanned pages are transmitted. 1: If the SAF memory becomes full during scanning for a memory transmission, the file is erased and no pages are transmitted.   <b>Note</b> <ul style="list-style-type: none"> <li>This setting is effective only when Automatic Journal printout is enabled but the machine cannot print the report (e.g., no paper).</li> </ul>
2	RTI/CSI display priority 0: RTI 1: CSI	This bit determines which identifier, RTI or CSI, is displayed on the LCD while the machine is communicating in G3 non-standard mode.
3	File No. printing 0: Enabled 1: Disabled	1: File numbers are not printed on any reports. <b>NOTE:</b> The file numbers may not be printed in the sequential order. If a customer does not like this numbering, select "0".
4	Action when authorized reception is enabled but authorized RTIs/CSIs are not yet programmed 0: All fax reception is disabled 1: Faxes can be received if the sender has an RTI or CSI	0: If the user has stored no acceptable sender RTIs or CSIs, the user can select "ON" in the authorized reception setting but the setting becomes invalid ("OFF"). The machine will not be able to receive any fax messages. If the customer wishes to receive messages from any sender that includes an RTI or CSI, and to block messages from senders that do not include an RTI or CSI, change this bit to "0", then enable Authorized Reception. Otherwise, keep this bit at "1 (default setting)".
5-7	Not used	Do not change the settings

\* This setting can be used for the client machine which has no FCU.

<b>System Switch 1F (SP No. 1-101-032)</b>		
<b>No</b>	<b>Function</b>	<b>Comments</b>
0	Not used	Do not change the settings.
1	Report printout after an original jam during SAF storage or if the SAF memory fills up 0: Enabled 1: Disabled	0: When an original jams, or the SAF memory overflows during scanning, a report will be printed. Change this bit to "1" if the customer does not want to have a report in these cases. Memory tx – Memory storage report Parallel memory tx – Transmission result report
2	Not used	Do not change the settings.
3	Received fax print start timing (G3 reception) 0: After receiving each page 1: After receiving all pages	0: The machine prints each page immediately after the machine receives it. 1: The machine prints the complete message after the machine receives all the pages in the memory.
4-6	Not used	Do not change the factory settings.
7	Action when a fax SC has occurred 0: Automatic reset 1: Fax unit stops	0: When the fax unit detects a fax SC code other than SC1201 and SC1207, the fax unit automatically resets itself. 1: When the fax unit detects any fax SC code, the fax unit stops. <b>Cross Reference</b> Fax SC codes - See "Troubleshooting"

## 4.4 BIT SWITCHES - 2

### Note

- Do not adjust a bit switch or use a setting that is described as "Not used", as this may cause the machine to malfunction or to operate in a manner that is not accepted by local regulations. Such bits are for use only in other areas, such as Japan.

Default settings for bit switches are not listed in this manual. Refer to the System Parameter List printed by the machine.

### 4.4.1 I-FAX SWITCHES

I-fax Switch 00 (SP No. 1-102-001)		
No	Function	Comments
Original Width of TX Attachment File		This setting sets the maximum size of the original that the destination can receive. (Bits 3 to 6 are reserved for future use or not used.)
0	A4	-
1	B4	
2	A3	
3-6	Reserved	
7	Not used	
<p>0: Off (not selected), 1: On (selected)</p> <p>If more than one of these three bits is set to "1", the larger size has priority. For example, if both Bit 2 and Bit 1 are set to "1" then the maximum size is "A3" (Bit 2).</p> <p>When mail is sent, there is no negotiation with the receiving machine at the destination, so the sending machine cannot make a selection for the receiving capabilities (original width setting) of the receiving machine. The original width selected with this switch is used as the RX machine's original width setting, and the original is reduced to this size before sending. The default is A4.</p> <p>If the width selected with this switch is higher than the receiving machine can accept, the machine detects this and this causes an error.</p>		

<b>I-fax Switch 01 (SP No. 1-102-002)</b>		
<b>No</b>	<b>Function</b>	<b>Comments</b>
Original Line Resolution of TX Attachment File		These settings set the maximum resolution of the original that the destination can receive.
0	200x100 Standard	0: Not selected 1: Selected If more than one of these three bits is set to "1", the higher resolution has priority. For example, if both Bit 0 and Bit 2 are set to "1" Then The Resolution is set for "Bit 2 200 x 400.
1	200x200 Detail	
2	200x400 Fine	
3	300 x 300 Reserve	
4	400 x 400 Super Fine	
5	600 x 600 Reserve	
6	Reserve	
7	mm/inch	
<p>This setting selects mm/inch conversion for mail transmission.                      0: Off (No conversion), 1: On (Conversion)                      When on (set to "1"), the machine converts millimeters to inches for sending mail. There is no switch for converting inches to millimeters.                      Unlike G3 fax transmissions which can negotiate between sender and receiver to determine the setting, mail cannot negotiate between terminals; the mm/inch selection is determined by the sender fax.                      When this switch is Off (0):</p> <ul style="list-style-type: none"> <li>▪ Images scanned in inches are sent in inches.</li> <li>▪ Images scanned in mm are sent in mm.</li> <li>▪ Images received in inches are transmitted in inches.</li> <li>▪ Images received in mm are transmitted in mm.</li> </ul> <p>When this switch is On (1):</p> <ul style="list-style-type: none"> <li>▪ Images scanned in inches are sent in inches.</li> <li>▪ Images scanned in mm are converted to inches.</li> <li>▪ Images received in inches are transmitted in inches.</li> <li>▪ Images received in mm are converted to inches.</li> </ul>		

I-fax Switch 02 (SP No. 1-102-003)		
No	Function	Comments
0	RX Text Mail Header Processing	
		<p>This setting determines whether the header information is printed with text e-mails when they are received.</p> <p>0: Prints only text mail.</p> <p>1: Prints mail header information attached to text mail.</p> <p>When a text mail is received with this switch On (1), the "From" address and "Subject" address are printed as header information.</p> <p>When a mail with only binary data is received (a TIFF-F file, for example), this setting is ignored and no header is printed.</p>
1	Output from Attached Document at E-mail TX Error	
		<p>This setting determines whether only the first page or all pages of an e-mail attachment are printed at the sending station when a transmission error occurs.</p> <p>This allows the customer to see which documents have not reached their intended destinations if sent to the wrong e-mail addresses, for example.</p> <p>0: Prints 1st page only.</p> <p>1: Prints all pages.</p>
2-3	Text String for Return Receipt	
		<p>This setting determines the text string output for the Return Receipt that confirms the transmission was received normally at the destination.</p>



	<p>00: "Dispatched" Sends from PC mail a request for a Return Receipt. Receives the Return Receipt with "dispatched" in the 2nd part: Disposition: Automatic-action/MDN-send automatically; dispatched The "dispatched" string is included in the Subject string.</p> <p>01: "Displayed" Sends from PC mail a request for a Return Receipt. Receives the Return Receipt with "displayed" in the 2nd part: Disposition: Automatic-action/MDN-send automatically; displayed The "displayed" string is included in the Subject string.</p> <p>10: Reserved 11: Reserved</p> <p>A mail requesting a Return Receipt sent from an IFAX with this switch set to "00" (for "dispatched") received by Microsoft Outlook 2000 may cause an error. If any setting other than "displayed" (01) causes a problem, change the setting to "01" to enable normal sending of the Return Receipt.</p>
4	<p>Media accept feature</p> <p>This setting adds or does not add the media accept feature to the answer mail to confirm a reception.</p> <p>0: Does not add the media accept feature to the answer mail 1: Adds the media accept feature to the answer mail.</p> <p>Use this bit switch if a problem occurs when the machine receives an answer mail, which contains the media accept feature field.</p>
5-6	Not Used
7	<p>Image Resolution of RX Text Mail</p> <p>This setting determines the image resolution of the received mail.</p> <p>0: 200 x 200 1: 400 x 400</p> <p>The "1" setting requires installation of the Memory Unit in order to have enough SAF (Store and Forward) memory to receive images at 400 x 400 resolution.</p>

**I-fax Switch 03** - Not used (do not change these settings)

I-fax Switch 04 (SP No. 1-102-005)		
No	Function	Comments
0	Subject for Delivery TX/Memory Transfer	<p>This setting determines whether the RTI/CSI registered on this machine or the RTI/CSI of the originator is used in the subject lines of transferred documents.</p> <p>0: Puts the RTI/CSI of the originator in the Subject line. If this is used, either the RTI or CSI is used. Only one of these can be received for use in the subject line.</p> <p>1: Puts the RTI/CSI registered on this machine in the Subject line.</p> <p>When this switch is used to transfer and deliver mail to a PC, the information in the Subject line that indicates where the transmission originated can be used to determine automatically the destination folder for each e-mail.</p>
1	Subject corresponding to mail post database	<p>0: Standard subject</p> <p>1: Mail post database subject</p> <p>The standard subject is replaced by the mail post database subject in the following three cases:</p> <ol style="list-style-type: none"> <li>1) When the service technician sets the service (software) switch.</li> <li>2) When memory sending or delivery specified by F code is applied by the SMTP server</li> <li>3) With relay broadcasting (1st stage without the Schmidt 4 function).</li> </ol> <p><b>Note</b></p> <ul style="list-style-type: none"> <li>▪ This switch does not apply for condition 3) when the RX system is set up for memory sending, delivery by F-code, sending with SMTP RX and when operators are using FOL (to prevent problems when receiving transmissions).</li> </ul>
2-7	Not Used	

<b>I-fax Switch 05 (SP No. 1-102-006)</b>		
<b>No</b>	<b>Function</b>	<b>Comments</b>
0	Mail Addresses of SMTP Broadcast Recipients	<p>Determines whether the e-mail addresses of the destinations that receive transmissions broadcasted using SMTP protocol are recorded in the Journal.</p> <p>For example:                      "1st destination + Total number of destinations: 9" in the Journal indicates a broadcast to 9 destinations.</p> <p>0: Not recorded                      1: Recorded</p>
1	IFAXTX Retries	<p>Determines whether the machine retries sending IFAX when connection and transmission fails due to errors.</p> <p>0: Disabled                      1: Enabled</p>
2	Size Setting: Tiff: Mail/Folder	<p>Enables or Disables a function which adjusts the file size of a TIFF file sent from Fax application.</p> <p>0: OFF (Disable)                      1: ON (Enable)</p>
3-7	Not Used	

FAX OPTION  
TYPE M15  
(D3B3)

I-fax Switch 06 (SP No. 1-102-007)		
No	Function	Comments
2	Main scan size adjustment	
	<p>The paper sizes that T.37 (Internet FAX) required are different from the regular paper sizes. Some PC applications cannot recognize a received Tiff file as a regular paper size. If this bit switch is enabled, the transmission paper size is adjusted the regular paper size except the internet FAX transmission.</p> <p>0: Disabled (default) 1: Enabled</p> <p><b>Regular paper size:</b> A4: 210 mm +/-2.0 mm B4: 257 mm +/-2.0 mm A3: 298 mm +/-2.0 mm</p> <p><b>Internet FAX (T.37):</b> A4: 215 mm +/-1% B4: 255 mm +/-1% A3: 303 mm +/-1%</p>	
0-1 3-7	Not used.	

**I-fax Switch 07** - Not used (do not change the settings)

I-fax Switch 08 (SP No. 1-102-009)		
No	Function	Comments
0-7	Memory Threshold for POP Mail Reception	
	<p>This setting determines the amount of SAF (Store and Forward) memory. (SAF stores fax messages to send later for transmission to more than one location, and also holds incoming messages if they cannot be printed.) When the amount of SAF memory available falls below this setting, mail can no longer be received; received mail is then stored on the mail server.</p> <p>00-FF (0 to 1024 KB: HEX)</p> <p>The hexadecimal number you enter is multiplied by 4 KB to determine the amount of memory.</p>	

<b>I-fax Switch 09 (SP No. 1-102-010)</b>		
<b>No</b>	<b>Function</b>	<b>Comments</b>
0-3	Not used	Do not change the settings
4-7	Restrict TX Retries	This setting determines the number of retries when connection and transmission fails due to errors. 01-F (1-15 Hex)

<b>I-fax Switch 0A</b> - Not used (do not change the settings)
<b>I-fax Switch 0B</b> - Not used (do not change the settings)
<b>I-fax Switch 0C</b> - Not used (do not change the settings)

<b>I-fax Switch 0D (SP No. 1-102-014)</b>				
<b>No</b>	<b>Function</b>			<b>Comments</b>
0-1	Not used			Do not change the settings
2-3	Select the signature when sending mail notification of the send results			In response to IEEE2600.1.
	Bit 2	Bit 3	Setting	
	0	0	No sign	
	0	1	No setting	
	1	0	Individual setting	
	1	1	Always sign	
4-5	Select the signature when sending mail.			In response to IEEE2600.1.
	Bit 5	Bit 4	Setting	
	0	0	No sign	
	0	1	No setting	
	1	0	Individual setting	

	1	1	Always sign	
6-7	Not used			Do not change the settings.

**I-fax Switch 0E** - Not used (do not change the settings)

<b>I-fax Switch 0F (SP No. 1-102-016)</b>		
<b>No</b>	<b>Function</b>	<b>Comments</b>
0	Delivery Method for SMTP RX Files	
	This setting determines whether files received with SMTP protocol are delivered or output immediately. 0: Off. Files received via SMTP are output immediately without delivery. 1: On. Files received via SMTP are delivered immediately to their destinations.	
1	Set to select the signature when receiving SMTP mail.	
	0: No sign 1: Always sign	
2	Set to encrypt the data when receiving SMTP mail.	
	0: No encryption 1: Encryption	
3-7	Not used	

**FAX OPTION  
 TYPE M15  
 (D3B3)**

## 4.4.2 PRINTER SWITCHES

Printer Switch 00 (SP No. 1-103-001)		
No	Function	Comments
0	Select page separation marks 0: Off 1: On	0: If a 2 page RX transmission is split, [*] is printed in the bottom right corner of the 1st page and only a [2] is printed in the upper right corner of the 2nd page. 1: If a 2 page RX transmission is split into two pages, for example, [*] [2] is printed in the bottom right corner of the 1st page and only a [2] is printed in the upper right corner of the 2nd page. <b>Note</b> <ul style="list-style-type: none"> <li>This helps the user to identify pages that have been split because the size of the paper is smaller than the size of the document received. (When A5 is used to print an A4 size document, for example.)</li> </ul>
1	Repetition of data when the received page is longer than the printer paper 0: Off 1: On	1: Default. 10 mm of the trailing edge of the previous page are repeated at the top of the next page. 0: The next page continues from where the previous page stopped without any repeated text.
2	Prints the date and time on received fax messages 0: Disabled 1: Enabled	This switch is only effective when user parameter 02 - bit 2 (printing the received date and time on received fax messages) is enabled. 1: The machine prints the received and printed date and time at the bottom of each received page.
3-7	Not used	Do not change the settings.

Printer Switch 01 (SP No. 1-103-002)				
No	Function		Comments	
0-2	Not used		Do not change the settings.	
3-4	Maximum print width used in the setup protocol		These bits are only effective when bit 7 of printer switch 01 is "1".	
	Bit 4	Bit 3		Setting
	0	0		Not used
	0	1		A3
	1	0		B4
	1	1	A4	
5-6	Not used		Do not change the settings.	
7	Received message width restriction in the protocol signal to the sender 0: Disabled 1: Enabled		0: The machine informs the transmitting machine of the print width depending on the paper size available from the paper feed stations. Refer to the table on the next page for how the machine chooses the paper width used in the setup protocol (NSF/DIS). 1: The machine informs the transmitting machine of the fixed paper width which is specified by bits 3 and 4 above.	

#### Relationship between available paper sizes and printer width used in the setup protocol

Available Paper Size	Printer width used in the Protocol (NSF/DIS)
A4 or 8.5" x 11"	297 mm width
B5	256 mm width
A5 or 8.5" x 5.5"	216 mm width
No paper available (Paper end)	216 mm width



Printer Switch 02 (SP No. 1-103-003)		
No	Function	Comments
0*	1st paper feed station usage for fax printing 0: Enabled 1: Disabled	<p>0: The paper feed station can be used to print fax messages and reports. 1: The specified paper feed station will not be used for printing fax messages and reports.</p> <p><b>Note</b></p> <ul style="list-style-type: none"> <li>Do not disable usage for a paper feed station which has been specified by User Parameter Switch 0F (15), or which is used for the Specified Cassette Selection feature.</li> </ul>
1*	2nd paper feed station usage for fax printing 0: Enabled 1: Disabled	
2*	3rd paper feed station usage for fax printing 0: Enabled 1: Disabled	
3*	4th paper feed station usage for fax printing 0: Enabled 1: Disabled	
4*	LCT usage for fax printing 0: Enabled 1: Disabled	
5-7	Not used	

\* This setting can be used for the client-side machine which has no FCU.

FAX OPTION  
TYPE M15  
(D3B3)

Printer Switch 03 (SP No. 1-103-004)		
No	Function	Comments
0*	Length reduction of received data 0: Disabled 1: Enabled	0: Incoming pages are printed without length reduction. (Page separation threshold: Printer Switch 03, bits 4 to 7) 1: Incoming page length is reduced when printing. (Maximum reducible length: Printer Switches 04, bits 0 to 4)
1-3	Not used	Do not change the settings
4 to 7	Page separation setting when sub scan compression is forbidden 00-0F (0-15 mm: Hex) Default: 6 mm	Page separation threshold (with reduction disabled with switch 03-0 above). For example, if this setting is set to "10", and A4 is the selected paper size: If the received document is 10 mm or less longer than A4, then the 10 mm are cut and only 1 page prints. If the received document is 10 mm longer than A4, then the document is split into 2 pages.

\* This setting can be used for the client-side machine which has no FCU.

Printer Switch 04 (SP No. 1-103-005)						
No	Function			Comments		
0 to 4	Maximum reducible length when length reduction is enabled with switch 03-0 above.			[Maximum reducible length] = [Paper length] + (N x 5mm) "N" is the decimal value of the binary setting of bits 0 to 4.		
	Bit 4	Bit 3	Bit 2	Bit 1	Bit 0	Setting
	0	0	0	0	0	0 mm
	0	0	0	0	1	5 mm

	0	0	1	0	0	20 mm
	1	1	1	1	1	155 mm
For A5 sideways and B5 sideways paper [Maximum reducible length] = [Paper length] + 0.75 x (N x 5mm)						
5 6	Length of the duplicated image on the next page, when page separation has taken place.					
	Bit 6		Bit 5		Setting	
	0		0		4 mm	
	0		1		10 mm	
	1		0		15 mm	
	1		1		Not used	
7	Not used.			Do not change the setting.		

**Printer Switch 05** - Not used (do not change the settings)

**Printer Switch 06 (SP No. 1-103-007)**

No	Function	Comments
0*	Printing while a paper cassette is pulled out, when the Just Size Printing feature is enabled. 0: Printing will not start 1: Printing will start if another cassette has a suitable size of paper, based on the paper size selection priority tables.	Cross reference Just size printing on/off – User switch 05, bit 5
1-7	Not used.	Do not change the settings.

\* This setting can be used for the client-side machine which has no FCU.

<b>Printer Switch 07 (SP No. 1-103-008)</b>		
<b>No</b>	<b>Function</b>	<b>Comments</b>
0-3	Not used.	Do not change the settings.
4	Receiver name printed on the transmission result report	Selects the printing target on the transmission result report. 0: All receivers 1: Printing only receivers which have received fax transmission.
5-7	Not used.	Do not change the settings.

**Printer Switch 08** - Not used (do not change the settings)

**Printer Switch 09** - Not used (do not change the settings)

**Printer Switch 0A** - Not used (do not change the settings)

**Printer Switch 0B** - Not used (do not change the settings)

**Printer Switch 0C** - Not used (do not change the settings)

<b>Printer Switch 0E (SP No. 1-103-015)</b>		
<b>No</b>	<b>Function</b>	<b>Comments</b>
0*	Paper size selection priority 0: Width 1: Length	0: A paper size that has the same width as the received data is selected first. 1: A paper size which has enough length to print all the received lines without reduction is selected first.
1*	Paper size selected for printing A4 width fax data 0: 8.5" x 11" size 1: A4 size	This switch determines which paper size is selected for printing A4 width fax data, when the machine has both A4 and 8.5" x 11" size paper.

2	<p>Page separation</p> <p>0: Enabled</p> <p>1: Disabled</p>	<p>1: If all paper sizes in the machine require page separation to print a received fax message, the machine does not print the message (Substitute Reception is used). After a larger size of paper is set in a cassette, the machine automatically prints the fax message.</p>		
3-4	<p>Printing the sample image on reports</p>	<p>"Same size" means the sample image is printed at 100%, even if page separation occurs.</p> <p>User Parameter Switch 19 (13H) bit 4 must be set to "0" to enable this switch. Refer to Detailed Section Descriptions for more on this feature.</p>		
	<p>Bit 4</p>		<p>Bit 3</p>	<p>Setting</p>
	<p>0</p>		<p>0</p>	<p>The upper half only</p>
	<p>0</p>		<p>1</p>	<p>50% reduction (sub-scan only)</p>
	<p>1</p>		<p>0</p>	<p>Same size</p>
<p>1</p>	<p>1</p>	<p>Not used</p>		
5-6	<p>Not used</p>	<p>Do not change the settings.</p>		
7	<p>Equalizing the reduction ratio among separated pages (Page Separation)</p> <p>0: Enabled</p> <p>1: Disabled</p>	<p>0: When page separation has taken place, all the pages are reduced with the same reduction ratio.</p> <p>1: Only the last page is reduced to fit the selected paper size when page separation has taken place. Other pages are printed without reduction.</p>		

\* This setting can be used for the client-side machine which has no FCU.

Printer Switch 0F (SP No. 1-103-016)				
No	Function			Comments
0-1*	Smoothing feature			(0, 0) (0, 1): Disable smoothing if the machine receives halftone images from other manufacturers fax machines frequently.
	Bit 1	Bit 0	Setting	
	0	0	Disabled	
	0	1	Disabled	
	1	0	Enabled	
	1	1	Not used	
2*	Duplex printing 0: Disabled 1: Enabled			1: The machine always prints received fax messages in duplex printing mode:
3	Binding direction for Duplex printing 0: Left binding 1: Top binding			0: Sets the binding for the left edge of the stack. 1: Sets the binding for the top of the stack.
4-7	Not used			Do not change the settings.

\* This setting can be used for the client-side machine which has no FCU.

## 4.5 BIT SWITCHES – 3

### ⓘ Note

- Do not adjust a bit switch or use a setting that is described as "Not used", as this may cause the machine to malfunction or to operate in a manner that is not accepted by local regulations. Such bits are for use only in other areas, such as Japan.

Default settings for bit switches are not listed in this manual. Refer to the System Parameter List printed by the machine.

### 4.5.1 COMMUNICATION SWITCHES

Communication Switch 00 (SP No. 1-104-001)				
No	Function		Comments	
0-1	Compression modes available in receive mode		These bits determine the compression capabilities to be declared in phase B (handshaking) of the T.30 protocol.	
	Bit 1	Bit 0		Modes
	0	0		MH only
	0	1		MH/MR
	1	0		MH/MR/MMR
	1	1		MH/MR/MMR/JBIG
2-3	Compression modes available in transmit mode		These bits determine the compression capabilities to be used in the transmission and to be declared in phase B (handshaking) of the T.30 protocol.	
	Bit 3	Bit 2		Modes
	0	0		MH only
	0	1		MH/MR
	1	0		MH/MR/MMR
	1	1		MH/MR/MMR/JBIG

FAX OPTION  
TYPE M15  
(D3B3)

4	Not used	Do not change the settings.
5	JBIG compression method: Reception 0: Only basic supported 1: Basic and optional both supported	Change the setting when communication problems occur using JBIG compression.
6	JBIG compression method: Transmission 0: Basic mode priority 1: Optional mode priority	Change the setting when communication problems occur using JBIG compression.
7	Closed network (reception) 0: Disabled 1: Enabled	1: Reception will not go ahead if the polling ID code of the remote terminal does not match the polling ID code of the local terminal. This function is only available in NSF/NSS mode.

Communication Switch 01 (SP No. 1-104-002)				
No	Function		Comments	
0	ECM 0: Off 1: On		If this bit is set to 0, ECM is switched off for all communications.  In addition, V.8 protocol and JBIG compression are switched off automatically.	
1	Not used		Do not change the setting.	
2-3	Wrong connection prevention method		(0,1): The machine will disconnect the line without sending a fax message, if the last 8 digits of the received CSI do not match the last 8 digits of the dialed telephone number. This does not work when manually dialed.  (1,0): The same as above, except that only the last 4 digits are compared.  (1,1): The machine will disconnect the line without sending a fax message, if the other end	
	Bit 3	Bit 2		Setting
	0	0		None
	0	1		8 digit CSI
	1	0		4 digit CSI
	1	1	CSI/RTI	



		<p>does not identify itself with an RTI or CSI. (0,0): Nothing is checked; transmission will always go ahead.</p> <p><b>Note</b></p> <ul style="list-style-type: none"> <li>This function does not work when dialing is done from the external telephone.</li> </ul>		
4-5	Not used	Do not change the setting.		
6-7	Maximum printable page length available		The setting determined by these bits is informed to the transmitting terminal in the pre-message protocol exchange (in the DIS/NSF frames).	
	Bit 7	Bit 6		Setting
	0	0		No limit
	0	1		B4 (364 mm)
	1	0		A4 (297 mm)
1	1	Not used		

Communication Switch 02 (SP No. 1-104-003)		
No	Function	Comments
0	G3 Burst error threshold 0: Low 1: High	If there are more consecutive error lines in the received page than the threshold, the machine will send a negative response. The Low and High threshold values depend on the sub-scan resolution, and are as follows.
		100 dpi      6(L) →12(H)
		200 dpi      12(L) →24(H)
		300 dpi      18(L) →36(H)
		400 dpi      24(L) →48(H)
1	Acceptable total error line ratio 0: 5% 1: 10%	If the error line ratio for a page exceeds the acceptable ratio, RTN will be sent to the other end.
2	Treatment of pages received with errors during G3 reception 0: Deleted from memory without printing 1: Printed	0: Pages received with errors are not printed.
3	Hang-up decision when a negative code (RTN or PIN) is received during G3 immediate transmission 0: No hang-up, 1: Hang-up	0: The next page will be sent even if RTN or PIN is received. 1: The machine will send DCN and hang up if it receives RTN or PIN. This bit is ignored for memory transmissions or if ECM is being used.
4-7	Not used	Do not change these settings.

<b>Communication Switch 03 (SP No. 1-104-004)</b>		
<b>No</b>	<b>Function</b>	<b>Comments</b>
0-7	Maximum number of page retransmissions in a G3 memory transmission	00 - FF (Hex) times. This setting is not used if ECM is switched on. Default setting - 03(H)

<b>Communication Switch 04 (SP No. 1-104-005)</b>		
<b>No</b>	<b>Function</b>	<b>Comments</b>
0	Remote mode switch (TEL mode) 0: Disable 1: Enable (Active)	Set this bit to ON when you wish to switch TEL mode to FAX mode remotely.
1	Remote mode switch (FAX mode) 0: Disable 1: Enable (Active)	Set this bit to ON when you wish to turn on the remote mode switch after automatic reception with FAX mode.
2	Remote mode switch (AUTO mode) 0: Disable 1: Enable (Active)	Set this bit to ON when you wish to turn on the remote mode switch after automatic reception with AUTO mode.
3-7	Not used	Do not change the settings.

<b>Communication Switch 05 (SP No. 1-104-006)</b>		
<b>No</b>	<b>Function</b>	<b>Comments</b>
0-3	Remote mode switch number 00-09 (0-9:HEX)	Enter the number to switch between TEL/FAX modes using the external phone.
4-7	Not used	Do not change the settings.

<b>Communication Switch 06</b> - Not used (do not change the settings)
<b>Communication Switch 07</b> - Not used (do not change the settings)
<b>Communication Switch 08</b> - Not used (do not change the settings)

<b>Communication Switch 09 (SP No. 1-104-009)</b>		
<b>No</b>	<b>Function</b>	<b>Comments</b>
0-7	Minimum interval between automatic dialing attempts	This value is the minimum time that the machine waits before it dials the next destination.

<b>Communication Switch 0A (SP No. 1-104-011)</b>		
<b>No</b>	<b>Function</b>	<b>Comments</b>
0	Point of resumption of memory transmission upon redialing 0: From the error page 1: From page 1	0: The transmission begins from the page where transmission failed the previous time. 1: Transmission begins from the first page, using normal memory transmission.
1-7	Not used	Do not change these settings.

<b>Communication Switch 0B (SP No. 1-104-012)</b>		
<b>No</b>	<b>Function</b>	<b>Comments</b>
0-3	Not used	Do not change these settings.
4	Printout of the message when acting as a Transfer Station 0: Disabled, 1: Enabled	When the machine is acting as a Transfer Station, this bit determines whether the machine prints the fax message coming in from the Requesting Terminal.
5-7	Not used	Do not change the settings.

**Communication Switch 0C** - Not used (do not change the settings)

<b>Communication Switch 0D (SP No. 1-104-014)</b>		
<b>No</b>	<b>Function</b>	<b>Comments</b>
0-7	The available memory threshold, below which ringing detection (and therefore reception into memory) is disabled	00 to FF (Hex), unit = 4 kbytes (e.g., 06(H) = 24 kbytes) One page is about 24 kbytes. The machine refers to this setting before each fax reception. If the amount of remaining memory is below this threshold, the machine cannot receive any fax messages. If this setting is kept at 0, the machine will detect ringing signals and go into receive mode even if there is no memory available. This will result in communication failure.

<b>Communication Switch 0E (SP No. 1-104-015)</b>		
<b>No</b>	<b>Function</b>	<b>Comments</b>
0-7	Minimum interval between automatic dialing attempts	06 to FF (Hex), unit = 2 s (e.g., 06(H) = 12 s) This value is the minimum time that the machine waits before it dials the next destination.

**Communication Switch 0F** – Not used (do not change the settings.)

<b>Communication Switch 10 (SP No. 1-104-017)</b>		
<b>No</b>	<b>Function</b>	<b>Comments</b>
0-7	Memory transmission: Maximum number of dialing attempts to the same destination	01 – FE (Hex) times

**Communication Switch 11** – Not used (do not change the settings.)

<b>Communication Switch 12 (SP No. 1-104-019)</b>		
<b>No</b>	<b>Function</b>	<b>Comments</b>
0-7	Memory transmission: Interval between dialing attempts to the same destination	01 – FF (Hex) minutes

**Communication Switch 13** – Not used (do not change the settings.)

<b>Communication Switch 14 (SP No. 1-104-021)</b>				
<b>No</b>	<b>Function</b>		<b>Comments</b>	
0	Inch-to-mm conversion during transmission 0: Disabled, 1: Enabled		0: In immediate transmission, data scanned in inch format are transmitted without conversion. In memory transmission, data stored in the SAF memory in mm format are transmitted without conversion. Note: When storing the scanned data into SAF memory, the fax unit always converts the data into mm format. 1: The machine converts the scanned data or stored data in the SAF memory to the format which was specified in the set-up protocol (DIS/NSF) before transmission.	
1-5	Not used		Do not change the factory settings.	
6-7	Available unit of resolution in which fax messages are received		For the best performance, do not change the factory settings. The setting determined by these bits is informed to the transmitting terminal in the pre-message protocol exchange (in the DIS/NSF frames).	
	Bit 7	Bit 6		Unit
	0	0		mm
	0	1		inch
	1	0		mm and inch
1	1	Not used		

<b>Communication Switch 15 – Not used (do not change the settings)</b>
--

<b>Communication Switch 16 (SP No. 1-104-023)</b>		
<b>No</b>	<b>Function</b>	<b>Comments</b>
0	Not used	Do not change the settings.
1	Optional G3 unit (G3-2) 0: Not installed 1: Installed	Change this bit to 1 when installing the first optional G3 unit.
2	Not used	
3	Select PSTN connection 0: Off 1: On	This switch enables the G3-2. 0: Off, no connection 1: Recognizes and enables G3-2. This switch can be used only after G3-2 has been installed.
4-7	Not used	Do not change the settings.

<b>Communication Switch 17 (SP No. 1-104-024)</b>		
<b>No</b>	<b>Function</b>	<b>Comments</b>
0	SEP reception 0: Disabled 1: Enabled	0: Polling transmission to another maker's machine using the SEP (Selective Polling) signal is disabled.
1	SUB reception 0: Disabled 1: Enabled	0: Confidential reception to another maker's machine using the SUB (Sub-address) signal is disabled.
2	PWD reception 0: Disabled 1: Enabled	0: Disables features that require PWD (Password) signal reception.
3-4	Not used	Do not change the settings.



5	PSTN dial-in routing setting 0: OFF 1: ON	1: The machine sets multiple PSTN dial-in numbers in the PSTN dial-in line and transfers received data from each PSTN dial-in number to each address.
6	Not used	Do not change the settings.
7	Action when there is no box with an F-code that matches the received SUB code 0: Disconnect the line 1: Receive the message (using normal reception mode)	Change this setting when the customer requires.

<b>Communication Switch 18 (SP No. 1-104-025)</b>		
<b>No</b>	<b>Function</b>	<b>Comments</b>
0-4	Not used	Do not change the settings.
5	IP-Fax dial-in routing selection 0: Off 1: On	1: Transfers received data to each IP-Fax dial-in number. IP-Fax dial-in number is a 4-digit number.
6	PSTN 2 dial-in routing 0: Off 1: On	Enables or disables dial-in routing for the PSTN 2 connection.
7	PSTN 3 dial-in routing 0: Off 1: On	Enables or disables dial-in routing for the PSTN 3 connection.

**Communication Switch 19** - Not used (do not change the settings)

**Communication Switch 1A** - Not used (do not change the settings)

**FAX OPTION  
TYPE M15  
(D3B3)**

<b>Communication Switch 1B (SP No. 1-104-028)</b>		
<b>No</b>	<b>Function</b>	<b>Comments</b>
0-7	Extension access code (0 to 7) to turn V.8 protocol On/Off 0: On 1: Off	If the PABX does not support V.8/V.34 protocol procedure, set this bit to "1" to disable V.8. Example: If "0" is the PSTN access code, set bit 0 to 1. When the machine detects "0" as the first dialed number, it automatically disables V.8 protocol. (Alternatively, if "3" is the PSTN access code, set bit 3 to 1.)

<b>Communication Switch 1C (SP No. 1-104-029)</b>		
<b>No</b>	<b>Function</b>	<b>Comments</b>
0-1	Extension access code (8 and 9) to turn V.8 protocol On/Off 0: On 1: Off	Refer to communication switch 1B. Example: If "8" is the PSTN access code, set bit 0 to 1. When the machine detects "8" as the first dialed number, it automatically disables V.8 protocol. (If "9" is the PSTN access code, use bit 1.)
2-7	Not used	Do not change the settings.

<b>Communication Switch 1D - Not used (do not change the settings)</b>
<b>Communication Switch 1E - Not used (do not change the settings)</b>
<b>Communication Switch 1F - Not used (do not change the settings)</b>

## 4.6 BIT SWITCHES – 4

### ⬇ Note

- Do not adjust a bit switch or use a setting that is described as "Not used", as this may cause the machine to malfunction or to operate in a manner that is not accepted by local regulations. Such bits are for use only in other areas, such as Japan.

Default settings for bit switches are not listed in this manual. Refer to the System Parameter List printed by the machine.

### 4.6.1 G3 SWITCHES

G3 Switch 00 (SP No. 1-105-001)				
No	Function			Comments
0 1	Monitor speaker during communication (tx and rx)			(0, 0): The monitor speaker is disabled all through the communication. (0, 1): The monitor speaker is on up to phase B in the T.30 protocol. (1, 0): Used for testing. The monitor speaker is on all through the communication. Make sure that you reset these bits after testing.
	Bit 1	Bit 0	Setting	
	0	0	Disabled	
	0	1	Up to Phase B	
	1	0	All the time	
	1	1	Not used	
2	Monitor speaker during memory transmission 0: Disabled 1: Enabled			1: The monitor speaker is enabled during memory transmission.
3-5	Not used			Do not change the settings.
6	Dedicated G3 line mode selection 0: Off 1: On (Dedicated)			Set this bit to 1 when you wish to dedicate a line for G3.
7	Not used			Do not change this setting.

<b>G3 Switch 01 (SP No. 1-105-002)</b>		
<b>No</b>	<b>Function</b>	<b>Comments</b>
0-3	Not used	Do not change the settings.
4	DIS frame length 0: 10 bytes 1: 4 bytes	1: The bytes in the DIS frame after the 4th byte will not be transmitted (set to 1 if there are communication problems with PC-based faxes which cannot receive the extended DIS frames).
5	Not used	Do not change the setting.
6	Forbid CED/ANSam output 0: Off 1: On (Forbid output)	Do not change this setting (Default: 0: Off), unless communication problem is caused by a CED or ANSam transmission.
7	Not used	Do not change this setting.

<b>G3 Switch 02 (SP No. 1-105-003)</b>		
<b>No</b>	<b>Function</b>	<b>Comments</b>
0	G3 protocol mode used 0: Standard and non-standard 1: Standard only	Change this bit to 1 only when the other end can only communicate with machines that send T.30-standard frames only.  1: Disables NSF/NSS signals (these are used in non-standard mode communication)
1-6	Not used	Do not change the settings.
7	Short preamble 0: Disabled 1: Enabled	Refer to Appendix B in the Group 3 Facsimile Manual for details about Short Preamble.

<b>G3 Switch 03 (SP No. 1-105-004)</b>		
<b>No</b>	<b>Function</b>	<b>Comments</b>
0	DIS detection number (Echo countermeasure) 0: 1 1: 2	0: The machine will hang up if it receives the same DIS frame twice. 1: Before sending DCS, the machine will wait for the second DIS which is caused by echo on the line.
1	Not Used	Do not change the settings.
2	Not Used	Do not change the settings.
3	ECM frame size 0: 256 bytes 1: 64 bytes	Keep this bit at "0" in most cases.
4	CTC transmission conditions 0: After one PPR signal received 1: After four PPR signals received (ITU-T standard)	0: When using ECM in non-standard (NSF/NSS) mode, the machine sends a CTC to drop back the modem rate after receiving a PPR, if the following condition is met in communications at 14.4, 12.0, 9.6, and 7.2 kbps.  $\sqrt{N_{\text{Transmit}}} \leq N_{\text{Resend}}$ N <sub>Transmit</sub> - Number of transmitted frames N <sub>Resend</sub> - Number of frames to be retransmitted 1: When using ECM, the machine sends a CTC to drop back the modem rate after receiving four PPRs. PPR, CTC: These are ECM protocol signals. This bit is not effective in V.34 communications.
5	Modem rate used for the next page after receiving a negative code (RTN or PIN) 0: No change 1: Fallback	1: The machine's tx modem rate will fall back before sending the next page if a negative code is received. This bit is ignored if ECM is being used.
6	Not used	Do not change the settings

7	Select detection of reverse polarity in ringing 0: Off 1: On	This switch is used to prevent reverse polarity in ringing on the phone line (applied to PSTN-G3 ringing). Do not change this setting 0: No detection 1: Detection (Japan and Korea only)
---	--	---

<b>G3 Switch 04 (SP No. 1-105-005)</b>		
No	Function	Comments
0-3	Training error detection threshold	0 - F (Hex); 0 - 15 bits If the number of error bits in the received TCF is below this threshold, the machine informs the sender that training has succeeded.
4-7	Not used	Do not change the settings.

<b>G3 Switch 05 (SP No. 1-105-006)</b>						
No	Function					Comments
0-3	Initial Tx modem rate (kbps)					These bits set the initial starting modem rate for transmission. Use the dedicated transmission parameters if you need to change this for specific receivers. If a modem rate 14.4 kbps or slower is selected, V.8 protocol should be disabled manually. Cross reference V.8 protocol on/off - G3 switch 03, bit 2
	Bit 3	Bit 2	Bit 1	Bit 0	kbps	
	0	0	0	1	2.4	
	0	0	1	0	4.8	
	0	0	1	1	7.2	
	0	1	0	0	9.6	
	0	1	0	1	12.0	
	0	1	1	0	14.4	
	0	1	1	1	16.8	
	1	0	0	0	19.2	
	1	0	0	1	21.6	
	1	0	1	0	24.0	

	1	0	1	1	26.4	
	1	1	0	0	28.8	
	1	1	0	1	31.2	
	1	1	1	0	33.6	
Other settings - Not used						
4-5	Initial modem type for 9.6 k or 7.2 kbps.				These bits set the initial modem type for 9.6 and 7.2 kbps, if the initial modem rate is set at these speeds.	
	Bit 5	Bit 4	Setting			
	0	0	V.29			
	0	1	V.17			
	1	0	V.34			
	1	1	Not used			
6-7	Not used				Do not change the settings.	

G3 Switch 06 (SP No. 1-105-007)						
No	Function					Comments
0-3	Initial Rx modem rate(kbps)					These bits set the initial starting modem rate for reception. Use a lower setting if high speeds pose problems during reception. If a modem rate 14.4 kbps or slower is selected, V.8 protocol should be disabled manually. Cross reference V.8 protocol on/off - G3 switch 03, bit2
	Bit 3	Bit 2	Bit 1	Bit 0	kbps	
	0	0	0	1	2.4	
	0	0	1	0	4.8	
	0	0	1	1	7.2	
	0	1	0	0	9.6	
	0	1	0	1	12.0	
	0	1	1	0	14.4	
	0	1	1	1	16.8	
	1	0	0	0	19.2	
	1	0	0	1	21.6	

FAX OPTION  
TYPE M15  
(D3B3)

	1	0	1	0	24.0	
	1	0	1	1	26.4	
	1	1	0	0	28.8	
	1	1	0	1	31.2	
	1	1	1	0	33.6	
	Other settings - Not used					
4-7	<p>Modem types available for reception</p> <p>The setting of these bits is used to inform the transmitting terminal of the available modem type for the machine in receive mode.</p> <p>If V.34 is not selected, V.8 protocol must be disabled manually.</p> <p>Cross reference</p> <p>V.8 protocol on/off - G3 switch 03, bit 2</p>					
	Bit 7	Bit 6	Bit 5	Bit 4	Types	
	0	0	0	1	V.27ter	
	0	0	1	0	V.27ter, V.29	
	0	0	1	1	V.27ter, V.29, V.33	
	0	1	0	0	V.27ter, V.29, V.17	
	0	1	0	1	V.27ter, V.29, V.17, V.34	
Other settings - Not used						

G3 Switch 07 (SP No. 1-105-008)						
No	Function			Comments		
0-1	PSTN cable equalizer (tx mode: Internal)			Use a higher setting if there is signal loss at higher frequencies because of the length of wire between the modem and the telephone exchange.  Use the dedicated transmission parameters for specific receivers.  Also, try using the cable equalizer if one or more of the following symptoms		
	Bit 1	Bit 0	Setting			
	0	0	None			
	0	1	Low			
	1	0	Medium			



	1	1	High	<p>occurs.</p> <p>Communication error</p> <p>Modem rate fallback occurs frequently.</p> <p><b>Note</b></p> <ul style="list-style-type: none"> <li>This setting is not effective in V.34 communications.</li> </ul>
2-3	PSTN cable equalizer (rx mode: Internal)			<p>Use a higher setting if there is signal loss at higher frequencies because of the length of wire between the modem and the telephone exchange.</p> <p>Also, try using the cable equalizer if one or more of the following symptoms occurs.</p> <p>Communication error with error codes such as 0-20, 0-23, etc.</p> <p>Modem rate fallback occurs frequently.</p> <p><b>Note</b></p> <ul style="list-style-type: none"> <li>This setting is not effective in V.34 communications.</li> </ul>
	Bit 3	Bit 2	Setting	
	0	0	None	
	0	1	Low	
	1	0	Medium	
	1	1	High	
4	PSTN cable equalizer (V.8/V.17 rx mode: External) 0: Disabled 1: Enabled			Keep this bit at "1".
5	Not used			Do not change the settings.
6	Parameter selection for dial tone detection 0: Normal parameter 1: Specific parameter			<p>0: This uses the fixed table in the ROM for dial tone detection.</p> <p>1: This uses the specific parameter adjusted with SRAM (69ECBEH - 69ECDEH). Select this if the dial tone cannot be detected when the "Normal parameter: 0" is selected.</p>
7	Not used			Do not change the settings.

**G3 Switch 08** - Not used (do not change the settings)

**G3 Switch 09** - Not used (do not change the settings)

<b>G3 Switch 0A (SP No. 1-105-011)</b>				
<b>No</b>	<b>Function</b>			<b>Comments</b>
0-1	Maximum allowable carrier drop during image data reception			These bits set the acceptable modem carrier drop time.  Try a longer setting if error code 0-22 is frequent.
	Bit 1	Bit 0	Value (ms)	
	0	0	200	
	0	1	400	
	1	0	800	
	1	1	Not used	
2	Select cancellation of high-speed RX if carrier signal lost while receiving 0: Off 1: On			This switch setting determines if high-speed receiving ends if the carrier signal is lost when receiving during non-ECM mode
3	Not used			Do not change the settings
4	Maximum allowable frame interval during image data reception. 0: 5 s 1: 13 s			This bit set the maximum interval between EOL (end-of-line) signals and the maximum interval between ECM frames from the other end.  Try using a longer setting if error code 0-21 is frequent.
5	Not used			Do not change the settings.

6	Reconstruction time for the first line in receive mode 0: 6 s 1: 12 s	When the sending terminal is controlled by a computer, there may be a delay in receiving page data after the local machine accepts set-up data and sends CFR. This is outside the T.30 recommendation. But, if this delay occurs, set this bit to 1 to give the sending machine more time to send data. Refer to error code 0-20. ITU-T T.30 recommendation: The first line should come within 5 s of CFR.
7	Not used	Do not change the settings.

**G3 Switch 0B** Not used (do not change the settings).

<b>G3 Switch 0C (SP No. 1-105-013)</b>		
<b>No</b>	<b>Function</b>	<b>Comments</b>
0-1	Not used	Do not change these settings.
4-5	Select detection of DTMF/DP detection when using remote switch. 00: DTMF+PSTN (Simultaneous detection) 01: DTMF 10: DP (10 PPS) 11: DP (20 PPS)	This setting determines how to detect the signals from the handset when remote switch is active.

**G3 Switch 0D** Not used (do not change the settings).

<b>G3 Switch 0E (SP No. 1-105-015)</b>		
<b>No</b>	<b>Function</b>	<b>Comments</b>
0-7	Set CNG send time interval Some machines on the receiving side may not be able to automatically switch the 3-second CNG interval.	
	High order bit	3000-2250ms: 3000-50xNms 3000 – 50 x Nms 0F (3000 ms) <= N <= FF (2250 ms)
	Low order bit	00-0E(3000-3700ms: 3000+50xNms 3000 – 50 x Nms 0F (3000 ms) <= N <= 0F (3700 ms)

<b>G3 Switch 0F (SP No. 1-105-016)</b>		
<b>No</b>	<b>Function</b>	<b>Comments</b>
0	Alarm when an error occurred in Phase C or later 0: Disabled 1: Enabled	If the customer wants to hear an alarm after each error communication, change this bit to "1".
1	Alarm when the handset is off-hook at the end of communication 0: Disabled 1: Enabled	If the customer wants to hear an alarm if the handset is off-hook at the end of fax communication, change this bit to "1".
2-3	Not used	Do not change these settings.
4	Sidaa manual calibration setting 0: Off 1: On	1: manually calibrates for communication with a line whose current change occurs such as an optical fiber line.
5-7	Not used	Do not change the settings.

## 4.7 BIT SWITCHES – 5

### Note

- Do not adjust a bit switch or use a setting that is described as "Not used", as this may cause the machine to malfunction or to operate in a manner that is not accepted by local regulations. Such bits are for use only in other areas, such as Japan.

Default settings for bit switches are not listed in this manual. Refer to the System Parameter List printed by the machine.

### 4.7.1 IP FAX SWITCHES

IP Fax Switch 00 (SP No. 1-111-001)		
No.	Function	Comments
0	Not used	Do not change this setting.
1	IP Fax Transport 0: TCP, 1: UDP	Selects TCP or UDP protocol for IP-Fax
2	IP Fax single port selection 0: OFF, 1: ON (enable)	Selects single data port.
3	IP Fax double ports (single data port) selection 0: OFF, 1: ON (enable)	Selects whether IP-Fax uses a double port.
4	IP Fax Gatekeeper 0: OFF, 1: ON (enable)	Enables/disables the gatekeeper for IP-Fax.
5	IP Fax T30 bit signal reverse 0: LSB first, 1: MSB first	Reverses the T30 bit signal.
6	IP Fax max bit rate setting 0: Not affected, 1: Affected	When "0" is selected, the max bit rate does not affect the value of the DIS/DCS. When "1" is selected, the max bit rate affects the value of the DIS/DCS.

7	<p>IP Fax received telephone number confirmation</p> <p>0: No confirmation, 1: Confirmation</p>	<p>When "0" is selected, fax data is received without checking the telephone number.</p> <p>When "1" is selected, fax data is received only when confirming that the telephone number from the sender matches the registered telephone number in this machine. If this confirmation fails, the line is disconnected.</p>
---	---	--

IP Fax Switch 01 (SP No. 1-111-002)					
No.	Function			Comments	
0-3	<p>IP Fax delay level setting</p> <p>Selects the acceptable delay level.</p> <p>Level 0 is the highest quality</p> <p>Default is "0000" (level 0).</p>				
	Bit 3	Bit 2	Bit 1	Bit 0	
	0	0	0	0	Level 0
	0	0	0	1	Level 1
	0	0	1	0	Level 2
0	0	1	1	Level 3	
4-7	<p>IP Fax preamble wait time setting</p>			<p>Selects the preamble wait time.</p> <p>[00 to 0f]</p> <p>There are 16 values in this 4-bit binary switch combination.</p> <p>Waiting time: set value level x 100 ms</p> <p>Max: 0f (1500 ms) Min: 00 (No wait time)</p> <p>The default is "0000" (00H).</p>	

<b>IP Fax Switch 02 (SP No. 1-111-003)</b>		
<b>No.</b>	<b>Function</b>	<b>Comments</b>
0	IP Fax bit signal reverse setting 0: Maker code setting 1: Internal bit switch setting	When "0" is selected, the bit signal reverse method is decided by the maker code. When "1" is selected, the bit signal reverse method is decided by the internal bit switch. (When communicating between IP Fax devices, LSB first is selected.)
1	IP Fax transmission speed setting 0: Modem speed 1: No limitation	Selects the transmit speed for IP Fax communication.
2	SIP transport setting 0: TCP 1: UDP	This bit switch sets the transport that has priority for receiving IP Fax data. This function is activated only when the sender has both TCP and UDP.
3	CCM connection 0: No CCM connection 1: CCM connection	When "1" is selected, only the connection call message with H.323 or no tunneled H.245 is transmitted via CCM.
4	Message reception selection from non-registered SIP server 0: Answer 1: Not answer	0: This answers the INVITE message from the SIP server not registered for the machine. 1: This does not receive the INVITE message from the SIP server not registered for the machine and send a refusal message.
5	ECM communication setting 0: No limit for image compression 1: Limit for image compression	0: This does not limit the type of the image compression with ECM communication. 1: When the other end machine is Cisco, this permits the image compression other than JBIG or MMR with ECM communication.
6-7	Not used	Do not change these settings.

IP Fax Switch 03 (SP No. 1-111-004)		
No.	Function	Comments
0	Effective field limitation for G3 standard function information 0: OFF, 1: 4byte (DIS)	Limits the effective field for standard G3 function information.
1	Switching between G3 standard and G3 non standard 0: Enable switching 1: G3 standard only	Enables/disables switching between G3 standard and G3 non-standard.
2	Not used	Do not change this setting.
3	ECM frame size selection at transmitting 0: 256byte, 1: 64byte	Selects the ECM frame size for sending.
4	DIS detection times for echo prevention 0: 1 time, 1: 2 times	Sets the number of times for DIS to detect echoes.
5	CTC transmission selection 0: PPRx1 1: PPRx4	When "0" is selected, the transmission condition is decided by error frame numbers. When "1" is selected, the transmission condition is based on the ITU-T method.
6	Shift down setting at receiving negative code 0: OFF, 1: ON	Selects whether to shift down when negative codes are received.
7	Not used	Do not change this setting.

IP Fax Switch 04 (SP No. 1-111-005)		
No.	Function	Comments
0-3	TCF error threshold	Sets the TCF error threshold level. [00 to 0f] The default is "1111" (0fH).
4-7	Not used	Do not change these settings.



IP Fax Switch 05 (SP No. 1-111-006)						
No.	Function					Comments
0-3	Modem bit rate setting for transmission (kbps)					Sets the modem bit rate for transmission. The default is "0110" (14.4K bps).
	Bit 3	Bit 2	Bit 1	Bit 0	kbps	
	0	0	0	1	2.4	
	0	0	1	1	4.8	
	0	0	1	1	7.2	
	0	1	0	0	9.6	
	0	1	0	1	12.0	
	0	1	1	0	14.4	
4-5	Modem setting for transmission					Sets the modem type for transmission. The default is "00" (V29).
	Bit 5	Bit 4	Types			
	0	0	V29			
	0	1	V17			
	1	0	Not used			
	1	1	Not used			
6-7	Not used					Do not change these settings.

IP Fax Switch 06 (SP No. 1-111-007)					
No.	Function			Comments	
0-3	Modem bit rate setting for reception Sets the modem bit rate for reception. The default is "0110" (14.4K bps).				
4-7	Modem setting for reception Sets the modem type for reception. The default is "0100" (V27ter, V29, V17).				
	Bit 7	Bit 6	Bit 5	Bit 4	Types
	0	0	0	1	V.27ter
	0	0	1	0	V.27ter, V.29
	0	0	1	1	V.27ter, V.29, V.33
	0	1	0	0	V.27ter, V.29, V.17/V.33
Other settings - Not used					

IP Fax Switch 07 (SP No. 1-111-008)		
No.	Function	Comments
0	TSI information 0: Not added, 1: Added	Adds or does not add TSI information to NSS(S).
1	DCN transmission setting at T1 timeout 0: Not transmitted 1: Transmitted	Transmits or does not transmit DCN at T1 timeout.
2	Not used	Do not change this setting.
3	Hang up setting at DIS reception disabled 0: No hang up 1: Hang up after transmitting DCN	Sets whether the machine disconnects after DIS reception.
4	Number of times for training 0: 1 time, 1: 2 times	Selects the number of times training is done at the same bit rate.

5	Space CSI transmission setting at no CSI registration 0: Not transmitted 1: Transmitted	When "0" is selected, frame data is enabled. When "1" is selected, the transmitted data is all spaces.
6-7	Not used	Do not change these settings.

<b>IP Fax Switch 08 (SP No. 1-111-009)</b>				
No.	Function			Comments
0-1	T1 timer adjustment			Adjusts the T1 timer. The default is "00" (35 seconds).
	Bit 1	Bit 0		
	0	0	35 s	
	0	1	40 s	
	1	0	50 s	
	1	1	60 s	
2-3	T4 timer adjustment			Adjust the T4 timer. The default is "00" (3 seconds).
	Bit 3	Bit 2		
	0	0	3 s	
	0	1	3.5 s	
	1	0	4 s	
	1	1	5 s	
4-5	T0 timer adjustment			Adjusts the fail safe timer. This timer sets the interval between "setup" data transmission and T.38 phase decision. If your destination return is late on the network or G3 fax return is late, adjust the longer interval timer. The default is "00" (75 seconds).
	Bit 5	Bit 4		
	0	0	75 s	
	0	1	120 s	
	1	0	180 s	
	1	1	240 s	
6-7	Not used			Do not change these settings.

IP Fax Switch 09 (SP No. 1-111-010)				
No.	Function		Comments	
0	Network I/F setting for SIP connection 0: IPv4 1: IPv6.		Selects the connection type (IPV4 or IPV6) to connect to the SIP server.	
1	Network I/F setting for Fax communication 0: Same setting as SIP server connection 1: Automatic setting		0: The I/F setting for fax communication follows the setting for SIP server connection. 1: The negotiation between the SIP server and the device decides whether IPv4 or IPv6 is used for the I/F setting for fax communication.	
2	Record-route setting 0: Disable 1: Enable		0: Disables the record-route function of the SIP server. 1: Enables the record-route function of the SIP server.	
3-4	re-INVITE transmission delay timer setting		This changes the interval for transmit re-INVITE after receiving the ACK message transmitted by T.38 device.	
	Bit 4	Bit 3		
	0	0		No delay
	0	1		1 sec
	1	0		2 sec
	1	1	3 sec	
5	SIP-IPFAX: Adding vender information selection 0: Declare T38VendorInfo=RICOH 1: Not declare T38VendorInfo=RICOH		0: Use this setting normally. 1: This setting is used only when a customer wants to connect the machine with SIP server + VOIP-GW provided by AVAYA Inc.	
6-7	Not used.		Do not change these settings.	

<b>IP Fax Switch 0A</b> - Not used (do not change the settings)
<b>IP Fax Switch 0B</b> - Not used (do not change the settings)
<b>IP Fax Switch 0C</b> - Not used (do not change the settings)
<b>IP Fax Switch 0D</b> - Not used (do not change the settings)

<b>IP Fax Switch 0E (SP No. 1-111-013)</b>		
<b>No.</b>	<b>Function</b>	<b>Comments</b>
0-1	SIP: IP-FAX port mode (UDP) 00: 3 port mode 01: 2 port mode 10: 1 port mode	Switch the port mode for IP-FAX (T38 transport: UDP) at SIP call control.
2-3	SIP: IP-FAX port mode (TCP) 00: 3 port mode 01: 2 port mode 10: 1 port mode	Switch the port mode for IP-FAX (T38 transport: TCP) at SIP call control.
4-7	Not used.	Do not change these settings.

## 4.8 NCU PARAMETERS

The following tables give the RAM addresses and the parameter calculation units that the machine uses for ringing signal detection and automatic dialing. The factory settings for each country are also given. Most of these must be changed by RAM read/write (SP2-102), but some can be changed using NCU Parameter programming (SP2-103, 104 and 105); if SP2-103, 104 and 105 can be used, this will be indicated in the Remarks column. The RAM is programmed in hex code unless (BCD) is included in the Unit column.

### ↓ Note

- The following addresses describe settings for the standard NCU.

#	RAM Addr.	Function	Remarks
CC	680500	Country/Area code for NCU parameters	Use the Hex value to program the country/area code directly into this address, or use the decimal value to program it using SP2-103-001

### Country Code List

Country /Area	Decimal	Hex	Country /Area	Decimal	Hex
France	00	00	Asia	18	12
Germany	01	01	Japan	19	13
UK	02	02	Hong Kong	20	14
Italy	03	03	South Africa	21	15
Austria	04	04	Australia	22	16
Belgium	05	05	New Zealand	26	17
Denmark	06	06	Singapore	24	18
Finland	07	07	Malaysia	25	19
Ireland	08	08	China	26	1A
Norway	09	09	Taiwan	27	1B

NCU Parameters

Sweden	10	0A	Korea	28	1C
Switzerland	11	0B	Brazil	29	1D

#	RAM Addr.	Function	Unit	Remarks
01	6805B4	PSTN: Tx level from the modem	-N – 3 dBm	SP2-103-002
02	680572	Acceptable ringing signal frequency: range 1, upper limit	1000/ N (Hz).	SP2-103-003
03	680573	Acceptable ringing signal frequency: range 1, lower limit		SP2-103-004
04	680574	Acceptable ringing signal frequency: range 2, upper limit		SP2-103-005
05	680575	Acceptable ringing signal frequency: range 2, lower limit		SP2-103-006
06	680576	Number of rings until a call is detected	1	SP2-103-007 The setting must not be zero.
07	680577	Minimum required length of the first ring	20 ms	See Note B. SP2-103-008
08	680578	Minimum required length of the second and subsequent rings	20 ms	SP2-103-009
09	680579	Ringing signal detection reset time (LOW)	20 ms	SP2-103-010
10	68057A	Ringing signal detection reset time (HIGH)		SP2-103-011
11	68054A	Time between opening or closing the DO relay and opening the OHDI relay	1 ms	See Notes A, D and E. SP2-103-012
12	68054B	Break time for pulse dialing	1 ms	See Note A. SP2-103-013

13	68054C	Make time for pulse dialing	1 ms	See Note A. SP2-103-014
14	68054D	Time between final OHDI relay closure and DO relay opening or closing	1 ms	EU only. SP2-103-015 See Notes A, D and E.
15	68054E	Minimum pause between dialed digits (pulse dial mode)	20 ms	See Note A and E. SP2-103-016
16	68054F	Time waited when a pause is entered at the operation panel		SP2-103-017 See Note A.
17	680550	DTMF tone on time	1 ms	SP2-103-018
18	680551	DTMF tone off time		SP2-103-019
19	680552	Tone attenuation level of DTMF signals while dialing	-N x 0.5 -3.5 dBm	SP2-103-020 See Note C.
20	680553	Tone attenuation value difference between high frequency tone and low frequency tone in DTMF signals	-dBm x 0.5	SP2-103-021 The setting must be less than -5dBm, and should not exceed the setting at 680552h above. See Note C.
21	680554	PSTN: DTMF tone attenuation level after dialling	-N x 0.5 -3.5 dBm	SP2-103-022 See Note C.
22	680555	ISDN: DTMF tone attenuation level after dialling	-dBm x 0.5	See Note C



 Note

- A: Pulse dial parameters (addresses 68054A to 68054F) are the values for 10 pps. If 20 pps is used, the machine automatically compensates.
- B: The first ring may not be detected until 1 to 2.5 wavelengths after the time specified by this parameter.
- C: The calculated level must be between 0 and 10.  
The attenuation levels calculated from RAM data are:  
High frequency tone:
  - $0.5 \times N680552/680554 - 3.5$  dBm
  - $0.5 \times N680555$  dBmLow frequency tone:
  - $0.5 \times (N680552/680554 + N680553) - 3.5$  dBm
  - $0.5 \times (N680555 + N680553)$  dBm\*Note: N680552, for example, means the value stored in address 680552(H)
- D: 68054A: Europe - Between Ds opening and Di opening, France - Between Ds closing and Di opening  
68054D: Europe - Between Ds closing and Di closing, France - Between Ds opening and Di closing
- E: 68054A, 68054D, 68054E: The actual inter-digit pause (pulse dial mode) is the sum of the period specified by the RAM addresses 68054A, 68054D, and 68054E.

## 4.9 DEDICATED TRANSMISSION PARAMETERS

There are two sets of transmission parameters: Fax and E-mail

Each Quick Dial Key and Speed Dial Code has eight bytes of programmable parameters allocated to it. If transmissions to a particular machine often experience problems, store that terminal's fax number as a Quick Dial or Speed Dial, and adjust the parameters allocated to that number.

The programming procedure will be explained first. Then, the eight bytes will be described.

### 4.9.1 PROGRAMMING PROCEDURE

1. Set the bit 0 of System Bit Switch 00 to 1.
2. Enter Address Book Management mode ([User Tools]> System Settings> Key Operator> Address Book Management).
3. Select the address book that you want to program.
4. For the fax parameter, select "Fax Dest.", for the E-mail parameter, select "E-mail", then press "Start". Make sure that the LED of the Start button lights green.
5. The settings for the switch 00 are now displayed. Press the bit number that you wish to change.
6. To scroll through the parameter switches, either:
7. Select the next switch: press "Next" or Select the previous switch: "Prev." until the correct switch is displayed. Then go back to step 6.
8. After the setting is changed, press "OK".
9. After finishing, reset bit 0 of System Bit Switch 00 to 0.

## 4.9.2 PARAMETERS

### *Fax Parameters*

The initial settings of the following fax parameters are all FF(H) - all the parameters are disabled.

<b>Switch 00</b>
<b>FUNCTION AND COMMENTS</b>
<p>ITU-T T1 time (for PSTN G3 mode)</p> <p>If the connection time to a particular terminal is longer than the NCU parameter setting, adjust this byte. The T1 time is the value stored in this byte (in hex code), multiplied by 1 second.</p> <p><b>Range:</b> 0 to 120 s (00h to 78h)</p> <p>FFh - The local NCU parameter factory setting is used.</p> <p>Do not program a value between 79h and FEh.</p>

<b>Switch 01</b>							
No	FUNCTION					COMMENTS	
0-4	Tx level					<p>If communication with a particular remote terminal often contains errors, the signal level may be inappropriate. Adjust the Tx level for communications with that terminal until the results are better.</p> <p>If the setting is "Disabled", the NCU parameter 01 setting is used.</p> <p><b>Note</b></p> <ul style="list-style-type: none"> <li>Do not use settings other than listed on the left.</li> </ul>	
	Bit4	Bit3	Bit2	Bit1	Bit0		
	0	0	0	0	0		0
	0	0	0	0	1		-1
	0	0	0	1	0		-2
	0	0	0	1	1		-3
	0	0	1	0	0		-4
	↓	↓	↓	↓	↓		↓
	0	1	1	1	1		-15
	1	1	1	1	1		Disabled

5-7	<p>Cable equalizer</p> <p>Bit 7: 0, Bit 6: 0, Bit 5: 0 = None</p> <p>Bit 7: 0, Bit 6: 0, Bit 5: 1 = Low</p> <p>Bit 7: 0, Bit 6: 1, Bit 5: 0 = Medium</p> <p>Bit 7: 0, Bit 6: 1, Bit 5: 1 = High</p> <p>Bit 7: 1, Bit 6: 1, Bit 5: 1 = Disabled</p>	<p>Use a higher setting if there is signal loss at higher frequencies because of the length of wire between the modem and the telephone exchange when calling the number stored in this Quick/Speed Dial.</p> <p>Also, try using the cable equalizer if one or more of the following symptoms occurs.</p> <p>Communication error with error codes such as 0-20, 0-23, etc.</p> <p>Modem rate fallback occurs frequently.</p> <p><b>Note</b></p> <ul style="list-style-type: none"> <li>▪ Do not use settings other than listed on the left.</li> </ul> <p>If the setting is "Disabled", the bit switch setting is used.</p>
-----	--	---

Switch 02						
No	FUNCTION				COMMENTS	
0-3	Initial Tx modem rate				<p>If training with a particular remote terminal always takes too long, the initial modem rate may be too high. Reduce the initial Tx modem rate using these bits.</p> <p>For the settings 14.4 or kbps slower, Switch 04 bit 4 must be changed to 0.</p> <p><b>Note</b></p> <ul style="list-style-type: none"> <li>▪ Do not use settings other than listed on the left. If the setting is "Disabled", the bit switch setting is used.</li> </ul>	
	Bit3	Bit2	Bit1	Bit0		bps
	0	0	0	0		Not used
	0	0	0	1		2400
	0	0	1	0		4800
	0	0	1	1		7200
	0	1	0	0		9600
	0	1	0	1		12000
	0	1	1	0		14400
	0	1	1	1		16800
1	0	0	0	19200		

Dedicated Transmission Parameters

	1	0	0	1	21600	
	1	0	1	0	24000	
	1	0	1	1	26400	
	1	1	0	0	28800	
	1	1	0	1	31200	
	1	1	1	0	33600	
	1	1	1	1	Disabled	
	Other settings: <b>Not used</b>					
4-7	<b>Not used</b>					Do not change the settings.

Switch 03		
No	FUNCTION	COMMENTS
0-1	Inch-mm conversion before tx Bit 1: 0, Bit 0: 0 = Inch-mm conversion available Bit 1: 0, Bit 0: 1 = Inch only Bit 1: 1, Bit 0: 0 = Not used Bit 1: 1, Bit 0: 1 = Disabled	If "inch only" is selected on the machine uses inch-based resolutions for scanning, the printed copy may be slightly distorted at the other end if that machine uses mm-based resolutions. If the setting is "Inch-mm conversion available ", Inch-mm conversion become effective to the special senders. If the setting is "Disabled", the bit switch setting is used.
2-3	DIS/NSF detection method Bit 3: 0, Bit 2: 0 = First DIS or NSF Bit 3: 0, Bit 2: 1 = Second DIS or NSF Bit 3: 1, Bit 2: 0 = Not used Bit 3: 1, Bit 2: 1 = Disabled	(0, 1): Use this setting if echoes on the line are interfering with the set-up protocol at the start of transmission. The machine will then wait for the second DIS or NSF before sending DCS or NSS. If the setting is "Disabled", the bit switch setting is used.

4	V.8 protocol 0: Off 1: Disabled	If transmissions to a specific destination always end at a lower modem rate (14,400 bps or lower), disable V.8 protocol so as not to use V.34 protocol. 0: V.34 communication will not be possible. If the setting is "Disabled", the bit switch setting is used.
5	Compression modes available in transmit mode 0: MH only 1: Disabled	This bit determines the capabilities that are informed to the other terminal during transmission. If the setting is "Disabled", the bit switch setting is used.
6-7	ECM during transmission Bit 7: 0, Bit 6: 0 = Off Bit 7: 0, Bit 6: 1 = On Bit 7: 1, Bit 6: 0 = Not used Bit 7: 1, Bit 6: 1 = Disabled	For example, if ECM is switched on but is not wanted when sending to a particular terminal, use the (0, 0) setting. <b>Note</b> <ul style="list-style-type: none"> <li>▪ V.8/V.34 protocol and JBIG compression are automatically disabled if ECM is disabled.</li> <li>▪ If the setting is "Disabled", the bit switch setting is used.</li> </ul>

<b>Switch 04 - Not used</b> (do not change the settings)
<b>Switch 05 - Not used</b> (do not change the settings)
<b>Switch 06 - Not used</b> (do not change the settings)
<b>Switch 07 - Not used</b> (do not change the settings)
<b>Switch 08 - Not used</b> (do not change the settings)
<b>Switch 09 - Not used</b> (do not change the settings)

**E-mail Parameters**

The initial settings of the following e-mail parameters are all "0" (all parameters disabled).

<b>Switch 00</b>		
<b>No</b>	<b>FUNCTION</b>	<b>COMMENTS</b>
0	MH Compression mode for e-mail attachments <b>0:</b> Off <b>1:</b> On	Switches MH compression on and off for files attached to e-mails for sending.
1	MR Compression mode for e-mail attachments <b>0:</b> Off <b>1:</b> On	Switches MR compression on and off for files attached to e-mails for sending.
2	MMR Compression mode for e-mail attachments <b>0:</b> Off <b>1:</b> On	Switches MMR compression on and off for files attached to e-mails for sending.
3-6	<b>Not used</b>	Do not change these settings.
7	Designates the bits to reference for compression method of e-mail attachments <b>0:</b> Registered (Bit 0 to 6) <b>1:</b> No registration.	The "0" selection (default) references the settings for Bits 00, 01, 02 above. The "1" selection ignores the selections of Bits 00, 01, 02.

Switch 01		
No	FUNCTION	COMMENTS
0	Original width of e-mail attachment: A4 <b>0:</b> Off <b>1:</b> On	Sets the original width of the e-mail attachment as A4.
1	Original width of e-mail attachment: B4 <b>0:</b> Off <b>1:</b> On	Sets the original width of the e-mail attachment as B4.
2	Original width of e-mail attachment: A3 <b>0:</b> Off <b>1:</b> On	Sets the original width of the e-mail attachment as A3.
3-6	<b>Not used</b>	Do not change these settings.
7	Designates the bits to reference for original size of e-mail attachments <b>0:</b> Registered (Bit 0 to 6) <b>1:</b> No registration.	The "0" selection (default) references the settings for Bits 00, 01, 02 above. The "1" selection ignores the selections of Bits 00, 01, 02.



Dedicated Transmission Parameters

<b>Switch 02</b>		
<b>No</b>	<b>FUNCTION</b>	<b>COMMENTS</b>
0	Line resolution of e-mail attachment: 200 x 100 <b>0:</b> Off <b>1:</b> On	Sets the line resolution of the e-mail attachment as 200 x100.
1	Line resolution of e-mail attachment: 200 x 200 <b>0:</b> Off <b>1:</b> On	Sets the line resolution of the e-mail attachment as 200 x 200.
2	Line resolution of e-mail attachment: 200 x 400 <b>0:</b> Off <b>1:</b> On	Sets the line resolution of the e-mail attachment as 200 x 400.
3	Not used	Do not change these settings.
4	Line resolution of e-mail attachment: 400 x 400 <b>0:</b> Off <b>1:</b> On	Sets the line resolution of the e-mail attachment as 400 x 400.
5-6	<b>Not used</b>	Do not change these settings.
7	Designates the bits to reference for original size of e-mail attachments <b>0:</b> Registered (Bit 0 to 6) <b>1:</b> No registration.	The "0" selection (default) references the settings for Bits 00, 01, 02, 04 above. The "1" selection ignores the selections of Bits 00, 01, 02, 04.

**Switch 03 - Not used** (do not change the settings)

Switch 04		
No	FUNCTION	COMMENTS
0	Full mode address selection 0: Full mode address 1: No full mode (simple mode)	If the other ends have the addresses, which have the full mode function flag ("0"), this machine determines them as full mode standard machines. <ul style="list-style-type: none"> <li>▪ This machine attaches the "demand of reception confirmation" to a message when transmitting.</li> <li>▪ This machine updates the reception capability to the address book when receiving.</li> </ul>
1-7	<b>Not used</b>	Do not change these settings.

Switch 05		
No	FUNCTION	COMMENTS
0	Directr transmission selection to SMTP server 0: ON 1: OFF	Allows or does not allow the direct transmission to SMTP server.
1-7	Not used	Do not change these settings.

<b>Switch 06 - Not used</b> (do not change the settings)
<b>Switch 07 - Not used</b> (do not change the settings)
<b>Switch 08 - Not used</b> (do not change the settings)
<b>Switch 09 - Not used</b> (do not change the settings)

## 5. SPECIFICATIONS

### 5.1 GENERAL SPECIFICATIONS

#### 5.1.1 FCU

Type:	Desktop type transceiver
Circuit:	PSTN PABX
Connection:	Direct couple
Original Size:	Book (Face down): Maximum Width: 216 mm [8.5 inch] ARDF (Face up): (Single-sided document) Length: 139 - 1200 mm [5.5 - 47.2 inch] Width: 139 - 216 mm [5.5 - 8.5 inch] (Double-sided document) Length: 160 - 356 mm [6.3 - 14.0 inch] Width: 139 - 216 mm [5.5 - 8.5 inch]
Scanning Method:	Flat bed, with CCD
Resolution:	G3: 8 x 3.85 lines/mm, 200 x 100 dpi (Standard character), 8 x 7.7 lines/mm, 200 x 200 dpi (Detail character),
Transmission Time:	G3: 3 s at 28800 bps; Measured with G3 ECM using memory for an ITU-T #1 test document (Slerexe letter) at standard resolution
Data Compression:	MH, MR, MMR, JBIG
Protocol:	Group 3 with ECM
Modulation:	V.34, V.17 (TCM), V.29, V.17 (QAM), V.27ter (PHM), V.8, V.21 (FSK)

Data Rate:	G3: 33600/31200/28800/26400/24000/21600/ 19200/16800/14400/12000/9600/7200/4800/2400 bps Automatic fallback
I/O Rate:	With ECM: 0 ms/line Without ECM: 2.5, 5, 10, 20, or 40 ms/line
Memory Capacity:	ECM: 128 KB SAF: 4MB

### 5.1.2 CAPABILITIES OF PROGRAMMABLE ITEMS

The following table shows the capabilities of each programmable items.

Item	Standard
Quick Dial	2000
Groups	100
Destination per Group	500
Programs	100
Communication records for Journal stored in the memory	200
Specific Senders	250

#### Note

- Measured using an ITU-T #1 test document (Slerexe letter) at the standard resolution, the auto image density mode and the Text mode.

## 5.2 IFAX SPECIFICATIONS

<b>Connectivity:</b>	Local area network Ethernet 1000 Base-T/ 100base-Tx/ 10base-T IEEE802.11a/g/n (wireless LAN)
<b>Resolution:</b>	Main scan: 200 dpi Sub scan: 200 dpi, 100 dpi
<b>Transmission Time:</b>	1 s (through a LAN to the server) Condition: ITU-T #1 test document (Selerexe Letter) MTF correction: OFF TTI: None Resolution: 200 x 100 dpi Communication speed: 10 Mbps Correspondent device: E-mail server Line conditions: No terminal access
<b>Document Size:</b>	Maximum message width is A4/LT.
<b>E-mail File Format:</b>	Single/multi-part MIME conversion Image: TIFF-F (MH, MR, MMR)
<b>Protocol:</b>	<b>Transmission:</b> SMTP, TCP/IP <b>Reception:</b> POP3, SMTP, IMAP4, TCP/IP
<b>Data Rate:</b>	1000Mbps (1000 Base-T) 100 Mbps (100base-Tx) 10 Mbps (10base-T)
<b>Authentication Method:</b>	SMTP-AUTH POP before SMTP A-POP
<b>Remark:</b>	The machine must be set up as an e-mail client before installation. Any client PCs connected to the machine through a LAN must also be e-mail clients, or some features will not work (e.g. Autorouting).

## 5.3 IP-FAX SPECIFICATIONS

Network:	Local Area Network Ethernet/10base-T, 100base-TX IEEE802.11a/g/n (wireless LAN), 1000 Base-T
Scan line density:	8 x 3.85 lines/mm, 200x100dpi (standard character), 8 x 7.7lines/mm, 200x200dpi (detail character),
Original size:	A4
Maximum scanning size:	A4, 216 x 356 mm, Irregular, 216 x 1200 mm
Transmission protocol:	Recommendation: T.38, TCP, UDP/IP communication, SIP (RFC 3261 compliant), H.323 v2
Compatible machines:	IP-Fax compatible machines
IP-Fax transmission function:	Specify IP address and send fax to an IP-Fax compatible fax through a network. Also capable of sending fax from a G3 fax connected to the public telephone lines via a VoIP gateway.
IP-Fax reception function:	Receive a fax sent from an IP-Fax compatible fax through a network. Also capable of receiving fax from a G3 fax connected the public telephone lines via a VoIP gateway.

## 5.4 FAX UNIT CONFIGURATION

Component	Code	Remarks
FCU	D3B3	Included with the fax unit
Speaker		
Fax Connection Unit Type M15	D3B4	This is used to set up the remote fax function.

**D794**

**PAPER FEED UNIT PB1090**

<b>REVISION HISTORY</b>		
<b>Page</b>	<b>Date</b>	<b>Added/Updated/New</b>
		None





# PAPER FEED UNIT PB1090 (D794)

## TABLE OF CONTENTS

<b>1. REPLACEMENT AND ADJUSTMENT.....</b>	<b>1</b>
1.1 COVERS AND ROLLERS.....	1
1.1.1 PAPER TRAY .....	1
1.1.2 REAR COVER.....	2
1.1.3 PICK-UP ROLLER.....	3
1.1.4 PAPER FEED ROLLER .....	3
1.1.5 FRICTION ROLLER.....	5
1.1.6 VERTICAL TRANSFER ROLLER .....	7
1.2 MOTORS AND CLUTCH .....	10
1.2.1 TRAY LIFT MOTOR.....	10
1.2.2 PAPER FEED MOTOR.....	11
1.2.3 PAPER FEED CLUTCH .....	13
1.3 SENSORS AND BOARD .....	15
1.3.1 PAPER END SENSOR.....	15
1.3.2 TRAY LIFT SENSOR.....	17
1.3.3 PAPER FEED SENSOR.....	19
1.3.4 TRAY SET SWITCH.....	20
1.3.5 RIGHT DOOR SWITCH .....	21
1.3.6 MAIN BOARD.....	23
<b>2. DETAILED DESCRIPTIONS .....</b>	<b>24</b>
2.1 MECHANISMS.....	24
2.1.1 OVERVIEW .....	24
2.1.2 PAPER FEED AND SEPARATION.....	25
2.1.3 PAPER LIFT MECHANISM .....	26
2.1.4 PAPER END DETECTION.....	28
2.1.5 SIDE FENCES.....	29







# READ THIS FIRST

## Symbols and Abbreviations

### Conventions Used in this Manual

This manual uses several symbols.

Symbol	What it means
	Screw
	Connector
	E-ring
	Clip ring
	Clamp

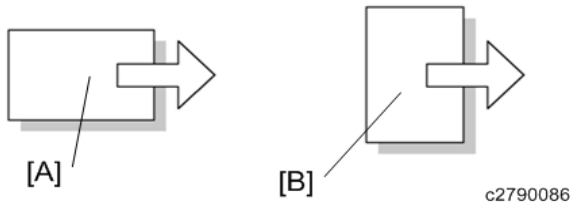

[A]: Short Edge Feed (SEF)

[B]: Long Edge Feed (LEF)

### Cautions, Notes, etc.

The following headings provide special information:

#### **WARNING**

- Failure to obey warning information could result in serious injury or death.

#### **CAUTION**

- Obey these guidelines to ensure safe operation and prevent minor injuries.

#### **Important**

- **Obey these guidelines to avoid problems such as misfeeds, damage to originals, loss of valuable data and to prevent damage to the machine.**
- **Always obey these guidelines to avoid serious problems such as misfeeds, damage to originals, loss of valuable data and to prevent damage to the machine. bold is added for emphasis.**

#### **Note**

- This document provides tips and advice about how to best service the machine.



---

# 1. REPLACEMENT AND ADJUSTMENT

## 1.1 COVERS AND ROLLERS

### 1.1.1 PAPER TRAY

1. Pull out the paper tray [A].

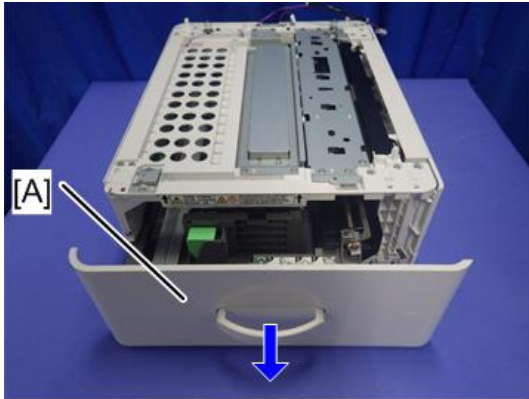

d794z0001

PAPER FEED  
UNIT PB1090  
(D794)

## 1.1.2 REAR COVER

### 1. Two screw covers [A]

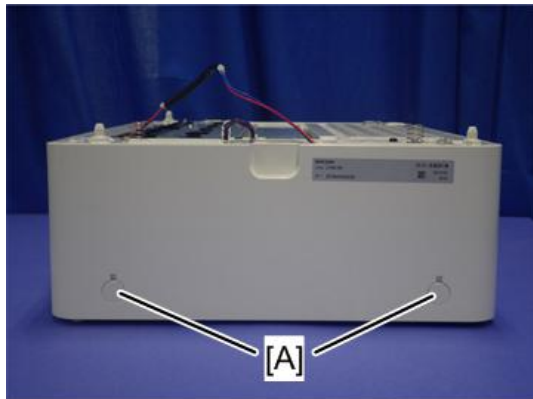

d794z0002

### 2. Rear cover [A]

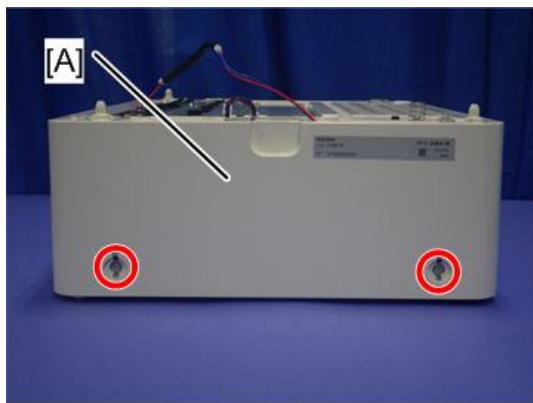

 x2

d794z0003

### 1.1.3 PICK-UP ROLLER

1. Paper tray (page 1)
2. Pick-up roller [A]

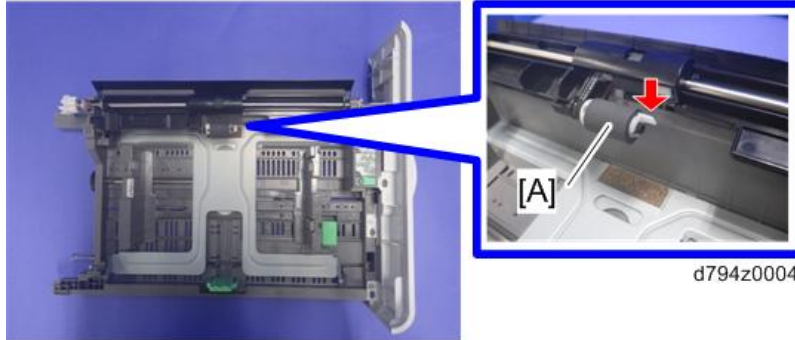



 x1

PAPER FEED  
UNIT PB1090  
(D794)

### 1.1.4 PAPER FEED ROLLER

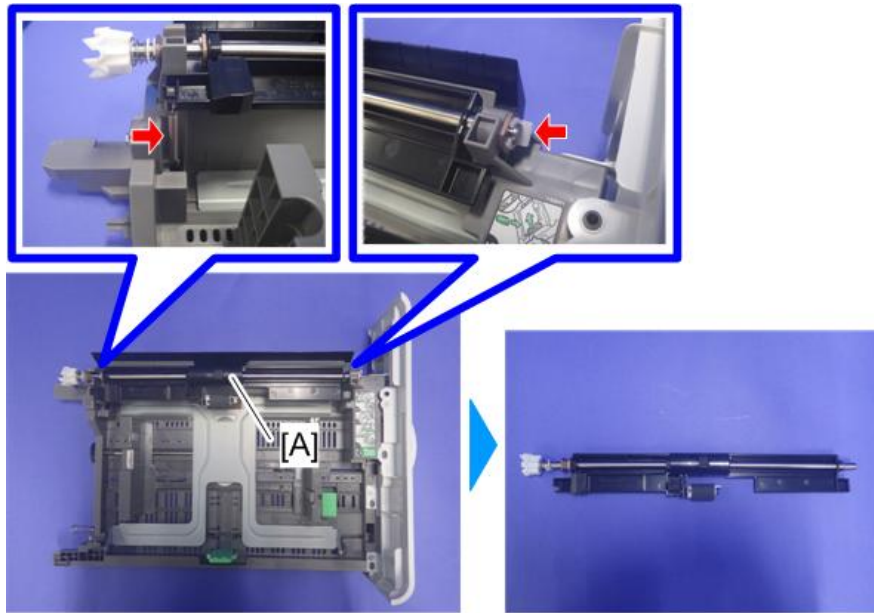
1. Pick-up roller (page 3)
2. Paper feed roller unit [A]



 x1,  x1



3. Bearing [A]

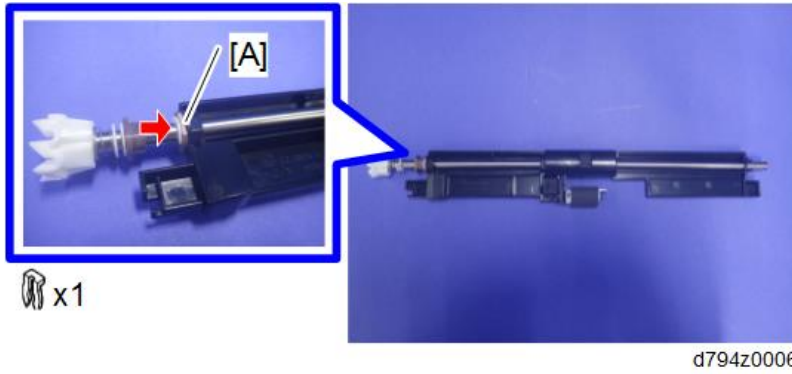

4. Pull out the shaft [A], and then remove the paper feed roller [B].

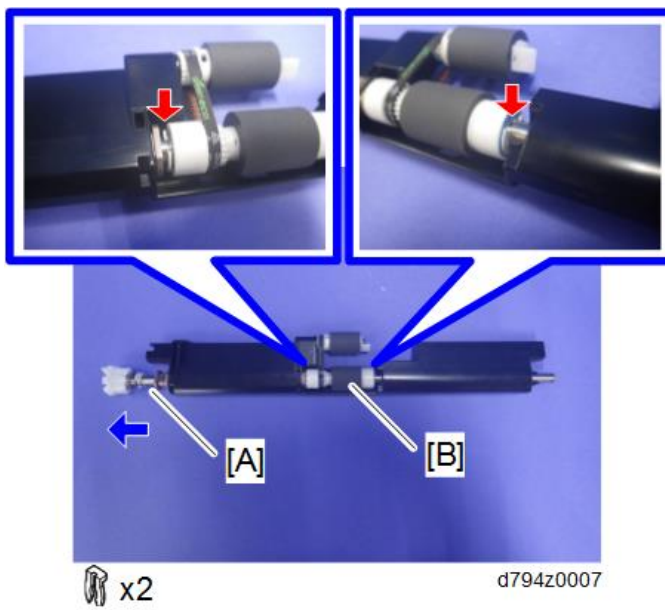

## 1.1.5 FRICTION ROLLER

1. Paper tray (page 1)
2. Paper feed guide [A]

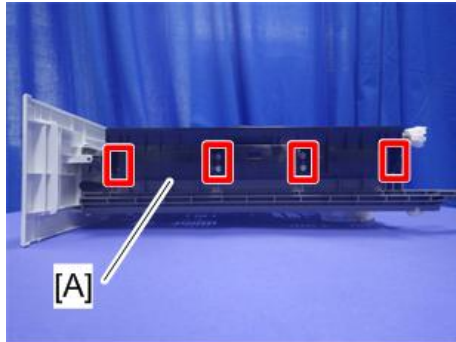

 x8



d794z0008

PAPER FEED  
UNIT PB1090  
(D794)

3. Remove the clamp from paper feed guide.



 x1

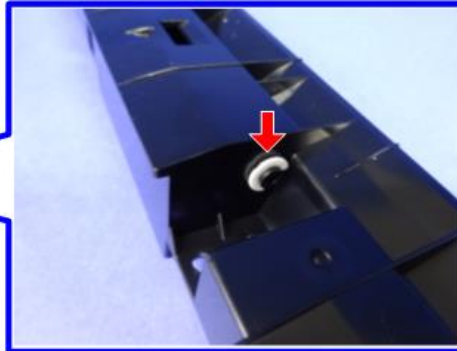

d794z0058

4. Friction roller bracket [A]

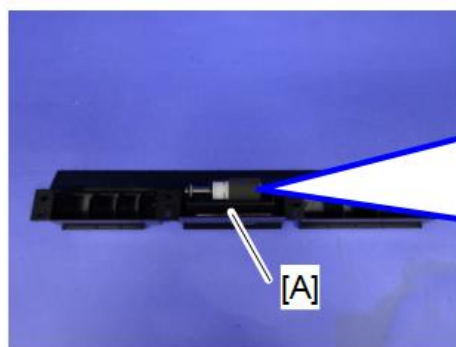

d794z0059

### Note

- There is a spring [A] under the friction roller bracket. Be careful not to lose it because it is not fixed.

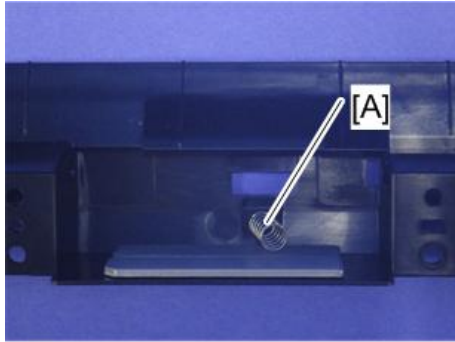

d794z0010

5. Friction roller [A] and torque limiter [B]

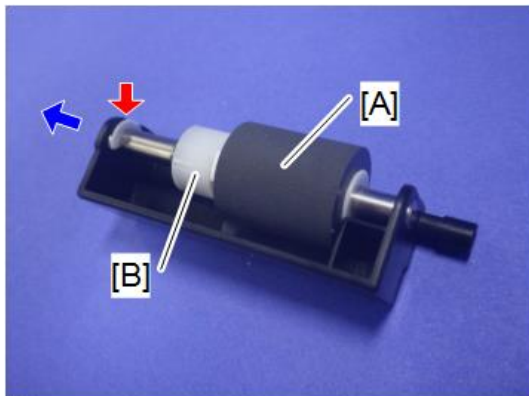

 x1

d794a0001

### 1.1.6 VERTICAL TRANSFER ROLLER

1. Paper tray (page 1)
2. Rear cover (page 2)
3. Main board cover [A]

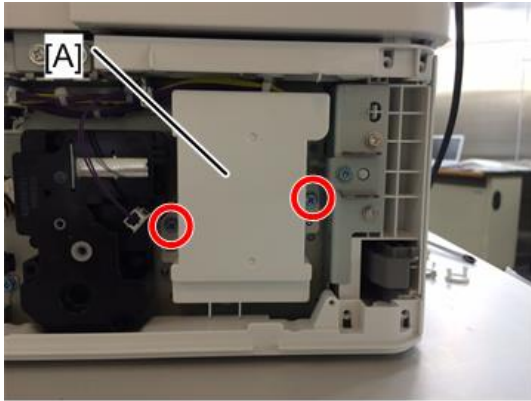

 x2 d794a0002

4. Release the harness [A] of the vertical transfer unit.

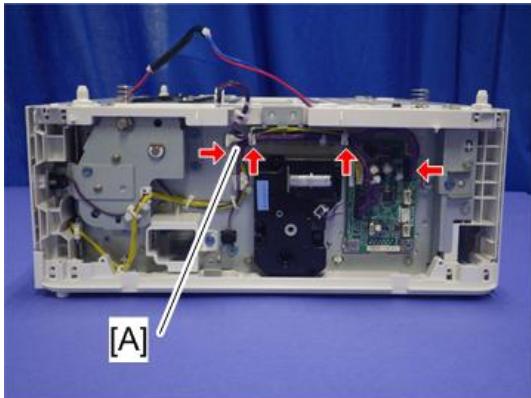

 x3,  x1 d794z0012

5. Open the right door [A].

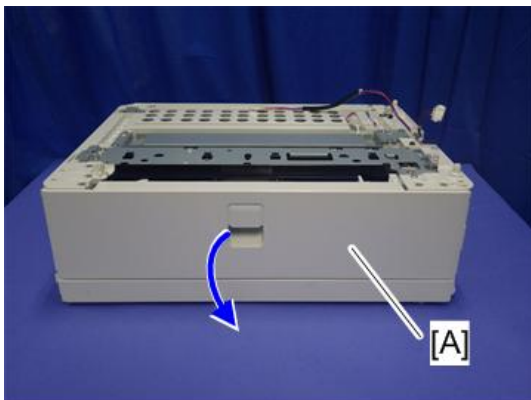

d794z0013

### 6. Tray heater [A] (If it is installed)

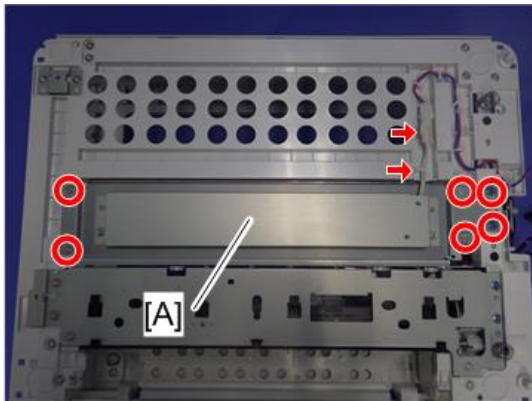

x2: 3x6, x4: 3x10 d794a0003  
 x1, x1

#### ↓ Note

- 3x6 screws are used on the rear cover side.

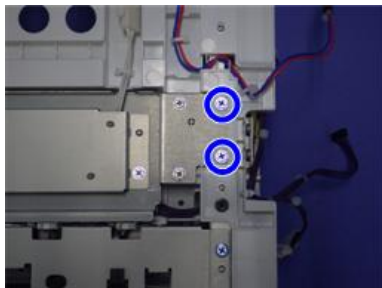

d794z0015

### 7. Vertical transfer roller unit [A]

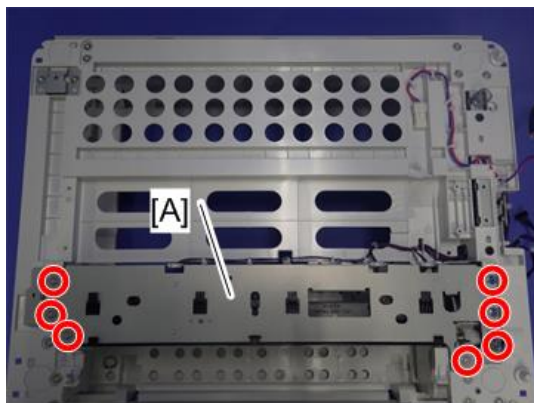

x3: 3x6, x4: 3x10 d794a0004

#### ↓ Note

- 3x6 screws are used on the rear cover side. One of them at the front side (indicated by the arrow in the diagram) is enclosed by a spring.

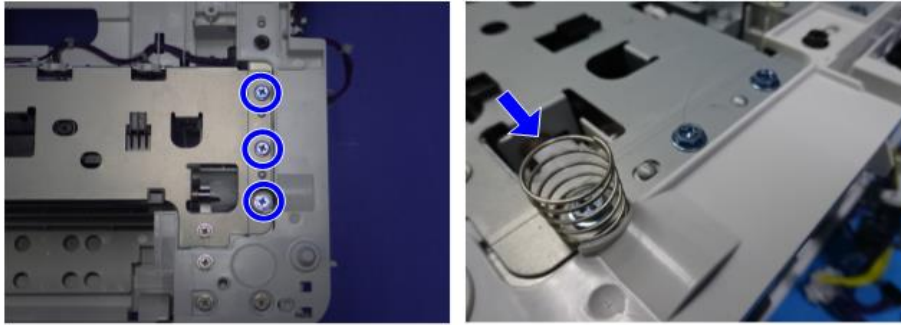

d794z0017

## 8. Vertical transfer roller cover [A]

### ↓ Note

- Slide the hooks [C] with the buttons [B] held pressed, and then release the hook [D] to remove the guide plate [E] from the vertical transfer roller cover [A].

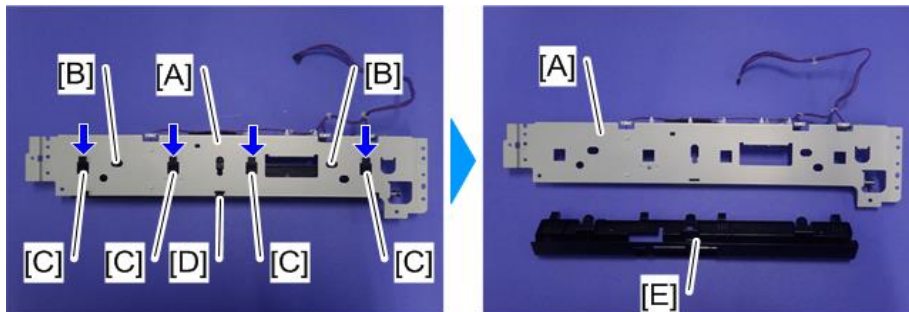

d794a0005

## 9. Do the following:

- Turn the vertical transfer roller unit [A] upside down.
- Remove the Vertical transfer roller [B] (⌀ x 1)

### ↓ Note

- Slide the vertical transfer roller axis, and then pull out the vertical transfer roller [B] from the bracket by aligning the pin [C] with the slot [D] in the bracket.

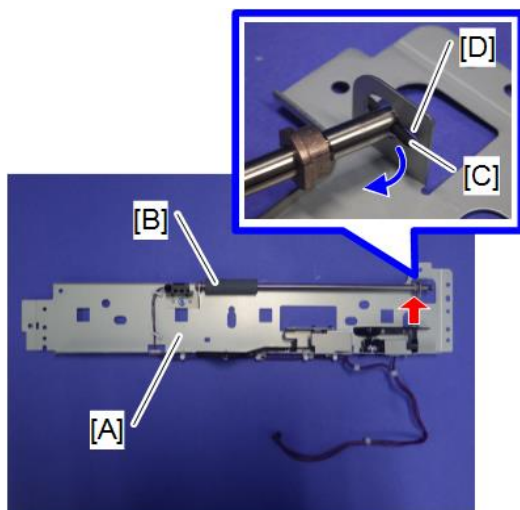

⌀ x1

d794z0019



## 1.2 MOTORS AND CLUTCH

### ★ Important

- Unplug the machine power cord before starting the following procedures.

### 1.2.1 TRAY LIFT MOTOR

1. Paper tray (page 1)
2. Rear cover (page 2)
3. Tray lift motor [A]

In the tray

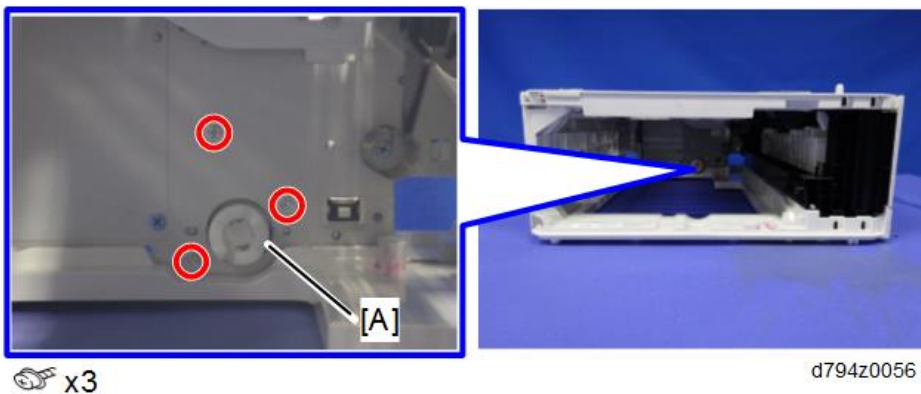

From the rear

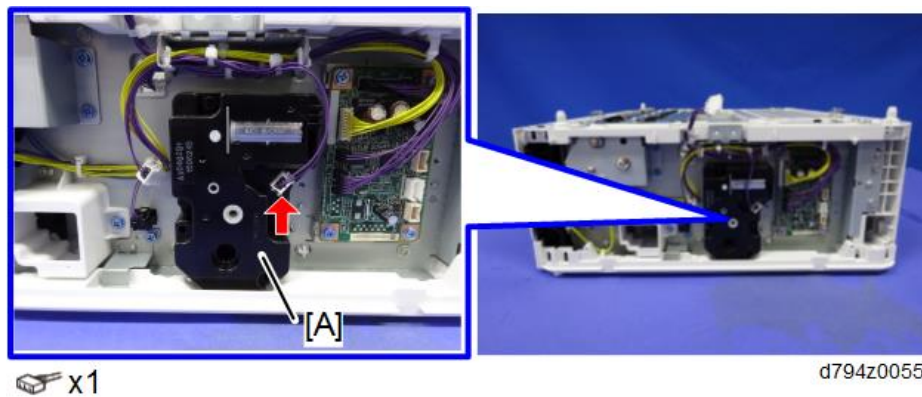

### 1.2.2 PAPER FEED MOTOR

- 1. Open the right door [A].

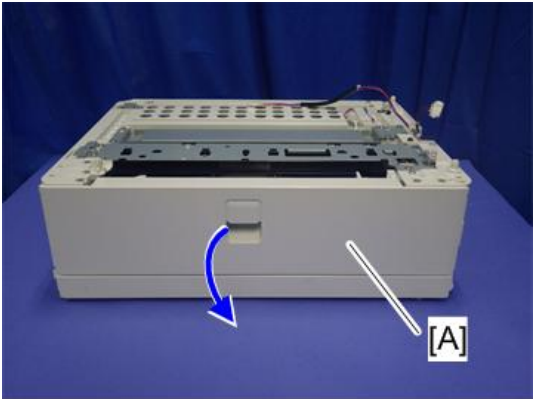

d794z0013

PAPER FEED  
UNIT PB1090  
(D794)

- 2. Stoppers [A]

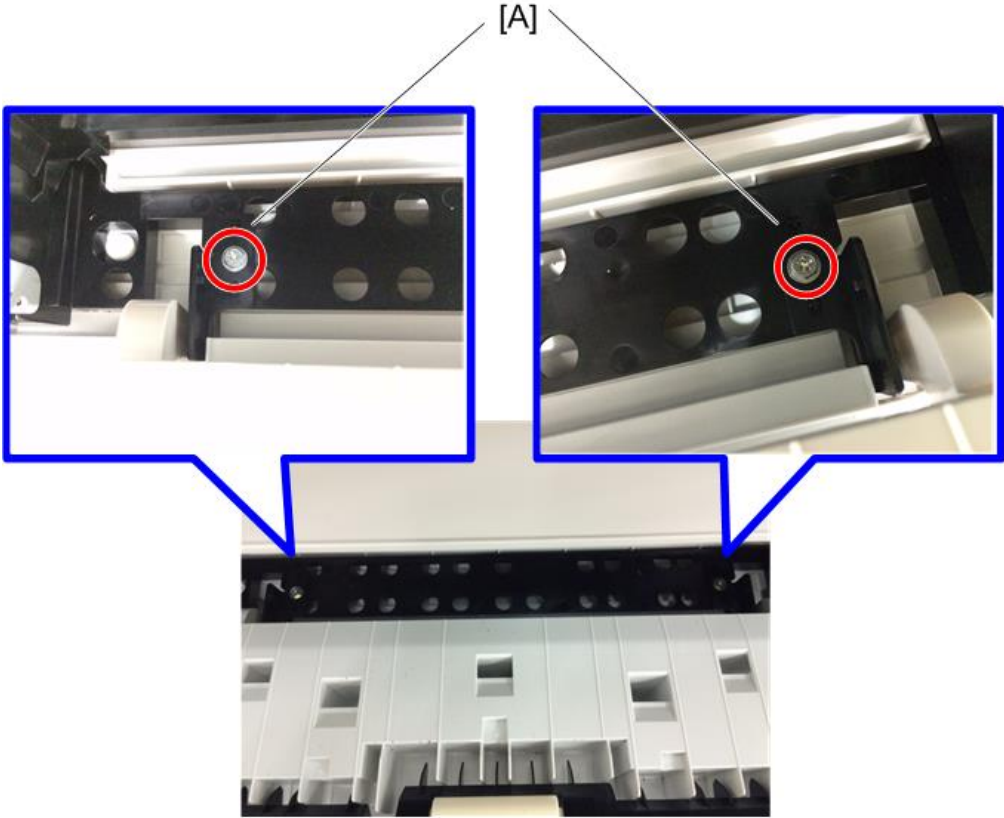

Key x2

d794a0006



3. Right door [A]

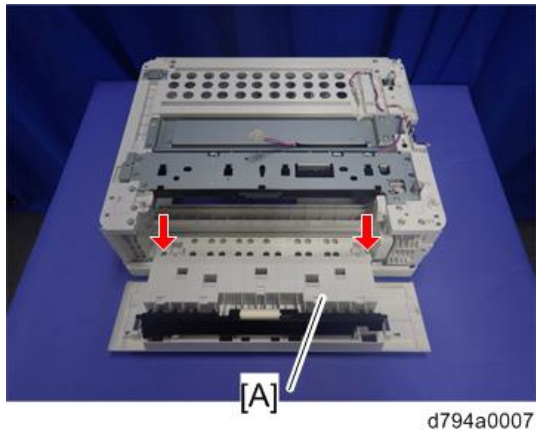

4. Right door bracket [A]

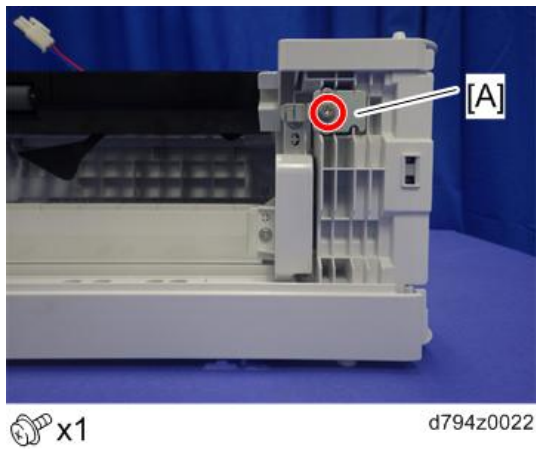

5. Paper feed motor cover [A]

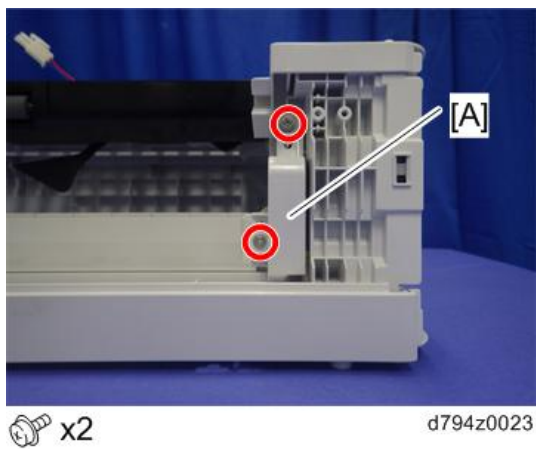

6. Paper feed motor [A]

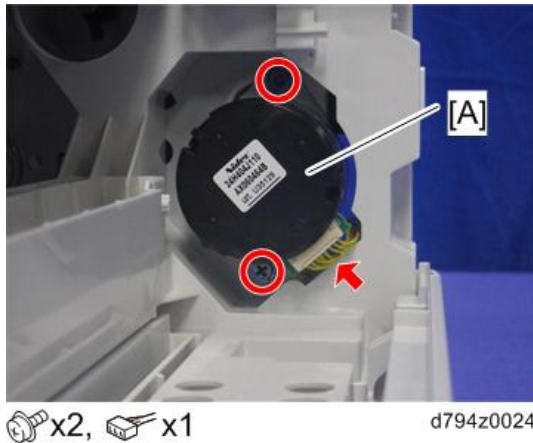

1.2.3 PAPER FEED CLUTCH

1. Rear cover (page 2)
2. Right door switch bracket (page 21)
3. Gear cover [A]

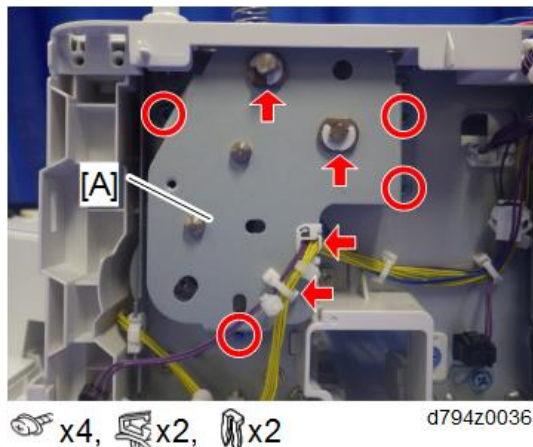

4. Gear [A]

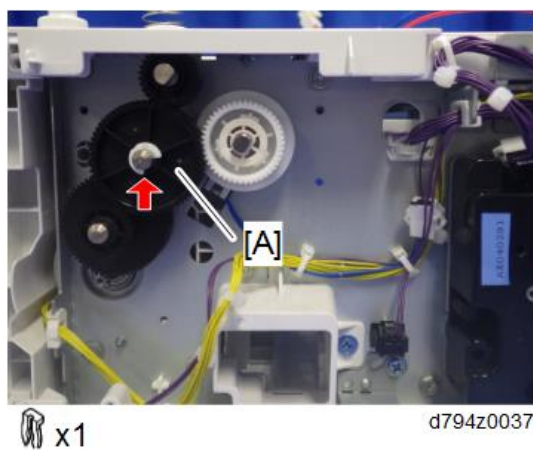

5. Paper feed clutch [A]

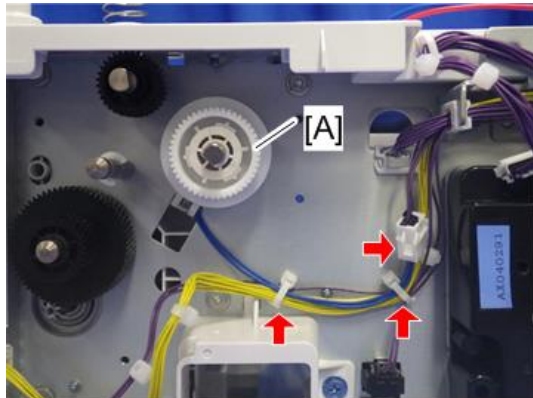

 x2,  x1

d794z0038

## 1.3 SENSORS AND BOARD

### ★ Important

- Unplug the machine power cord before starting the following procedure.

### 1.3.1 PAPER END SENSOR

1. Vertical transfer roller cover (page 7)
2. Bracket [A]

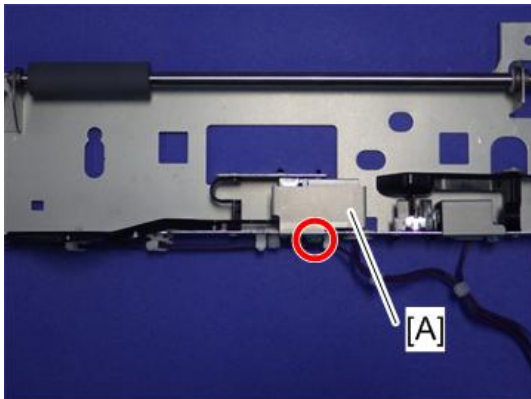

🔑 x1

d794z0025

3. Paper end feeler [A]

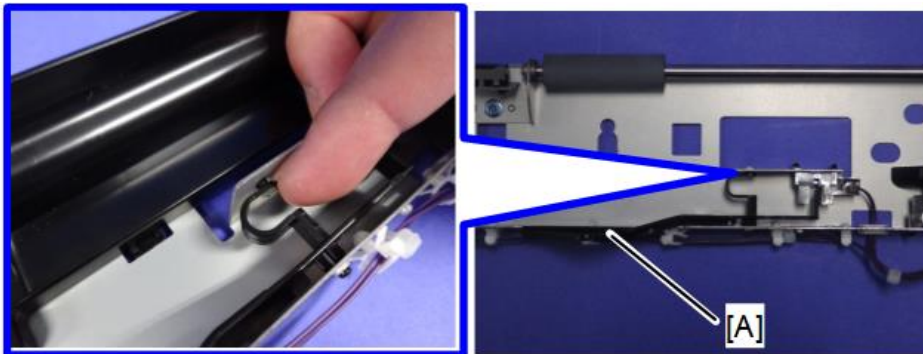

d794z0026

4. Paper end sensor [A]

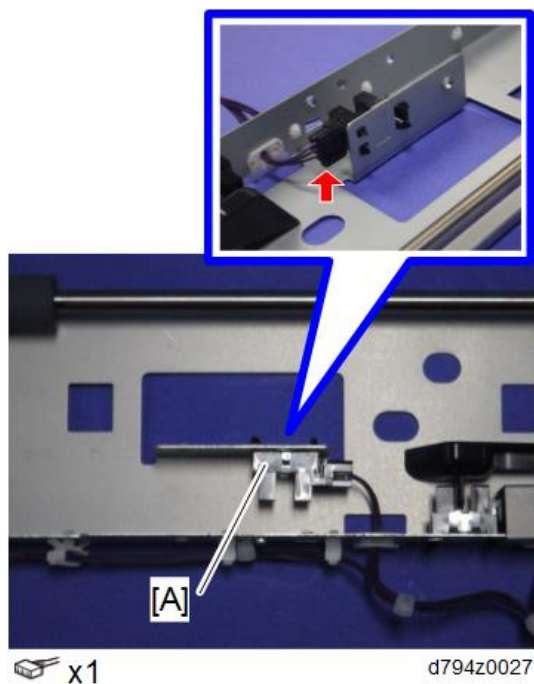

### 1.3.2 TRAY LIFT SENSOR

1. Vertical transfer roller cover (page 7)
2. Bracket [A]

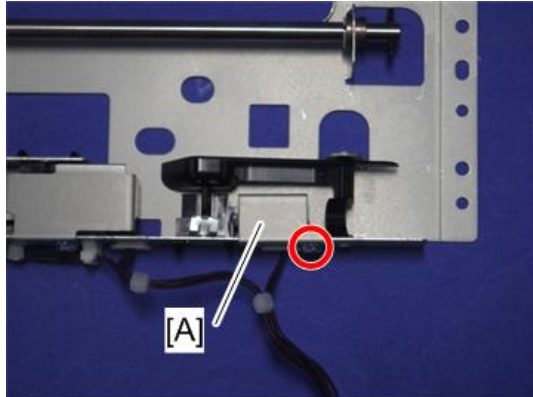

 x1

d794z0028

3. Tray lift feeler [A]

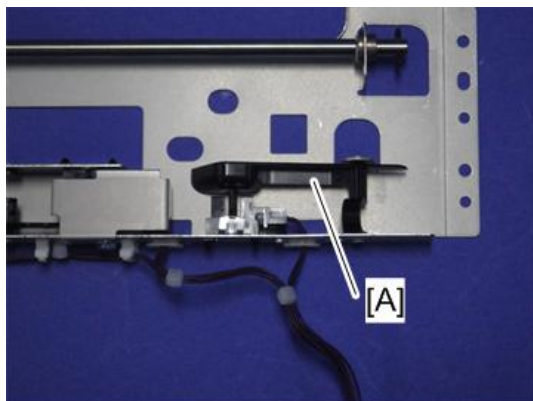

d794z0029

PAPER FEED  
UNIT PB1090  
(D794)

4. Tray lift sensor [A]

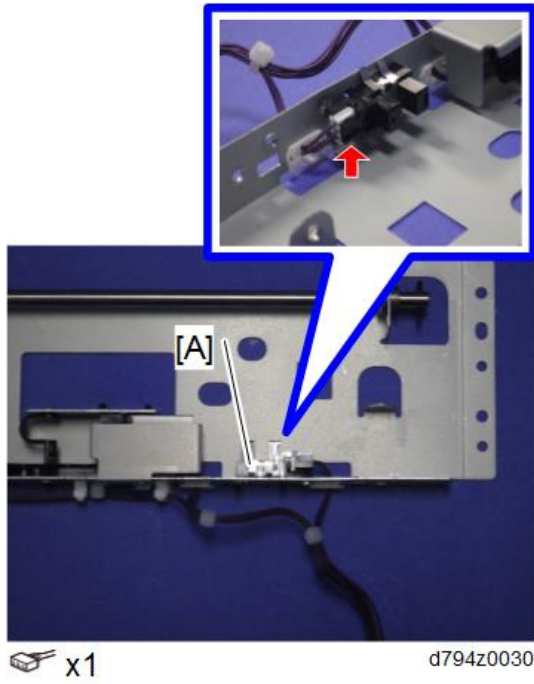

5. Sensor protector [A]

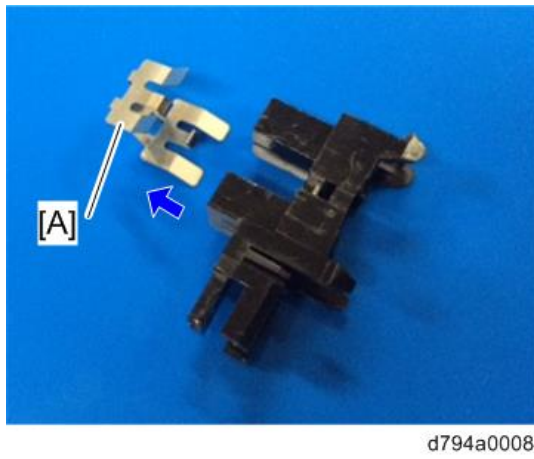

### 1.3.3 PAPER FEED SENSOR

1. Vertical transfer roller cover (page 7)
2. Paper feed sensor [A]

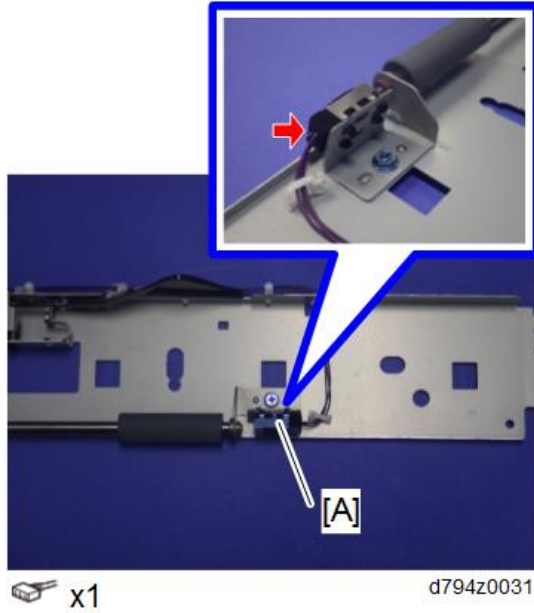

3. Sensor protector [A]

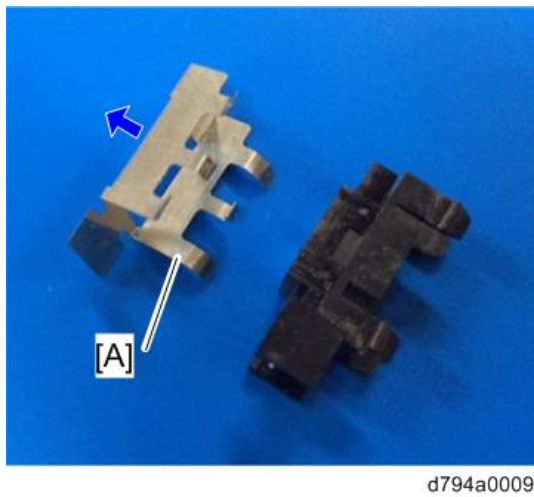

PAPER FEED  
UNIT PB1090  
(D794)



### 1.3.4 TRAY SET SWITCH

1. Paper tray (page 1)
2. Rear cover (page 2)
3. Tray set switch harness [A]

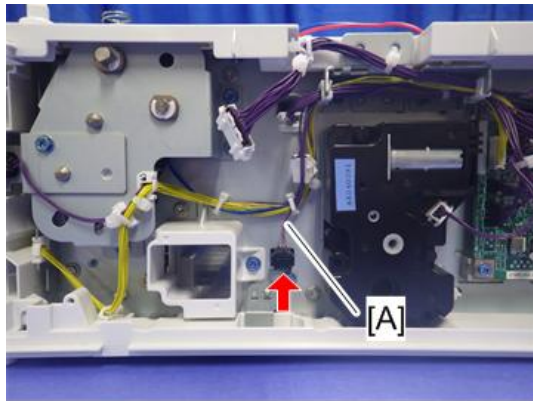

 x1

d794z0032

4. Tray set switch [A]

 Note

- Pull it out from the inside of the mainframe.

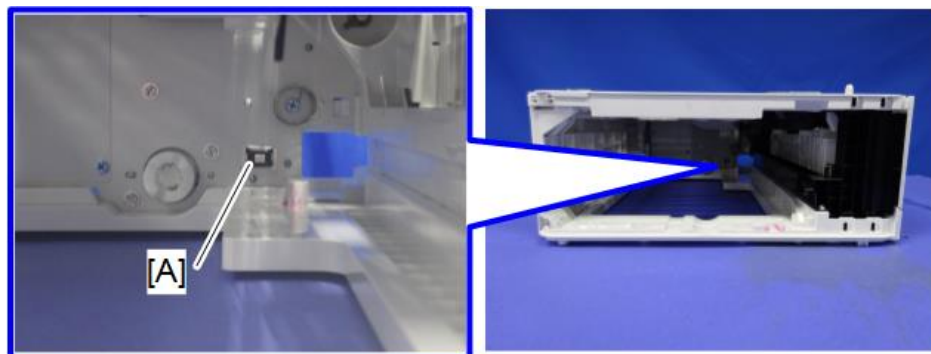

d794z0033

5. Sensor protector [A]

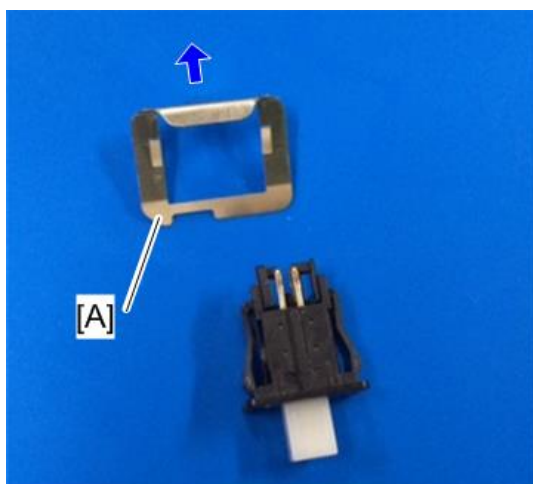

d794a0010

### 1.3.5 RIGHT DOOR SWITCH

1. Rear cover (page 2)
2. Open the right door [A].

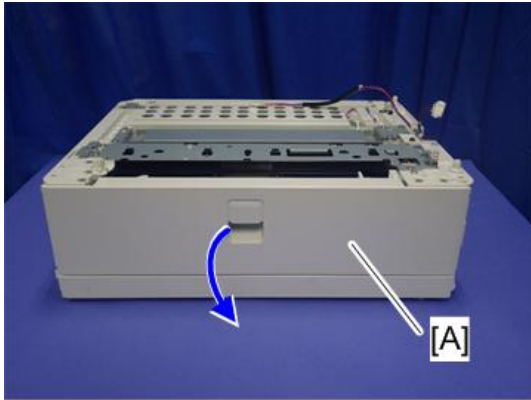

d794z0013

3. Right door switch bracket [A]

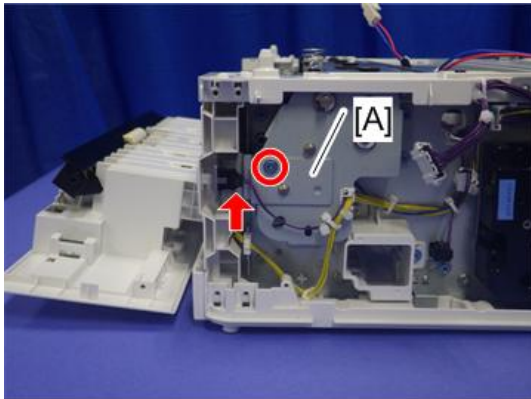

 x1,  x1

d794z0034

4. Right door switch [A]

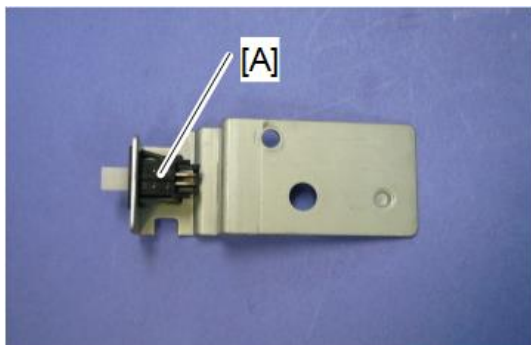

d794z0057

5. Sensor protector [A]

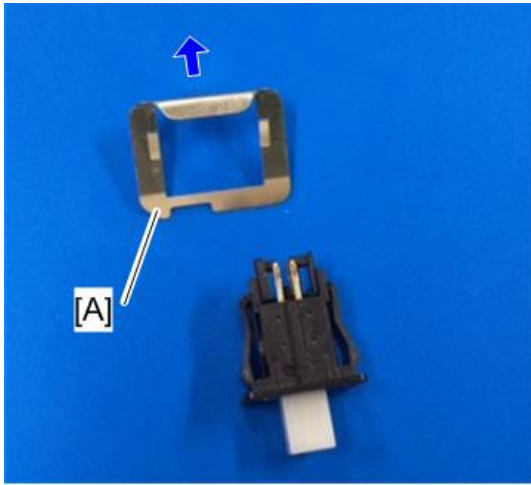

d794a0010

### 1.3.6 MAIN BOARD

1. Rear cover (page 2)
2. Main board cover

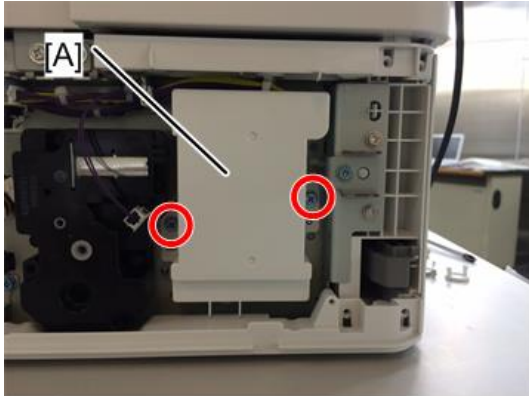

 x2

d794a0002

3. Main board [A]

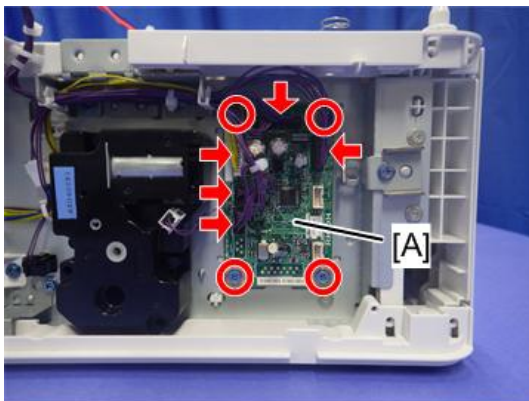

 x4,  x5

d794z0039

PAPER FEED  
UNIT PB1090  
(D794)

## 2. DETAILED DESCRIPTIONS

### 2.1 MECHANISMS

#### 2.1.1 OVERVIEW

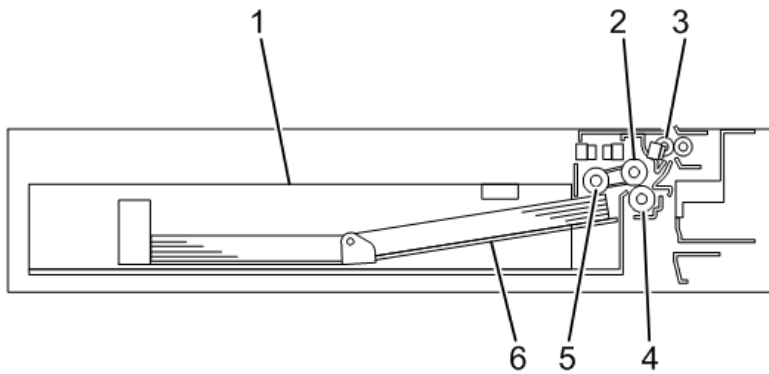

d245k9049

1	Paper feed tray	4	Friction roller
2	Paper feed roller	5	Pick-up roller
3	Vertical transfer roller	6	Tray bottom plate

## 2.1.2 PAPER FEED AND SEPARATION

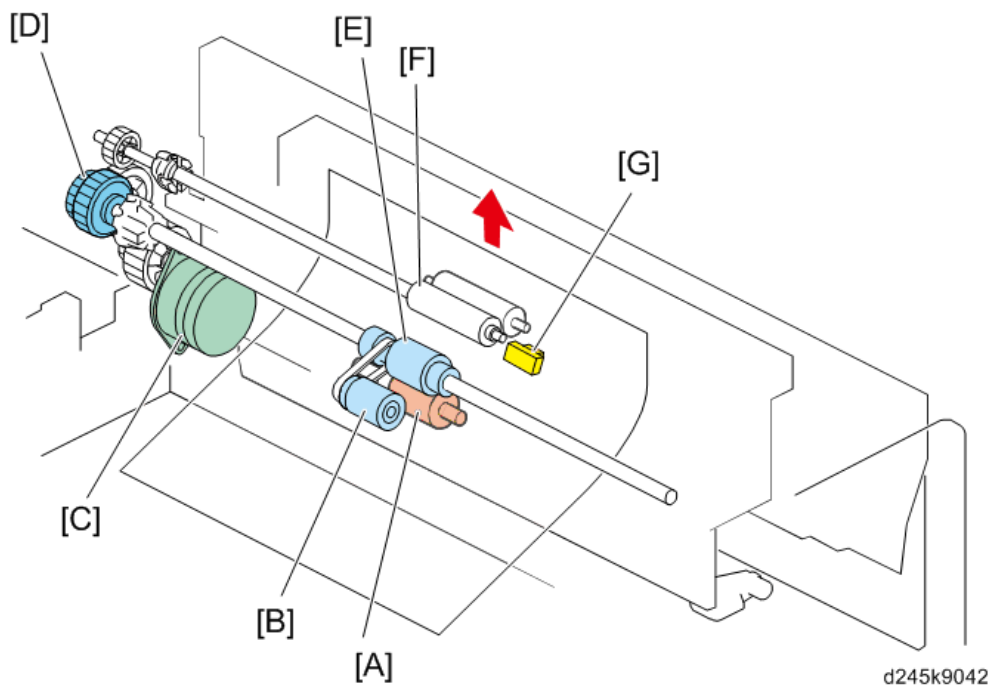

PAPER FEED  
UNIT PB1090  
(D794)

The paper feed unit employs an RF system.

In a conventional FRR system, double feed of paper is prevented by reverse rotation of the separating roller. However, paper separation of the RF system is assisted by the resistance of a friction roller [A] with a torque limiter (reverse drive is not performed).

When the paper feed tray is set in the machine, the tray bottom plate is lifted up, and the pick-up roller [B] contacts the top of the stuck paper.

When the transport motor [C] and the paper feed clutch [D] is switched ON, the rollers rotate, and then paper is supplied to the mainframe by the paper feed roller [E] and vertical transport roller [F]. The paper feed sensor [G] detects the leading edge and trailing edge of paper to control the feed timing and determine a paper jam.

The roller holder functions as a paper guide and roller clip ring. The roller holder prevents the paper from winding up.

### 2.1.3 PAPER LIFT MECHANISM

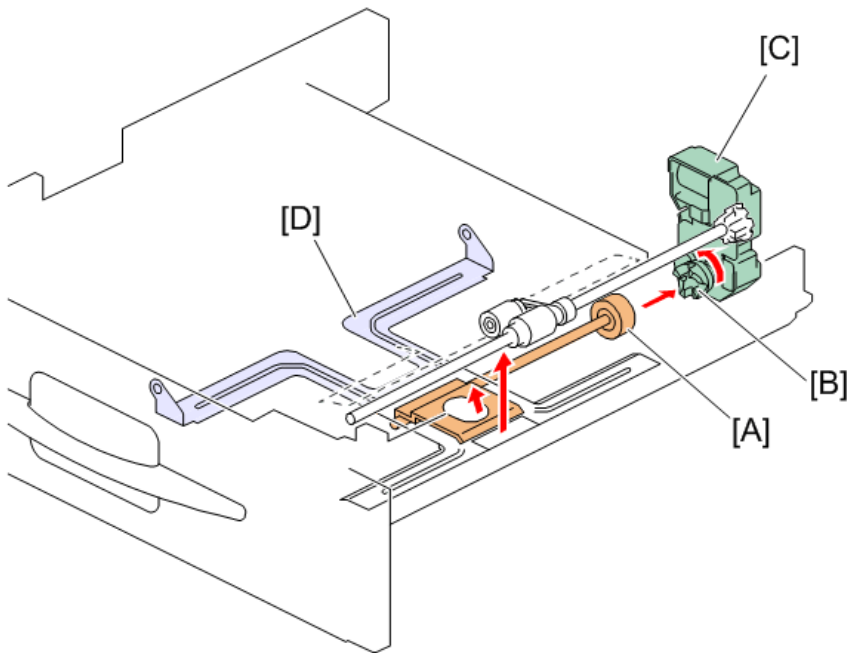

d245k9044

When the paper feed tray is set in the machine, the set switch at the rear of the tray switches ON, and it is detected that the tray is set.

The coupling [B] between the shaft [A] at the rear of the tray and the lift motor [C] then engages, the motor rotates, and the tray bottom plate [D] is lifted.

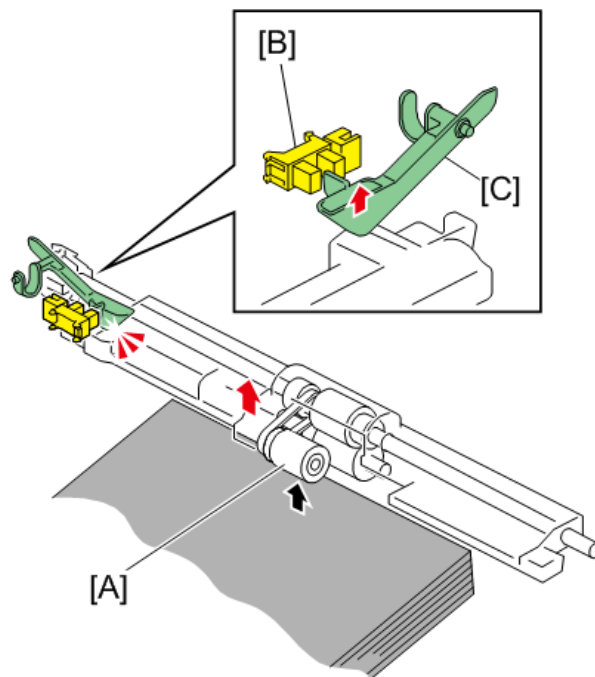

d245k9045

The tray bottom plate lifts until the paper surface pushes up the pick-up roller [A], the tray lift sensor [B] switches OFF (interrupt) by the tray lift feeler [C], and the machine enters the paper feed standby mode.

When the tray is removed, the coupling is released, and the tray bottom plate moves down. The lift motor then rotates until the coupling returns to the home position.

PAPER FEED  
UNIT PB1090  
(D794)



## 2.1.4 PAPER END DETECTION

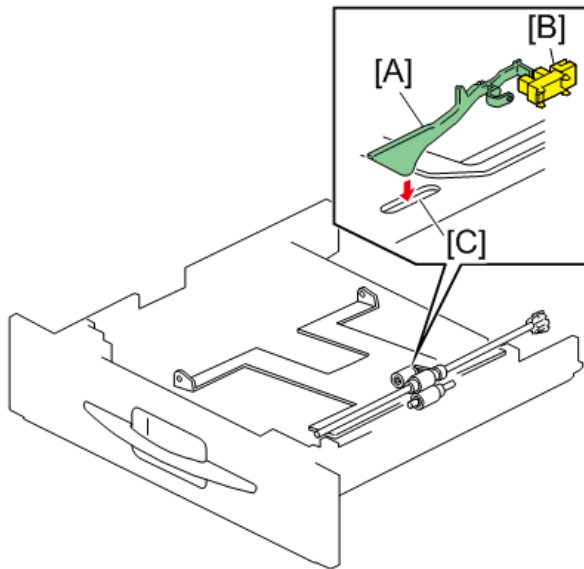

d245k9046

If there is some paper in the paper tray, the paper stack raises the paper end feeler [A] and the paper end sensor [B] is deactivated.

When the paper tray runs out of paper, the paper end feeler drops into the cutout [C] in the tray bottom plate and the paper end sensor is activated.

When the paper tray is drawn out with no paper in the tray, the paper end feeler is not caught in the paper tray due to its shape.

## 2.1.5 SIDE FENCES

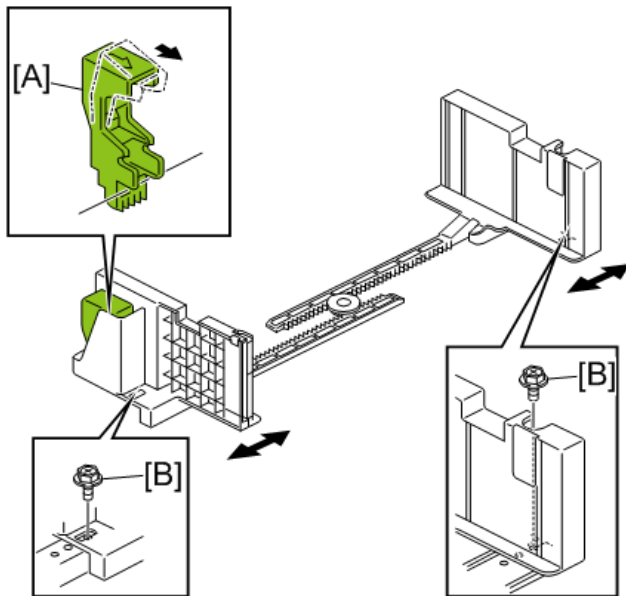

d245k9048

If the tray is full of paper and it is pushed in strongly, the fences may deform or bend. This may cause the paper to skew or the side-to-side registration to be incorrect. To correct this, each side fence has a stopper [A] attached to it. Each side fence can be secured with a screw [B], for customers who do not want to change the paper size.