

# **Xerox Phaser 3635 MFP Service Manual**

About This Manual ..... iii  
Warnings, Cautions And Notes ..... iii  
Safety Precautions ..... iv  
Health and Safety Incident reporting ..... v  
Translation of Warnings ..... vi

## About This Manual

This manual is part of a multinational service documentation system that is structured in the standard Xerox service manual format.

### Organization

The service manual is the document used as the primary information source for repairing and maintaining this family of products and is available as EDOC on a CDROM, or in printed format. The information within the manual is divided into an introduction and eight other sections.

#### Section 1 Service Call Procedures

This section is used to start and complete a service call. The procedures in this section will either direct you to a Repair Analysis Procedure (RAP), or identify a faulty component or sub-assembly.

#### Section 2 Status Indicator Repair Analysis Procedures

This section contains the Repair Analysis Procedures (RAPs) and checkouts necessary to diagnose, isolate and repair faults other than image quality faults.

#### Section 3 Image Quality

This section contains the Image Quality Repair Analysis Procedures (IQ RAPs), checkouts and setup procedures necessary to diagnose, isolate and repair image quality faults.

#### Section 4 Repairs/Adjustments

This section contains the instructions for removal, replacement, and adjustment of parts within the machine.

#### Section 5 Parts List

This section contains the detailed and illustrated spare parts list. Any part that is spared or that must be removed to access a spared part is illustrated.

#### Section 6 General Procedures / Information

This section contains all other procedures, product specifications and general information.

#### Section 7 Wiring Data

This section contains the wiring diagrams.

#### Section 8 Accessories

This section contains details of any accessories that the machine may have.

#### Publication Comments Sheet

A Publication Comment Sheet is provided at the rear of the hardcopy manual.

### Component Names

Some plastic components have the manufacturer's component name molded on them. These component names have not been used in this manual.

## Warnings, Cautions And Notes

A translated version of all warnings is in Translation of Warnings.

### WARNING

**A warning is used whenever an operating or maintenance procedure, practice, condition or statement, if not strictly observed, could result in personal injury.**

### CAUTION

*A caution is used whenever an operation or maintenance procedure, practice, condition or statement, if not strictly observed, could result in damage to the equipment.*

**NOTE:** *A note is used where it is essential to highlight a procedure, practice, condition or statement.*

The following are examples of the symbols that are used in this manual for an electrostatic damage caution and laser radiation warning.

#### ESD caution symbol



### CAUTION

*Certain components in this product are susceptible to damage from electrostatic discharge. Observe all ESD procedures to avoid component damage.*

#### Laser radiation warning symbol.



### WARNING

**Follow the service procedure exactly as written. Use of controls or adjustments other than those specified in this manual, may result in an exposure to invisible laser radiation. During servicing, the invisible laser radiation can cause eye damage if looked at directly.**

## Safety Precautions

Follow these safety, ESD, and servicing precautions to prevent personal injury and equipment damage.

1. Ensure that all built in protective devices are in place. Restore any missing protective shields.
2. Make sure there are no cabinet openings through which people, particularly children, might insert fingers or objects and contact dangerous voltages.
3. When re-installing chassis and assemblies, be sure to restore all protective devices, including control knobs and compartment covers.
4. Design alteration warning; never alter or add to the mechanical or electrical design of this equipment, such as auxiliary connectors, etc. Such alterations and modifications will void the manufacturers warranty.
5. Components, parts, and wiring that appear to have overheated or are otherwise damaged should be replaced with parts which meet the original specifications. Always determine the cause of damage or overheating, and correct any potential hazards.
6. Observe the original harness routing, especially near sharp edges, AC, and high voltage power supplies. Always inspect for pinched, out-of-place, or frayed wiring. Do not change the spacing between components and the printed circuit board.
7. Product safety notice; some electrical and mechanical parts have special safety related characteristics which might not be obvious from visual inspection. These safety features and the protection they provide could be lost if a replacement component differs from the original. This holds true, even though the replacement may be rated for higher voltage, wattage, etc.
8. Use only replacement components that have the same ratings, especially for flame resistance and dielectric specifications. A replacement part that does not have the same safety characteristics as the original may create shock, fire, or other safety hazards.

### ESD Precautions

1. Certain semiconductor devices can be easily damaged by static electricity. Such components are commonly called 'Electrostatically Sensitive (ES) Devices', or ESDs. Examples of typical ESDs are: integrated circuits, some field effect transistors, and semiconductor 'chip' components.

The techniques outlined below should be followed to help reduce the incidence of component damage caused by static electricity.

#### CAUTION

*Ensure no power is applied to the chassis or circuit, and observe all other safety precautions.*

2. Immediately before handling a semiconductor component or semiconductor-equipped assembly, discharge any electrostatic charge on your body by touching a known earth ground. Alternatively, employ a commercially available wrist strap device, which should be removed for your personal safety reasons prior to applying power to the unit under test.
3. After removing an electrical assembly equipped with ESDs, place the assembly on a conductive surface, such as aluminum or copper foil, or conductive foam, to prevent electrostatic charge buildup in the vicinity of the assembly.
4. Use only a grounded tip soldering iron to solder or desolder ESDs.  
Use only an 'anti-static' solder removal device. Some solder removal devices not classified as 'anti-static' can generate electrical charges sufficient to damage ESDs.

5. Do not use freon propelled chemicals. When sprayed, these can generate electrical charges sufficient to damage ESDs.
6. Do not remove a replacement ESD from its protective packaging until immediately before installing it. Most replacement ESDs are packaged with all leads shorted together by conductive foam, aluminum foil, or a comparable conductive material.
7. Immediately before removing the protective shorting material from the leads of a replacement ESD, touch the protective material to the chassis or circuit assembly into which the device will be installed.
8. Maintain continuous electrical contact between the ESD and the assembly into which it will be installed, until completely plugged or soldered into the circuit.
9. Minimize body motion when handling unpacked replacement ESDs. Normal motions, such as the brushing together of clothing fabric and lifting a foot from a carpeted floor, can generate static electricity sufficient to damage an ESD.

### Lithium Battery Precautions

1. Exercise caution when replacing a lithium battery. There could be a danger of explosion and subsequent operator injury and/or equipment damage if incorrectly installed.
2. Be sure to replace the battery with the same or equivalent type recommended by the manufacturer.
3. Lithium batteries contain toxic substances and should not be opened, crushed, or burned for disposal.
4. Dispose of used batteries according to the manufacture's instructions.

# Health and Safety Incident reporting

## I. Summary

This section defines requirements for notification of health and safety incidents involving Xerox products (equipment and materials) at customer locations.

## II. Scope

Xerox Corporation and subsidiaries worldwide.

## III. Objective

To enable prompt resolution of health and safety incidents involving Xerox products and to ensure Xerox regulatory compliance.

## IV. Definitions

Incident:

An event or condition occurring in a customer account that has resulted in injury, illness or property damage. Examples of incidents include machine fires, smoke generation, physical injury to an operator or service representative. Alleged events and product conditions are included in this definition.

## V. Requirements

Initial Report:

1. Xerox organisations shall establish a process for individuals to report product incidents to Xerox Environment Health & Safety within 24 hours of becoming aware of the event.
2. The information to be provided at the time of reporting is contained in Appendix A (Health and Safety Incident Report involving a Xerox product).
3. The initial notification may be made by any of the following methods:
  - For incidents in North America and Developing Markets West (Brazil, Mexico, Latin American North and Latin American South):
    - Phone\* Xerox EH&S at: 1-800-828-6571.
    - Electronic mail Xerox EH&S at: Doris.Bush@xerox.com.
    - Fax Xerox EH&S at: 1-585-422-6449 [intelnet 8\*222 6449].
  - For incidents in Europe and Developing Markets East (Middle East, Africa, India, China and Hong Kong):
    - Phone\* Xerox EH&S at: +44 (0) 1707 353434.
    - Electronic mail Xerox EH&S at: Elaine.Grange@xerox.com.
    - Fax Xerox EH&S at: +44 (0) 1707 353914 [intelnet 8\*668 3914].

\*Initial notification made by phone must be followed within 24 hours by a completed incident report and sent to the indicated electronic mail address or fax number.

**NOTE:** *If sending a fax, please also send the original via internal mail.*

Responsibilities for resolution:

1. Business Groups/Product Design Teams responsible for the product involved in the incident shall:
  - a. Manage field bulletins, customer correspondence, product recalls, safety retrofits.
  - b. Fund all field retrofits.

2. Field Service Operations shall:
  - a. Preserve the Xerox product involved and the scene of the incident inclusive of any associated equipment located in the vicinity of the incident.
  - b. Return any affected equipment/part(s) to the location designated by Xerox EH&S and/or the Business Division.
  - c. Implement all safety retrofits.
3. Xerox EH&S shall:
  - a. Manage and report all incident investigation activities.
  - b. Review and approve proposed product corrective actions and retrofits, if necessary.
  - c. Manage all communications and correspondence with government agencies.
  - d. Define actions to correct confirmed incidents.

## VI. Appendices

The Health and Safety Incident Report involving a Xerox Product (Form # EH&S-700) is available in the following locations:

- On electronic documentation (EDOC), located in the folder \safety.
- In the hardcopy, located at the end of the manual.

---

# 1 Service Call Procedures

SCP 1 Initial Actions.....	1-3
SCP 2 First Call Actions.....	1-3
SCP 3 Normal Call Actions.....	1-4
SCP 4 Fault Analysis.....	1-4
SCP 5 Subsystem Maintenance.....	1-5
SCP 6 Final Actions.....	1-6
SCP 7 Machine Configurations and Options.....	1-7

## SCP 1 Initial Actions

Initial Actions are used to gather information on the machine performance

Start a service call with SCP 1 and end with SCP 6 Final Actions.

Also refer to SCP 7 Machine Configurations and Options.

### Procedure

#### WARNING

Switch off the electricity to the machine. Disconnect the power cord from the customer supply while performing tasks that do not need electricity. Electricity can cause death or injury. Moving parts can cause injury.

#### WARNING

Do not work in a confined space. 1m (39 inches) space is needed for safe working.

**NOTE:** Ignore any references in this manual to options not installed on the machine.

1. Take note of symptoms or error messages.
2. Ask the operator to describe or demonstrate the problem.
3. Make sure that:
  - a. The power cord is connected to the wall outlet and to the machine.
  - b. Documents are not loaded in the DADF or on the document glass.
  - c. Paper is loaded correctly and all paper trays and covers are closed
  - d. If installed, the telephone line cable is connected correctly between the line socket and the wall jack.
  - e. If installed, the telephone line is good.
  - f. If installed, the USB cable or network connection is installed correctly.
4. If available, check the machine service log book for any previous actions that may be relevant to the call.
5. If this is the first service call to this machine perform SCP 2 First Call Actions, otherwise go to SCP 3 Normal Call Actions.

## SCP 2 First Call Actions

First Call Actions are used for the first service call.

### Procedure

1. Check the machine configuration with the customer, refer to SCP 7 Machine Configurations and Options. Check that all required hardware and software is installed and/or enabled.
2. Check that all the relevant machine settings are correctly entered, refer to GP 4 System Administration Tools.
3. Mark off any hardware/software options and modifications installed and/or enabled on the Tag plate. Refer to Change Tags.
4. If a fault is present, go to SCP 3 Normal Call Actions. If there is no fault present, go to SCP 6 Final Actions.
5. Enter the machine details and the customer details in the service log.

## SCP 3 Normal Call Actions

Normal Call Actions are used to determine the reason for the service call.

### Procedure

**NOTE:** If a fault message appears at any time. Refer directly to the RAP for the fault message and perform the procedure.

If possible, perform the following:

1. Review any defective print or copy samples.
2. Determine that the user accessible settings are correct. If necessary refer to the user documentation.
3. Check all job queues and verify with the customer any requirement to print the documents in memory, before switching off the power or clearing memory.
4. Print the Customer Assistance Report (Call for Assistance), then record the total print count.
5. Go to SCP 4 Fault Analysis.

## SCP 4 Fault Analysis

Fault Analysis is used to identify a fault.

### Procedure

When diagnosing or repairing a fault in a particular subsystem, exercise the machine in all modes until the fault is determined. In the instance of finding more than one fault or failure, correct one fault before going to the next fault. If no fault is found, go to SCP 5 Subsystem Maintenance.

### Fault Codes

If a fault code is displayed, go to the relevant RAP.

### Power Failure

If the machine fails to switch on, go to the 01A Power Failure RAP.

### Boot Failure

If the machine is in a continuous boot cycle and does not come to a Ready to Copy state, go to the OF6 Unable to Boot RAP.

### UI Faults

If the machine is on but the UI is blank, go to the OF2 UI Touch Screen Error RAP.

### Fax Faults

If the machine has a fax fault, go to the 20A Fax Faults Without a Code RAP.

### Stapler Faults

If the machine has a stapler fault, go to the OF5 Stapler Fault RAP.

### Copying Faults

If the machine does not copy correctly when the customer uses features such as auto size detect, edge erase, book copying and image shift, go to the OF4 Copying Error RAP.

### Audible Noise

If the machine is making an unusual noise, go to the OF1 Audible Noise RAP.

### Overheating or Smells

If the machine is creating excessive heat or odors, go to the OF3 Air Systems RAP.

### Image Quality Defects

If the image quality is defective, go to the IQ1 Image Quality Entry RAP.

For image quality specifications, refer to the following:

- IQS 1 Solid Area Density.
- IQS 2 Skew.
- IQS 3 Registration.

## Machine Settings

To make any adjustments to the machine, refer to ADJ 1.1 Machine Settings.

## Additional Information

If necessary, refer to the following general procedures and information:

- GP 1 Diagnostics Entry
- GP 2 Fault Codes and History Files
- GP 3 Machine Status
- GP 4 System Administration Tools
- GP 5 Reports
- GP 6 Firmware Upgrade
- GP 7 Machine Specifications
- GP 8 DADF Document Feeding Specifications
- GP 9 Paper and Media Specifications
- GP 10 General Disassembly Precautions
- GP 11 Service Information
- GP 12 User Interface Tests Description
- GP 13 Installation Space Requirements
- GP 14 Glossary of Terms, Acronyms and Abbreviations
- GP 15 Shading Test
- GP 16 High Frequency Service Items
- GP 17 Restriction of Hazardous Substances (RoHS)
- GP 18 Scan Edge Print

## SCP 5 Subsystem Maintenance

Subsystem Maintenance contains information regarding the component life of the machine.

## Procedure

### WARNING

**Switch off the electricity to the machine. Disconnect the power cord from the customer supply while performing tasks that do not need electricity. Electricity can cause death or injury. Moving parts can cause injury.**

Go to the relevant procedure:

- Component Life
- HFSI

## Component Life

The design life of the major components are shown in Table 1. Environmental conditions and actual use will vary these factors. The component life shown in Table 1 is for reference only.

**Table 1 Component life expectancies**

Part	Component life	Parts list reference
DADF retard pad assembly	50k feeds	PL 5.30 Item 2
DADF pickup assembly	80k feeds	PL 5.25 Item 2
Tray 1 pickup roll	150k feeds	PL 10.22 Item 14
Tray 2 pickup roll	150k feeds	PL 8.17 Item 31
Transfer roll	100k prints	PL 9.10 Item 2
Fuser assembly	100k prints	PL 10.10 Item 1
Starter print cartridge	5K prints	PL 9.10 Item 1
Print cartridge	10K prints	

## HFSI

The High Frequency Service Items are shown in Table 2. To change HFSI settings, refer to GP 16 High Frequency Service Items.

**Table 2 High frequency service items**

Item	Component	Description	The recommended life for new component installation	Parts list reference
Print Cartridge Life Page	Print cartridge	The total sides of copies and prints after the last HFSI reset.	10k impressions	PL 9.10 Item 1
Tray 1 Pickup Roll	Tray 1 pickup roll assembly	All sheets fed from tray 1 after last HFSI reset.	150k feeds	PL 10.22 Item 14
Tray 2 Pickup Roll	Tray 2 pickup roll assembly	All sheets fed from tray 2 after last HFSI reset.	150k feeds	PL 8.17 Item 31
Bypass Pickup Roll	Bypass tray retard pad	All sheets fed from the bypass tray after last HFSI reset.	150k feeds	PL 7.10 Item 27
Transfer Roll	Transfer roll	The total sides of copies and prints after the last HFSI reset.	100k impressions	PL 9.10 Item 2
Fuser Unit	Fuser assembly	The total sides of copies and prints after the last HFSI reset.	100k impressions	PL 10.10 Item 1

## SCP 6 Final Actions

Final Actions are used to evaluate the total operation of the system and to identify the actions required to complete the service call.

### Procedure

Complete the following, if a fault is identified, return to SCP 4 Fault Analysis:

- Perform the end of call subsystem maintenance actions, SCP 5 Subsystem Maintenance.
- Exercise the machine in all modes, making copies and/or prints from all trays, utilizing the DADF and the document glass. If a fault message is displayed or some other problem is evident, go to SCP 4 Fault Analysis.
- Make a proof copy or print of a customer document.
- If any of the customers selections were changed, return them to the customers preferred settings. Refer to GP 4 System Administration Tools.
- Mark off any hardware/software options and modifications installed and/or enabled on the Tag matrix card.
- At the first service and at any subsequent service where changes are made or options are added, print the configuration report and store it with machine log book. Discard any previous versions of the configuration report.
- Remove and destroy any copies of test patterns.
- Complete the machine service log book.
- Ensure the machine and service area are clean before leaving the customer premises.
- Provide customer training if required.

# SCP 7 Machine Configurations and Options

## Machine Configurations and Options

The Phaser 3635MFP is available in 2 configurations. Refer to Table 1 for the basic configurations and customer options.

This service manual covers all configurations. Within this manual ignore any references to options that are not installed.

**Table 1 Machine Configurations**

Features	Phaser 3635MFP/S	Phaser 3635MFP/X
Basic copier with paper tray 1	Yes	Yes
Paper tray 2	Optional	Yes
Bypass tray	Yes	Yes
Stand	Optional	Optional
Duplex assembly	Yes	Yes
DADF	Yes	Yes
20 Sheet stapler	Yes	Yes
Direct printing	Yes	Yes
Network printing	Yes	Yes
Fax	No	Yes
Scan to e-mail	No	Yes
Foreign device interface (service install option)	Optional	Optional
80Gb hard disk	Yes	Yes
System memory (256Mb)	Yes	Yes
Additional memory (256Mb)	Optional	Optional
Server Fax	Optional	Optional
Network Accounting	Optional	Optional

## 2 Status Indicator RAPs

### Chain 1 - Standby Power

01-100 Door Open RAP .....	2-3
01-110 Fuser Door Open RAP .....	2-3
01-700 Stapler Door Open RAP .....	2-4
01A Power Failure RAP .....	2-4

### Chain 2 - User Interface

02-100, 200 USB Faults RAP .....	2-7
----------------------------------	-----

### Chain 3 - Machine Run Control

03-200, 210, 220, 230, 240, 250 MSOK Faults RAP .....	2-9
03-300, 310, 320, 330, 340 OSOK Faults RAP .....	2-9
03-410, 411, 412 Tray 1 Paper Information Mismatch RAP .....	2-10
03-420, 421, 422 Tray 2 Paper Information Mismatch RAP .....	2-10
03-450 Bypass Tray Paper Information Mismatch RAP .....	2-11
03-510, 520, 558, 559 Foreign Device Interface Fault RAP .....	2-11
03-600 Memory Failure RAP .....	2-12
03-800 Check HDD RAP .....	2-12
03-900 Main PWB to GUI Communications Fault RAP .....	2-13
03-940 Main PWB to Tray 2 Communications Fault RAP .....	2-13
03-970 Main PWB Watchdog Detects Software Lockup RAP .....	2-14

### Chain 5 - DADF

05-100 DADF Jam 1 RAP .....	2-15
05-500 DADF Jam 5 RAP .....	2-15
05-600 DADF Jam 6 RAP .....	2-16
05-700 DADF Jam 7 RAP .....	2-16
05-900 DADF Jam 0 RAP .....	2-17
05-920 DADF Door Open RAP .....	2-17

### Chain 6 - LSU

06-100, 06-200 LSU Error RAP .....	2-19
------------------------------------	------

### Chain 7 - Paper Supply

07-110 Paper Empty at Tray 1 RAP .....	2-21
07-130 Jam 0 From Tray 1 RAP .....	2-21
07-210 Paper Empty at Tray 2 RAP .....	2-22
07-230 Jam 0 From Tray 2 RAP .....	2-22
07-231 Check the Tray Feed Area RAP .....	2-23
07-500 Paper Empty at Bypass Tray RAP .....	2-24
07-530 Jam 0 From the Bypass Tray RAP .....	2-24

### Chain 8 - Paper Transport

08-100 Jam 1 RAP .....	2-25
08-200 Jam in Tray RAP .....	2-25
08-500 Jam 2 RAP .....	2-26
08-600 Duplex Jam 0 RAP .....	2-26
08-610 Duplex Jam 1 RAP .....	2-27
08-700 Out Bin Full RAP .....	2-27

### Chain 9 - Xerographics

09-100 Toner Low RAP .....	2-29
09-350 Print Cartridge Warning RAP .....	2-29
09-450 Replace Drum RAP .....	2-30
09-550, 820, 830 Print Cartridge Communications Error RAP .....	2-30

### Chain 10 - Fusing and Copy/Print Transport

10-100, 200 Open Fuser Error/Low Heat Error RAP .....	2-31
10-300 Over Heat Error RAP .....	2-31
10-500 Fuser Warning RAP .....	2-32
10-510 Replace Fuser RAP .....	2-32

### Chain 14 - Scanner

14-100 CCD Lock RAP .....	2-33
---------------------------	------

### Chain 15 - Scan to Email

15-100 to 15-500 Scan to E-mail Faults RAP .....	2-35
--	------

### Chain 17 - Network Controller

17-100 to 610 Network Controller Faults RAP .....	2-37
17-700 to 810 Server Error RAP .....	2-38
17-900 802.1X Authentication Error RAP .....	2-38

### Chain 20 - Fax

20-100 to 20-900 Fax Faults RAP .....	2-39
20A Fax Faults Without a Code RAP .....	2-40

### OF - Other Faults

OF1 Audible Noise RAP .....	2-41
OF2 UI Touch Screen Error RAP .....	2-42
OF3 Air Systems RAP .....	2-43
OF4 Copying Error RAP .....	2-43
OF5 Stapler Fault RAP .....	2-44
OF6 Unable to Boot RAP .....	2-44
OF7 Main PWB Check RAP .....	2-45

## 01-100 Door Open RAP

**01-100** The machine has detected that the front door is open. When the front door is open there is no +24V supply to the motors or the HVPS.

### Procedure

#### WARNING

**Switch off the electricity to the machine. Disconnect the power cord from the customer supply while performing tasks that do not need electricity. Electricity can cause death or injury. Moving parts can cause injury.**

Refer to Wiring Diagram 2. Perform the following:

1. Switch off the machine, then switch on the machine.
2. Check that the interlock switch actuator on the front cover assembly, PL 28.10 Item 7 is not missing or damaged. If necessary, install a new front cover assembly.
3. Check that the front cover assembly closes correctly.
4. If necessary, install a new HVPS, PL 1.10 Item 3.

**NOTE:** *The front door interlock switch is mounted on the HVPS.*

## 01-110 Fuser Door Open RAP

**01-110** The machine has detected that the fuser door is open. When the front door is open there is no +24V supply to the motors or the HVPS.

### Procedure

#### WARNING

**Switch off the electricity to the machine. Disconnect the power cord from the customer supply while performing tasks that do not need electricity. Electricity can cause death or injury. Moving parts can cause injury.**

Refer to Wiring Diagram 2. Perform the following:

1. Switch off the machine, then switch on the machine.
2. Open the rear door, then the fuser door, PL 10.12 Item 19.
3. Check that the interlock switch actuator on the fuser door, PL 10.12 Item 19 is not missing or damaged. If necessary, install a new fuser door.
4. Check that the fuser door assembly closes correctly.
5. If necessary, install a new HVPS, PL 1.10 Item 3.

**NOTE:** *The fuser door interlock switch is mounted on the HVPS.*

## 01-700 Stapler Door Open RAP

**01-700** The machine has detected that the stapler door is open. When the stapler door is open there is no +24V to the stapler.

### Procedure

#### WARNING

**Switch off the electricity to the machine. Disconnect the power cord from the customer supply while performing tasks that do not need electricity. Electricity can cause death or injury. Moving parts can cause injury.**

Refer to Wiring Diagram 9. Perform the following:

1. Switch off the machine, then switch on the machine.
2. Open the stapler door, PL 28.10 Item 9.
3. Check that the interlock switch actuator on the stapler door is not missing or damaged. If necessary, install a new stapler door, PL 28.10 Item 9.
4. Check that the stapler door assembly closes correctly.
5. Check the stapler door interlock switch. If necessary, install a new stapler door interlock switch, PL 11.10 Item 2.

**NOTE:** *There is no component control code for the stapler door interlock switch.*

6. Check the wiring between the stapler door interlock switch and CN3 on the Connection PWB.
7. If necessary, install a new connection PWB, PL 3.10 Item 17.

## 01A Power Failure RAP

Use this RAP to identify the cause of a power supply failure.

### Procedure

#### WARNING

**Switch off the electricity to the machine. Disconnect the power cord from the customer supply while performing tasks that do not need electricity. Electricity can cause death or injury. Moving parts can cause injury.**

#### WARNING

**Take care when measuring AC mains (line) voltage. Electricity can cause death or injury.**

#### WARNING

**Do not repair or install a new fuse F01 on the SMPS. Repairing or installing a new fuse can cause overheating and a risk of fire.**

**NOTE:** *Throughout this procedure, where further steps require the reconnection of a component, ensure they are reconnected before performing the next step.*

Refer to Wiring Diagram 1, Wiring Diagram 2, Wiring Diagram 3, Wiring Diagram 4, Wiring Diagram 5, Wiring Diagram 6, Wiring Diagram 7, Wiring Diagram 8, Wiring Diagram 9, Wiring Diagram 10 and Wiring Diagram 11. Perform the following:

1. Ensure the supply voltage is correct. If possible, connect the machine to a known good power supply. If the original power supply is faulty, inform the customer.
2. Disconnect the power cord from the power outlet and the machine. Check the continuity of the power cord. If necessary, install a new power cord.
3. Disconnect CON1 on the SMPS. Check for AC supply voltage between pins 1 and 2 on the connector. If necessary, install a new SMPS assembly, PL 1.12 Item 8.
4. Check the fuse F01 on the SMPS. If necessary, install a new SMPS assembly, PL 1.12 Item 8.

**NOTE:** *Fuse F01 is not spared.*

5. Remove the fuser, PL 10.10 Item 1. Check for continuity across the fuser heat lamp. Install new components as necessary, PL 10.12 and PL 10.15.

**NOTE:** *A cold fuser heat roll has a resistance of approximately 9 ohms (220V/240V) or 1.6 ohms (110V).*

6. Switch off the power to the machine. Disconnect all connectors on the Connection PWB except CN5 and CN6.
7. Switch on the power to the machine. If the machine switches on, perform step 8. If the machine fails to switch on, go to step 9.
8. Sequentially reconnect each connector onto the Connection PWB. If the faulty circuit is identified, repair the wiring or install components as necessary. If the machine still fails to switch on, install a new connection PWB, PL 3.10 Item 17.
9. Reconnect all connectors onto the Connection PWB. Disconnect all connectors from the Main PWB except CN26 and CN31.
10. Switch on the power to the machine. If the machine switches on, perform step 11. If the machine fails to switch on, go to step 12.

11. Sequentially reconnect each connector onto the Main PWB. If the faulty circuit is identified, repair the wiring or install components as necessary. If the machine still fails to switch on perform OF7 Main PWB Check RAP.
12. Reconnect all connectors onto the Main PWB. Disconnect CN4 from the HVPS, refer to REP 1.2.
13. Re-install the HVPS. Switch on the machine. If the machine switches on, check the wiring between the HVPS and the tray 1 paper empty sensor. Install new components as necessary, PL 1.10 and PL 10.22. If the machine fails to switch on, install a new HVPS, PL 1.10 Item 3.
14. If the fault is still present:
  - a. Install new components as necessary:
    - SMPS assembly, PL 1.12 Item 8.
    - Connection PWB, PL 3.10 Item 17.
    - HVPS, PL 1.10 Item 3.
  - b. Perform OF7 Main PWB Check RAP.

## 02-100, 200 USB Faults RAP

**02-100** The USB device is invalid. Only SCSI type memory is supported.

**02-200** The USB memory is full or there is no response from the USB memory.

### Procedure

#### WARNING

**Switch off the electricity to the machine. Disconnect the power cord from the customer supply while performing tasks that do not need electricity. Electricity can cause death or injury. Moving parts can cause injury.**

Refer to Wiring Diagram 5. Perform the following:

1. Make sure that the customer is using a valid USB device with sufficient free space.
2. Check the wiring between the USB host PWB, PL 3.10 Item 11 and CN7 on the Main PWB.
3. Install new components as necessary:
  - USB harness, PL 3.10 Item 13
  - USB host PWB, PL 3.10 Item 11
4. Perform OF7 Main PWB Check RAP.

## 03-200, 210, 220, 230, 240, 250 MSOK Faults RAP

These are the faults displayed when the machine encounters MSOK problems. The faults are listed in code order, together with any recommended actions.

### Messages

#### WARNING

**Switch off the electricity to the machine. Disconnect the power cord from the customer supply while performing tasks that do not need electricity. Electricity can cause death or injury. Moving parts can cause injury.**

Refer to Wiring Diagram 6.

#### 03-200 System Fault - IOT Serial Number Invalid, Call for Assistance

The IOT serial number is invalid. Perform the following:

1. Contact Field Engineering for assistance.

#### 03-210 System Fault - MSOK Invalid - Call for Assistance (MMSOK)

The MSOK serial number is invalid. Perform the following:

1. Contact Field Engineering for assistance.

#### 03-220 System Fault - MSOK Invalid - Call for Assistance MMSOK Bit

The MSOK has the manufacturing SOK serial number but not the MMSOK part. Perform the following:

1. Contact Field Engineering for assistance.

#### 03-230 System Fault - MSOK Page Count Exceeded

The IOT has attempted to print more pages than the MMSOK can print. Perform the following:

1. Remove the MMSOK, then install the MSOK.
2. Contact Field Engineering for further assistance.

#### 03-240 System Fault - Invalid Machine or MSOK SN

The MSOK SN is empty. Perform the following:

1. Contact Field Engineering for assistance.

#### 03-250 MSOK Missing

The MSOK is not installed. Perform the following:

1. Check that the MSOK is connected to the main PWB.

## 03-300, 310, 320, 330, 340 OSOK Faults RAP

These are the faults displayed when the machine encounters OSOK problems. The faults are listed in code order, together with any recommended actions.

### Messages

#### WARNING

**Switch off the electricity to the machine. Disconnect the power cord from the customer supply while performing tasks that do not need electricity. Electricity can cause death or injury. Moving parts can cause injury.**

Refer to Wiring Diagram 5.

#### 03-300 System Fault - Message: Please Insert Option Key to Enable Machine Per BS

The machine has detected that the OSOK is not installed. Perform the following:

1. Install the PEK.
2. Contact Field Engineering for further assistance.

#### 03-310 System Fault - Message: OSOK Previously Used in Different Machine Per BS

The machine has detected that the OSOK has previously been used in a different machine. Perform the following:

1. Obtain, then install a valid FEK.
2. Contact Field Engineering for further assistance.

#### 03-320 System Fault - Option SIM Invalid

The machine has detected that the OSOK has previously been used in a different machine. Perform the following:

1. Obtain, then install a valid FEK.
2. Contact Field Engineering for further assistance.

#### 03-330 System Fault - Not Inserted Properly

The machine has detected that the OSOK is not installed correctly. Perform the following:

1. Remove, then reinstall the OSOK.
2. Contact Field Engineering for further assistance.

#### 03-340 Option Installed Remove SIM

The option has been successfully installed. Perform the following:

1. Remove the FEK.
2. Contact Field Engineering for further assistance.

### **03-410, 411, 412 Tray 1 Paper Information Mismatch RAP**

**03-410** The machine has detected a tray 1 paper colour, type or size mismatch during a print job.

**03-411** The machine has detected a tray 1 paper type mismatch during a print job.

**03-412** The machine has detected a tray 1 paper size mismatch during a print job.

#### **Procedure**

#### **WARNING**

**Switch off the electricity to the machine. Disconnect the power cord from the customer supply while performing tasks that do not need electricity. Electricity can cause death or injury. Moving parts can cause injury.**

Perform the following:

1. If the fault is present when printing, check that the print driver and machine tray information are correct.
2. Go to GP 4 System Administration Tools. Check that the relevant tray paper type, colour and size settings are correct.

### **03-420, 421, 422 Tray 2 Paper Information Mismatch RAP**

**03-420** The machine has detected a tray 2 paper colour, type or size mismatch during a print job.

**03-421** The machine has detected a tray 2 paper type mismatch during a print job.

**03-422** The machine has detected a tray 2 paper size mismatch during a print job.

#### **Procedure**

#### **WARNING**

**Switch off the electricity to the machine. Disconnect the power cord from the customer supply while performing tasks that do not need electricity. Electricity can cause death or injury. Moving parts can cause injury.**

Perform the following:

1. If the fault is present when printing, check that the print driver and machine tray information are correct.
2. Go to GP 4 System Administration Tools. Check that the relevant tray paper type, colour and size settings are correct.

## 03-450 Bypass Tray Paper Information Mismatch RAP

**03-450** The machine has detected a bypass tray paper colour, type or size mismatch during a print job.

### Procedure

#### WARNING

**Switch off the electricity to the machine. Disconnect the power cord from the customer supply while performing tasks that do not need electricity. Electricity can cause death or injury. Moving parts can cause injury.**

Perform the following:

1. If the fault is present when printing, check that the print driver and machine tray information are correct.
2. Go to GP 4 System Administration Tools. Check that the relevant tray paper type, colour and size settings are correct.

## 03-510, 520, 558, 559 Foreign Device Interface Fault RAP

**03-510** The foreign device interface is not detected.

**03-520** The foreign device interface is not active.

**03-558** The foreign device interface is not active.

**03-559** The foreign device interface is no longer active.

### Procedure

#### WARNING

**Switch off the electricity to the machine. Disconnect the power cord from the customer supply while performing tasks that do not need electricity. Electricity can cause death or injury. Moving parts can cause injury.**

Refer to Wiring Diagram 5. Perform the following:

1. If there is credit in the foreign device, check the wiring between the foreign device and the foreign device interface PWB, PL 3.10 Item 7.
2. Check that the foreign device interface PWB is securely connected to CN13 the Main PWB.
3. If necessary:
  - a. Install a new foreign device interface PWB, PL 3.10 Item 7.
  - b. Perform OF7 Main PWB Check RAP.

## 03-600 Memory Failure RAP

**03-600** The machine has detected a memory access failure.

### Procedure

#### **WARNING**

**Switch off the electricity to the machine. Disconnect the power cord from the customer supply while performing tasks that do not need electricity. Electricity can cause death or injury. Moving parts can cause injury.**

Refer to Wiring Diagram 6. Perform the following:

1. Switch off the machine, then switch on the machine.
2. Remove, then reinstall the memory DIMM, PL 3.10 Item 10.
3. If necessary:
  - a. Install a new memory DIMM, PL 3.10 Item 10.
  - b. Perform OF7 Main PWB Check RAP.

## 03-800 Check HDD RAP

**03-800** The machine has detected a fault with the hard disk drive (HDD).

### Procedure

#### **WARNING**

**Switch off the electricity to the machine. Disconnect the power cord from the customer supply while performing tasks that do not need electricity. Electricity can cause death or injury. Moving parts can cause injury.**

Refer to Wiring Diagram 5. Perform the following:

1. Switch off the machine, then switch on the machine.
2. Check the wiring between the hard disk drive and the Main PWB.
3. If necessary:
  - a. Install a new hard disk drive, PL 3.10 Item 16.
  - b. Perform OF7 Main PWB Check RAP.

## 03-900 Main PWB to GUI Communications Fault RAP

03-900 A user interface to main PWB communications error has been detected.

### Procedure

#### WARNING

Switch off the electricity to the machine. Disconnect the power cord from the customer supply while performing tasks that do not need electricity. Electricity can cause death or injury. Moving parts can cause injury.

Refer to Wiring Diagram 4. Perform the following:

1. Switch off the machine, then switch on the machine.
2. Check the wiring between CN6 on the Main PWB and CN2 on the UI PWB.
3. Check the wiring between CN10 on the Main PWB and CN11 on the UI PWB.
4. Check the wiring between CN11 on the Main PWB and CN1 on the UI PWB.
5. If necessary:
  - a. Install a new UI PWB, PL 2.10 Item 4.
  - b. Perform OF7 Main PWB Check RAP.

## 03-940 Main PWB to Tray 2 Communications Fault RAP

03-940 A main PWB to tray 2 PWB communications error has been detected.

### Procedure

#### WARNING

Switch off the electricity to the machine. Disconnect the power cord from the customer supply while performing tasks that do not need electricity. Electricity can cause death or injury. Moving parts can cause injury.

Refer to Wiring Diagram 7 and Wiring Diagram 11. Perform the following:

1. Switch off the machine, then switch on the machine.
2. Check the wiring between CN33 and CN34 on the Main PWB and CN7 on the Tray 2 PWB.
3. If necessary:
  - a. Install new components:
    - Tray 2 connector, PL 8.15 Item 9.
    - Tray 2 PWB, PL 8.17 Item 25.
  - b. Perform OF7 Main PWB Check RAP.

## **03-970 Main PWB Watchdog Detects Software Lockup RAP**

03-970 The main PWB software has stopped responding.

### **Procedure**

#### **WARNING**

**Switch off the electricity to the machine. Disconnect the power cord from the customer supply while performing tasks that do not need electricity. Electricity can cause death or injury. Moving parts can cause injury.**

Perform the following:

1. Switch off the machine, then switch on the machine.
2. Reload the software, GP 6.
3. Perform OF7 Main PWB Check RAP.

## 05-100 DADF Jam 1 RAP

**05-100** The lead edge of the document failed to actuate the scan sensor within the correct time after registration solenoid actuation.

### Procedure

#### WARNING

**Switch off the electricity to the machine. Disconnect the power cord from the customer supply while performing tasks that do not need electricity. Electricity can cause death or injury. Moving parts can cause injury.**

**NOTE:** The door open switch must be actuated to supply +24V to the motors and solenoids.

Refer to Wiring Diagram 10. Perform the following:

1. Open the DADF door assembly, PL 5.10 Item 3. Remove all jammed paper.
2. Check the document path for damage or obstructions.
3. Check that the following components are clean and rotate freely:
  - Registration roll, PL 5.35 Item 9.
  - Registration roll idlers, PL 5.15 Item 8.
4. Remove the transport assembly upper cover, PL 5.35 Item 13.
5. Check that the DADF scan sensor actuator, PL 5.35 Item 6 moves freely and is not damaged.
6. Enter dC330 code 05-140. Check the scan sensor (Q05-140), PL 5.35 Item 7. If necessary, install a scan sensor.
7. Check the wiring between the DADF scan sensor and CN1 on the DADF PWB.
8. Remove the DADF rear cover, PL 5.10 Item 9. Enter dC330 code 05-200. Check that the DADF scan motor, PL 5.40 Item 2 runs.
9. Check the wiring between the DADF scan motor and CN9 on the DADF PWB.
10. Open the DADF door assembly, PL 5.10 Item 3. Manually actuate the DADF door open sensor, PL 5.40 Item 13. While the DADF scan motor runs, stack the code 05-310 to energize the DADF registration solenoid (SOL05-310). Check that the registration roll, PL 5.35 Item 9 rotates.
11. Check the wiring between the DADF registration solenoid and CN8 on the DADF PWB.
12. If necessary, install new components:
  - DADF PWB, PL 5.15 Item 16.
  - DADF scan motor, PL 5.40 Item 2.
  - DADF registration solenoid, PL 5.40 Item 3.
  - DADF drive assembly, PL 5.40 Item 1.
  - Document transport assembly, PL 5.35 Item 14.

## 05-500 DADF Jam 5 RAP

**05-500** The machine has detected that the DADF door assembly is open during run.

### Procedure

#### WARNING

**Switch off the electricity to the machine. Disconnect the power cord from the customer supply while performing tasks that do not need electricity. Electricity can cause death or injury. Moving parts can cause injury.**

Refer to Wiring Diagram 10. Perform the following:

1. Open the DADF door assembly, PL 5.10 Item 3. Remove all jammed paper.
2. Remove all jammed paper from the DADF exit tray.
3. Open the DADF door assembly, PL 5.10 Item 3. Check that the door open sensor actuator is not damaged.
4. Enter dC330 code 05-160. Check the DADF door open sensor (Q05-160), PL 5.40 Item 13.
5. Check the wiring between the DADF door open sensor and CN5 on the DADF PWB. If necessary, install a new DADF door open sensor, PL 5.40 Item 13.
6. If necessary, install new components:
  - DADF PWB, PL 5.15 Item 16.
  - Document transport assembly, PL 5.35 Item 14.

## 05-600 DADF Jam 6 RAP

**05-600** The machine has detected that a DADF sensor is actuated when the machine is switched on.

### Procedure

#### WARNING

**Switch off the electricity to the machine. Disconnect the power cord from the customer supply while performing tasks that do not need electricity. Electricity can cause death or injury. Moving parts can cause injury.**

Refer to Wiring Diagram 10. Perform the following:

1. Open the DADF door assembly, PL 5.10 Item 3. Remove all jammed paper.
2. Remove all jammed paper from the DADF exit tray.
3. Check the document path for damage or obstructions.
4. Check that the following actuators move freely and are not damaged:
  - Document detect sensor actuator, PL 5.30 Item 18.
  - Paper length sensor actuator, PL 5.20 Item 9.
  - Registration sensor actuator, PL 5.35 Item 10.
  - Scan sensor actuator, PL 5.35 Item 6.
5. Enter dC330. Check the following sensors. Install new components as necessary:
  - Code 05-100, document detect sensor (Q05-100), PL 5.30 Item 17.
  - Code 05-120, paper length sensor (Q05-120), PL 5.20 Item 11.
  - Code 05-130, registration sensor (Q05-130), PL 5.35 Item 7.
  - Code 05-140, scan sensor (Q05-140), PL 5.35 Item 7.
6. Check the following wiring:
  - Between the document detect sensor, and CN5 on the DADF PWB.
  - Between the paper length sensor and CN10 on the DADF PWB.
  - Between the registration sensor and CN1 on the DADF PWB.
  - Between the scan sensor and CN1 on the DADF PWB.
7. If necessary, install new components:
  - DADF PWB, PL 5.15 Item 16.
  - Document transport assembly, PL 5.35 Item 14.

## 05-700 DADF Jam 7 RAP

**05-700** The machine has detected that an oversize document has been fed.

### Procedure

#### WARNING

**Switch off the electricity to the machine. Disconnect the power cord from the customer supply while performing tasks that do not need electricity. Electricity can cause death or injury. Moving parts can cause injury.**

Refer to Wiring Diagram 10. Perform the following:

1. Open the DADF door assembly, PL 5.10 Item 3. Remove all jammed paper.
2. Remove all jammed paper from the DADF exit tray.
3. Check that the customer is not attempting to feed documents outside of specification, refer to GP 8 DADF Document Feeding Specifications.
4. Check the pickup roll assembly, PL 5.25 Item 2. If necessary, install a new pickup roll assembly, PL 5.25 Item 2.
5. Check the retard pad assembly, PL 5.30 Item 2. If necessary, install a new retard pad, PL 5.30 Item 2.
6. Check that the registration sensor actuator, PL 5.35 Item 10 moves freely and is not damaged.
7. Enter dC330 code 05-130. Check the registration sensor (Q05-130), PL 5.35 Item 7.
8. Check the wiring between the registration sensor and CN1 on the DADF PWB. If necessary, install a new registration sensor, PL 5.35 Item 7.
9. If necessary, install new components:
  - DADF PWB, PL 5.15 Item 16.
  - Document transport assembly, PL 5.35 Item 14.

## 05-900 DADF Jam 0 RAP

**05-900** The lead edge of the document failed to actuate the registration sensor within the correct time.

### Procedure

#### WARNING

**Switch off the electricity to the machine. Disconnect the power cord from the customer supply while performing tasks that do not need electricity. Electricity can cause death or injury. Moving parts can cause injury.**

**NOTE:** The door open switch must be actuated to supply +24V to the motors and clutches.

Refer to Wiring Diagram 10. Perform the following:

1. Open the DADF door assembly, PL 5.10 Item 3. Remove all jammed paper.
2. Check the document path for damage or obstructions.
3. Check the pickup roll assembly, PL 5.25 Item 2. If necessary, install a new pickup roll assembly, PL 5.25 Item 2.
4. Check the retard pad assembly, PL 5.30 Item 2. If necessary, install a new retard pad assembly, PL 5.30 Item 2.
5. Check that the registration sensor actuator, PL 5.35 Item 10 moves freely and is not damaged.
6. Enter dC330 code 05-130. Check the registration sensor (Q05-130), PL 5.35 Item 7.
7. Check the wiring between the registration sensor and CN1 on the DADF PWB. If necessary, install a new registration sensor, PL 5.35 Item 7.
8. Enter dC330 code 05-201. Check that the DADF scan motor (MOT05-200), PL 5.40 Item 2 runs.
9. Check the wiring between the DADF scan motor and CN9 on the DADF PWB. If necessary, install a new DADF scan motor, PL 5.40 Item 2.
10. While the DADF scan motor runs, stack the code 05-300 to energize the pick up solenoid (SOL05-300). Check that the pickup roll, PL 5.25 Item 2 rotates.
11. Check the wiring between the pick up solenoid and CN7 on the DADF PWB. If necessary, install a new pick up solenoid, PL 5.40 Item 3.
12. If necessary, install new components:
  - DADF PWB, PL 5.15 Item 16.
  - DADF drive assembly, PL 5.40 Item 1.
  - Document transport assembly, PL 5.35 Item 14.

## 05-920 DADF Door Open RAP

**05-920** The machine has detected that the DADF door is open.

### Procedure

#### WARNING

**Switch off the electricity to the machine. Disconnect the power cord from the customer supply while performing tasks that do not need electricity. Electricity can cause death or injury. Moving parts can cause injury.**

Refer to Wiring Diagram 10. Perform the following:

1. Open the DADF door assembly, PL 5.10 Item 3. Check that the DADF door open sensor actuator is not missing or damaged. If necessary, install a new DADF door assembly, PL 5.10 Item 3.
2. Enter dC330 code 05-160. Check the DADF door open sensor (Q05-160), PL 5.40 Item 13.
3. Check the wiring between the DADF door open sensor and CN5 on the DADF PWB. If necessary, install a new DADF door open sensor, PL 5.40 Item 13.
4. If necessary, install a new DADF PWB, PL 5.15 Item 16.

## 06-100, 06-200 LSU Error RAP

**06-100** The machine has detected that the LSU did not reach a ready state within the correct time.

**06-200** The machine did not detect the laser beam within the correct time.

### Procedure

#### WARNING

**Switch off the electricity to the machine. Disconnect the power cord from the customer supply while performing tasks that do not need electricity. Electricity can cause death or injury. Moving parts can cause injury.**

#### WARNING

**Avoid exposure to laser beam. Invisible laser radiation.**

Refer to Wiring Diagram 5. Perform the following:

1. Switch off the machine, then switch on the machine.
2. Enter dC330 codes 06-100 and 06-110. Check that the LSU motor is up to normal speed.

**NOTE:** Code 06-110 will display low when the LSU motor runs at normal speed.

3. Check the wiring between the LSU and CN24 on the Main PWB.
4. Remove the print cartridge, PL 9.10 Item 1. Check that the LSU interlock switch actuator on the print cartridge is not damaged.
5. Check the LSU interlock switch, PL 6.10 Item 2.
6. Check the wiring between the LSU interlock switch and CN21 on the Main PWB. If necessary, install a new LSU interlock switch, PL 6.10 Item 2.
7. If necessary:
  - Install a new LSU, PL 6.10 Item 1.
  - Perform OF7 Main PWB Check RAP.

## 07-110 Paper Empty at Tray 1 RAP

07-110 The machine has detected that tray 1 is empty.

### Procedure

#### WARNING

Switch off the electricity to the machine. Disconnect the power cord from the customer supply while performing tasks that do not need electricity. Electricity can cause death or injury. Moving parts can cause injury.

Refer to Wiring Diagram 2. Perform the following:

1. Remove tray 1. Check that the tray 1 paper empty sensor actuator, moves freely and is not damaged.
2. Enter dC330 code 07-110. Check the tray 1 paper empty sensor (Q07-110), PL 10.22 Item 1. If necessary, install a new tray 1 paper empty sensor, PL 10.22 Item 1.
3. Check the wiring between the tray 1 paper empty sensor and CN4 on the Main PWB.
4. If necessary:
  - a. Install a new front duplex guide assembly, PL 10.22 Item 15.
  - b. Perform OF7 Main PWB Check RAP.

## 07-130 Jam 0 From Tray 1 RAP

07-130 The lead edge of the paper failed to actuate the registration sensor within the correct time after paper was fed from tray 1.

### Procedure

#### WARNING

Switch off the electricity to the machine. Disconnect the power cord from the customer supply while performing tasks that do not need electricity. Electricity can cause death or injury. Moving parts can cause injury.

**NOTE:** The front cover assembly interlock switch must be closed to supply +24V to the motors and clutches.

Refer to Wiring Diagram 7 and Wiring Diagram 8. Perform the following:

1. Pull out tray 1. Remove all jammed paper.
2. Check the paper path for damage or obstructions.
3. Remove the tray 1 pickup roll, PL 10.22 Item 14. Check that the pickup roll is clean. If necessary, install a new pickup roll, PL 10.22 Item 14.
4. Check the retard pad on tray 1. If necessary, install a new retard pad assembly, PL 8.10 Item 20.
5. Check that the following components are clean and rotate freely, install new components as necessary:
  - Registration roll, PL 8.25 Item 3.
  - Registration roll idler, PL 8.25 Item 17.
6. Check that the registration sensor actuator, PL 8.25 Item 14 moves freely and is not damaged. If necessary, install a new registration sensor actuator, PL 8.25 Item 14.
7. Enter dC330 code 08-500. Check the registration sensor (Q08-500). If necessary, install a new HVPS, PL 1.10 Item 3.

**NOTE:** The registration sensor is mounted on the HVPS.

8. Enter dC330 code 04-100 to run the main BLDC motor.
9. Check the wiring between the main BLDC motor and CN38 on the Main PWB.
10. While the main BLDC motor runs, stack the code 08-810 to energize the tray 1 pickup clutch (CL08-810). Check that the tray 1 pickup roll, PL 10.22 Item 14 rotates. Install new components as necessary, PL 8.25 and PL 10.22.
11. Check the wiring between the tray 1 pickup clutch and CN35 on the Main PWB.
12. While the main BLDC motor runs, stack the code 08-850 to energize the registration clutch (CL08-850). Check that the registration roll, PL 8.25 Item 3 does not rotate. Install new components as necessary, PL 8.25.
13. Check the wiring between the registration clutch and CN35 on the Main PWB.
14. If necessary:
  - Install a new front duplex guide assembly, PL 10.22 Item 15.
  - Perform OF7 Main PWB Check RAP.

## 07-210 Paper Empty at Tray 2 RAP

07-210 The machine has detected that tray 2 is empty.

### Procedure

#### WARNING

Switch off the electricity to the machine. Disconnect the power cord from the customer supply while performing tasks that do not need electricity. Electricity can cause death or injury. Moving parts can cause injury.

Refer to Wiring Diagram 7, Wiring Diagram 11. Perform the following:

1. Pull out tray 2. Check that the paper empty actuator, PL 8.17 Item 2 moves freely and is not damaged.
2. Enter dC330 code 07-230. Check the tray 2 paper empty sensor (S07-230), PL 8.17 Item 1.
3. Check the wiring between the paper empty sensor and CN1 on the Tray 2 PWB. If necessary, install a new paper empty sensor, PL 8.17 Item 1.
4. Check the wiring between CN7 on the Tray PWB and CN33 and CN34 on the Main PWB.
5. If necessary:
  - a. Install a new tray 2 PWB, PL 8.17 Item 25.
  - b. Perform OF7 Main PWB Check RAP.

## 07-230 Jam 0 From Tray 2 RAP

07-230 The lead edge of the paper failed to actuate the registration sensor within the correct time after paper was fed from tray 2.

### Procedure

#### WARNING

Switch off the electricity to the machine. Disconnect the power cord from the customer supply while performing tasks that do not need electricity. Electricity can cause death or injury. Moving parts can cause injury.

**NOTE:** The front cover assembly interlock switch must be closed to supply +24V to the motors and clutches.

Refer to Wiring Diagram 7, Wiring Diagram 8 and Wiring Diagram 11. Perform the following:

1. Pull out tray 1 and tray 2. Remove all jammed paper.
2. Check the paper path for damage or obstructions.
3. Remove the pickup roll assembly, PL 8.17 Item 31. Check that the pickup roll is clean. If necessary, install a new pickup roll assembly, PL 8.17 Item 31.
4. Check the retard pad on tray 2. If necessary, install a new retard pad assembly, PL 8.10 Item 20.
5. Check that the following components are clean and rotate freely, install new components as necessary:
  - Registration roll, PL 8.25 Item 3.
  - Registration roll idler, PL 8.25 Item 17.
6. Check that the registration sensor actuator, PL 8.25 Item 14 moves freely and is not damaged. If necessary, install a new registration sensor actuator, PL 8.25 Item 14.
7. Enter dC330 code 08-500. Check the registration sensor (Q08-500). If necessary, install a new HVPS, PL 1.10 Item 3.

**NOTE:** The registration sensor is mounted on the HVPS.

8. Enter dC330 code 08-920 to run the tray 2 feed motor.
9. Check the wiring between the tray 2 feed motor and CN8 on the Tray 2 PWB.
10. While the tray 2 feed motor runs, stack the code 08-820 to energize the tray 2 pickup clutch (CL08-820). Check that the tray 2 pickup roll assembly, PL 8.17 Item 31 and feed roll, PL 8.17 Item 12 rotate. Install new components as necessary, PL 8.17.
11. Check the wiring between the tray 2 pickup clutch and CN11 on the Tray 2 PWB.
12. Enter dC330 code 04-100 to run the main BLDC motor.
13. Check the wiring between the main BLDC motor and CN38 on the Main PWB.
14. While the main BLDC motor runs, stack the code 08-850 to energize the registration clutch (CL08-850). Check that the registration roll, PL 8.25 Item 3 does not rotate. Install new components as necessary, PL 8.25.
15. Check the wiring between the registration clutch and CN35 on the Main PWB.
16. If necessary:
  - a. Install new components:
    - Front duplex guide assembly, PL 10.22 Item 15.
    - Tray 2 feed motor, PL 8.15 Item 23.
    - Tray 2 PWB, PL 8.17 Item 25.

- Tray 2 assembly, PL 8.15 Item 28.
- b. Perform OF7 Main PWB Check RAP.

## 07-231 Check the Tray Feed Area RAP

**07-231** The machine has detected that paper is jammed in the tray 2 paper feeding area at power on.

### Procedure

#### WARNING

**Switch off the electricity to the machine. Disconnect the power cord from the customer supply while performing tasks that do not need electricity. Electricity can cause death or injury. Moving parts can cause injury.**

**NOTE:** *The front cover assembly interlock switch must be closed to supply +24V to the motors and clutches.*

Refer to Wiring Diagram 11. Perform the following:

1. Pull out tray 2. Remove all jammed paper.
2. Remove the pickup roll assembly, PL 8.17 Item 31. Check that the pickup roll is clean. If necessary, install a new pickup roll assembly, PL 8.17 Item 31.
3. Enter dC330 code 08-920 to run the tray 2 feed motor.
4. Check the wiring between the tray 2 feed motor and CN8 on the Tray 2 PWB.
5. While the tray 2 feed motor runs, stack the code 08-820 to energize the tray 2 pickup clutch (CL08-820). Check that the tray 2 pickup roll assembly, PL 8.17 Item 31 and feed roll, PL 8.17 Item 12 rotate. Install new components as necessary, PL 8.17.
6. Check the wiring between the tray 2 pickup clutch and CN11 on the Tray 2 PWB.
7. If necessary, install new components:
  - Tray 2 feed motor, PL 8.15 Item 23.
  - Tray 2 PWB, PL 8.17 Item 25.
  - Tray 2 assembly, PL 8.15 Item 28.

## 07-500 Paper Empty at Bypass Tray RAP

07-500 The machine has detected a failure to feed from the bypass tray.

### Procedure

#### WARNING

Switch off the electricity to the machine. Disconnect the power cord from the customer supply while performing tasks that do not need electricity. Electricity can cause death or injury. Moving parts can cause injury.

Refer to Wiring Diagram 7. Perform the following:

1. Open the front cover assembly, PL 28.10 Item 7. Check that the paper feed area at the bypass tray is clean.
2. Check the operation of the bypass paper empty sensor actuator, PL 7.10 Item 22.
3. Enter dC330 code 07-510. Check the bypass paper empty sensor (S07-510), PL 7.10 Item 1.
4. Check the wiring between the bypass paper empty sensor and CN37 on the Main PWB. If necessary, install a new bypass paper empty sensor, PL 7.10 Item 1.
5. If necessary:
  - a. Install a new bypass feed assembly, PL 7.10 Item 29.
  - b. Perform OF7 Main PWB Check RAP.

## 07-530 Jam 0 From the Bypass Tray RAP

07-530 The registration sensor failed to actuate within the correct time after paper was fed from the bypass tray.

### Procedure

#### WARNING

Switch off the electricity to the machine. Disconnect the power cord from the customer supply while performing tasks that do not need electricity. Electricity can cause death or injury. Moving parts can cause injury.

**NOTE:** The front cover assembly interlock switch must be closed to supply +24V to the motors and clutches.

Refer to Wiring Diagram 7 and Wiring Diagram 8. Perform the following:

1. Switch off the machine, then switch on the machine.
2. Open the front cover assembly, PL 28.10 Item 7. Remove all jammed paper.
3. Check the paper path for damage or obstructions.
4. Check that the bypass pickup roll assembly, PL 7.10 Item 28 is clean. If necessary, install a new bypass pickup roll assembly, PL 7.10 Item 28.
5. Check the bypass tray retard pad. If necessary, install a new retard pad, PL 7.10 Item 27.
6. Check that the registration sensor actuator, PL 8.25 Item 14 moves freely and is not damaged. If necessary, install a new registration sensor actuator, PL 8.25 Item 14.
7. Enter dC330 code 08-500. Check the registration sensor (Q08-500). If necessary, install a new HVPS, PL 1.10 Item 3.  
  
**NOTE:** The registration sensor is mounted on the HVPS.
8. Enter dC330 code 04-100 to run the main BLDC motor.
9. Check the wiring between the main BLDC motor and CN38 on the Main PWB.
10. While the main BLDC motor runs, stack the code 08-800 to energize the bypass feed clutch (CL08-800). Check that the bypass pickup roll assembly, PL 7.10 Item 28 rotates.
11. Check the wiring between the bypass feed solenoid, PL 7.10 Item 4 and CN37 on the Main PWB.
12. If necessary:
  - a. Install a new bypass feed assembly, PL 7.10 Item 29.
  - b. Perform OF7 Main PWB Check RAP.

## 08-100 Jam 1 RAP

**08-100** The lead edge of the document failed to actuate the fuser exit sensor within the correct time after registration.

### Procedure

#### WARNING

**Switch off the electricity to the machine. Disconnect the power cord from the customer supply while performing tasks that do not need electricity. Electricity can cause death or injury. Moving parts can cause injury.**

#### WARNING

**Do not touch the fuser while it is hot.**

**NOTE:** *The front cover assembly interlock switch must be closed to supply +24V to the motors and clutches.*

Refer to Wiring Diagram 2, Wiring Diagram 8 and Wiring Diagram 9. Perform the following:

1. Switch off the machine, then switch on the machine.
2. Open the front cover assembly, PL 28.10 Item 7. Remove all jammed paper.
3. Remove the print cartridge, PL 9.10 Item 1 and the fuser module, PL 10.10 Item 1. Check the paper path for damage or obstructions.
4. Open the fuser door, PL 10.12 Item 19. Check the following, install new components as necessary:
  - a. The fuser exit sensor actuator, PL 10.12 Item 9 moves freely and is not damaged.
  - b. The fuser heat roll, PL 10.15 Item 1, pressure roll 1, PL 10.15 Item 2 and pressure roll 2, PL 10.15 Item 3 are clean and rotate freely.
  - c. The fuser exit roll, PL 10.12 Item 6 and idlers, PL 10.12 Item 17 are clean and rotate freely.
  - d. The fuser stripper fingers, PL 10.12 Item 13.
5. Enter dC330 code 08-600. Check the fuser exit sensor (Q08-600). If necessary, install a new HVPS, PL 1.10 Item 3.

**NOTE:** *The fuser exit sensor is mounted on the HVPS.*

6. Reinstall the fuser. Enter dC330 code 04-200. Check that the exit motor (MOT04-200), PL 10.20 Item 4, runs and drives the fuser rolls.
7. Check the wiring between the exit motor and CN2 on the Connection PWB. Install new components as necessary, PL 10.20.
8. Enter dC330 code 04-100 to run the main BLDC motor.
9. Check the wiring between the main BLDC motor and CN38 on the Main PWB.
10. If necessary:
  - a. Install a new print cartridge, PL 9.10 Item 1.
  - b. Perform OF7 Main PWB Check RAP.

## 08-200 Jam in Tray RAP

**08-200** The machine has detected a paper jam in the tray 2 feed area.

### Procedure

Go to the 07-230 Jam 0 from Tray 2 RAP.

## 08-500 Jam 2 RAP

**08-500** The trail edge of the document failed to deactuate the exit sensor within the correct time after registration.

### Procedure

#### WARNING

**Switch off the electricity to the machine. Disconnect the power cord from the customer supply while performing tasks that do not need electricity. Electricity can cause death or injury. Moving parts can cause injury.**

#### WARNING

**Do not touch the fuser while it is hot.**

**NOTE:** The front cover assembly interlock switch must be closed to supply +24V to the motors and clutches.

Refer to Wiring Diagram 2, Wiring Diagram 8 and Wiring Diagram 9. Perform the following:

1. Switch off the machine, then switch on the machine.
2. Open the rear door. Release the fuser pressure rolls, then remove all jammed paper.
3. Remove the fuser module, PL 10.10 Item 1. Check the paper path for damage or obstructions.
4. Open the fuser door, PL 10.12 Item 19. Check the following, install new components as necessary:
  - a. The fuser exit sensor actuator, PL 10.12 Item 9 moves freely and is not damaged.
  - b. The fuser heat roll, PL 10.15 Item 1, pressure roll 1, PL 10.15 Item 2 and pressure roll 2, PL 10.15 Item 3 are clean and rotate freely.
  - c. The fuser exit roll, PL 10.12 Item 6 and idlers, PL 10.12 Item 17 are clean and rotate freely.
  - d. The fuser stripper fingers, PL 10.12 Item 13.
5. Remove the exit drive assembly, PL 10.20 Item 11. Check the following components are clean and rotate freely:
  - a. Exit roll, PL 10.25 Item 22.
  - b. Exit roll idlers, PL 10.25 Item 3 and PL 10.25 Item 4.
  - c. Transport roll, PL 10.30 Item 6.

Install new components as necessary, PL 10.25 and PL 10.30.

6. Enter dC330 code 08-600. Check the fuser exit sensor (Q08-600). If necessary, install a new HVPS, PL 1.10 Item 3.

**NOTE:** The fuser exit sensor is mounted on the HVPS.

7. Reinstall the fuser and the exit motor. Enter dC330 code 04-200. Check that the exit motor (MOT04-200), PL 10.20 Item 4, runs and drives the fuser rolls, PL 10.15, and exit roll, PL 10.12 Item 6.
8. Check the wiring between the exit motor and CN2 on the Connection PWB. Install new components as necessary, PL 10.20 Item 4 and PL 3.10 Item 17.
9. Install new components as necessary:
  - Duplex guide, PL 10.22.
  - Connection PWB, PL 3.10 Item 17.

## 08-600 Duplex Jam 0 RAP

**08-600** The lead edge of the document failed to actuate the duplex jam 1 sensor within the correct time.

### Procedure

#### WARNING

**Switch off the electricity to the machine. Disconnect the power cord from the customer supply while performing tasks that do not need electricity. Electricity can cause death or injury. Moving parts can cause injury.**

**NOTE:** The front cover assembly interlock switch must be closed to supply +24V to the motors and clutches.

Refer to Wiring Diagram 2 and Wiring Diagram 9. Perform the following:

1. Open the rear cover assembly, PL 8.20. Remove the duplex assembly, PL 10.23, then remove all jammed paper.
2. Check the paper path for damage or obstructions.
3. Check that the duplex gate, PL 8.20 Item 9, moves freely and is not damaged.
4. Check that the duplex jam 1 sensor actuator, PL 8.25 Item 13 moves freely and is not damaged. If necessary, install a new duplex jam 1 sensor actuator, PL 8.25 Item 13.
5. Enter dC330 code 08-700. Check the duplex jam 1 sensor (Q08-700). If necessary, install a new HVPS, PL 1.10 Item 3.

**NOTE:** The duplex jam 1 sensor is mounted on the HVPS.

6. Remove the exit motor, PL 10.20 Item 4. Check the following components are clean and rotate freely:
  - a. Exit roll, PL 10.25 Item 22.
  - b. Exit roll idlers, PL 10.25 Item 3 and PL 10.25 Item 4.
  - c. Transport roll, PL 10.30 Item 6.
  - d. Transport roll idlers, PL 10.25 Item 15.Install new components as necessary, PL 10.25 and PL 10.30.
7. Reinstall the exit motor. Enter dC330 code 04-220 to run the exit motor in reverse. Check that the exit motor runs and drives the exit rolls, PL 10.20 Item 4.
8. Check the wiring between the exit motor and CN2 on the Connection PWB. Install new components as necessary, PL 10.20 Item 4, PL 3.10 Item 17.
9. Enter dC330 code 04-300 to run the duplex motor (MOT04-300), PL 10.20 Item 1. Check that the duplex drive gear, PL 10.20 Item 12 rotates.
10. Check the wiring between the duplex motor and CN7 on the Connection PWB. Install new components as necessary, PL 10.20 Item 1, PL 3.10 Item 17.
11. Manually rotate the duplex drive belt, PL 10.23 Item 12. Check that the duplex drive rolls, PL 10.23 Item 13, PL 10.23 Item 14 are clean and rotate freely. Install new components as necessary, PL 10.23.
12. Install new components as necessary:
  - Duplex assembly, PL 10.23 Item 18.
  - Connection PWB, PL 3.10 Item 17.

## 08-610 Duplex Jam 1 RAP

**08-610** The lead edge of the document failed to actuate the registration sensor after the duplex jam 1 sensor within the correct time.

### Procedure

#### WARNING

**Switch off the electricity to the machine. Disconnect the power cord from the customer supply while performing tasks that do not need electricity. Electricity can cause death or injury. Moving parts can cause injury.**

**NOTE:** The front cover assembly interlock switch must be closed to supply +24V to the motors and clutches.

Refer to Wiring Diagram 2 and Wiring Diagram 9. Perform the following:

1. Open the rear cover assembly, PL 8.20 Item 11. Remove the duplex assembly, PL 10.23 Item 18, then remove all jammed paper.
2. Check the paper path for damage or obstructions.
3. Check that the registration sensor actuator, PL 8.25 Item 14 moves freely and is not damaged. If necessary, install a new registration sensor actuator, PL 8.25 Item 14.
4. Enter dC330 code 08-500. Check the registration sensor (Q08-500). If necessary, install a new HVPS, PL 1.10 Item 3.

**NOTE:** The registration sensor is mounted on the HVPS.

5. Enter dC330 code 04-300 to run the duplex motor (MOT04-300), PL 10.20 Item 1. Check that the duplex drive gear, PL 10.20 Item 12 rotates.
6. Check the wiring between the duplex motor and CN7 on the Connection PWB. Install new components as necessary, PL 10.20 Item 12, PL 3.10 Item 17.
7. Manually rotate the duplex drive belt, PL 10.23 Item 12. Check that the duplex drive rolls, PL 10.23 Item 13, PL 10.23 Item 14 are clean and rotate freely. Install new components as necessary, PL 10.23.
8. Install new components as necessary:
  - Duplex assembly, PL 10.23 Item 18.
  - Bypass feed assembly, PL 7.10 Item 29.
  - Connection PWB, PL 3.10 Item 17.

## 08-700 Out Bin Full RAP

**08-700** The machine has detected that the exit tray is full.

### Procedure

#### WARNING

**Switch off the electricity to the machine. Disconnect the power cord from the customer supply while performing tasks that do not need electricity. Electricity can cause death or injury. Moving parts can cause injury.**

Refer to Wiring Diagram 3. Perform the following:

1. Remove all documents from the exit tray. Check that the out bin full sensor actuator, PL 10.30 Item 4 moves freely and is not damaged.
2. Enter dC330 code 08-720. Check the out bin full sensor (Q08-720), PL 10.30 Item 2.
3. Check the wiring between the out bin full sensor and CN2 on the Main PWB. If necessary, install a new out bin full sensor, PL 10.30 Item 2.
4. Enter dC330 code 04-200. Check that the exit motor (MOT04-200), PL 10.20 Item 4, runs and drives the exit roll, PL 10.25 Item 22.
5. Check the wiring between the exit motor and CN2 on the Connection PWB. Install new components as necessary, PL 10.25 Item 22, PL 3.10 Item 17.
6. If necessary install a new exit cover assembly, PL 10.30 Item 12.

## 09-100 Toner Low RAP

**09-100** The machine has detected that the print cartridge is almost empty.

### Procedure

#### WARNING

**Switch off the electricity to the machine. Disconnect the power cord from the customer supply while performing tasks that do not need electricity. Electricity can cause death or injury. Moving parts can cause injury.**

1. No immediate action is necessary. Ensure that a replacement print cartridge, PL 9.10 Item 1, is in stock.

**NOTE:** *The toner low message is based on a pixel count, not a signal from a sensor. It cannot be reset by shaking the toner cartridge.*

## 09-350 Print Cartridge Warning RAP

**09-350** The print cartridge is near the end of the design life. The design life is 10,000 print pages.

### Procedure

#### WARNING

**Switch off the electricity to the machine. Disconnect the power cord from the customer supply while performing tasks that do not need electricity. Electricity can cause death or injury. Moving parts can cause injury.**

1. No immediate action is necessary. Ensure that a replacement print cartridge, PL 9.10 Item 1, is in stock.

## 09-450 Replace Drum RAP

09-450 The print cartridge has reached the end of the design life of 10,000 print pages.

### Procedure

#### WARNING

Switch off the electricity to the machine. Disconnect the power cord from the customer supply while performing tasks that do not need electricity. Electricity can cause death or injury. Moving parts can cause injury.

1. Install a new print cartridge, PL 9.10 Item 1.

## 09-550, 820, 830 Print Cartridge Communications Error RAP

09-550 The print cartridge is not installed or is not detected by the CRUM PWB.

09-820 A non Xerox print cartridge is installed.

09-830 A mismatch detected between the CRUM and MSOK.

### Procedure

#### WARNING

Switch off the electricity to the machine. Disconnect the power cord from the customer supply while performing tasks that do not need electricity. Electricity can cause death or injury. Moving parts can cause injury.

Refer to Wiring Diagram 5. Perform the following:

1. Check that the print cartridge, PL 9.10 Item 1, is installed correctly.
2. Remove the print cartridge. Check the CRUM contact on the print cartridge.
3. Check the wiring between the print cartridge CRUM PWB, PL 9.10 Item 7 and CN17 in the Main PWB.
4. If necessary:
  - a. Install new components:
    - Print cartridge, PL 9.10 Item 1.
    - Print cartridge CRUM, PL 9.10 Item 7.
  - b. Perform OF7 Main PWB Check RAP.

## 10-100, 200 Open Fuser Error/Low Heat Error RAP

**10-100** During normal operation, the temperature of the fuser has dropped below the operating level.

**10-200** The fuser has failed to reach the correct operating temperature.

### Procedure

#### WARNING

Switch off the electricity to the machine. Disconnect the power cord from the customer supply while performing tasks that do not need electricity. Electricity can cause death or injury. Moving parts can cause injury.

#### WARNING

**Do not touch the fuser while it is hot.**

Refer to Wiring Diagram 1. Perform the following:

1. Switch off the machine, then switch on the machine.
2. Enter dC330 code 10-100 to heat the fuser to 180 degrees. Enter codes 10-200 to verify the condition of the thermistor.
3. Switch off the machine. Remove the fuser assembly. Check that the thermistor, PL 10.12 Item 16 is clean and in good contact with the fuser heat roll. Check the wiring to the thermistors. Install new components as necessary, PL 10.12 Item 16.
4. Check for continuity between the two pins on the fuser assembly connector, PL 10.12 Item 15.

**NOTE:** A cold fuser has a resistance of approximately 9 ohms (220V/240V) or 1.6 ohms (110V).

5. Check that there is continuity through the fuser heater and across the over temperature cut-out.
6. Check the wiring between the following connectors:
  - a. The fuser connector, PL 10.12 Item 15 and CON2 on the SMPS.
  - b. The fuser connector, PL 10.12 Item 15 and CN19 on the Main PWB.If necessary, install a new fuser connector, PL 10.12 Item 15.
7. If necessary:
  - a. Install new components:
    - Fuser assembly, PL 10.10 Item 1.
    - SMPS, PL 1.12 Item 3.
  - b. Perform OF7 Main PWB Check RAP.

## 10-300 Over Heat Error RAP

**10-300** The fuser temperature has risen above the normal level. Although the fuser unit can return to a normal operating temperature, the fuser may consequently be damaged.

### Procedure

#### WARNING

Switch off the electricity to the machine. Disconnect the power cord from the customer supply while performing tasks that do not need electricity. Electricity can cause death or injury. Moving parts can cause injury.

#### WARNING

**Do not touch the fuser while it is hot.**

Refer to Wiring Diagram 1. Perform the following:

1. Enter code dC330 code 10-200. Perform a fuser temperature check to verify the condition of the thermistors.
2. Switch off the machine. Remove the fuser assembly. Examine the fuser assembly for heat damage. Install new components as necessary, PL 10.10.
3. Check that the thermistor, PL 10.12 Item 16, is clean and in good contact with the fuser. Check the wiring to the thermistor. Install a new thermistor as necessary, PL 10.12 Item 16.
4. Check that there is continuity through the fuser heater and across the over temperature cut-out. If necessary, install a new thermostat assembly, PL 10.12 Item 18.
5. Check the wiring between the following connectors:
  - a. The fuser connector, PL 10.12 Item 15 and CON2 on the SMPS.
  - b. The fuser connector, PL 10.12 Item 15 and CN19 on the Main PWB.If necessary, install a new fuser connector, PL 10.12 Item 15.
6. If necessary:
  - a. Install new components:
    - Fuser assembly, PL 10.10 Item 1.
    - SMPS, PL 1.12 Item 3.
  - b. Perform OF7 Main PWB Check RAP.

## 10-500 Fuser Warning RAP

10-500 The machine has detected that the fuser assembly is near the end of its life.

### Procedure

#### WARNING

Switch off the electricity to the machine. Disconnect the power cord from the customer supply while performing tasks that do not need electricity. Electricity can cause death or injury. Moving parts can cause injury.

#### WARNING

Do not touch the fuser while it is hot.

1. No immediate action is necessary. Ensure that a replacement fuser assembly, PL 10.10 Item 1 is in stock.

## 10-510 Replace Fuser RAP

10-510 The machine has detected that the fuser assembly has reached the end of its life.

### Procedure

#### WARNING

Switch off the electricity to the machine. Disconnect the power cord from the customer supply while performing tasks that do not need electricity. Electricity can cause death or injury. Moving parts can cause injury.

#### WARNING

Do not touch the fuser while it is hot.

1. Install a new fuser assembly, PL 10.10 Item 1.

## 14-100 CCD Lock RAP

14-100 The machine has detected a mechanical fault with the CCD module.

### Procedure

#### WARNING

**Switch off the electricity to the machine. Disconnect the power cord from the customer supply while performing tasks that do not need electricity. Electricity can cause death or injury. Moving parts can cause injury.**

Refer to Wiring Diagram 3. Perform the following:

1. Raise the DADF. Check that the scanner lock, PL 14.10 Item 22 is completely unlocked.
2. Remove the scanner cover, PL 14.10 Item 20.
3. Check that the CCD module, PL 14.10 Item 8 moves freely from left to right.
4. Check the wiring between the CCD home sensor and CN5 on the Main PWB. If necessary, install a new CCD home sensor, PL 14.10 Item 4.
5. Check the wiring between the scan motor, PL 14.10 Item 10 and CN4 on the Main PWB.
6. If necessary:
  - a. Install new components:
    - Scanner motor drive assembly, PL 14.10 Item 6.
    - CCD module, PL 14.10 Item 8.
    - Scanner assembly, PL 14.10 Item 26.
  - b. Perform OF7 Main PWB Check RAP.

## 15-100 to 15-500 Scan to E-mail Faults RAP

These are the faults displayed when the machine encounters scan to e-mail problems. The faults are listed in code order, together with any recommended action. Please note that service actions are limited.

### Procedure

#### WARNING

**Switch off the electricity to the machine. Disconnect the power cord from the customer supply while performing tasks that do not need electricity. Electricity can cause death or injury. Moving parts can cause injury.**

Go to the relevant fault code and perform any service actions. If the fault is still present, perform the Final Actions.

#### 15-100 Group Name has no Assigned Email Addresses

No email address is assigned to the group name. Remove the group name from the 'To:' field or enter a valid email address.

#### 15-110 Email Send Failed

Email SMTP server returned an error during transmission. The SMTP server authentication may be supported but not enabled on the device or any 500 code is returned from the mail server. Resend the email.

#### 15-120 Invalid Recipient Email Address

The email address has either been restricted or is in the wrong format. Re-enter the email address.

#### 15-130 Mail Too Large

The machine is unable to split the mail and send it. This can occur when the machine is configured to send a maximum mail size. For example 1.0MB and the scanned mail page exceeds this size. Increase the mail size via CentreWare Internet Services. If the fault persists, increase the mail size allocation on the mail server.

#### 15-140 Invalid Email Address

The user has attempted to enter an invalid email ID. Examples are:

- Spaces in the ID
- Invalid starting character such as ',', '+', '\_', '@'
- More than one '@'

#### 15-150 Group Not Available

The user has attempted to enter an invalid group number. Confirm that the group is available and has mail addresses associated with it.

#### 15-160 Memory Full

The HDD is full during scan to email.

#### 15-170 Memory Full

The machine does not have enough memory to prepare the next job.

#### 15-200 Network Controller Error

A NIC error (SMTP). One of the following Simple Mail Transfer Protocol errors may have occurred:

- SMTP\_ENCODER\_FAILURE. Error returned by NIC during SMTP encoding activity.
- SMTP\_MEMORY\_FAILURE. Error returned by NIC for memory failure during SMTP operation.
- SMTP\_MISC\_ERROR. Miscellaneous error returned by NIC during SMTP operation.

Switch off the machine, then switch on the machine. Resend the email.

#### 15-300 Network Connection Failure

Any communication or network failure during SMTP or LDAP operations. Check the network connection. Switch off the machine, then switch on the machine.

#### 15-310 Authentication Failure

The user has attempted to enter an invalid user name or corresponding password. Enter a valid user name and password.

#### 15-320 Mail Server Connection Failure

The machine can not contact the SMTP server. Check the SMTP IP address or host name. Check that the SMTP port is open and working correctly.

#### 15-330 DNS Connection Failure

The machine cannot contact the Domain Name System to resolve the SMTP host name. Check that the DNS server is online.

#### 15-340 Mail Exceed Server Support

The maximum configured mail size exceeds the server limit. Reduce the mail size option.

#### 15-400 LDAP Communication Failure

The machine can not contact the LDAP server. Check the LDAP IP address or host name. Check that the LDAP port is correct and open.

#### 15-410 LDAP Search Failed

The LDAP server has returned an error during transmission. The LDAP server authentication may be supported but not enabled on the device or the maximum search results have been exceeded. Resend the email.

#### 15-420 LDAP Search Timeout Exceeded

The LDAP search timeout has been exceeded. Resend the email.

#### 15-430 No Matching Entries in LDAP Directory

The LDAP server cannot match the entry by user. Check the spelling of the LDAP entry, then resend the email.

#### 15-500 Session Timeout

The user has not touched a key within in the designated time frame. Resend the email.

**15-510 Scan Error**

The machine has detected an error with the scanner. Check the scanner, refer to the 14-100 CCD Lock RAP.

**15-520 Stop Pressed from MFP**

The user has cancelled the email job.

**15-600 Authentication Required**

The mail server requires user authentication to be enabled. Enable user authentication. Refer to the System Administration Guide.

**15-700 DNS Error**

The machine can not contact the DNS server or a DNS resolution failure has been detected. Check the DNS server setup or enter a valid email address.

**15-800 Pop3 Error**

The machine has detected a POP3 protocol error or an error during a POP3 session. Enter a valid email address.

**15-810 Pop3 Connection Failure**

The machine could not connect to the configured POP3 server. Check the POP3 server setup.

**15-820 Pop3 Authentication Failure**

The machine could not login into the POP3 server. Re-enter the user name and password.

**15-830 Pop3 Authentication Required**

The POP3 server requires authentication to be enabled. Enable authentication. Refer to the System Administration Guide.

**Final Actions**

Perform the OF7 Main PWB Check RAP.

## 17-100 to 610 Network Controller Faults RAP

These are the faults displayed when the machine encounters network controller problems. The faults are listed in code order, together with any recommended actions. Please note that the service actions are limited.

### Procedure

#### WARNING

**Switch off the electricity to the machine. Disconnect the power cord from the customer supply while performing tasks that do not need electricity. Electricity can cause death or injury. Moving parts can cause injury.**

Refer to Wiring Diagram 7. Go to the relevant fault code.

***NOTE:** The network connection has two LEDs positioned next to the network port. The upper LED on indicates that the PWB is ready. The lower LED flashing indicates that the network is good.*

#### 17-100 IP Address is Conflicted

The IP address of the machine is being used by another device. Go to GP 4 System Administration Tools. Check with the customer that the connectivity and network setup settings are correct.

#### 17-110 Connection Error

The machine encountered an error when establishing a connection to the designated server. Check with the customer that the connectivity and network setup settings are correct. Refer to GP 4 System Administration Tools.

#### 17-120 Server Not Found

The machine can not find the designated server. Check with the customer that the connectivity and network setup settings are correct. Refer to GP 4 System Administration Tools.

#### 17-130 Login Error

The machine can not login to the designated server. Check with the customer that the connectivity and network setup settings are correct. Refer to GP 4 System Administration Tools.

#### 17-140 Access Denied

A permissions error occurred. Check with the customer that the connectivity and network setup settings are correct. Refer to GP 4 System Administration Tools.

#### 17-150 Lock Exists

The \*.lck directory already exists.

#### 17-200 Network Cable is Disconnected

The network cable is not connected. Check the network cable.

#### 17-400 User Cancelled

The user cancelled the network scan job.

#### 17-500 Document Jam Occurred

A document jam occurred during the scan operation.

#### 17-510 Operation Error

An error occurred when sending the image file.

#### 17-600 Filename is Too Long

The name of the file to be sent is longer than the destination systems limits. Shorten the file name.

#### 17-610 Scan File Exists

The file name already exists on the destination server. Change the file name.

## 17-700 to 810 Server Error RAP

**17-700** A BOOTP server error has occurred but the automatic assigning of an IP address is working.

**17-710** A BOOTP server error has occurred and the automatic assigning of an IP address is not working.

**17-800** A DHCP server error has occurred but the automatic assigning of an IP address is working.

**17-810** A DHCP server error has occurred and the automatic assigning of an IP address is not working.

### Procedure

#### WARNING

**Switch off the electricity to the machine. Disconnect the power cord from the customer supply while performing tasks that do not need electricity. Electricity can cause death or injury. Moving parts can cause injury.**

Refer to Wiring Diagram 7. Perform the following:

1. Go to GP 4 System Administration Tools. Select Connectivity and Network Setup. Scroll to TCP / IP Settings. Disable dynamic addressing.
2. Switch off, then switch on the machine. Re-enable dynamic addressing.
3. If the fault persists, again disable dynamic addressing. Assign a new static IP address.

## 17-900 802.1X Authentication Error RAP

**17-900** The 802.1X authentication failed.

### Procedure

#### WARNING

**Switch off the electricity to the machine. Disconnect the power cord from the customer supply while performing tasks that do not need electricity. Electricity can cause death or injury. Moving parts can cause injury.**

Refer to Wiring Diagram 7. Perform the following:

1. Ensure that the 802.1X EAP type, username and password for the machine authentication switch and authentication server match.

## 20-100 to 20-900 Fax Faults RAP

These are the faults displayed when the machine encounters fax problems. The faults are listed in code order, together with any recommended actions. Please note that the service actions are limited. If the machine has a fax fault without displaying a fault code, go to the 20A Fax Faults Without a Code RAP.

### Procedure

#### WARNING

**Switch off the electricity to the machine. Disconnect the power cord from the customer supply while performing tasks that do not need electricity. Electricity can cause death or injury. Moving parts can cause injury.**

If necessary, print the embedded fax protocol report, refer to dC109.

Refer to Wiring Diagram 7. Go to the relevant fault code and perform any service actions. If the fault is still present, perform Final Actions.

#### 20-100 Communication Error

A communication failure has occurred with either the fax transmission or reception. Resend the fax.

#### 20-110 Mailbox Error

The machine is not available for mailbox communication. Go to GP 4 System Administration Tools. Check that the mailbox ID and password are correct.

#### 20-120 Scanning Error

While sending a fax using manual dial, a scanning error has occurred. Clear any jams. Switch off the machine, then switch on the machine. Resend the fax. If the fault persists, check the scanner, refer to the 14-100 CCD Lock RAP.

#### 20-200 Group Not Available

The user has selected a group location where only a single location can be used, or when the group location is unavailable. Try again, checking for the correct group location.

#### 20-300 Incompatible

The remote party does not have the feature the user has requested, for example, polling. Change the settings, then resend the fax.

#### 20-400 Line Busy

The remote party did not answer. Wait, then resend the fax.

#### 20-410 Line Error

There is a problem with the phone line, affecting transmission or reception. Try again and if necessary, wait for the line to clear.

#### 20-500 Memory Full

The fax data memory is full. Delete any unnecessary documents awaiting transmission, or wait until more memory becomes available, or split the current Fax in to smaller units.

#### 20-550 Low Memory

The available fax memory is getting low.

#### 20-600 No Answer

It has not been possible to connect to the remote fax, even after re-dial attempts. Check that the remote fax is on line and try again.

#### 20-700 Number Not Assigned

No number has been assigned for the speed dial location selected. Assign a number to this location or dial the number manually.

#### 20-800 Power Failure

During a power-off period, the machine has lost its user memory. Check that the backup battery is holding its charge of about +3V. If necessary, install a new battery. Wait, then resend the fax.

#### 20-900 Retry Redial

This indicates that the machine is waiting to re-dial. Press **Start** to re-dial immediately, or press **Stop** to cancel the re-dial procedure.

#### Final Actions

Perform the following:

1. Install a new fax PWB, PL 3.10 Item 3:
2. Perform the OF7 Main PWB Check RAP.

## 20A Fax Faults Without a Code RAP

Use this RAP when the machine has a fax fault but does not display a code. If a fax fault code is displayed, go to the 20-100 to 20-900 Fax Faults RAP.

### Procedure

#### WARNING

**Switch off the electricity to the machine. Disconnect the power cord from the customer supply while performing tasks that do not need electricity. Electricity can cause death or injury. Moving parts can cause injury.**

Refer to Wiring Diagram 7. Perform the following:

1. Ensure the telephone line cable is properly connected into the line connector on the Fax PWB module, PL 3.10 Item 3.
2. Ensure the correct dialing mode is selected. Refer to GP 4 System Administration Tools.
3. Use a known good telephone handset or a line test tool to check the telephone line.
4. If sent faxes are blank or light, make sure that the scanner lock is completely unlocked.
5. If necessary install a new fax PWB, PL 3.10 Item 3.
6. Perform OF7 Main PWB Check RAP.

# OF1 Audible Noise RAP

Use this RAP to isolate and identify the source of unusual noises.

## Procedure

### WARNING

**Switch off the electricity to the machine. Disconnect the power cord from the customer supply while performing tasks that do not need electricity. Electricity can cause death or injury. Moving parts can cause injury.**

1. Ask the customer if there are any specific machine functions that are noisy.
2. Identify the source of the noise by exercising the machine in all modes.
3. Use diagnostics to run individual components.
4. Go to the relevant subsection:
  - Main Drives and Paper Transport
  - LSU
  - DADF
  - Tray 2
5. Refer to Possible Causes and Potential Solutions.

### Main Drives and Paper Transport

- Enter dC330 code 04-100 to run the main BLDC motor. The following components will be run.
  - The print cartridge, PL 9.10 Item 1.
  - The registration roll PL 8.25 Item 3.
  - The registration roll idler PL 8.25 Item 17.
- While the main BLDC motor runs, stack the code 08-810 to energize the tray 1 pickup solenoid and run the tray 1 pickup roll, PL 10.22 Item 14 and feed roll, PL 10.22 Item 9.
- While the main BLDC motor runs, stack the code 08-850 to energize the registration solenoid and run the registration roll, PL 8.25 Item 3 and registration roll idler, PL 8.25 Item 17.
- While the main BLDC motor runs, stack the code 08-800 to energize the bypass feed solenoid and run the bypass pickup roll, PL 7.10 Item 28.
- Enter dC330 code 04-300 to run the duplex motor. The duplex rolls, PL 10.23 Item 13 and PL 10.23 Item 14, will rotate.
- Enter dC330 code 04-200 to run the exit motor. The following fuser components will be run:
  - The heat roll in the fuser, PL 10.15 Item 1.
  - The pressure rolls in the fuser, PL 10.15 Item 2 and PL 10.15 Item 3.
  - Exit roll, PL 10.25 Item 22.
- Enter dC330 code 04-120 to run the main fan, PL 1.12 Item 9.
- Enter dC330 code 10-500 to run the fuser fan, PL 10.20 Item 2.
- Enter dC330 code 09-500 to run the SMPS fan, PL 1.12 Item 1.

### LSU

- Enter dC330 code 06-100 to run the LSU motor.

### DADF

- Enter dC330 code 05-200 to run the scan motor, PL 14.10 Item 10, in the DADF.

The following components will be run:

- Scan roll, PL 5.35 Item 12.
- Exit roll, PL 10.25 Item 22.
- While the scan motor runs, stack the code 05-300 to energize the pickup solenoid and run the DADF pickup roll assembly PL 5.25 Item 2.
- While the DADF scan motor runs, stack the code 05-310 to energize the registration solenoid and run the registration roll, PL 5.35 Item 9.

### Tray 2

- Enter dC330 code 07-210 to run the tray 2 feed motor, PL 8.15 Item 23. The tray 2 feed roll, PL 8.17 Item 12, will rotate.
- While the tray 2 feed motor runs, stack the code 08-820 to energise the tray 2 pickup solenoid and run the tray 2 pickup roll assembly PL 8.17 Item 31.

## Possible Causes and Potential Solutions

Go to the relevant procedure:

- Squeaks
- Unusual Noise from the Scanner Assembly

### Squeaks

Possible causes are:

- Contamination of the bushes and drive shafts.

Solution:

- Clean the components.
- Plastic bushes should be cleaned and lubricated.
- Install new components as necessary.

- Bearings in cooling fans

Solution:

- Install new components as necessary.

- Mis-adjusted or worn drive belts.

Solution:

- Install new components as necessary.
  - Mis-aligned or damaged parts.
- Solution:
- Check for parts that are damaged or out of position.
  - Adjust the components if appropriate.
  - Install new components as necessary.

- Noise from the DADH input tray document guides.

Solution:

- Clean the DADH input tray in the area beneath the input guides.

### Unusual Noise from the Scanner Assembly

Possible causes are:

- Mis-aligned or damaged parts.
- Defective motor driver.

Solution:

- Check the position of the scan motor and associated gears, PL 14.10.
- Ensure the CCD module, PL 14.10 Item 8, moves freely.

- Install new components as necessary, PL 14.10.

## OF2 UI Touch Screen Error RAP

Use this RAP to solve UI touch screen problems when the machine has power but either the display is missing, is too dark or the UI screen responds incorrectly or does not refresh.

### Procedure

#### WARNING

**Switch off the electricity to the machine. Disconnect the power cord from the customer supply while performing tasks that do not need electricity. Electricity can cause death or injury. Moving parts can cause injury.**

Refer to Wiring Diagram 4. Perform the following:

1. If possible, enter dC305 UI test. Perform the relevant tests to check the operation of the UI.
2. Remove the UI, refer to REP 2.1. Check the ribbon cables between the UI PWB and the touch screen, PL 2.10.
3. Check the following wiring:
  - Between CN2 on the UI PWB and CN6 on Main PWB.
  - Between CN1 on the UI PWB and CN11 on Main PWB.
  - Between CN11 on the UI PWB and CN10 on Main PWB.
4. If necessary:
  - a. Install new components:
    - Touch screen, PL 2.10 Item 25.
    - UI assembly, PL 2.10 Item 27.
  - b. Perform OF7 Main PWB Check RAP.

## OF3 Air Systems RAP

Use this RAP to diagnose faulty machine fans. Faulty fans can cause image quality defects, odours or overheating.

### Procedure

#### WARNING

**Switch off the electricity to the machine. Disconnect the power cord from the customer supply while performing tasks that do not need electricity. Electricity can cause death or injury. Moving parts can cause injury.**

Check the following fans:

- SMPS Fan
- Main Fan
- Fuser Fan

#### SMPS Fan

Refer to Wiring Diagram 9. Perform the following:

1. Switch off the machine, then switch on the machine.
2. Enter dC330 code 09-500. Check that the SMPS fan, PL 1.12 Item 1 runs at normal speed.
3. Check the wiring between the SMPS fan and CN8 on the Connection PWB.
4. Install new components as necessary:
  - SMPS fan, PL 1.12 Item 1.
  - Connection PWB, PL 3.10 Item 17.

#### Main Fan

Refer to Wiring Diagram 9. Perform the following:

1. Switch off the machine, then switch on the machine.
2. Enter dC330 code 04-120. Check that the main fan, PL 1.12 Item 9 runs at normal speed.
3. Check the wiring between the main fan and CN1 on the Connection PWB.
4. Install new components as necessary:
  - Main fan, PL 1.12 Item 9.
  - Connection PWB, PL 3.10 Item 17.

#### Fuser Fan

Refer to Wiring Diagram 9. Perform the following:

1. Switch off the machine, then switch on the machine.
2. Enter dC330 code 10-500. Check that the fuser fan, PL 10.20 Item 2 runs at normal speed.
3. Check the wiring between the fuser fan and CN2 on the Connection PWB.
4. Install new components as necessary:
  - Fuser fan, PL 10.20 Item 2.
  - Connection PWB, PL 3.10 Item 17.

## OF4 Copying Error RAP

Use this RAP if the machine does not copy correctly when the customer uses features such as auto size detect, edge erase, book copying and image shift.

### Procedure

#### WARNING

**Switch off the electricity to the machine. Disconnect the power cord from the customer supply while performing tasks that do not need electricity. Electricity can cause death or injury. Moving parts can cause injury.**

1. Perform the Scan Edge Print test, GP 18.
2. If the test fails, clean the document glass.
3. If necessary, install a new scanner cover, PL 14.10 Item 20.

## OF5 Stapler Fault RAP

Use this RAP if the stapler fails to operate.

### Procedure

#### WARNING

**Switch off the electricity to the machine. Disconnect the power cord from the customer supply while performing tasks that do not need electricity. Electricity can cause death or injury. Moving parts can cause injury.**

Refer to Wiring Diagram 9.

1. Check the stapler door interlock switch, go to 01-700 Stapler Door Open RAP.
2. Check the wiring between CON1 on the stapler and CN4 on the Connection PWB.
3. Open the stapler door, PL 28.10 Item 9. Check that the paper present switch actuator moves freely and actuates the paper present switch.
4. Install new components as necessary:
  - Stapler, PL 11.10 Item 3.
  - Connection PWB, PL 3.10 Item 17.

## OF6 Unable to Boot RAP

Use this RAP if the machine powers up but fails to boot.

### Procedure

#### WARNING

**Switch off the electricity to the machine. Disconnect the power cord from the customer supply while performing tasks that do not need electricity. Electricity can cause death or injury. Moving parts can cause injury.**

Perform the following:

1. Switch off the machine, then switch on the machine.
2. Check the memory DIMM, PL 3.10 Item 10 is correctly installed.
3. If necessary:
  - a. Install new components:
    - Memory DIMM, PL 3.10 Item 10.
    - Hard disk drive, PL 3.10 Item 16.
  - b. Perform OF7 Main PWB Check RAP.

## OF7 Main PWB Check RAP

Use this RAP to check the main PWB. This RAP must be performed before a new main PWB is installed.

### Procedure

#### WARNING

**Switch off the electricity to the machine. Disconnect the power cord from the customer supply while performing tasks that do not need electricity. Electricity can cause death or injury. Moving parts can cause injury.**

Perform the PWB Checks.

### PWB Checks

The following steps are used to diagnose a fault with the input voltage to the main PWB or output voltage from the main PWB.

Perform the following:

1. Ensure the supply voltage is within specification, refer to GP 7 Machine Specifications. If possible, connect the machine directly to a known good power supply. If possible, do not connect the machine to a multiway connector or power strip that is being used to supply power to other electro-mechanical devices. Card readers, printers and PC's are known to cause problems for Xerox equipment if they share a power supply.  
If the customer's power supply is faulty, inform the customer.
2. Refer to Wiring Diagram 6. Disconnect CN26 from the Main PWB. Check the output voltage from the connection PWB PL 3.10 Item 17. If necessary, install a new connection PWB. If the output voltage from the connection PWB is good, reconnect CN26. Check the voltage on the main PWB. Repair the wiring as necessary.
3. Refer to Wiring Diagram 2, Wiring Diagram 3, Wiring Diagram 5 and Wiring Diagram 7. Actuate each component connected to the main PWB. Check that the signal voltage from each component changes state. Check the wiring or install new components as necessary.
4. Check all connectors on the main PWB. If necessary, remove any oxidation from the pins and connectors.
5. If the fault is still present, perform the Software Checks.

### Software Checks

The following steps are used to clear any memory or software faults. The customer's settings will be reset to default. Ensure all customer data is recorded before clearing the memory.

Perform the following:

1. Print the System Configuration and Fax Phone Book (TBD) reports, refer to GP 5. Enter dC132. Initialize the Copier NVM, Network NVM and Fax Card NVM.
2. Reinstall the machine firmware, refer to GP 6 Firmware Upgrade.
3. If the fault is still present, perform the Final Actions.

### Final Actions

Perform the following:

1. Install a new main PWB PL 3.10 Item 6.
2. Perform GP 15 Shading Test.

## 3 Image Quality RAPs

### Image Quality RAPs

IQ1 Image Quality Entry RAP .....	3-3
IQ2 Blank Copies RAP .....	3-8
IQ3 Black Copies or Prints RAP .....	3-9
IQ4 Blurred Image From the Scanner RAP .....	3-9
IQ5 Vertical Black Lines or Bands RAP .....	3-10
IQ6 Vertical White Lines RAP .....	3-10
IQ7 Light Image RAP .....	3-11
IQ8 Dark Image RAP .....	3-12
IQ9 Background RAP .....	3-12
IQ10 Ghost Images RAP .....	3-13
IQ11 Stains on Back of Paper RAP .....	3-14
IQ12 Poor Fusing RAP .....	3-14
IQ13 Partial Blank Image (Not Periodic) RAP .....	3-15
IQ14 Partial Blank Image (Periodic) RAP .....	3-15
IQ15 Different Image Density (Left and Right) RAP .....	3-16
IQ16 Horizontal Bands RAP .....	3-16
IQ17 Periodic Printing Defects Check RAP .....	3-17
IQ18 DADF Lead Edge Offset RAP .....	3-18
IQ19 Poor Registration RAP .....	3-18

### Image Quality Specifications

IQS 1 Solid Area Density .....	3-19
IQS 2 Skew .....	3-20
IQS 3 Registration .....	3-20

## IQ1 Image Quality Entry RAP

Use this RAP to determine the source of an image quality problem.

### Initial Actions

- Check the condition of the paper. Do not use incorrectly cut paper, damp paper, paper with rough edges, badly drilled paper, paper with wrapper wax or glue. Paper and media should be stored flat, enclosed in wrappers, in a cool dry environment.
- Check that the paper is within specifications. Refer to GP 9 Paper and Media Specifications.
- Check that paper tray guides are set to the correct paper size.
- Check the document guides on the DADF.
- Check the original documents for defects.
- Ensure that the image adjustment mode selections are those used by the customer.
- Check that the machine fans are working, go to the OF3 Air Systems RAP.

### Procedure

If necessary, refer to IQ1 Internal Test Patterns for:

- A description of image quality defects.
- The optimum test pattern to be used to diagnose the defect.
- An example of all internal test patterns.

If possible, use the customer job to recreate the image quality problem.

Enter dC606. Select a suitable test pattern. Select the Features, 1 or 2 sided and paper size. Press Start Test. Go to the relevant RAP:

- IQ2 Blank Copies RAP
- IQ3 Black Copies or Prints RAP.
- IQ4 Blurred Image From the Scanner RAP
- IQ5 Vertical Black Lines or Bands RAP
- IQ6 Vertical White Lines RAP
- IQ7 Light Image RAP
- IQ8 Dark Image RAP
- IQ9 Background RAP
- IQ10 Ghost Images RAP
- IQ11 Stains on Back of Paper RAP
- IQ12 Poor Fusing RAP
- IQ13 Partial Blank Image (Not Periodic) RAP
- IQ14 Partial Blank Image (Periodic) RAP
- IQ15 Different Image Density (Left and Right) RAP
- IQ16 Horizontal Bands RAP
- IQ17 Periodic Printing Defects Check RAP
- IQ18 DADF Lead Edge Offset RAP
- IQ19 Poor Registration RAP.

## IQ1 Internal Test Patterns

Table 1 defines the image defect, gives a description of the defect and identifies the optimum test pattern to be used.

**NOTE:** There are 19 internal test patterns, but only 7 are unique. Each test pattern is available more than one time. Only the first occurrence of a test pattern is shown in Table 1.

Table 2 describes the test patterns and the purpose for which they should be used to identify image quality defects.

**Table 1 Image quality defects**

Image quality defect	Description of defect	Optimum internal test pattern
Background	Uniform darkening across all the non print areas	1
Bands	Grey to dark in the light or non-image areas of the print in the process direction or across the process direction. See also narrow bands.	1
Beads on print	Developer beads in the light or non-image areas of the print.	1, 7, 8
Black image	A print that is black or grey all over, but has no visible image of the original document.	1, 7, 8
Blank image	No visible image.	1, 7, 8
Blurred image	Part or whole of the image has the appearance of being out of focus.	1, 7, 8
Dark prints	Very dark background with a visible image.	1, 7, 8
Deletions	Areas of the image missing from the print. Deletions may be in the form of white spots, marks, lines, or whole areas of toner missing from the print.	1, 6
Displaced and fragmented image	Distorted images, part images and missing images (scrambled images). Displaced images.	1
Light image	The image is visible on the print, but with insufficient solid area density.	1
Lines	Black or white lines across the process direction or in the process direction. See also the description, displaced and fragmented image.	1, 7
Magnification	At 100% magnification the printed image differs from the size of the image on the original document.	7
Marks	Dark marks in the non-image areas of the print.	1, 7
Misregistration	The image on the paper is misregistered.	7
Narrow Bands	Bands across the process direction visible in halftone areas.	1, 4, 5
Non uniformity	Variation in image quality and density across the print. See also uneven density.	4, 5
Offsetting	A previous image that was not removed from the fuser roll during the cleaning cycle. The image is repeated at regular intervals.	1, 5

**Table 1 Image quality defects**

Image quality defect	Description of defect	Optimum internal test pattern
Part images and missing images	Incomplete or missing images.	1
Print damage	Creases, curl, cuts, folds, wrinkles, or embossed marks are visible on the print.	1, 3, 4, 5, 6, 8
Repeat images	Refer to offsetting defects and residual image defects.	1, 5
Residual image	A previous image that was not removed from the photoreceptor during the cleaning cycle.	1, 5
Skew	A difference in angular alignment between image on the print and the original document.	7
Skips	Loss or stretching of the image, and compression of the image, in bands across the process direction.	1
Smears	Loss or stretching of the image, and compression of the image, in bands across the process direction.	1, 3
Smudges	Darker images across the process direction.	1
Spots	Dark spots in the non-image areas of the print.	Make a blank copy
Streaks	Lines on the print, in the process direction of the non-image area.	1, 7, 8
Stretched and distorted images	The image on the paper is stretched or distorted.	1
Toner contamination on the back of prints	Random black spots or marks	Make a blank copy
Uneven density	Variation in image density across the print. See also non uniformity.	1
Unfused prints	The toner image on the finished print is not fused to the print medium.	6

**Table 2 Internal test patterns**

Number	Description	Purpose
1	S600 pattern (A4), Figure 1.	Light density uniformity, deletions, lines, bands, streaks, smears, solid area reproducibility, motion quality (LSU).
2	S600 pattern (8.5 x 11), Figure 1.	Light density uniformity, deletions, lines, bands, streaks, smears, solid area reproducibility, motion quality (LSU).
3	Grey dusting pattern (8.5 x 11), Figure 2.	Print damage.
4	Grey dusting pattern with border, Figure 3.	Print damage.
5	Ghosting pattern (8.5 x 11), Figure 4.	Ghost imaging, fuser offset, print damage.
6	Dark dusting (duplex), Figure 5.	Fix, white lines, white spots.
7	Skew test (11 duplex), Figure 6.	Lead edge registration, side edge registration, skew, magnification.
8	Character test pattern (duplex), Figure 7.	Light density uniformity, deletions, lines, bands, streaks, smears, solid area reproducibility, motion quality (LSU), print damage.
9	S600 pattern (A4 duplex), Figure 1.	Light density uniformity, deletions, lines, bands, streaks, smears, solid area reproducibility, motion quality (LSU).
10	S600 pattern (8.5 x 11 duplex), Figure 1.	Light density uniformity, deletions, lines, bands, streaks, smears, solid area reproducibility, motion quality (LSU).
11	Grey dusting pattern (8.5 x 11 duplex), Figure 2.	Skips, smears, print damage.
12	Grey dusting pattern with border (8.5 x 11 duplex), Figure 3.	Print damage.
13	Ghosting pattern (duplex), Figure 4.	Ghost imaging, fuser offset.
14	Dark dusting (duplex), Figure 5.	Fix, white lines, white spots.
15	Skew test (duplex), Figure 6.	Lead edge registration, side edge registration, skew, magnification.
16	Character test pattern (duplex), Figure 7.	Light density uniformity, deletions, lines, bands, streaks, smears, solid area reproducibility, motion quality (LSU), print damage.
17	S600 pattern (A4 duplex), Figure 1.	Light density uniformity, deletions, lines, bands, streaks, smears, solid area reproducibility, motion quality (LSU).
18	S600 pattern (8.5 x 11 duplex), Figure 1.	Light density uniformity, deletions, lines, bands, streaks, smears, solid area reproducibility, motion quality (LSU).
19	Grey dusting pattern (duplex), Figure 2.	Skips, smears, print damage.

Table 2 Internal test patterns

Number	Description	Purpose
N/A	Blank copy	0% area coverage. Background defects, black spots, black lines, scratches, beads.

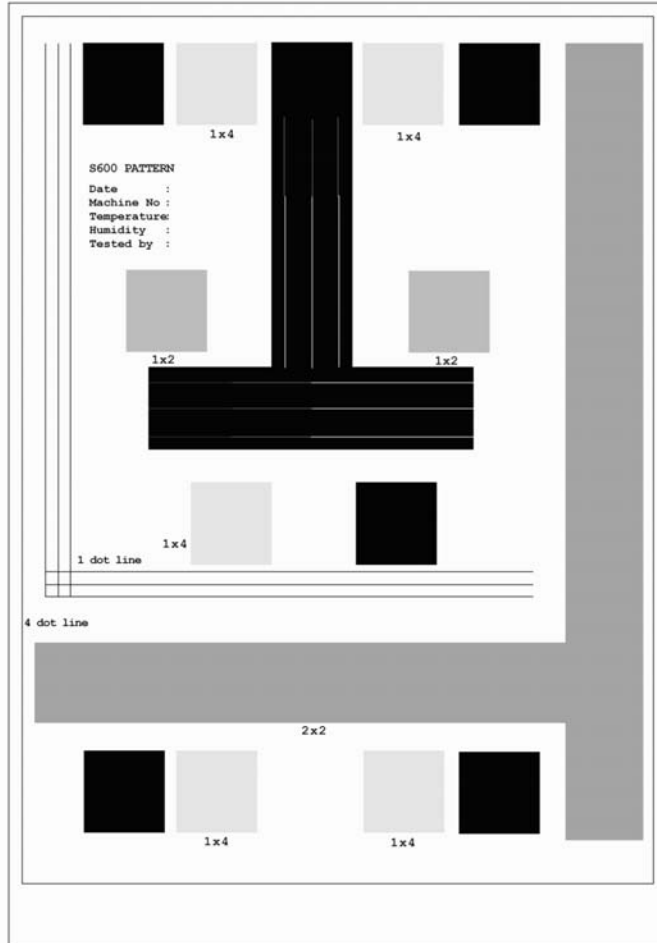

AP-1-1507-A

Figure 1 Test pattern 1, 2, 9, 10, 17 and 18

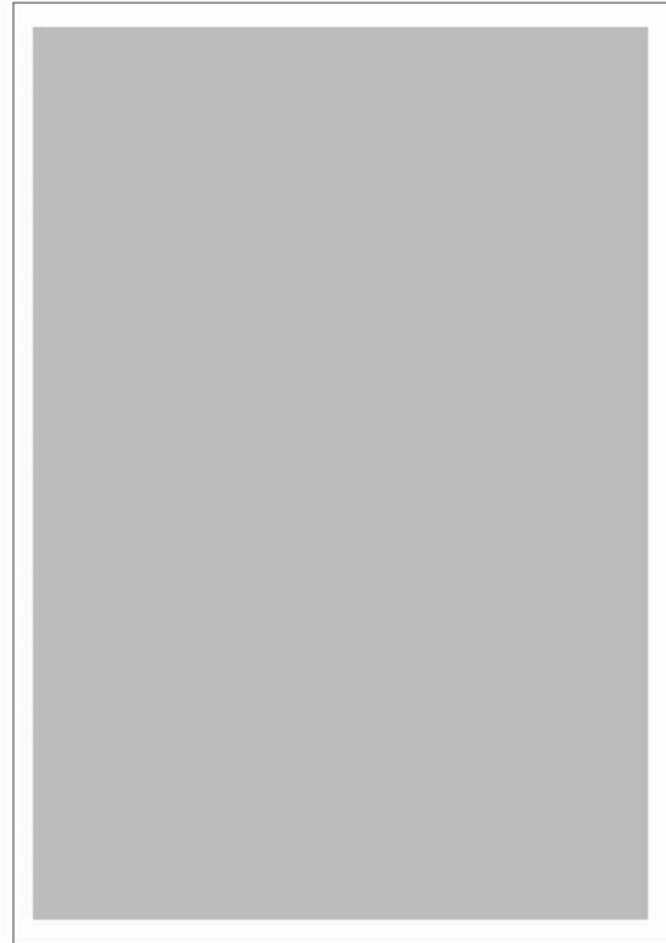

AP-1-1508-A

Figure 2 Test pattern 3, 11 and 19

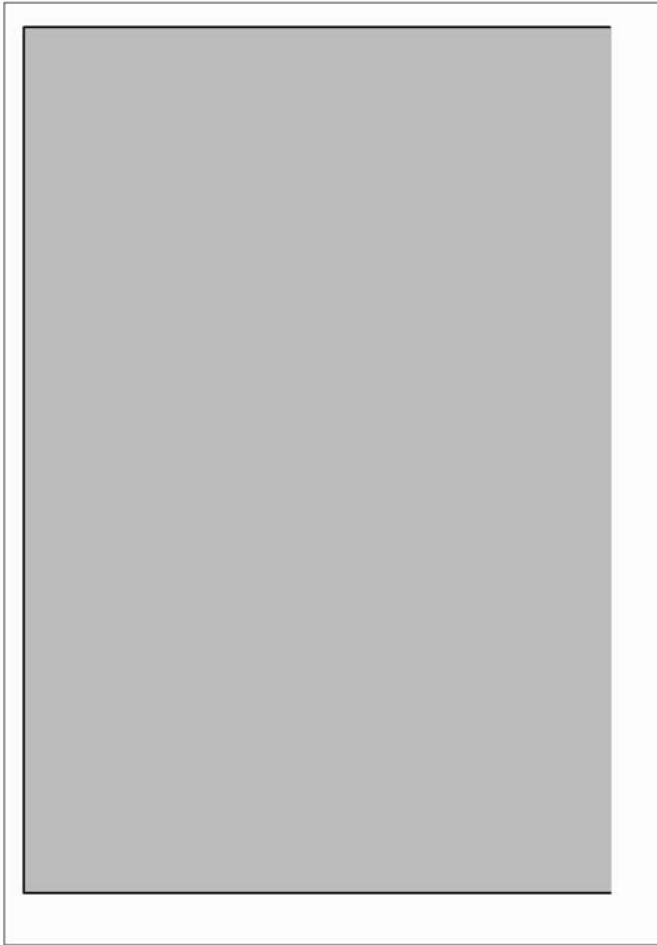

AP-1-1509-A

Figure 3 Test pattern 4 and 12

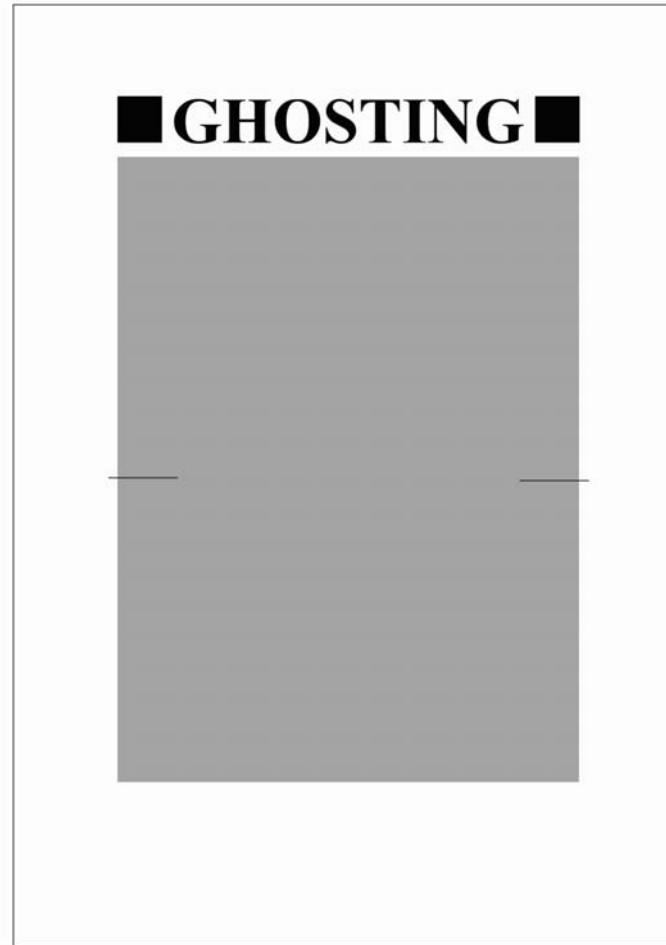

AP-1-1510-A

Figure 4 Test pattern 5 and 13

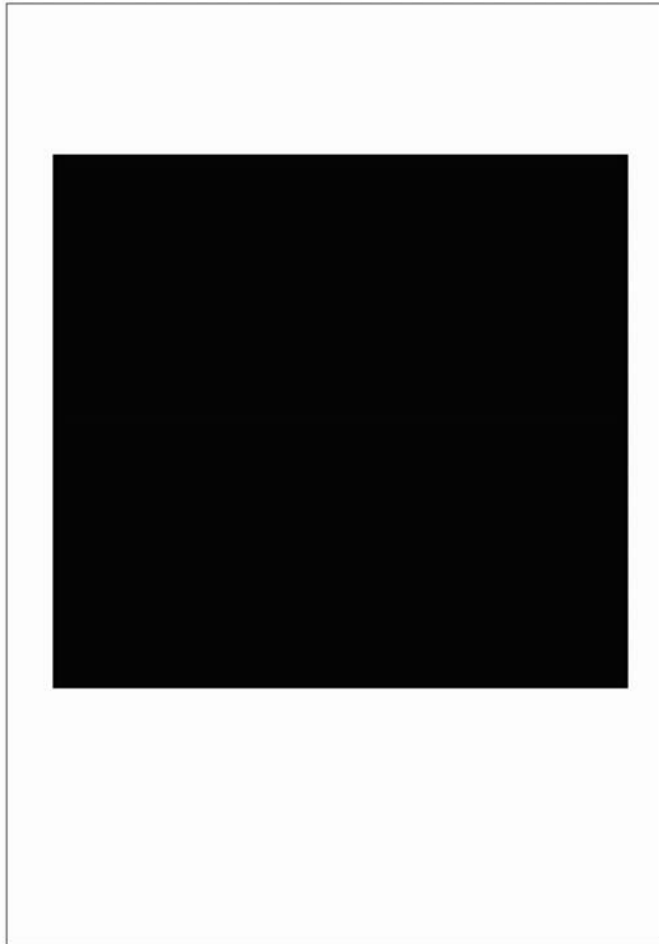

AP-1-1511-A

Figure 5 Test pattern 6 and 14

<p>Normal dimensions:          LE Registration = 12.7mm          SE (Left)Registration = 12.7mm          Line BH = 241.3mm          Line DF = 177.8mm</p>		<p>LEAD EDGE (TOP)          PAPER SIZE FROM TRAY 1          APOLLO SKEW TEST          MACHINE #:          DATE:          PRINT COUNT:</p>
<p>MEASUREMENT DATA:          Lead Edge Registration: _____ mm          Side Edge Registration: _____ mm          Skew: _____ mm          Vertical Magnification: _____ %          Horizontal Magnification: _____ %</p>		
<p>Measurement Procedure:          1. LE Registration: Distance in mm from B to the paper Lead Edge.          2. Side Edge Registration: Distance in mm from d to paper left edge.          3. Skew: (Distance from left vertical line to paper edge in mm at A) - (Distance from left vertical line to paper edge in mm at G)          4. Vertical Magnification: ((Length of B-H in mm) / 241.3) x 100          5. Horizontal Magnification: ((Length of D-F in mm) / 177.8) x 100          Notes:          - Keep the sign intact for 1., 2. and 3.</p>		

AP-1-1512-A

Figure 6 Test pattern 7 and 15

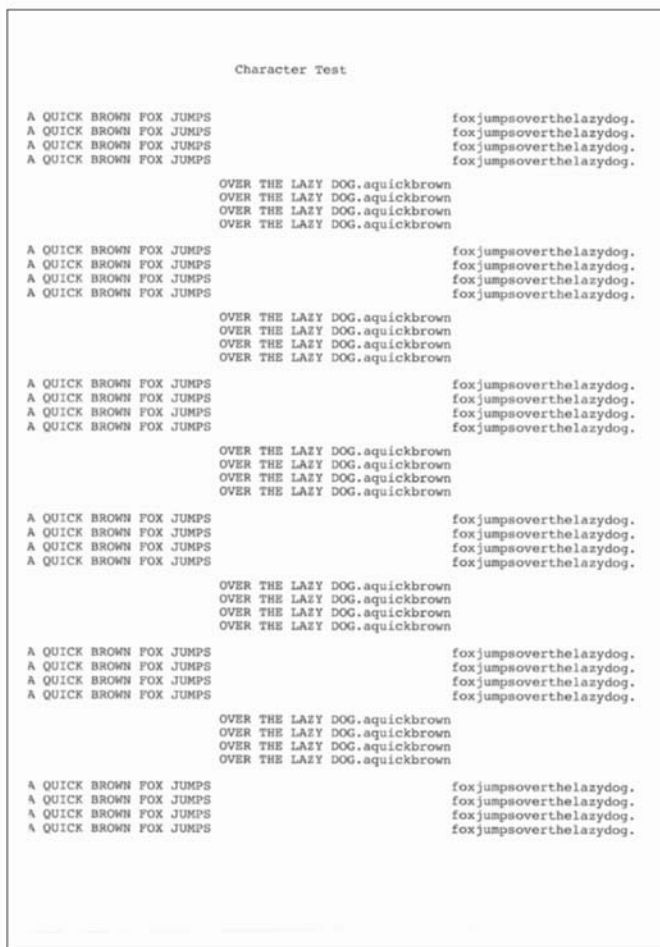

AP-1-1513-A

Figure 7 Test pattern 8 and 16

## IQ2 Blank Copies RAP

Use this RAP when the machine produces blank copies.

### Procedure

### WARNING

**Switch off the electricity to the machine. Disconnect the power cord from the customer supply while performing tasks that do not need electricity. Electricity can cause death or injury. Moving parts can cause injury.**

1. Determine the source of the problem. Make a print. Make a copy.
  2. If the fault appears only in copy mode, perform the following:
    - a. Ensure the DADF is closed. Room illumination can be transmitted through thin originals.
    - b. If the fault appears only when using the DADF, check that the scanner lock, PL 14.10 Item 22 is completely unlocked.
    - c. Perform the Shading Test procedure, GP 15. If the shading test fails:
      - i. Install new components as necessary:
        - CCD module, PL 14.10 Item 8.
        - CCD module cable, PL 14.10 Item 23.
        - Scanner assembly, PL 14.10 Item 26.
      - ii. Perform OF7 Main PWB Check RAP.
  3. If the fault appears in all modes, perform the following:
    - a. Examine the print cartridge, PL 9.10 Item 1. Ensure it is free from all packing or sealing material.
    - b. Check the LSU. Go to the 06-100, 06-200 LSU Error RAP.
    - c. Refer to Wiring Diagram 5. Perform the following:
      - Check the wiring between the LSU and CN24 on the Main PWB.
      - Install a new LSU, PL 6.10 Item 1.
    - d. Perform the following:
      - Refer to Wiring Diagram 2. Check the spring contacts between the HVPS PL 1.10 Item 3 and the print cartridge PL 9.10 Item 1. The spring contacts supply the voltages to the print cartridge. If necessary, clean the spring contacts.
      - Check the following wiring:
        - Wiring Diagram 1. Between CON3 on the SMPS and the CN6 on the Connection PWB.
        - Wiring Diagram 2. Between CN31 on the Main PWB and CN5 on the HVPS.
        - Wiring Diagram 6. Between CN5 on the Connection PWB and CN26 on the Main PWB.
    - e. Install new components as necessary:
      - HVPS, PL 1.10 Item 3.
      - Connection PWB, PL 3.10 Item 17.
      - Print cartridge, PL 9.10 Item 1.
- Perform OF7 Main PWB Check RAP.

## IQ3 Black Copies or Prints RAP

Use this RAP when the machine produces black copies and prints.

### Procedure

#### WARNING

**Switch off the electricity to the machine. Disconnect the power cord from the customer supply while performing tasks that do not need electricity. Electricity can cause death or injury. Moving parts can cause injury.**

Refer to Wiring Diagram 3. Perform the following:

1. Make a print, make a copy. If the print and copy are both black, go to the 06-100, 06-200 LSU Error RAP.
2. Check the CCD module cable, PL 14.10 Item 23, between the CCD module and CN3 on the Main PWB. If necessary, install a new CCD module cable, PL 14.10 Item 23.
3. If necessary install a new CCD module, PL 14.10 Item 8.
4. Perform OF7 Main PWB Check RAP.
5. Refer to Wiring Diagram 2. Perform the following:
  - Check the spring contacts between the HVPS, PL 1.10 Item 3, and the print cartridge, PL 9.10 Item 1. The spring contacts supply the voltages to the print cartridge. If necessary, clean the spring contacts.
  - If necessary, install a new HVPS, PL 1.10 Item 3.

## IQ4 Blurred Image From the Scanner RAP

Use this RAP when the scanner produces blurred images.

### Procedure

#### WARNING

**Switch off the electricity to the machine. Disconnect the power cord from the customer supply while performing tasks that do not need electricity. Electricity can cause death or injury. Moving parts can cause injury.**

1. Check the gap between the pressure plate and the CVT glass. Perform the following:

- a. Put a sheet of A4 or 8.5x11 inch paper over the CVT glass, PL 14.10.
- b. Close the DADF.
- c. Carefully pull the paper from underneath the DADF. Make sure that the paper was pressed between the pressure plate and the CVT glass. If necessary, install a new DADF PL 5.10.

2. Perform the Shading Test procedure, GP 15. If the shading test fails:

- a. Install new components as necessary:
  - CCD module, PL 14.10 Item 8.
  - CCD module cable, PL 14.10 Item 23.
  - Scanner assembly, PL 14.10.
- b. Perform OF7 Main PWB Check RAP.

## IQ5 Vertical Black Lines or Bands RAP

Use this RAP when there are black lines or bands along the process direction, as shown in Figure 1.



AP-1-1514-A

Figure 1 Vertical black line and band

### Procedure

#### WARNING

**Switch off the electricity to the machine. Disconnect the power cord from the customer supply while performing tasks that do not need electricity. Electricity can cause death or injury. Moving parts can cause injury.**

1. If the defect is only present on received faxes, ensure the defect is not being generated by the fax machine that is transmitting the fax.
2. If the defect is only present when making copies, clean the document glass.
3. If the defect is only present when making copies from the DADF, clean the CVT glass.
4. Lightweight media can cause fusing problems that may result in vertical lines. Ensure the customer is using media that is within specification. Refer to GP 9 Paper and Media Specifications.
5. The fuser may be contaminated. Make 10 blank copies. Install new components as necessary, PL 10.10, PL 10.12 and PL 10.15.
6. Refer to Wiring Diagram 5. Check that the harness between the LSU and CN24 Main PWB is correctly and securely connected.
7. Install new components as necessary:
  - Print cartridge, PL 9.10 Item 1.
  - LSU, PL 6.10 Item 1.

## IQ6 Vertical White Lines RAP

Use this RAP when there are white lines along the process direction, as shown in Figure 1.



AP-1-1515-A

Figure 1 Vertical white lines

### Procedure

#### WARNING

**Switch off the electricity to the machine. Disconnect the power cord from the customer supply while performing tasks that do not need electricity. Electricity can cause death or injury. Moving parts can cause injury.**

1. Remove the print cartridge, PL 9.10 Item 1. Ensure there are no obstructions that block the LSU from imaging the print cartridge.
2. Remove the LSU, PL 6.10 Item 1. Clean the LSU window using a clean, lint-free cloth. If necessary, install a new LSU, PL 6.10 Item 1.
3. Install a new print cartridge, PL 9.10 Item 1.

## IQ7 Light Image RAP

Use this RAP when the machine produces light images in all modes, as shown in Figure 1.

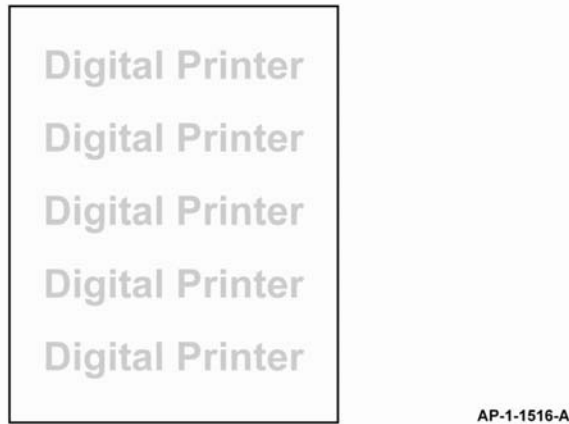

Figure 1 Light image

- Check the spring contacts between the HVPS PL 1.10 Item 3 and the print cartridge PL 9.10 Item 1. The spring contacts supply the voltages to the print cartridge. If necessary, clean the spring contacts.
  - If necessary, install a new HVPS, PL 1.10 Item 3.
7. Refer to Wiring Diagram 2. Check the wiring between CN5 on the HVPS and CN31 on the Main PWB.
  8. Check the spring contact from the HVPS to the transfer roll, PL 9.10 Item 2. If necessary, clean the spring contact. Install new components as necessary, PL 9.10.
  9. Refer to Wiring Diagram 5. Check the wiring between the 3 thermistors and CN16 on the Main PWB. Light copies can be caused by a faulty thermistor. Install new components as necessary:
    - Thermistor 1, 2 or 3 PL 10.25 Item 5.
  10. Install new components as necessary:
    - HVPS, PL 1.10 Item 3.
    - Print cartridge, PL 9.10 Item 1.

### Procedure

#### WARNING

Switch off the electricity to the machine. Disconnect the power cord from the customer supply while performing tasks that do not need electricity. Electricity can cause death or injury. Moving parts can cause injury.

**NOTE:** For solid print area specifications, refer to IQS 1 Solid Area Density.

Perform the following:

1. If the fault appears only in copy mode when using the DADF, check that the scanner lock, PL 14.10 Item 22 is completely unlocked.
2. Ensure that the paper tray settings match the paper or media size in the trays.
3. Examine the print cartridge, PL 9.10 Item 1. Ensure that it is free from all packing or sealing material.
4. Perform the Shading Test procedure, GP 15. If the shading test fails:
  - a. Install new components as necessary:
    - CCD module, PL 14.10 Item 8.
    - CCD module cable, PL 14.10 Item 23.
    - Scanner assembly, PL 14.10 Item 26.
    - Main PWB, PL 3.10 Item 6.
  - b. Perform OF7 Main PWB Check RAP.
5. Remove the LSU, PL 6.10 Item 1. Clean the LSU window using a clean, lint-free cloth. If necessary, install a new LSU, PL 6.10 Item 1.
6. Refer to Wiring Diagram 2. Perform the following:

## IQ8 Dark Image RAP

Use this RAP when the machine produces dark images in all modes.

### Procedure

#### WARNING

**Switch off the electricity to the machine. Disconnect the power cord from the customer supply while performing tasks that do not need electricity. Electricity can cause death or injury. Moving parts can cause injury.**

Perform the following:

1. Ensure that the paper tray settings match the paper or media size in the trays.
2. Perform the Shading Test procedure, GP 15. If the shading test fails, install new components as necessary:
  - CCD module, PL 14.10 Item 8.
  - CCD module cable, PL 14.10 Item 23.
  - Scanner assembly, PL 14.10 Item 26.
3. Refer to Wiring Diagram 2. Perform the following:
  - Check the spring contacts between the HVPS PL 1.10 Item 3 and the print cartridge PL 9.10 Item 1. The spring contacts supply the voltages to the print cartridge. If necessary, clean the spring contacts.
  - If necessary, install a new HVPS, PL 1.10 Item 3.
4. Perform OF7 Main PWB Check RAP.

## IQ9 Background RAP

Use this RAP when the printed sheets have a dark or spotted background, as shown in Figure 1.



AP-1-1517-A

Figure 1 Background

### Procedure

#### WARNING

**Switch off the electricity to the machine. Disconnect the power cord from the customer supply while performing tasks that do not need electricity. Electricity can cause death or injury. Moving parts can cause injury.**

Perform the following:

1. Ensure that the paper tray settings match the paper or media size in the trays. Also, ensure the media is within specification. Refer to GP 9 Paper and Media Specifications.
2. Ensure the machine is being operated in the correct environmental conditions. Refer to GP 7 Machine Specifications.
3. Clean the xerographic drum, make 10 blank copies. If necessary, install a new print cartridge, PL 9.10 Item 1.
4. Check the transfer roll, PL 9.10 Item 2. Make sure the transfer roll is clean and moves up and down smoothly. If necessary, install a new transfer roll, PL 9.10 Item 2.
5. Refer to Wiring Diagram 2. Perform the following:
  - Check the spring contacts between the HVPS, PL 1.10 Item 3, and the print cartridge PL 9.10 Item 1. The spring contacts supply the voltages to the print cartridge. If necessary, clean the spring contacts.
  - Install a new HVPS, PL 1.10 Item 3.

## IQ10 Ghost Images RAP

Use this RAP when the printed sheets have ghost images, as shown in Figure 1.



AP-1-1518-A

Figure 1 Ghost images

### Procedure

#### WARNING

Switch off the electricity to the machine. Disconnect the power cord from the customer supply while performing tasks that do not need electricity. Electricity can cause death or injury. Moving parts can cause injury.

#### WARNING

Do not touch the fuser while it is hot.

Perform the following:

1. Measure the distance between the image and the ghosted image. Refer to Table 1 to determine the possible cause of the defect.

Table 1 Defect distance

Defect distance	Roll	Component	Parts List Ref.
95mm (3.7 inches)	Xerographic drum	Print cartridge	PL 9.10 Item 1
38mm (1.5 inches)	Charge roll	Print cartridge	PL 9.10 Item 1
45mm (1.8 inches)	Supply roll	Print cartridge	PL 9.10 Item 1
47mm (1.9 inches)	Transfer roll	Transfer roll	PL 9.10 Item 2
89mm (3.5 inches)	Heat roll	Fuser assembly	PL 10.15 Item 1
51mm (2 inches)	Pressure roll 1	Fuser assembly	PL 10.15 Item 2
64mm (2.5 inches)	Pressure roll 2	Fuser assembly	PL 10.15 Item 3

2. If the distance between the image and the defect matches the print cartridge, perform the following:

- Ensure that the paper tray settings match the paper or media size in the trays. Ensure the media is within specification. Refer to GP 9 Paper and Media Specifications.
  - Refer to Wiring Diagram 2. Check the spring contacts between the HVPS, PL 1.10 Item 3, and the print cartridge, PL 9.10 Item 1. The spring contacts supply the voltages to the print cartridge. If necessary, clean the spring contacts.
  - If necessary, install a new print cartridge, PL 9.10 Item 1.
3. If the distance between the image and the defect matches the transfer roll perform the following:
    - Check the transfer roll, PL 9.10 Item 2, clean as required. If the lifetime of the transfer roll is greater than 70K sheets, install a new transfer roll, PL 9.10 Item 2.
  4. If the distance between the image and the defect matches the heat roll or pressure rolls, perform the following:
    - Enter dC330 code 10-200 and 10-210. Ensure that the fuser is operating within the correct temperature range. Refer to GP 7 Machine Specifications.
    - Switch off the machine. Remove the fuser assembly. Check that the thermistor, PL 10.12 Item 16 is clean and in good contact with the fuser. Check the wiring to the thermistor. Install new components as necessary, PL 10.10 to PL 10.15.

## IQ11 Stains on Back of Paper RAP

Use this RAP when the printed sheets have stains on the non-image side of the paper.

### Procedure

#### WARNING

**Switch off the electricity to the machine. Disconnect the power cord from the customer supply while performing tasks that do not need electricity. Electricity can cause death or injury. Moving parts can cause injury.**

Perform the following:

1. Check the transfer roll, PL 9.10 Item 2. Clean as required or install a new transfer roll, PL 9.10 Item 2.
2. Check the paper path for dirt and contamination. Clean as required.
3. Check the fuser assembly for contamination. Install new components as necessary, PL 10.10 to PL 10.15.

## IQ12 Poor Fusing RAP

Use this RAP when the image is improperly fused.

### Procedure

#### WARNING

**Switch off the electricity to the machine. Disconnect the power cord from the customer supply while performing tasks that do not need electricity. Electricity can cause death or injury. Moving parts can cause injury.**

#### WARNING

**Do not touch the fuser while it is hot.**

Perform the following:

1. Ensure that the paper tray settings match the paper or media size in the trays. Also ensure the media is within specification. Refer to GP 9 Paper and Media Specifications.
2. Examine the fuser assembly PL 10.10. Ensure the thermistor PL 10.12 Item 16 is clean and in good contact with the fuser.
3. Ensure the machine is being operated in the correct environmental conditions. Refer to GP 7 Machine Specifications.
4. If the machine has been standing in a low temperature environment for a long time, try to bring the environment up to a warmer temperature before re-trying the machine.
5. Refer to Wiring Diagram 1. Perform the following:
  - Check the wiring between CON2 on the SMPS and the fuser assembly.
  - If necessary, install a new SMPS, PL 1.12 Item 3.
6. If necessary, go to the 10-100, 200 Open Fuser Error/Low Heat Error RAP.

## IQ13 Partial Blank Image (Not Periodic) RAP

Use this RAP when the printed sheets have blank areas, that do not form a regular pattern.

### Procedure

#### WARNING

Switch off the electricity to the machine. Disconnect the power cord from the customer supply while performing tasks that do not need electricity. Electricity can cause death or injury. Moving parts can cause injury.

Perform the following:

1. Install a new print cartridge, PL 9.10 Item 1.

## IQ14 Partial Blank Image (Periodic) RAP

Use this RAP when the printed sheets have blank areas that form a regular, or repeated, defect.

### Procedure

#### WARNING

Switch off the electricity to the machine. Disconnect the power cord from the customer supply while performing tasks that do not need electricity. Electricity can cause death or injury. Moving parts can cause injury.

Perform the following:

1. Measure the distance between the image and the defect. Refer to Table 1 to determine the possible cause of the defect.

Table 1 Defect distance

Defect distance	Roll	Component	Parts List Ref.
95mm (3.7 inches)	Xerographic drum	Print cartridge	PL 9.10 Item 1
38mm (1.5 inches)	Charge roll	Print cartridge	PL 9.10 Item 1
45mm (1.8 inches)	Supply roll	Print cartridge	PL 9.10 Item 1
47mm (1.9 inches)	Transfer roll	Transfer roll	PL 9.10 Item 2
89mm (3.5 inches)	Heat roll	Fuser assembly	PL 10.15 Item 1
51mm (2 inches)	Pressure roll 1	Fuser assembly	PL 10.15 Item 2
64mm (2.5 inches)	Pressure roll 2	Fuser assembly	PL 10.15 Item 3

2. Install new components as necessary.

## IQ15 Different Image Density (Left and Right) RAP

Use this RAP when the printed sheets have different areas of image density across the process direction. An example is shown in Figure 1.



AP-1-1519-A

Figure 1 Image density

## IQ16 Horizontal Bands RAP

Use this RAP when the image has bands appearing across the process direction. An example is shown in Figure 1.

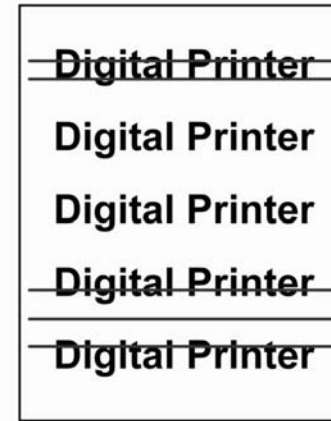

AP-1-1520-A

Figure 1 Horizontal bands

### Procedure

#### WARNING

Switch off the electricity to the machine. Disconnect the power cord from the customer supply while performing tasks that do not need electricity. Electricity can cause death or injury. Moving parts can cause injury.

Perform the following:

1. The transfer roll pressure may be unbalanced. Check the spring pressure at each end, PL 9.10. Install new components as necessary, PL 9.10.
2. Shake the print cartridge to evenly distribute the toner. If necessary, install a new print cartridge, PL 9.10 Item 1.
3. If necessary, install a new print cartridge, PL 9.10 Item 1.
4. Perform the Shading Test procedure, GP 15. If the shading test fails:
  - a. Install new components as necessary:
    - CCD module, PL 14.10 Item 8.
    - CCD module cable, PL 14.10 Item 23.
    - Scanner assembly, PL 14.10 Item 26.
  - b. Perform OF7 Main PWB Check RAP.

### Procedure

#### WARNING

Switch off the electricity to the machine. Disconnect the power cord from the customer supply while performing tasks that do not need electricity. Electricity can cause death or injury. Moving parts can cause injury.

Perform the following:

1. Refer to Wiring Diagram 2. Check the spring contacts between the HVPS PL 1.10 Item 3 and the print cartridge PL 9.10 Item 1. The spring contacts supply the voltages to the print cartridge. If necessary, clean the spring contacts.
2. If necessary, install a new print cartridge, PL 9.10 Item 1.
3. Measure the distance between the image and the defect. Refer to Table 1 to determine the possible cause of the defect.

Table 1 Defect distance

Defect distance	Roll	Component	Parts List Ref.
95mm (3.7 inches)	Xerographic drum	Print cartridge	PL 9.10 Item 1
38mm (1.5 inches)	Charge roll	Print cartridge	PL 9.10 Item 1
45mm (1.8 inches)	Supply roll	Print cartridge	PL 9.10 Item 1
47mm (1.9 inches)	Transfer roll	Transfer roll	PL 9.10 Item 2
89mm (3.5 inches)	Heat roll	Fuser assembly	PL 10.15 Item 1
51mm (2 inches)	Pressure roll 1	Fuser assembly	PL 10.15 Item 2
64mm (2.5 inches)	Pressure roll 2	Fuser assembly	PL 10.15 Item 3

4. Install new components as necessary.
5. Check the condition of the fuser assembly. Install new components as necessary, PL 10.10 to PL 10.15.
6. Perform OF7 Main PWB Check RAP.

## IQ17 Periodic Printing Defects Check RAP

Use this RAP when the printed image shows regular defects in black or white, across the process direction.

### Procedure

#### WARNING

**Switch off the electricity to the machine. Disconnect the power cord from the customer supply while performing tasks that do not need electricity. Electricity can cause death or injury. Moving parts can cause injury.**

1. Clean the xerographic drum, make 10 blank copies. If necessary, install a new print cartridge, PL 9.10 Item 1.
2. Measure the distance between the repeated black or white abnormality. Refer to Table 1 identify the possible cause.

**Table 1 Defect distance**

Defect distance	Kind of abnormal image	Roll	Component	Parts List Ref.
95mm (3.7 inches)	White spot. Black spot	Xerographic drum	Print cartridge	PL 9.10 Item 1
38mm (1.5 inches)	White spot. Black spot	Charge roll	Print cartridge	PL 9.10 Item 1
45mm (1.8 inches)	Horizontal dark band	Supply roll	Print cartridge	PL 9.10 Item 1
47mm (1.9 inches)	Black spot, White spot	Transfer roll	Transfer roll	PL 9.10 Item 2
89mm (3.5 inches)	Black spot, White spot	Heat roll	Fuser assembly	PL 10.15 Item 1
51mm (2 inches)	Back side contamination	Pressure roll 1	Fuser assembly	PL 10.15 Item 2
64mm (2,5 inches)	Back side contamination	Pressure roll 2	Fuser assembly	PL 10.15 Item 3

3. Install new components as necessary.
4. If the defect appears to be fuser related, ensure that the paper tray settings match the paper or media size in the trays. Also, ensure the media is within specification. Refer to GP 9 Paper and Media Specifications.

## IQ18 DADF Lead Edge Offset RAP

Use this RAP when copies from the DADF have lead edge offset.

### Procedure

#### WARNING

**Switch off the electricity to the machine. Disconnect the power cord from the customer supply while performing tasks that do not need electricity. Electricity can cause death or injury. Moving parts can cause injury.**

Refer to Wiring Diagram 10. Perform the following:

1. Open the DADF door assembly, PL 5.10 Item 3.
2. Check the document path for damage or obstructions.
3. Check that the following components are clean and rotate freely.
  - Registration roll, PL 5.35 Item 8.
  - Registration roll idlers, PL 5.15 Item 8.
4. Check that the registration sensor actuator, PL 5.35 Item 7 moves freely and is not damaged.
5. Enter dC330 code 05-130. Check the registration sensor (Q05-130), PL 5.35 Item 7. If necessary, install a new registration sensor.
6. If the fault is still present, install a new transport assembly, REP 5.4.

## IQ19 Poor Registration RAP

Use this RAP when the copies are poorly registered.

### Procedure

#### WARNING

**Switch off the electricity to the machine. Disconnect the power cord from the customer supply while performing tasks that do not need electricity. Electricity can cause death or injury. Moving parts can cause injury.**

Perform the following:

1. Check that the paper guides in all trays are correctly positioned. Check that the DADF document guides are correctly positioned.
2. Make a duplex copy from each paper tray.
3. Check the copies. If all the copies have poor side registration, perform the following:
  - a. Remove the DADF. Check the DADF counterbalances for damage. Install new components as necessary, PL 5.10 Item 7 and PL 5.10 Item 8.
  - b. Adjust the DADF side edge registration. Go to ADJ 5.1 DADF Side Edge Registration Adjustment.
4. If the copy from a tray is poor, perform the relevant procedure:
  - ADJ 8.1 Lead Edge Registration Adjustment.
  - ADJ 8.2 Side Edge Registration Adjustment.

# IQS 1 Solid Area Density

## Documents

Test pattern: solid area density scales, 82E8230 (SIR 542.00) or 82P448 (SIR 494.00).

## Specification

Make a copy of the test pattern. Compare the copy with the solid area density scale. The density of the 1.0 areas on the copy of the test pattern, must be as dark or darker than the 0.8 reference on the solid area density scale. Refer to Figure 1.

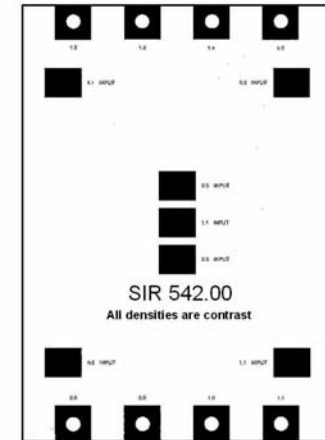
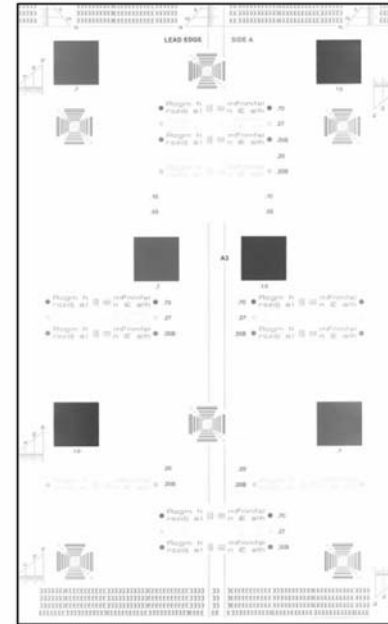

AP-1-1545-A

Figure 1 Solid area density

## Corrective Action

Go to the IQ1 Image Quality Entry RAP.

## IQS 2 Skew

### Documents

Test pattern: 82E2020 (8.5 x 11) or 82E2010 (A4).

### Specification

Refer to Table 1.

**Table 1 Skew specifications**

Skew	Specification
Print Skew	Max: +/-2.5mm (7/64 inch) per 250mm (10 inches) (+/-1%)

## IQS 3 Registration

### Documents

Test pattern: 82E2020 (8.5 x 11) or 82E2010 (A4).

### Specifications

Refer to Table 1.

**Table 1 Registration measurement**

Registration	Specification
Lead edge	4mm (5/32 inches) +/- 3mm (1/8 inches)
Top edge	4mm (5/32 inches) +/- 3mm (1/8 inches)

### Corrective Action

Go to the IQ19 Poor Registration RAP.

# 4 Repairs and Adjustments

## REPs 1 - Standby Power

REP 1.1 SMPS.....	4-3
REP 1.2 HVPS.....	4-4

## REPs 2 - User Interface

REP 2.1 User Interface Assembly.....	4-5
REP 2.2 UI PWB and Touch Screen.....	4-6

## REPs 3 - Machine Run Control

REP 3.1 Main PWB.....	4-9
REP 3.2 USB PWB and Harness.....	4-10

## REPs 4 - Main Drives

REP 4.1 Main BLDC Motor.....	4-11
------------------------------	------

## REPs 5 - DADF

REP 5.1 DADF Door Open Sensor.....	4-13
REP 5.2 DADF Lift Solenoid.....	4-13
REP 5.3 DADF Registration and Scan Sensors.....	4-14
REP 5.4 DADF Transport Assembly and DADF Feed Assembly.....	4-15
REP 5.5 DADF Drive Assembly.....	4-17
REP 5.6 DADF Paper Length Sensor.....	4-18
REP 5.7 Pickup Assembly.....	4-18

## REPs 6 - LSU

REP 6.1 LSU.....	4-21
REP 6.2 LSU Interlock Switch.....	4-21

## REPs 7 - Paper Supply

REP 7.1 Bypass Feed Assembly.....	4-23
REP 7.2 Registration Solenoid and Tray 1 Pickup Solenoid.....	4-23
REP 7.3 Bypass Pickup Roll.....	4-24
REP 7.4 Tray 2 Feed Motor and Pickup Solenoid.....	4-24
REP 7.5 Bypass Paper Empty Sensor.....	4-25

## Chain 8 - Paper Transport

REP 8.1 Registration Roll Clutch.....	4-27
---------------------------------------	------

## REPs 9 - Xerographics

REP 9.1 CRUM PWB.....	4-29
-----------------------	------

## REPs 10 - Fusing and Copy/Print Transport

REP 10.1 Duplex Motor.....	4-31
REP 10.2 Exit Motor.....	4-31
REP 10.3 Front Duplex Guide Assembly.....	4-32
REP 10.4 Exit Roll and Exit Idler Assemblies.....	4-33
REP 10.5 Fuser Terminal.....	4-34
REP 10.6 Heat Lamp.....	4-34

## REPs 14 - Scanner

REP 14.1 Scanner Assembly.....	4-37
REP 14.2 Scanner Components.....	4-38

## REPs - 28 External Covers

REP 28.1 External Covers.....	4-41
REP 28.2 Outbin Assembly.....	4-42
REP 28.3 Front Mid Cover.....	4-43

## ADJs 1 - Standby Power

ADJ 1.1 Machine Settings.....	4-45
-------------------------------	------

## ADJs 5 - Document Transport

ADJ 5.1 DADF Side Edge Registration Adjustment.....	4-47
---	------

## ADJs 8 - Paper Transport

ADJ 8.1 Lead Edge Registration Adjustment.....	4-49
ADJ 8.2 Side Edge Registration Adjustment.....	4-50

## REP 1.1 SMPS

### Parts List on PL 1.12

#### Removal

#### WARNING

Switch off the electricity to the machine. Disconnect the power cord from the customer supply while performing tasks that do not need electricity. Electricity can cause death or injury. Moving parts can cause injury.

#### WARNING

Take care during this procedure. Sharp edges may be present that can cause injury.

#### CAUTION

Before performing this procedure, refer to General Disassembly Precautions, GP 10.



#### CAUTION

Ensure that E.S.D. procedures are observed during the removal and installation of the main PWB. Make a visual check to ensure that the pins are fully inserted, without being damaged.

1. Remove the right side cover, REP 28.1.
2. Remove the duplex drive assembly, refer to REP 10.1.
3. Disconnect the inline connector in the harness from the SMPS fan.
4. Remove the SMPS cover, PL 1.12 Item 2.
5. Disconnect the following connectors from the SMPS:
  - CON1
  - CON2
  - CON3

6. Remove the SMPS, Figure 1.

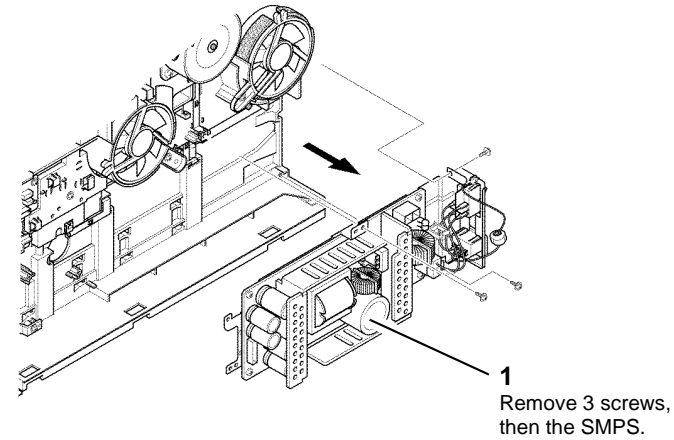

Figure 1 SMPS removal

AP-1-1506-A

#### Replacement

Replacement is the reverse of the removal procedure.

## REP 1.2 HVPS

### Parts List on PL 1.10

#### Removal

#### WARNING

Switch off the electricity to the machine. Disconnect the power cord from the customer supply while performing tasks that do not need electricity. Electricity can cause death or injury. Moving parts can cause injury.

#### WARNING

Take care during this procedure. Sharp edges may be present that can cause injury.

#### CAUTION

Before performing this procedure, refer to General Disassembly Precautions, GP 10.



#### CAUTION

Ensure that E.S.D. procedures are observed during the removal and installation of the main PWB. Make a visual check to ensure that the pins are fully inserted, without being damaged.

1. Remove the DADF, PL 5.10 Item 1.
2. Remove the print cartridge, PL 9.10 Item 1.
3. Remove the right side cover, REP 28.1.
4. Remove tray 1.
5. Remove the duplex assembly, PL 10.23 Item 18.
6. Remove the duplex drive assembly, refer to REP 10.1.
7. Remove the front duplex guide assembly, REP 10.3.
8. Carefully rest the machine on the rear cover.
9. Remove 8 screws to release the HVPS assembly, PL 1.10 Item 3.

#### CAUTION

Take care not to allow the 2 harnesses to slip through the frame when they are disconnected from the HVPS assembly.

10. Disconnect 2 connectors from the HVPS.
11. Remove the HVPS assembly, PL 1.10 Item 6.
12. Remove 3 screws to remove the HVPS from the shield.

#### Replacement

1. Attach the HVPS to the shield using 3 screws.
2. Carefully rest the machine on the rear cover.
3. Insert the HVPS assembly into the machine, then connect the connectors.
4. Attach the HVPS assembly to the machine by installing the screws in number order from 1 to 8 as indicated on the shield.

5. Replacement is the reverse of the removal procedure.

## REP 2.1 User Interface Assembly

### Parts List on PL 2.10

#### Removal

#### WARNING

Switch off the electricity to the machine. Disconnect the power cord from the customer supply while performing tasks that do not need electricity. Electricity can cause death or injury. Moving parts can cause injury.

#### CAUTION

Before performing this procedure, refer to General Disassembly Precautions, GP 10.

1. Remove the UI inlay, Figure 1.

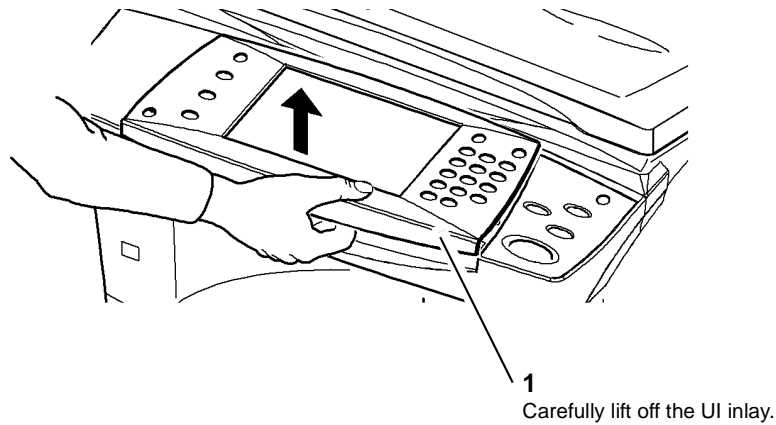

AP-1-1524-A

Figure 1 UI inlay removal

#### CAUTION

Take care to identify the connections to the UI PWB. The 3 pin connections are interchangeable.

- CN2, 3 wires: 1 black, 1 white, 1 red.
  - CN11, 4 wires: 1 black, 3 gray.
2. Remove the UI panel assembly, Figure 2.

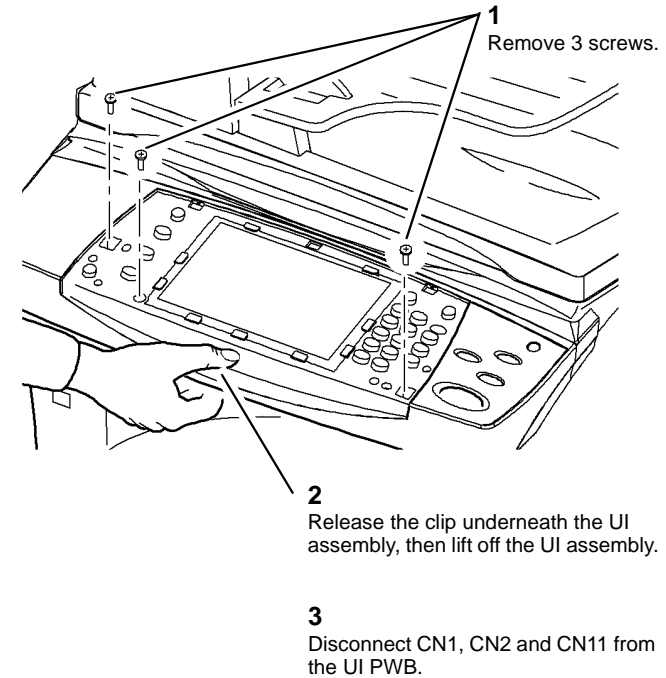

AP-1-1525-A

Figure 2 UI assembly removal

#### Replacement

1. Replacement is the reverse of the removal procedure.

## REP 2.2 UI PWB and Touch Screen

### Parts List on PL 2.10

#### Removal

#### WARNING

Switch off the electricity to the machine. Disconnect the power cord from the customer supply while performing tasks that do not need electricity. Electricity can cause death or injury. Moving parts can cause injury.

#### CAUTION

Before performing this procedure, refer to *General Disassembly Precautions, GP 10*.

1. Remove the user interface assembly, REP 2.1.

#### CAUTION

Take care not to damage the ribbon cables when removing the UI PWB.

2. Remove the UI PWB, PL 2.10 Item 24, from the user interface assembly, Figure 1.

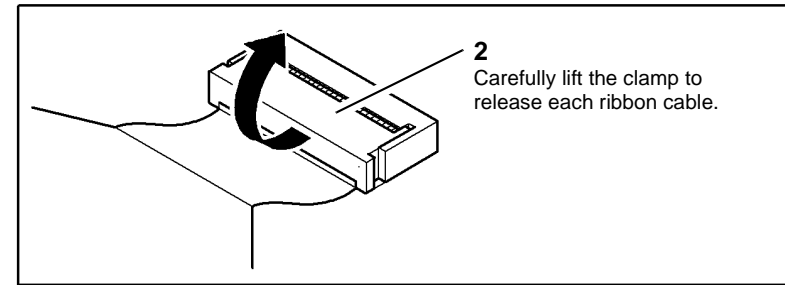

- 3 Remove 4 screws marked A, then the UI PWB.
- 1 Disconnect CN3 and CN4 from the UI PWB.

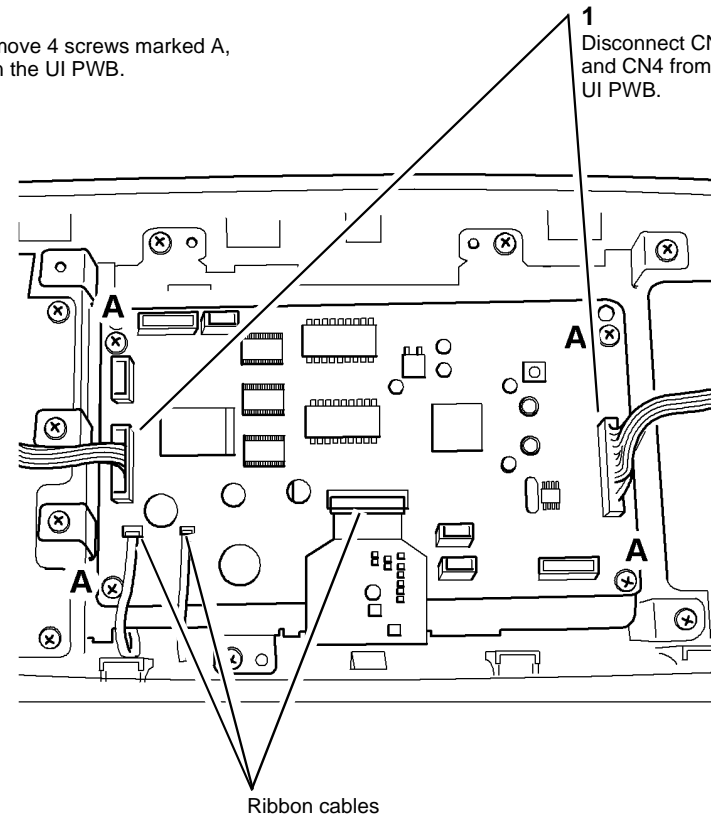

AP-1-1536-A

Figure 1 UI PWB removal

3. If necessary, remove the touch screen, PL 2.10 Item 25, and the touch screen housing, PL 2.10 Item 26, from the user interface assembly.

### **Replacement**

1. Replacement is the reverse of the removal procedure.

## REP 3.1 Main PWB

### Parts List on PL 3.10

#### Removal

#### WARNING

Switch off the electricity to the machine. Disconnect the power cord from the customer supply while performing tasks that do not need electricity. Electricity can cause death or injury. Moving parts can cause injury.

#### WARNING

Take care during this procedure. Sharp edges may be present that can cause injury.

#### CAUTION

Before performing this procedure, refer to General Disassembly Precautions, GP 10.



#### CAUTION

Ensure that E.S.D. procedures are observed during the removal and installation of the main PWB. Make a visual check to ensure that the pins are fully inserted, without being damaged.

1. If a new main PWB is to be installed, go to GP 3 Machine Status. If possible, print the following reports:
  - System Configuration.
  - Local Address Book Members.
  - Group Address Book Members.
2. Remove the left cover, REP 28.1.

#### CAUTION

Take care to identify the connections to the Main PWB. The 4 pin connectors are interchangeable.

- CN4, 4 wires: 3 grey, 1 black.
  - CN5, 3 wires: 2 grey, 1 black.
  - CN17, 4 wires: 3 grey, 1 black.
  - CN18, not used.
  - CN36, 4 wires: 2 grey 2 black.
3. Unplug all the connectors from the main PWB, PL 3.10 Item 6.
  4. Remove the MSOK, PL 3.10 Item 14.
  5. Remove the memory DIMM, PL 3.10 Item 10.
  6. Remove the SIM card holder, PL 3.10 Item 8.
  7. If installed, remove the foreign device interface PWB, PL 3.10 Item 7.
  8. Remove 5 screws, then the main PWB, PL 3.10 Item 6.

#### Replacement

1. Replacement is the reverse of the removal procedure.
2. If a new main PWB has been installed, perform the following:
  - a. Install the MSOK onto the new main PWB, PL 3.10 Item 14.
  - b. Install the memory DIMM onto the main PWB, PL 3.10 Item 10.
  - c. Use the information on the printed lists to re-enter the customer's settings. Refer to GP 4 System Administration Tools.

## REP 3.2 USB PWB and Harness

### Parts List on PL 3.10

#### Removal

#### WARNING

Switch off the electricity to the machine. Disconnect the power cord from the customer supply while performing tasks that do not need electricity. Electricity can cause death or injury. Moving parts can cause injury.

#### CAUTION

*Before performing this procedure, refer to General Disassembly Precautions, GP 10.*

1. Remove the DADF, PL 5.10 Item 1.
2. Remove the UI assembly, REP 2.1.
3. Remove the scanner assembly, REP 14.1.
4. Remove the USB harness, PL 3.10 Item 13.
5. Remove the USB host PWB, PL 3.10 Item 11.

#### Replacement

1. Replacement is the reverse of the removal procedure.

## REP 4.1 Main BLDC Motor

### Parts List on PL 4.10

#### Removal

#### WARNING

Switch off the electricity to the machine. Disconnect the power cord from the customer supply while performing tasks that do not need electricity. Electricity can cause death or injury. Moving parts can cause injury.

#### WARNING

Take care during this procedure. Sharp edges may be present that can cause injury.

#### CAUTION

Before performing this procedure, refer to *General Disassembly Precautions, GP 10*.

1. Remove the left cover, REP 28.1.

#### CAUTION

Take care to identify the connections to the Main PWB. The 4 pin connections are interchangeable.

- CN4, 4 wires: 3 grey, 1 black.
- CN5, 3 wires: 2 grey, 1 black.
- CN17, 4 wires: 3 grey, 1 black.
- CN18, not used.
- CN38, 4 wires: 2 grey 2 black.

2. Reposition the main PWB assembly to allow access the main drive assembly, Figure 1.

**NOTE:** Disconnect harnesses as required to allow access to the main drive assembly.

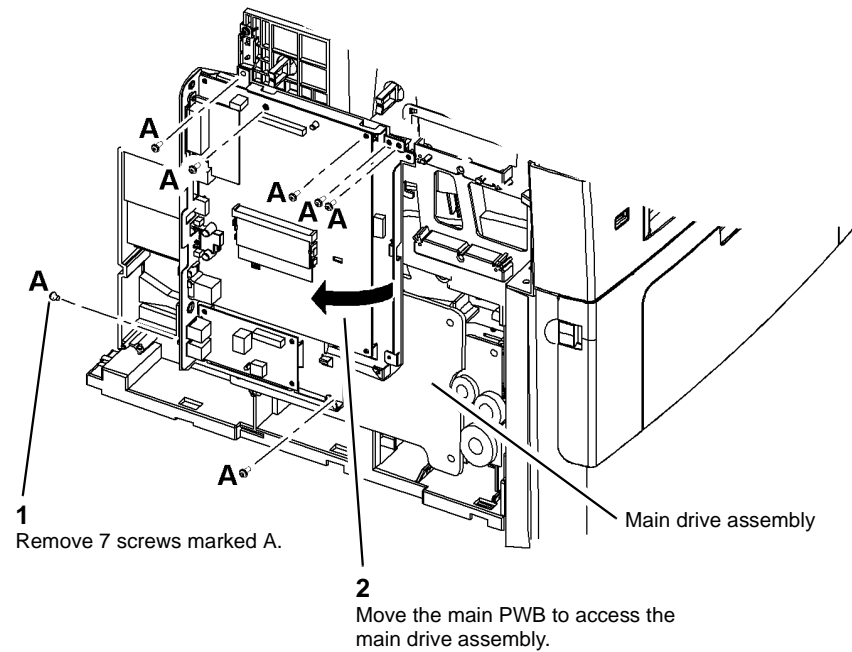

AP-1-1529-A

**Figure 1 Main drive assembly access**

3. Remove 5 screws numbered 1 to 5, then remove the main drive assembly, PL 3.10 Item 1.
4. Remove 4 screws, then remove the main BLDC motor from the assembly, PL 4.10 Item 1.

#### Replacement

1. Install the main BLDC motor, PL 4.10 Item 1 to the main drive assembly using 4 screws.
2. Install 5 screws numbered 1 to 5 to install the main drive assembly, refer to Figure 1.
3. Reinstall the main PWB assembly.
4. Replacement is the reverse of the removal procedure.

## REP 5.1 DADF Door Open Sensor

Parts List on PL 5.40

### Removal

#### WARNING

Switch off the electricity to the machine. Disconnect the power cord from the customer supply while performing tasks that do not need electricity. Electricity can cause death or injury. Moving parts can cause injury.

#### WARNING

Take care during this procedure. Sharp edges may be present that can cause injury.

#### CAUTION

Before performing this procedure, refer to *General Disassembly Precautions, GP 10*.

1. Remove the DADF, PL 5.10 Item 1.
2. Remove the DADF rear cover, PL 5.10 Item 9.
3. Remove the DADF door open sensor, PL 5.40 Item 13.

### Replacement

1. Replacement is the reverse of the removal procedure.

## REP 5.2 DADF Lift Solenoid

Parts List on PL 5.15

### Removal

#### WARNING

Switch off the electricity to the machine. Disconnect the power cord from the customer supply while performing tasks that do not need electricity. Electricity can cause death or injury. Moving parts can cause injury.

#### CAUTION

Before performing this procedure, refer to *General Disassembly Precautions, GP 10*.

1. Remove the DADF, PL 5.10 Item 1.
2. Remove the DADF rear cover, PL 5.10 Item 9.
3. Remove the DADF front cover, PL 5.10 Item 10.
4. Remove the input tray assembly, PL 5.15 Item 2.
5. Remove the DADF lift solenoid, Figure 1.

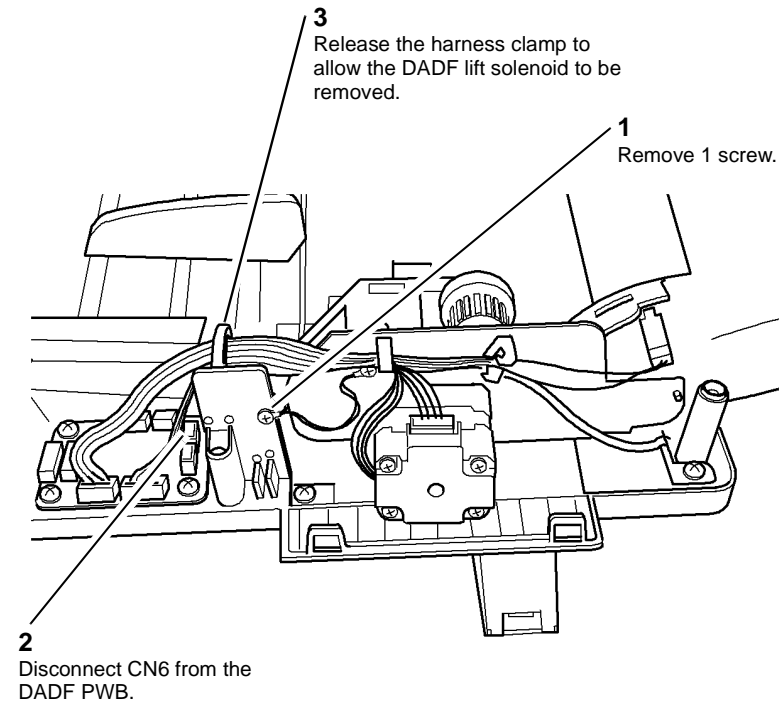

AP-1-1537-A

Figure 1 Lift solenoid removal

## Replacement

### WARNING

Ensure all ground leads are connected.

1. Replacement is the reverse of the removal procedure.

## REP 5.3 DADF Registration and Scan Sensors

Parts List on PL 5.35

### Removal

### WARNING

Switch off the electricity to the machine. Disconnect the power cord from the customer supply while performing tasks that do not need electricity. Electricity can cause death or injury. Moving parts can cause injury.

### CAUTION

Before performing this procedure, refer to General Disassembly Precautions, GP 10.

1. Remove the DADF, PL 5.10 Item 1.
2. Remove the DADF rear cover, PL 5.10 Item 9.
3. Remove the DADF door assembly, PL 5.10 Item 3.
4. Release the DADF feed assembly, PL 5.10 Item 4.

**NOTE:** It is not necessary to disconnect the harness from the DADF feed assembly.

5. Remove the DADF transport assembly upper cover, PL 5.35 Item 13.
6. Remove the DADF registration sensor or scan sensor as necessary, Figure 1.

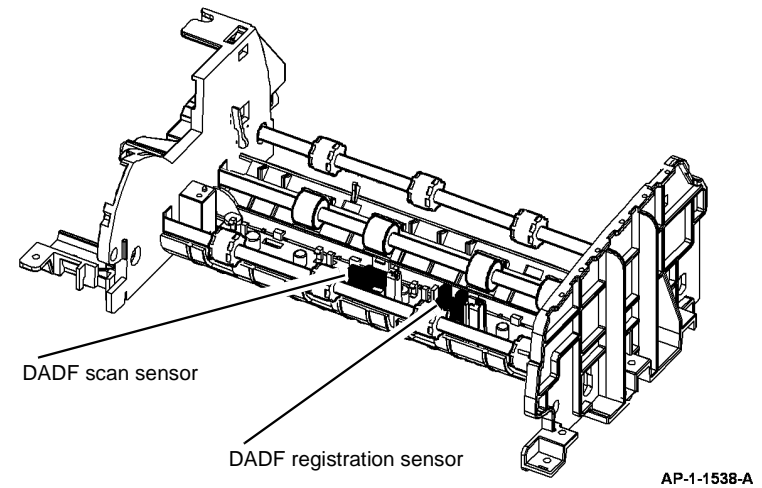

Figure 1 Sensor location

### Replacement

1. Replacement is the reverse of the removal procedure.

## REP 5.4 DADF Transport Assembly and DADF Feed Assembly

Parts List on PL 5.30 and PL 5.35

### Removal

#### WARNING

Switch off the electricity to the machine. Disconnect the power cord from the customer supply while performing tasks that do not need electricity. Electricity can cause death or injury. Moving parts can cause injury.

#### WARNING

Take care during this procedure. Sharp edges may be present that can cause injury.

#### CAUTION

Before performing this procedure, refer to General Disassembly Precautions, GP 10.

1. Remove the DADF, PL 5.10 Item 1.
2. Remove the DADF rear cover, PL 5.10 Item 9.
3. Remove the DADF door assembly, PL 5.10 Item 3.
4. Remove the DADF lift solenoid, REP 5.2.
5. Disconnect the following connectors from the DADF PWB:
  - CN1
  - CN5
  - CN7
  - CN8
  - CN9
6. Remove the DADF transport and feed assemblies, Figure 1.

*NOTE: The DADF transport and feed assemblies are removed as a unit.*

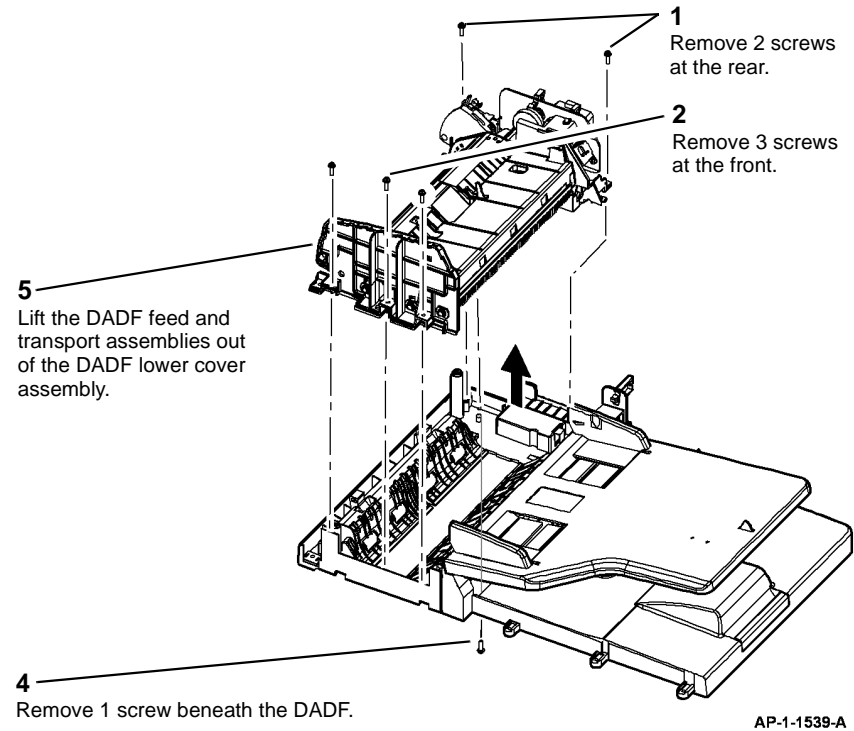

**Figure 1 Transport and feed assemblies removal**

7. If required, separate the DADF feed assembly from the DADF transport assembly, Figure 2.

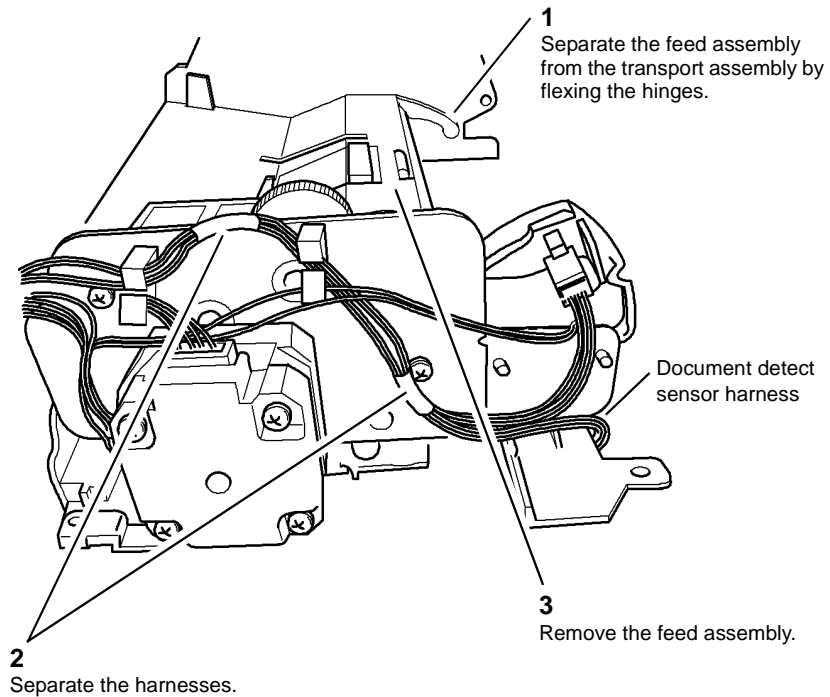

AP-1-1540-A

Figure 2 Feed assembly removal

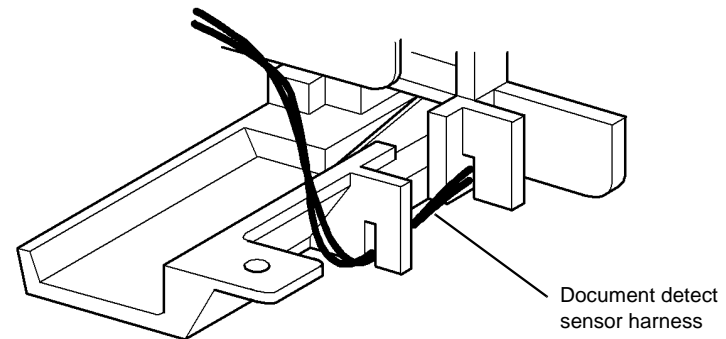

AP-1-1550-A

Figure 3 Harness routing

## Replacement

### WARNING

Ensure all ground leads are connected.

1. Replacement is the reverse of the removal procedure. Make sure the document detect sensor harness is routed correctly before reinstalling the feed assembly, refer to Figure 2 and Figure 3.

## REP 5.5 DADF Drive Assembly

### Parts List on PL 5.40

#### Removal

#### WARNING

Switch off the electricity to the machine. Disconnect the power cord from the customer supply while performing tasks that do not need electricity. Electricity can cause death or injury. Moving parts can cause injury.

#### WARNING

Take care during this procedure. Sharp edges may be present that can cause injury.

#### CAUTION

Before performing this procedure, refer to *General Disassembly Precautions, GP 10*.

1. Remove the DADF, PL 5.10 Item 1.
2. Remove the DADF rear cover, PL 5.10 Item 9.
3. Remove the DADF door assembly, PL 5.10 Item 3.
4. Remove the DADF lift solenoid, REP 5.2.
5. Remove the DADF transport and feed assemblies, REP 5.4.
6. Remove the DADF drive assembly, Figure 1.

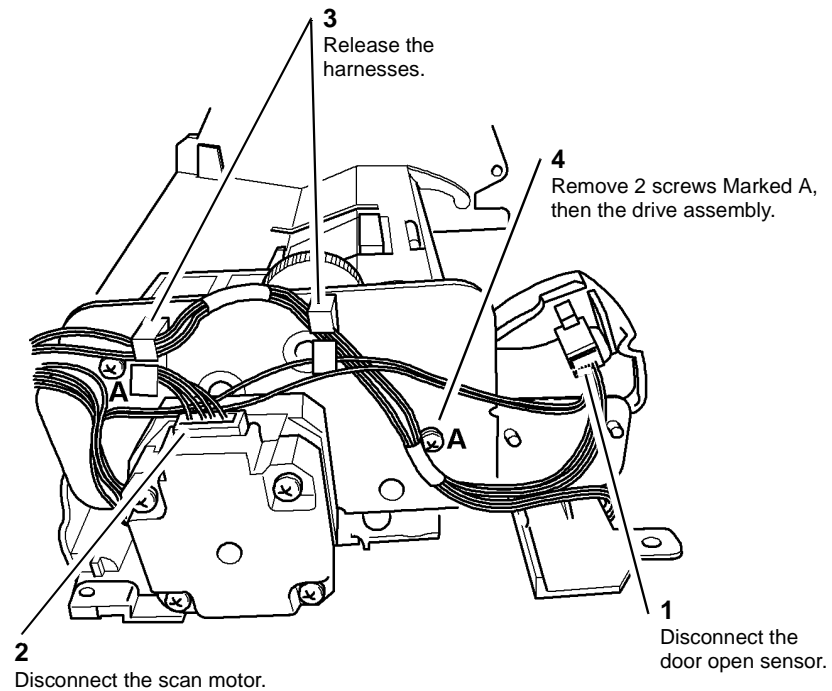

AP-1-1541-A

Figure 1 Drive assembly removal

7. Remove the registration solenoid, pickup solenoid or scan motor as required, Figure 2.

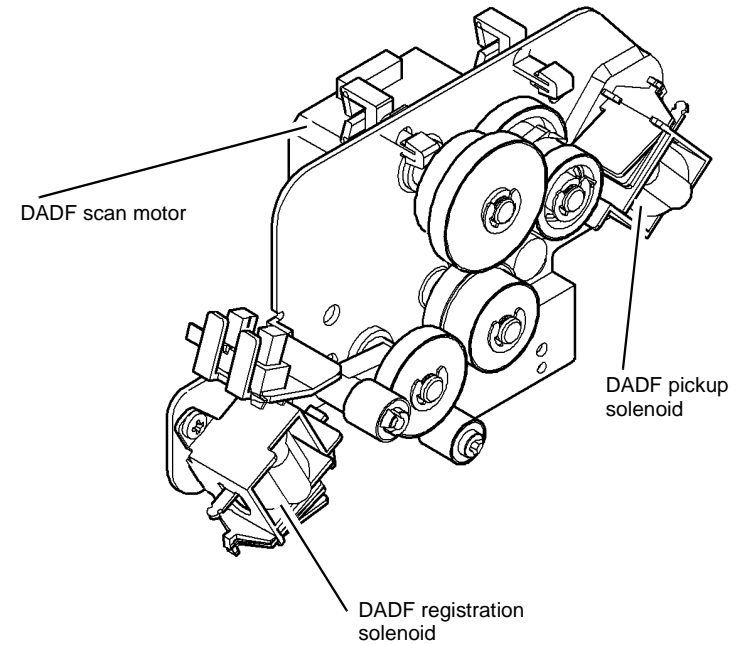

AP-1-1542-A

Figure 2 Solenoid and motor removal

#### Replacement

#### WARNING

Ensure all ground leads are connected.

1. Replacement is the reverse of the removal procedure.

## REP 5.6 DADF Paper Length Sensor

Parts List on PL 5.20

### Removal

#### WARNING

Switch off the electricity to the machine. Disconnect the power cord from the customer supply while performing tasks that do not need electricity. Electricity can cause death or injury. Moving parts can cause injury.

#### CAUTION

Before performing this procedure, refer to *General Disassembly Precautions, GP 10*.

1. Remove the DADF, PL 5.10 Item 1.
2. Remove the DADF rear cover, PL 5.10 Item 9.
3. Remove the DADF front cover, PL 5.10 Item 10.
4. Remove 3 screws to remove the input tray, PL 5.20 Item 1.
5. Remove the sensor assembly cover, PL 5.20 Item 12.
6. Remove the DADF paper length sensor, PL 5.20 Item 11.

### Replacement

1. Replacement is the reverse of the removal procedure.

## REP 5.7 Pickup Assembly

Parts List on PL 5.25

### Removal

#### WARNING

Switch off the electricity to the machine. Disconnect the power cord from the customer supply while performing tasks that do not need electricity. Electricity can cause death or injury. Moving parts can cause injury.

#### CAUTION

Before performing this procedure, refer to *General Disassembly Precautions, GP 10*.

1. Remove the DADF, PL 5.10 Item 1.
2. Remove the DADF door assembly, PL 5.10 Item 3.
3. Release the pickup spring PL 5.25 Item 7,
4. Remove the pickup assembly, Figure 1.

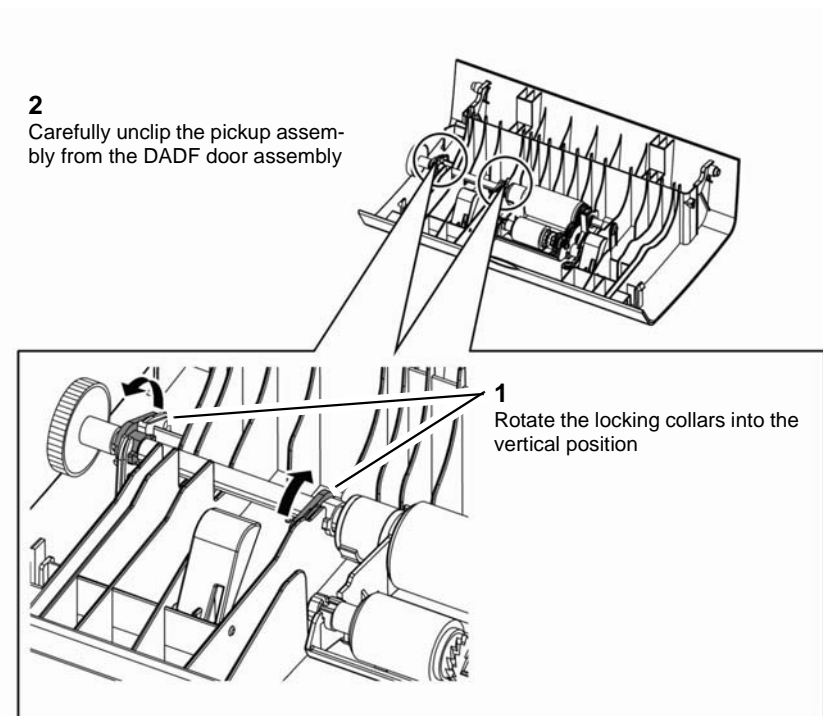

AP-1-1560-A

Figure 1 Pickup assembly removal

### Replacement

1. Ensure that the pickup assembly is correctly installed into the DADF door assembly, Figure 2.

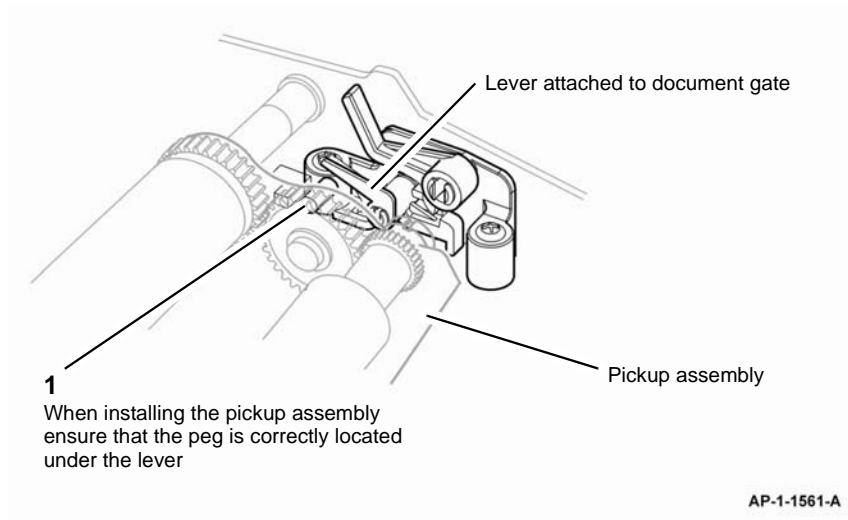

**Figure 2 Correct installation**

2. Replacement is the reverse of the removal procedure.

## REP 6.1 LSU

Parts List on PL 6.10

### Removal

#### WARNING

Switch off the electricity to the machine. Disconnect the power cord from the customer supply while performing tasks that do not need electricity. Electricity can cause death or injury. Moving parts can cause injury.

#### WARNING

Avoid exposure to laser beam. Invisible laser radiation.



#### CAUTION

*Before performing this procedure, refer to General Disassembly Precautions, GP 10.*

1. Remove the DADF, PL 5.10 Item 1.
2. Remove the UI assembly, REP 2.1.
3. Remove the scanner assembly, REP 14.1.
4. Remove the rear cover, REP 28.1.
5. Remove the outbin, REP 28.2.
6. Disconnect CN24 from the Main PWB.
7. Remove 4 screws, then remove the LSU, PL 6.10 Item 1.

### Replacement

1. Replacement is the reverse of the removal procedure.

## REP 6.2 LSU Interlock Switch

Parts List on PL 6.10

### Removal

#### WARNING

Switch off the electricity to the machine. Disconnect the power cord from the customer supply while performing tasks that do not need electricity. Electricity can cause death or injury. Moving parts can cause injury.

#### WARNING

Avoid exposure to laser beam. Invisible laser radiation.



#### CAUTION

*Before performing this procedure, refer to General Disassembly Precautions, GP 10.*

1. Remove the DADF, PL 5.10 Item 1.
2. Remove the UI assembly, REP 2.1.
3. Remove the scanner assembly, REP 14.1.
4. Remove the rear cover, REP 28.1.
5. Remove the outbin, REP 28.2.
6. Disconnect CN21 from the Main PWB.
7. Remove the LSU interlock switch, PL 6.10 Item 2.

### Replacement

1. Replacement is the reverse of the removal procedure.

## REP 7.1 Bypass Feed Assembly

Parts List on PL 7.10

### Removal

#### WARNING

Switch off the electricity to the machine. Disconnect the power cord from the customer supply while performing tasks that do not need electricity. Electricity can cause death or injury. Moving parts can cause injury.

#### CAUTION

Before performing this procedure, refer to *General Disassembly Precautions, GP 10*.

1. Remove the DADF, PL 5.10 Item 1.
2. Remove the UI assembly, REP 2.1.
3. Remove the scanner assembly, REP 14.1.
4. Remove the front cover assembly, PL 28.10 Item 7.
5. Remove the front mid cover, REP 28.3.
6. Disconnect CN37 from the Main PWB.
7. Remove the bypass feed assembly, Figure 1.

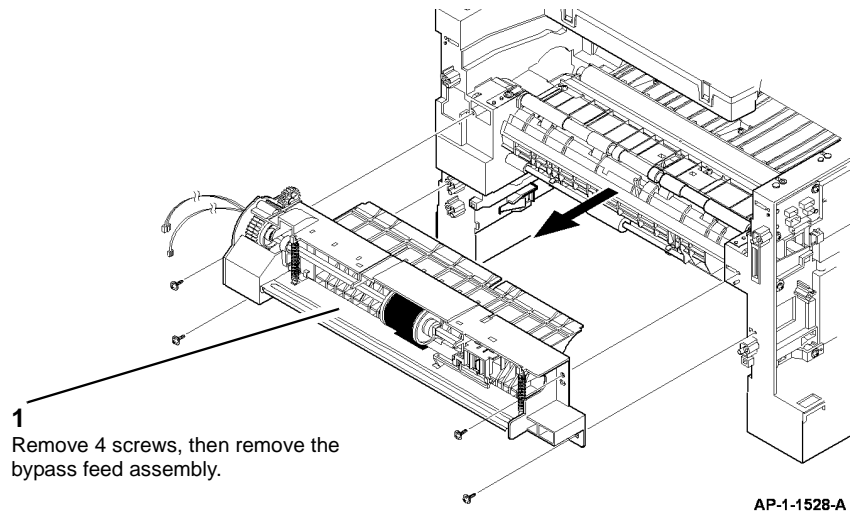

Figure 1 Bypass feed removal

### Replacement

1. Replacement is the reverse of the removal procedure.

## REP 7.2 Registration Solenoid and Tray 1 Pickup Solenoid

Parts List on PL 8.25

### Removal

#### WARNING

Switch off the electricity to the machine. Disconnect the power cord from the customer supply while performing tasks that do not need electricity. Electricity can cause death or injury. Moving parts can cause injury.

#### WARNING

Take care during this procedure. Sharp edges may be present that can cause injury.

#### CAUTION

Before performing this procedure, refer to *General Disassembly Precautions, GP 10*.

1. Remove the left cover, REP 28.1.
2. Remove the main drive assembly, refer to REP 4.1.
3. Disconnect CN36 on the Main PWB.
4. Remove the relevant component:
  - Tray 1 pickup solenoid, PL 8.25 Item 19.
  - Registration solenoid, PL 8.25 Item 18.

### Replacement

1. Replacement is the reverse of the removal procedure.

## REP 7.3 Bypass Pickup Roll

Parts List on PL 7.10

### Removal

#### WARNING

Switch off the electricity to the machine. Disconnect the power cord from the customer supply while performing tasks that do not need electricity. Electricity can cause death or injury. Moving parts can cause injury.

#### CAUTION

Before performing this procedure, refer to *General Disassembly Precautions, GP 10*.

1. Open the front cover assembly, PL 28.10 Item 7.
2. Remove the bypass pickup roll, refer to Figure 1. Perform the following:
  - a. Release the tab, then slide the locking collar to the left.
  - b. Move the pickup roll and the left idler to the left.
  - c. Rotate the pickup roll through 90 degrees to remove it from the shaft.

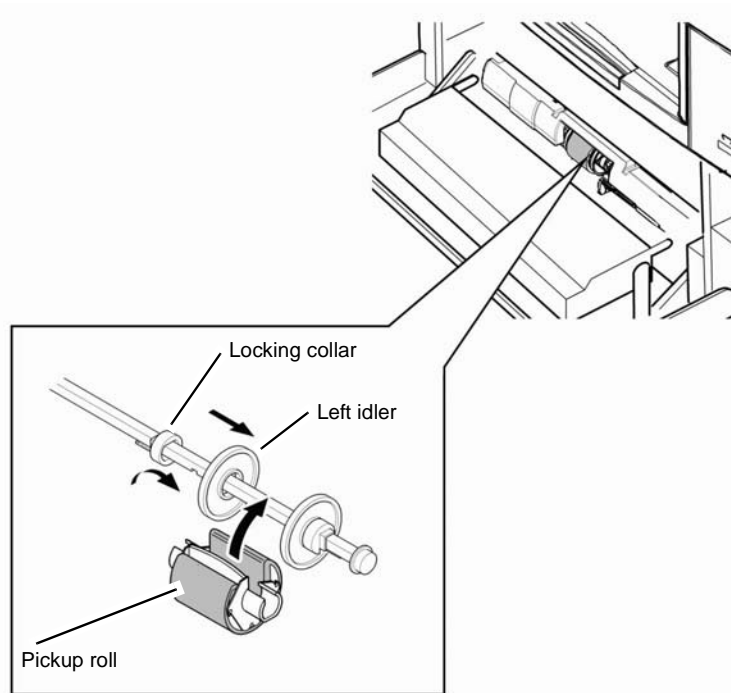

AP-1-1556-A

Figure 1 Pickup roll removal

### Replacement

1. Replacement is the reverse of the removal procedure.

## REP 7.4 Tray 2 Feed Motor and Pickup Solenoid

Parts List on PL 8.17

### Removal

#### WARNING

Switch off the electricity to the machine. Disconnect the power cord from the customer supply while performing tasks that do not need electricity. Electricity can cause death or injury. Moving parts can cause injury.

#### WARNING

Take care during this procedure. Sharp edges may be present that can cause injury.

#### CAUTION

Before performing this procedure, refer to *General Disassembly Precautions, GP 10*.

1. Remove the tray 2 module, PL 8.15 Item 28.
2. Remove 3 screws to release the tray 2 left cover, PL 8.15 Item 5.

#### CAUTION

Take care when releasing the tabs at the corners, they may be susceptible to breaking.

3. Use a flat bladed screwdriver to release the tabs underneath and then lift the panel off the pegs at the top.
4. Remove the drive assembly bracket, PL 8.15 Item 20.
5. Remove the tray 2 feed motor, PL 8.15 Item 23 or tray 2 pickup solenoid, PL 8.17 Item 24 as required.

### Replacement

#### WARNING

Ensure all ground leads are connected.

1. Replacement is the reverse of the removal procedure.

**NOTE:** When reinstalling the side panel, stand the tray on the rear panel and engage the lower tabs before snapping the top edge over the pegs.

## REP 7.5 Bypass Paper Empty Sensor

Parts List on PL 7.10

### Removal

#### WARNING

Switch off the electricity to the machine. Disconnect the power cord from the customer supply while performing tasks that do not need electricity. Electricity can cause death or injury. Moving parts can cause injury.

#### CAUTION

Before performing this procedure, refer to General Disassembly Precautions, GP 10.

1. Remove the DADF, PL 5.10 Item 1.
2. Remove the UI assembly, REP 2.1.
3. Remove the scanner assembly, REP 14.1.
4. Remove the left cover, right cover and rear cover, REP 28.1.
5. Remove the front cover assembly, PL 28.10 Item 7.
6. Remove the outbin assembly, REP 28.2.
7. Remove the front mid cover, REP 28.3.
8. Remove the bypass paper empty sensor, Figure 1.

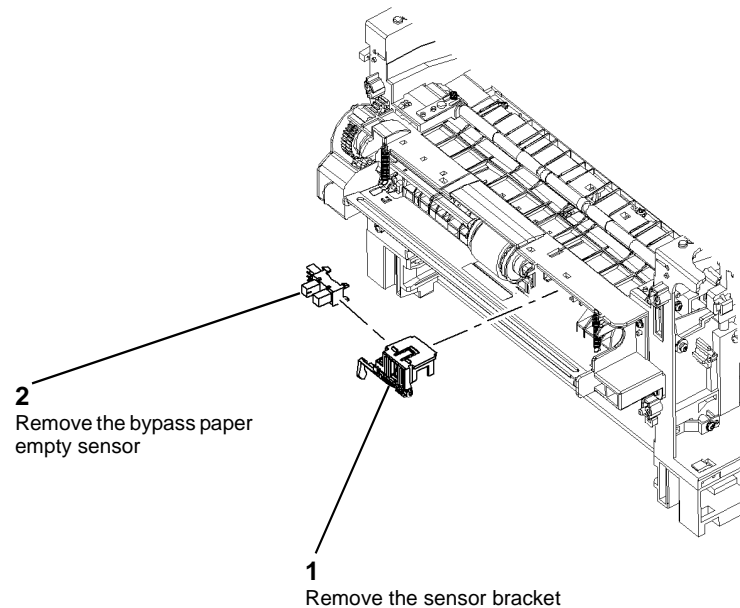

AP-1-1555-A

Figure 1 Sensor removal

### Replacement

1. Replacement is the reverse of the removal procedure.
2. If the harness is tight it may be necessary to remove the bypass feed assembly (REP 7.1) to allow sufficient slack to reinstall the sensor.

## REP 8.1 Registration Roll Clutch

### Parts List on PL 8.25

#### Removal

#### WARNING

Switch off the electricity to the machine. Disconnect the power cord from the customer supply while performing tasks that do not need electricity. Electricity can cause death or injury. Moving parts can cause injury.

#### WARNING

Take care during this procedure. Sharp edges may be present that can cause injury.

#### CAUTION

*Before performing this procedure, refer to General Disassembly Precautions, GP 10.*

1. Remove the left side cover, REP 28.1.
2. Remove the main motor, REP 4.1.
3. Remove the feed bracket, PL 8.25 Item 20.
4. Remove the registration roll clutch, PL 8.25 Item 21.

#### Replacement

1. Replacement is the reverse of the removal procedure.

## REP 9.1 CRUM PWB

### Parts List on PL 9.10

#### Removal

#### WARNING

Switch off the electricity to the machine. Disconnect the power cord from the customer supply while performing tasks that do not need electricity. Electricity can cause death or injury. Moving parts can cause injury.

#### WARNING

Take care during this procedure. Sharp edges may be present that can cause injury.

#### CAUTION

*Before performing this procedure, refer to General Disassembly Precautions, GP 10.*

1. Remove the DADF, PL 5.10 Item 1.
2. Remove the UI assembly, REP 2.1.
3. Remove the rear cover assembly, REP 28.1.
4. Remove the scanner assembly, REP 14.1.
5. Remove the outbin, REP 28.2.
6. Remove the LSU, REP 6.1.
7. Disconnect CN17 from the Main PWB.
8. Remove 1 screw, then the CRUM PWB, PL 9.10 Item 7.

#### Replacement

1. Replacement is the reverse of the removal procedure.

## REP 10.1 Duplex Motor

Parts List on PL 10.20

### Removal

#### WARNING

Switch off the electricity to the machine. Disconnect the power cord from the customer supply while performing tasks that do not need electricity. Electricity can cause death or injury. Moving parts can cause injury.

#### WARNING

Take care during this procedure. Sharp edges may be present that can cause injury.

#### CAUTION

Before performing this procedure, refer to General Disassembly Precautions, GP 10.

1. Remove the right cover, REP 28.1.
2. Remove the duplex drive assembly, PL 10.20 Item 13.
3. Remove the duplex motor, PL 10.20 Item 1 from the drive assembly.

### Replacement

1. Replacement is the reverse of the removal procedure.

## REP 10.2 Exit Motor

Parts List on PL 10.20

### Removal

#### WARNING

Switch off the electricity to the machine. Disconnect the power cord from the customer supply while performing tasks that do not need electricity. Electricity can cause death or injury. Moving parts can cause injury.

#### WARNING

Take care during this procedure. Sharp edges may be present that can cause injury.

#### CAUTION

Before performing this procedure, refer to General Disassembly Precautions, GP 10.

1. Remove the right cover, REP 28.1.
2. Disconnect the harness from the exit motor, PL 10.20 Item 4.
3. Remove the exit drive assembly, Figure 1.

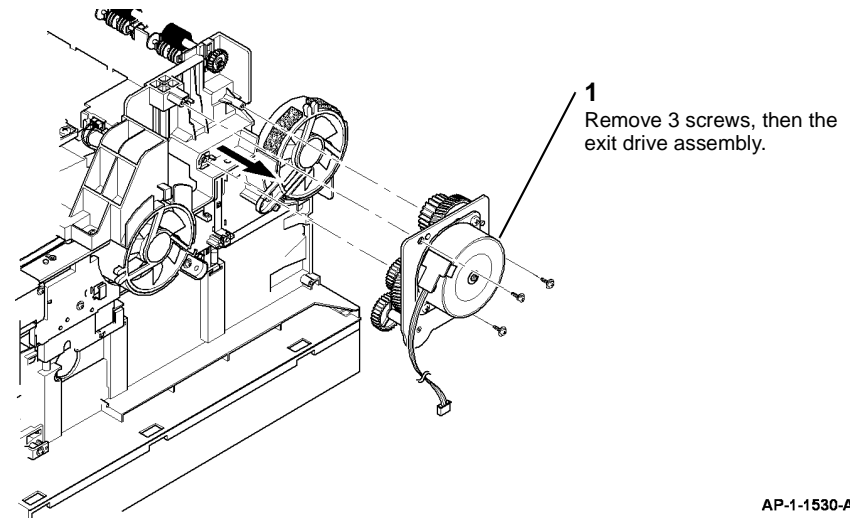

Figure 1 Exit drive assembly removal

4. Remove 4 gears from the exit drive assembly to gain access to the motor mounting screws, refer to PL 10.20.
5. Remove 2 screws to remove the exit motor from the exit motor bracket.

### Replacement

1. Replacement is the reverse of the removal procedure.

## REP 10.3 Front Duplex Guide Assembly

Parts List on PL 10.22

### Removal

#### WARNING

Switch off the electricity to the machine. Disconnect the power cord from the customer supply while performing tasks that do not need electricity. Electricity can cause death or injury. Moving parts can cause injury.

#### WARNING

Take care during this procedure. Sharp edges may be present that can cause injury.

#### CAUTION

Before performing this procedure, refer to *General Disassembly Precautions, GP 10*.

1. Remove tray 1.
2. Remove the duplex assembly, PL 10.23 Item 18.
3. Remove the DADF, PL 5.10 Item 1.
4. Remove the print cartridge, PL 9.10 Item 1.
5. Carefully lift the machine so that it rests on the rear cover.
6. Remove the tray 1 pick-up roll, PL 10.22 Item 14 by releasing the tab from the notch in the shaft.
7. Prepare to remove the front duplex guide assembly, Figure 1.

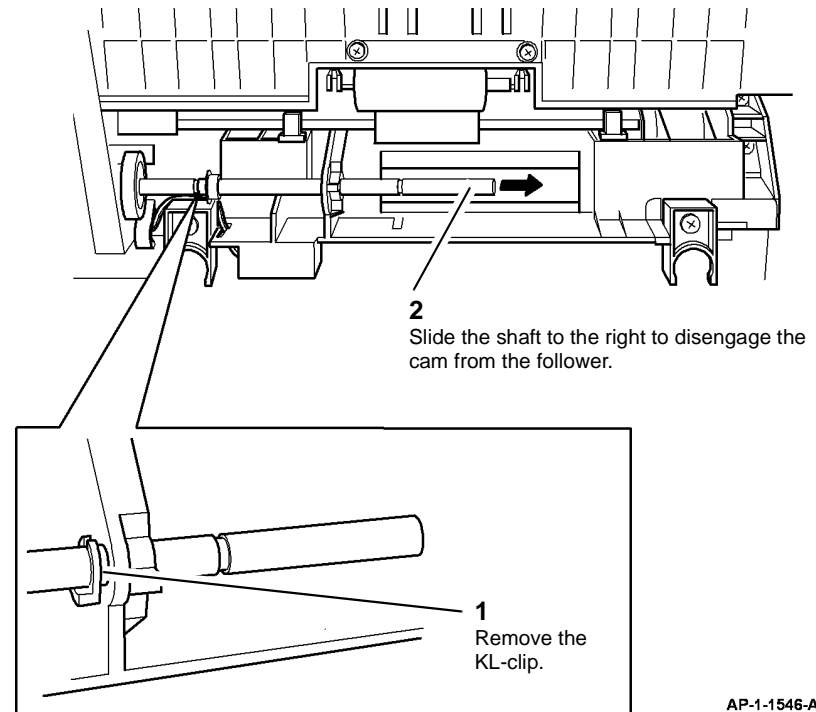

AP-1-1546-A

Figure 1 Preparation

8. Remove the front duplex guide assembly, Figure 2.

## REP 10.4 Exit Roll and Exit Idler Assemblies

Parts List on PL 10.25

### Removal

#### WARNING

Switch off the electricity to the machine. Disconnect the power cord from the customer supply while performing tasks that do not need electricity. Electricity can cause death or injury. Moving parts can cause injury.

#### CAUTION

Before performing this procedure, refer to *General Disassembly Precautions, GP 10*.

1. Remove the DADF, PL 5.10 Item 1.
2. Remove the left cover, right cover and rear cover, REP 28.1.
3. Remove the UI assembly, REP 2.1.
4. Remove the scanner assembly, REP 14.1.
5. Remove the exit cover assembly, PL 28.10 Item 2.
6. Remove the exit roll, PL 10.25 Item 22.
7. Remove the idler assembly, PL 10.25 Item 21 if required.

### Replacement

1. Replacement is the reverse of the removal procedure.

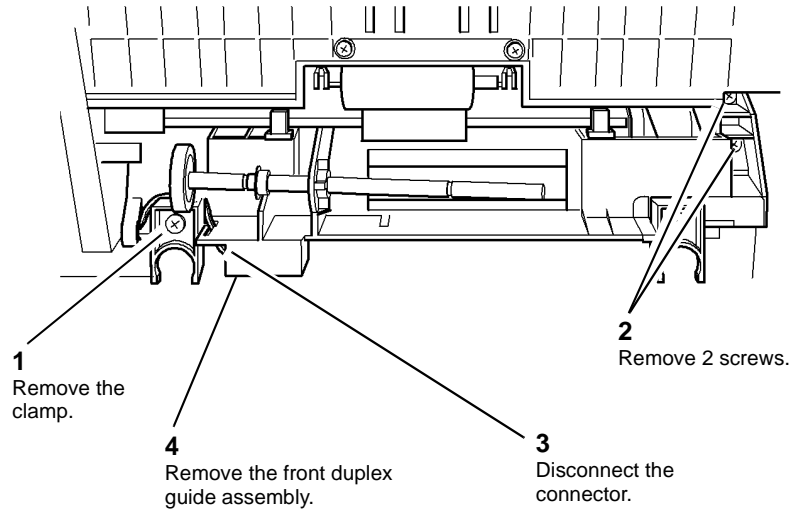

AP-1-1547-A

Figure 2 Front duplex guide assembly removal

9. If necessary remove the tray 1 paper empty sensor, PL 10.22 Item 1 from the front duplex guide.

### Replacement

1. Replacement is the reverse of the removal procedure.

## REP 10.5 Fuser Terminal

Parts List on PL 10.25

### Removal

#### WARNING

Switch off the electricity to the machine. Disconnect the power cord from the customer supply while performing tasks that do not need electricity. Electricity can cause death or injury. Moving parts can cause injury.

#### CAUTION

Before performing this procedure, refer to *General Disassembly Precautions, GP 10*.

1. Remove the DADF PL 5.10.
2. Remove the scanner REP 14.1.
3. Remove the rear cover and the left and right covers REP 28.1.
4. Remove the outbin REP 28.2.
5. Remove the LSU REP 6.1.
6. Disconnect CON2 from the SMPS, REP 1.1.
7. Disconnect CN19 from the Main PWB.
8. Remove the fuser terminal, PL 10.25 Item 8.
9. Disconnect the red and black harness from the fuser terminal.

### Replacement

1. Replacement is the reverse of the removal procedure.

## REP 10.6 Heat Lamp

Parts List on PL 10.15

### Removal

#### WARNING

Switch off the electricity to the machine. Disconnect the power cord from the customer supply while performing tasks that do not need electricity. Electricity can cause death or injury. Moving parts can cause injury.

#### CAUTION

Before performing this procedure, refer to *General Disassembly Precautions, GP 10*.

1. Remove the fuser assembly PL 10.10.
2. Remove the left and right lamp caps, PL 10.12 Item 2 and PL 10.12 Item 3.
3. Disconnect the harnesses from the heat lamp, Figure 1 and Figure 3.

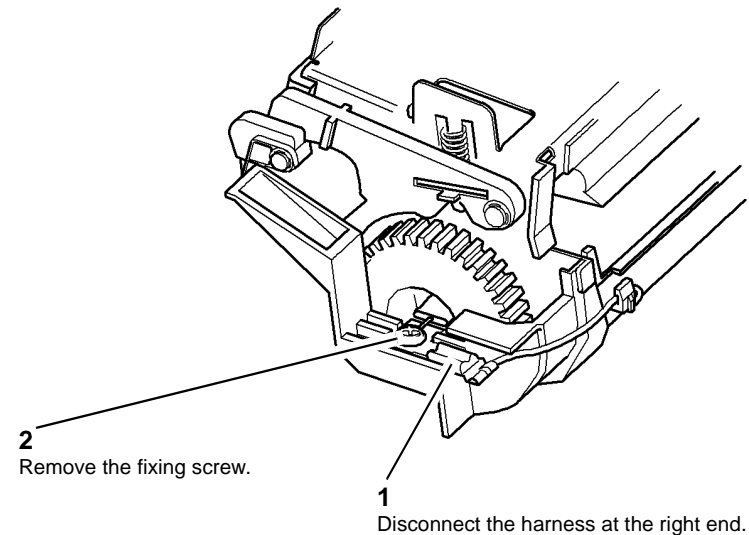

AP-1-1557-A

Figure 1 Right harness disconnection

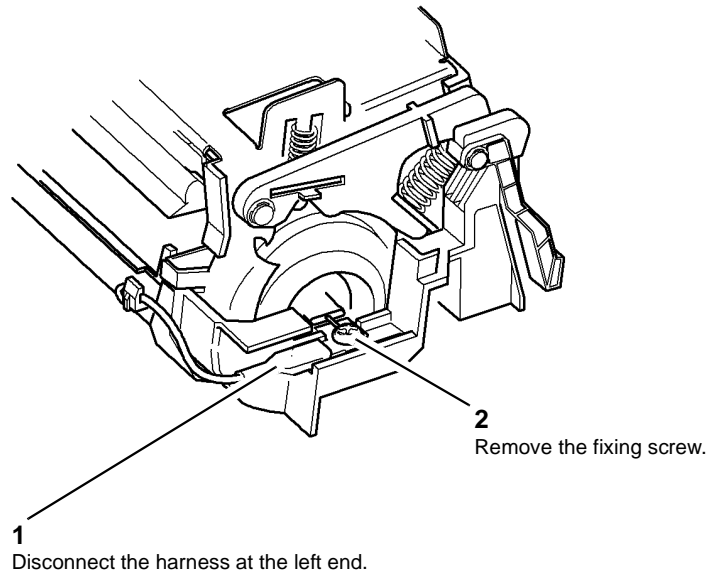

AP-1-1558-A

**Figure 2 Left harness disconnection**

4. Carefully remove the heat lamp from the fuser assembly by withdrawing it through the right end of the fuser, Figure 3.

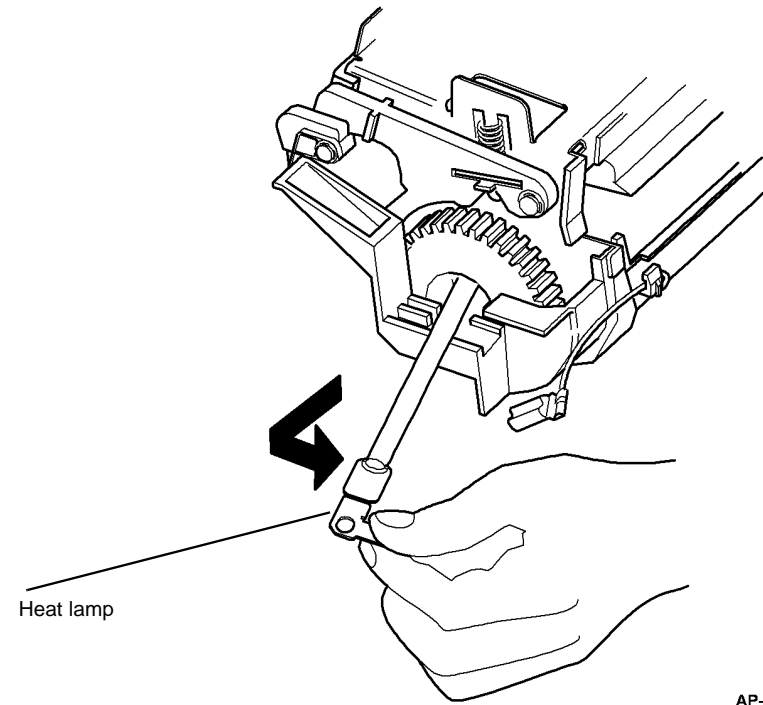

AP-1-1559A

**Figure 3 Heat lamp removal**

### **Replacement**

1. Replacement is the reverse of the removal procedure.

## REP 14.1 Scanner Assembly

### Parts List on PL 14.10

#### Removal

#### WARNING

Switch off the electricity to the machine. Disconnect the power cord from the customer supply while performing tasks that do not need electricity. Electricity can cause death or injury. Moving parts can cause injury.

#### CAUTION

Before performing this procedure, refer to General Disassembly Precautions, GP 10.

1. Remove the DADF, PL 5.10 Item 1.
2. Remove the UI assembly, REP 2.1.
3. Lock the CCD carriage.
4. Remove the rear cover assembly, left cover and right cover, REP 28.1.
5. Disconnect the following connectors from the Main PWB:
  - CN1
  - CN4
  - CN5
  - CN8
  - CN9
  - CN10
  - CN12
6. Remove the scanner assembly, Figure 1.

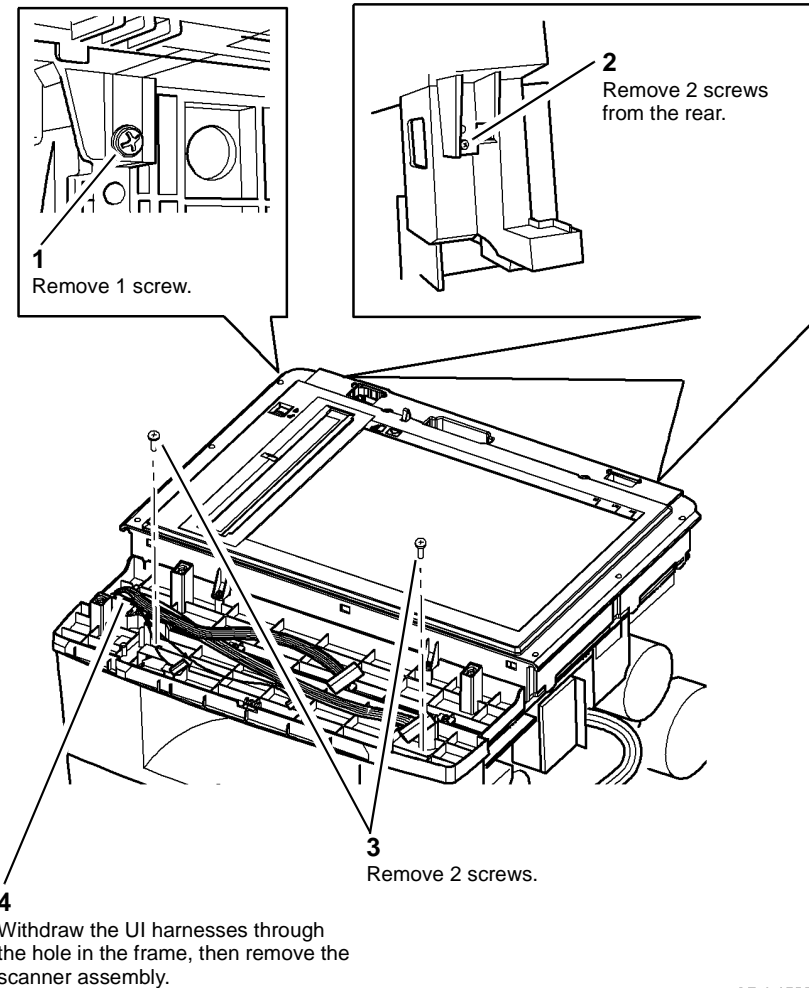

AP-1-1526-A

Figure 1 Scanner assembly removal

#### Replacement

1. Replacement is the reverse of the removal procedure.
2. When reconnecting the ribbon cable to the main board (CN8) the blue flash should face down.

## REP 14.2 Scanner Components

### Parts List on PL 14.10

#### Removal

#### WARNING

Switch off the electricity to the machine. Disconnect the power cord from the customer supply while performing tasks that do not need electricity. Electricity can cause death or injury. Moving parts can cause injury.

#### CAUTION

Before performing this procedure, refer to *General Disassembly Precautions, GP 10*.

1. Remove the DADF, PL 5.10 Item 1.
2. Remove the UI assembly, REP 2.1.

#### CAUTION

Do not allow the optics cavity to become contaminated. Contamination of the optics cavity can cause image quality defects.

3. Remove the scanner cover, Figure 1.

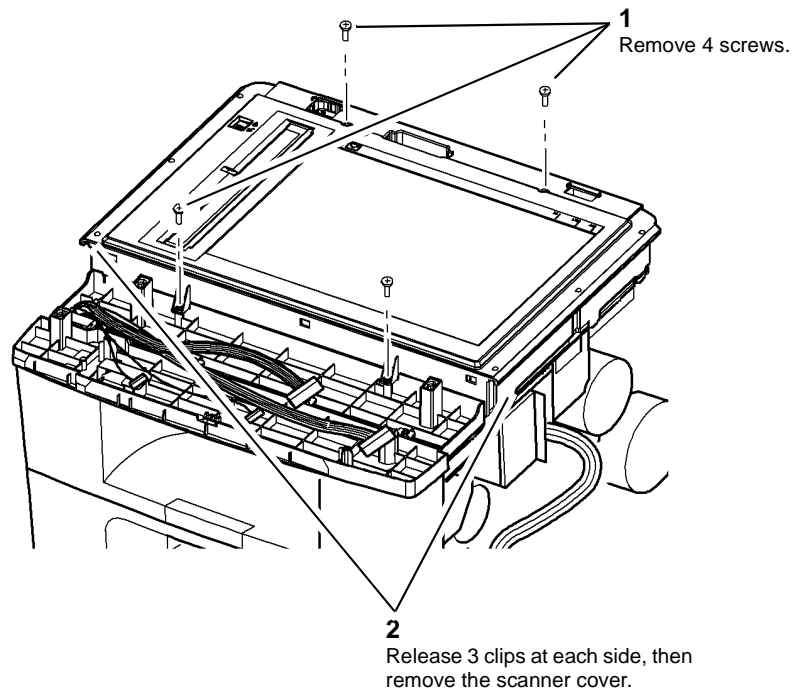

AP-1-1531-A

Figure 1 Scanner cover removal

4. If necessary, remove the CCD home sensor or the platen cover sensor, Figure 2.

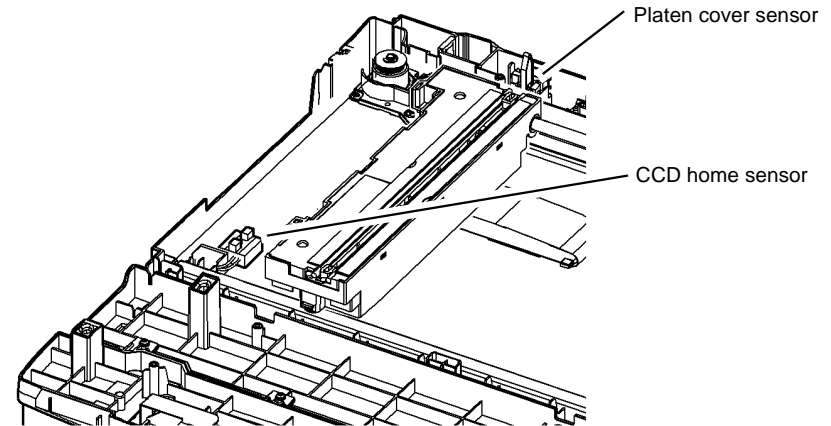

AP-1-1532-A

Figure 2 Sensor locations

5. If necessary, remove the CCD module, Figure 3.

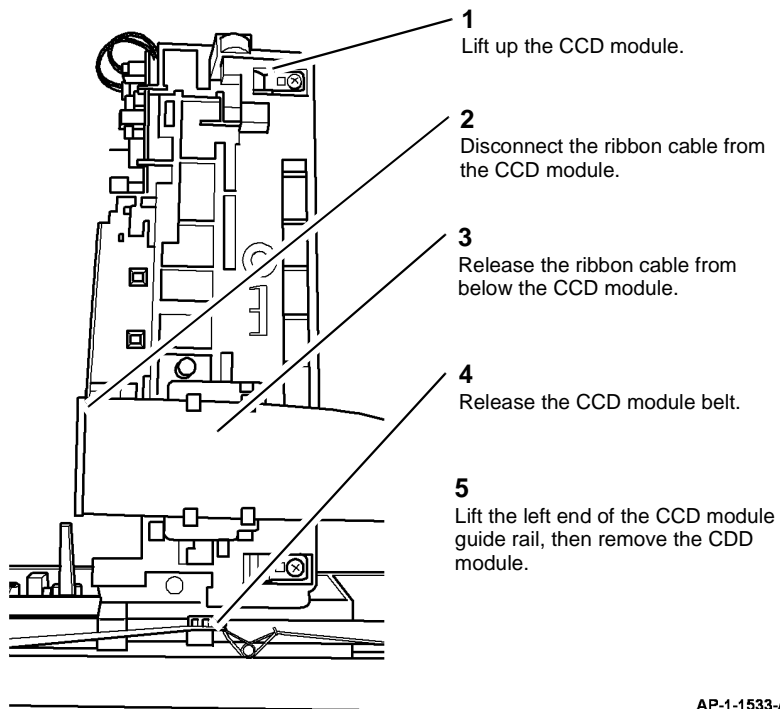

AP-1-1533-A

Figure 3 CCD module removal

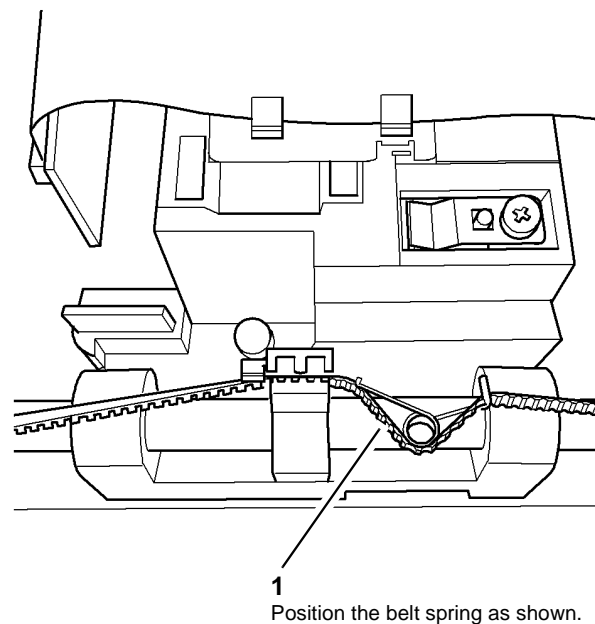

AP-1-1535-A

Figure 4 CCD module installation

6. If necessary, remove the scan motor drive assembly, PL 14.10 Item 6. Remove the scan motor, PL 14.10 Item 10 from the drive assembly.
7. If necessary, remove the CCD module belt, PL 14.10 Item 17.

### Replacement

1. Replacement is the reverse of the removal procedure.
2. When reconnecting the ribbon cable to the CCD module the blue flash should face the CCD module.
3. When reinstalling the CCD module, make sure the spring on the CCD module belt is positioned correctly, Figure 4.

## REP 28.1 External Covers

### Parts List on PL 28.10

#### Removal

#### WARNING

Switch off the electricity to the machine. Disconnect the power cord from the customer supply while performing tasks that do not need electricity. Electricity can cause death or injury. Moving parts can cause injury.

#### CAUTION

Before performing this procedure, refer to *General Disassembly Precautions, GP 10*.

1. Remove the duplex assembly, PL 10.23 Item 18.
2. Remove the DADF, PL 5.10 Item 1.
3. Remove tray 1 PL 8.10 Item 1.
4. Remove the tray 2 module if present, PL 8.15 Item 28.
5. Remove the rear cover assembly, PL 28.10 Item 5 by removing 4 screws.
6. Remove the left trim, PL 14.10 Item 24 and the right trim, PL 14.10 Item 25.
7. Remove the left cover or right cover as necessary, Figure 1.

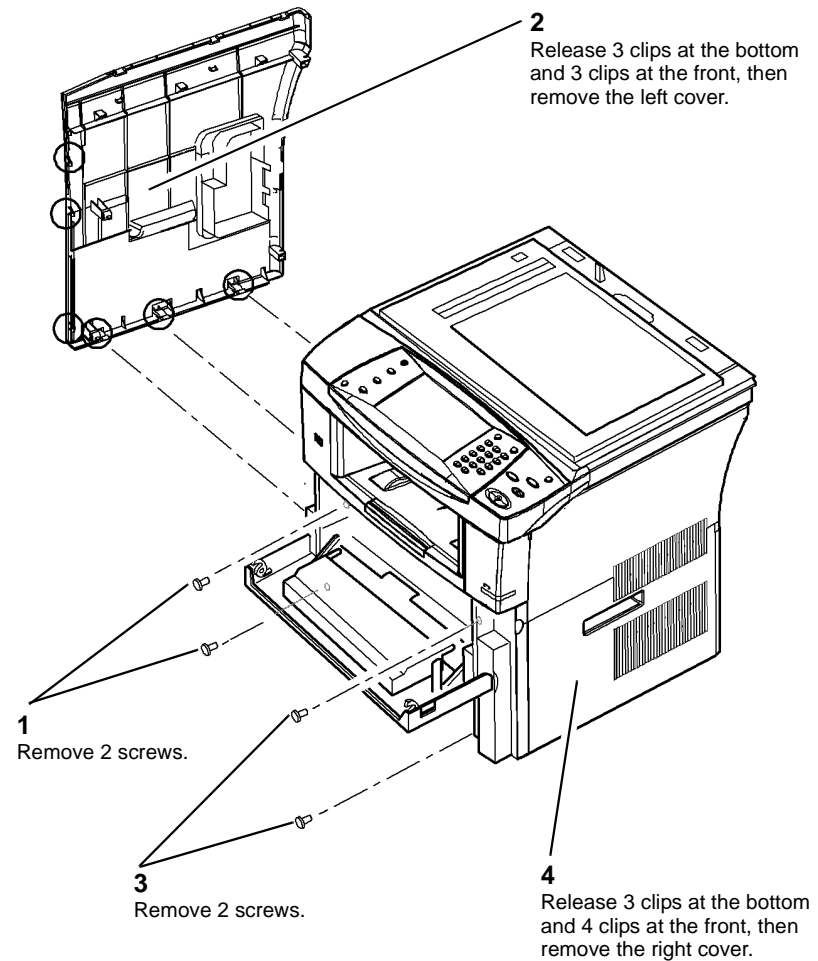

AP-1-1523-A

Figure 1 Left and right covers removal

#### Replacement

1. Replacement is the reverse of the removal procedure.

## REP 28.2 Outbin Assembly

### Parts List on PL 28.10

#### Removal

#### WARNING

Switch off the electricity to the machine. Disconnect the power cord from the customer supply while performing tasks that do not need electricity. Electricity can cause death or injury. Moving parts can cause injury.

#### WARNING

Take care during this procedure. Sharp edges may be present that can cause injury.

#### CAUTION

Before performing this procedure, refer to *General Disassembly Precautions, GP 10*.

1. Remove the DADF, PL 5.10 Item 1.
2. Remove the UI assembly, REP 2.1.
3. Remove the left cover, right cover and rear cover, REP 28.1.
4. Remove the scanner assembly, REP 14.1.
5. Remove the stapler assembly, PL 11.10 Item 4.
6. Disconnect the following harnesses from the Connection PWB:
  - CN7
  - CN1
  - CN2
7. Remove the exit cover assembly, PL 28.10 Item 2.
8. Disconnect the following harnesses from the Main PWB:
  - CN7
  - CN14
  - CN15
  - CN26
9. Prepare to remove the outbin assembly, Figure 1.

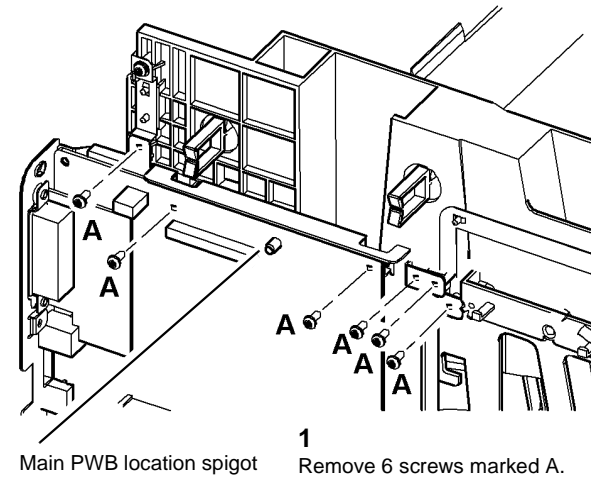

AP-1-1527-A

Figure 1 Preparation

#### CAUTION

Take care not to damage the main PWB location spigot when removing the outbin, refer to Figure 1. Also, take care not to move the exit roll and idlers.

10. Remove the outbin assembly, Figure 2.

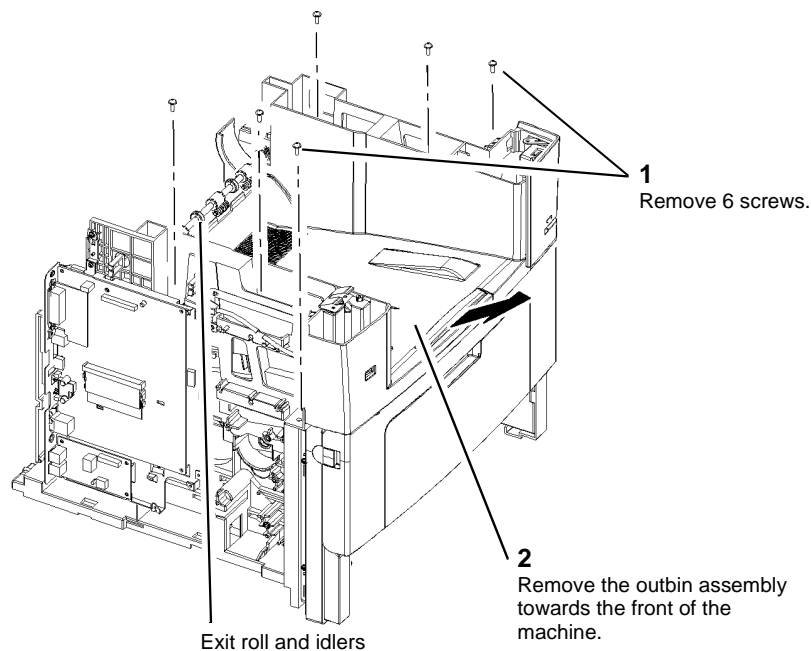

Figure 2 Outbin assembly removal

AP-1-1549-A

## REP 28.3 Front Mid Cover

Parts List on PL 28.10

### Removal

#### WARNING

Switch off the electricity to the machine. Disconnect the power cord from the customer supply while performing tasks that do not need electricity. Electricity can cause death or injury. Moving parts can cause injury.

#### WARNING

Take care during this procedure. Sharp edges may be present that can cause injury.

#### CAUTION

Before performing this procedure, refer to *General Disassembly Precautions, GP 10*.

1. Remove the DADF, PL 5.10 Item 1.
2. Remove the UI assembly, REP 2.1.
3. Remove the left cover, right cover and rear cover, REP 28.1.
4. Remove the scanner assembly, REP 14.1.
5. Remove the front cover assembly, PL 28.10 Item 7.
6. Remove the 12 screws that secure the outbin assembly, refer to REP 28.2.
7. Remove the 4 screws that secure the front mid cover, PL 28.10 Item 6.
8. Carefully lift the front of the outbin assembly, then remove the front mid cover.

### Replacement

1. Replacement is the reverse of the removal procedure.

### Replacement

1. Replacement is the reverse of the removal procedure.

## **ADJ 1.1 Machine Settings**

### **Purpose**

To correctly set up the machine.

### **Procedure**

All adjustments to the machines settings are made via dC131 NVM Read/Write and GP 4 System Administration Tools. Go to the relevant procedure.

## ADJ 5.1 DADF Side Edge Registration Adjustment

### Purpose

To correctly set the DADF side edge registration.

### Procedure

Perform the following:

1. Remove the input tray assembly, PL 5.15 Item 2.
2. Remove the lower cover, PL 5.15 Item 1.
3. Carefully move both document guides to the front or the rear to adjust the registration.

***NOTE:** Moving both document guides 1 tooth on the pinion gear will adjust the registration by approximately 3mm (0.1 inch).*

4. Assemble the input tray assembly.
5. Use the DADF to make 10 copies of a document. Check the registration, refer to IQS 3 Registration. If necessary, re-adjust the registration.

## ADJ 8.1 Lead Edge Registration Adjustment

### Purpose

To measure and adjust lead edge image to paper registration.

### Check

**NOTE:** Both the Check and the Adjustment use an internal test pattern. Both are performed in diagnostics.

Check the lead edge registration (top edge of portrait A4 or 8.5x11 inch). Perform the following:

1. Enter dC606 Internal Print Test Patterns.
2. Select test pattern 7.
3. Select **Features**. For simplex lead edge check, select **1 Sided**. For duplex lead edge check select, **2 Sided**.
4. Select the tray. Select **Start Test**.

**NOTE:** Simplex copies exit face down. Duplex copies exit side 1 face down (side 2 face up).

5. Measure the distance between the lead edge of the paper and the ABC line on the printed test pattern, Figure 1.



AP-1-1543-A

Figure 1 Test pattern 7

6. If the distance measured is not 12.7mm (0.5 inch) +/-3mm (1/8 inch), perform the Adjustment.

### Adjustment

1. Select **Exit** (on the dC606 Internal Print Test Patterns screen).
2. Select **Diagnostic Routines**.
3. Select **Copier Routines**.
4. Select **131 NVM Read Write**.
5. Refer to Table 1. Select the relevant NVM setting.

Table 1 NVM location

Mode	Tray	Location
Simplex	1	07-100
Simplex	2	07-200
Simplex	Bypass	07-500
Duplex Side 1	1	07-140
Duplex Side 1	2	07-240

Table 1 NVM location

Mode	Tray	Location
Duplex Side 1	Bypass	07-520
Duplex Side 2	1	07-120
Duplex Side 2	2	07-220

6. Select **Read/Write**. Enter a new value as follows:
  - To increase the lead edge registration (move the ABC line away from the paper edge), enter a value larger than the current value.
  - To decrease the lead edge registration (move the ABC line toward the paper edge), enter a value smaller than the current value.

***NOTE:** A change of 12 will change the registration by approximately 1mm (0.04 inch)*
7. Save the adjustment.
  - a. Select **Save**.
  - b. Select **OK**.
8. Prepare to check the adjustment.
  - a. Select **Close**.
  - b. Select **Diagnostic Routines**.
  - c. Select **Other Routines**.
9. Perform again the Check.

## ADJ 8.2 Side Edge Registration Adjustment

### Purpose

To measure and adjust side edge image to paper registration.

### Check

***NOTE:** Both the Check and the Adjustment use an internal test pattern. Both are performed in diagnostics.*

Check the side edge registration (left side edge of portrait A4 or 8.5x11 inch). Perform the following:

1. Enter dC606 Internal Print Test Patterns.
2. Select test pattern 7.
3. Select **Features**. For simplex side edge check, select **1 Sided**. For duplex side edge check select, **2 Sided**.
4. Select the tray. Select **Start Test**.

***NOTE:** Simplex copies exit face down. Duplex copies exit side 1 face down (side 2 face up).*

- Measure the distance between the lead edge of the paper and the ADG line on the printed test pattern, Figure 1.

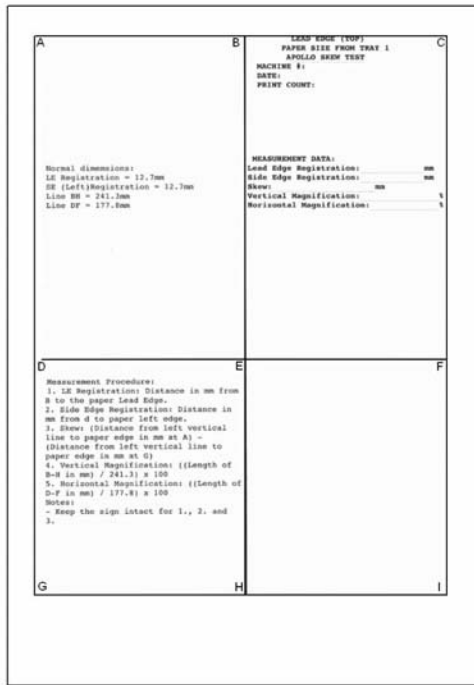

Figure 1 Test pattern 7

AP-1-1544-A

- If the distance measured is not 12.7mm (0.5 inch) +/-3mm (1/8 inch), perform the Adjustment.

### Adjustment

- Select **Exit** (on the dC606 Internal Print Test Patterns screen).
- Select **Diagnostic Routines**.
- Select **Copier Routines**.
- Select **131 NVM Read Write**.
- Refer to Table 1. Select the relevant NVM setting.

Table 1 NVM location

Mode	Tray	Location
Simplex	1	07-110
Simplex	2	07-210
Simplex	Bypass	07-510

Table 1 NVM location

Mode	Tray	Location
Duplex Side 1	1	07-150
Duplex Side 1	2	07-250
Duplex Side 1	Bypass	07-550
Duplex Side 2	1	07-130
Duplex Side 2	2	07-230

- Select **Read/Write**. Enter a new value as follows:
  - To increase the side edge registration (move the ADG line away from the paper edge), enter a value larger than the current value.
  - To decrease the side edge registration (move the ADG line toward the paper edge), enter a value smaller than the current value.

*NOTE: A change of 12 will change the registration by approximately 1mm (0.04 inch)*
- Save the adjustment.
  - Select **Save**.
  - Select **OK**.
- Prepare to check the adjustment.
  - Select **Close**.
  - Select **Diagnostic Routines**.
  - Select **Other Routines**.
- Perform again the Check.

# 5 Parts List

## PL 1 - Standby Power

PL 1.10 HVPS.....	5-3
PL 1.12 SMPS.....	5-4

## PL 2 - User Interface

PL 2.10 User Interface .....	5-5
------------------------------	-----

## PL 3 - Machine Run Control

PL 3.10 Main PWB and Main Drive Assembly .....	5-6
--	-----

## PL 4 - Main Drive Assembly

PL 4.10 Main Drive Assembly .....	5-7
-----------------------------------	-----

## PL 5 - DADF

PL 5.10 DADF (1 of 7).....	5-8
PL 5.15 DADF (2 of 7).....	5-9
PL 5.20 DADF (3 of 7).....	5-10
PL 5.25 DADF (4 of 7).....	5-11
PL 5.30 DADF (5 of 7).....	5-12
PL 5.35 DADF (6 of 7).....	5-13
PL 5.40 DADF (7 of 7).....	5-14

## PL 6 - Imaging

PL 6.10 LSU.....	5-15
------------------	------

## PL 7 - Paper Supply

PL 7.10 Bypass Feed Assembly (1 of 2).....	5-16
PL 7.12 Bypass Feed Assembly (2 of 2).....	5-17
PL 7.15 Front Cover Assembly .....	5-18

## PL 8 - Paper Transport

PL 8.10 Paper Tray.....	5-19
PL 8.15 Tray 2 Assembly (1 of 2).....	5-20
PL 8.17 Tray 2 Assembly (2 of 2).....	5-21
PL 8.20 Rear Cover Assembly.....	5-22
PL 8.25 Registration Rolls.....	5-23

## PL 9 - Xerographics

PL 9.10 Print Cartridge.....	5-24
------------------------------	------

## PL 10 - Fusing and Copy/Print Transportation

PL 10.10 Fuser Assembly (1 of 3).....	5-25
PL 10.12 Fuser Assembly (2 of 3).....	5-26
PL 10.15 Fuser Assembly (3 of 3).....	5-27
PL 10.20 Duplex Drive Assembly.....	5-28
PL 10.22 Front Duplex Guide Assembly .....	5-29
PL 10.23 Duplex Assembly (1 of 3).....	5-30
PL 10.25 Exit Feed Assembly .....	5-31
PL 10.30 Exit Cover Assembly.....	5-32

## PL 11 - Stapler Assembly

PL 11.10 Stapler Assembly .....	5-33
---------------------------------	------

## PL 14 - Scanner

PL 14.10 Scanner Assembly .....	5-34
---------------------------------	------

## PL 28 - Main Covers

PL 28.10 Main Covers.....	5-35
---------------------------	------

# PL 1.10 HVPS

Item	Part	Description
1	-	Tray 1 paper empty sensor harness (Not Spared)
2	-	HVPS harness (Not Spared)
3	105N02141	HVPS (REP 1.2)
4	-	HVPS insulation sheet (Not Spared)
5	-	HVPS shield (Not Spared)
6	-	HVPS assembly (Not Spared)

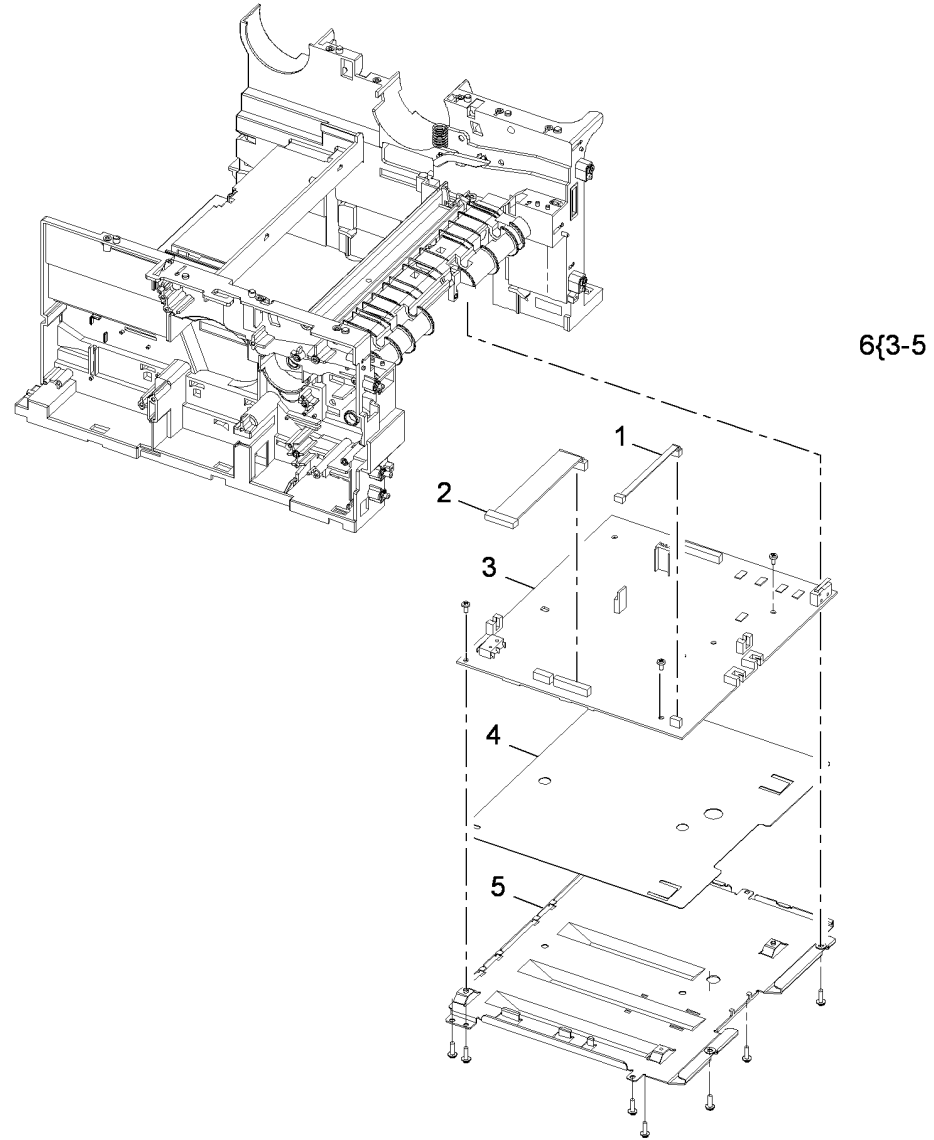

AP-8-1500-A

## PL 1.12 SMPS

Item	Part	Description
1	127N07354	SMPS fan
2	-	SMPS cover (Not Spared)
3	105N02119	SMPS (110V) (REP 1.1)
-	105N02143	SMPS (220V) (REP 1.1)
4	-	SMPS harness (Not Spared)
5	-	SMPS insulation sheet (Not Spared)
6	-	Main power socket (Not Spared)
7	-	SMPS shield (Not Spared)
8	-	SMPS assembly (Not Spared)
9	127N07559	Main fan

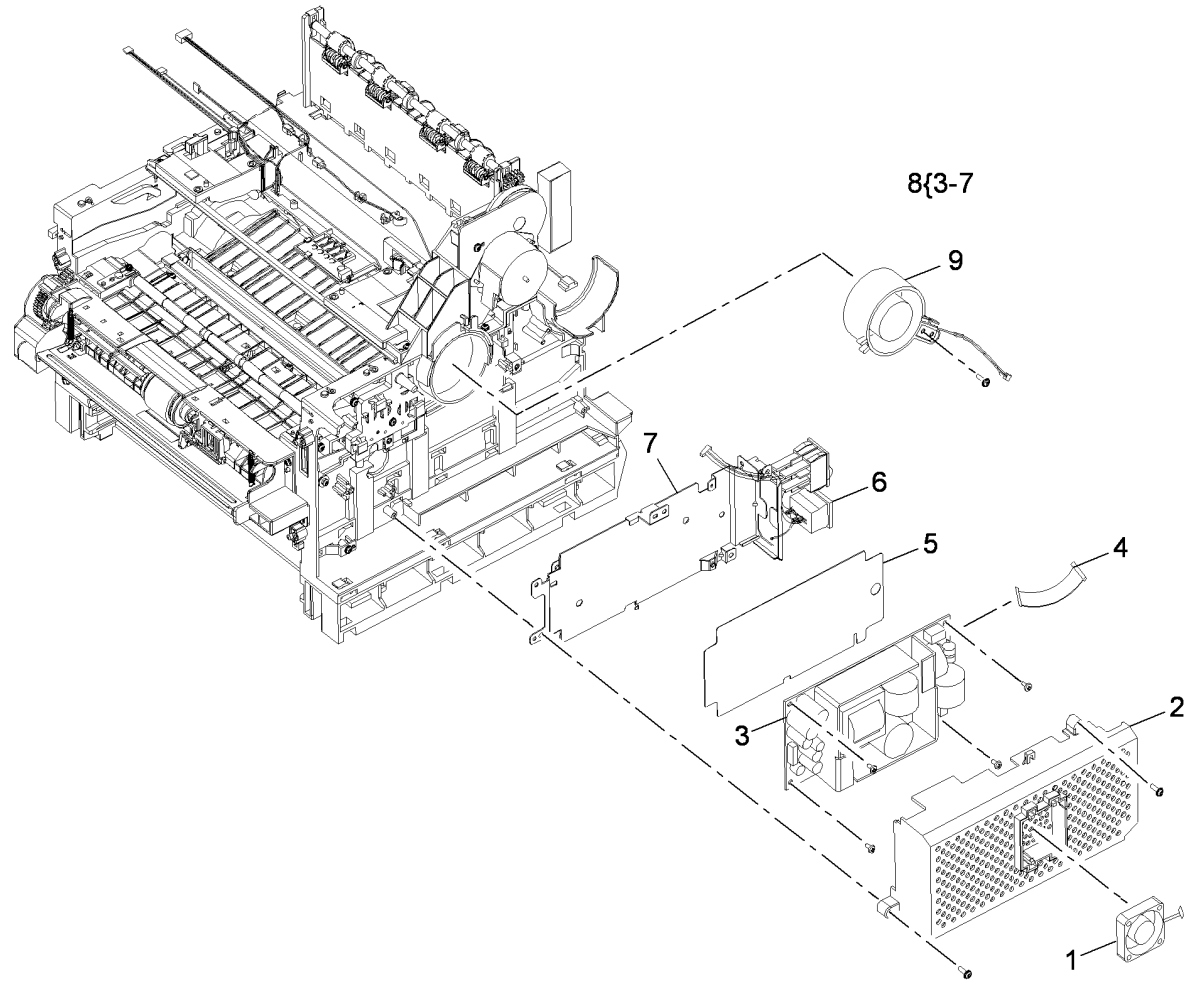

AP-8-1532-A

## PL 2.10 User Interface

Item	Part	Description
1	140N63296	Front cover panel
2	-	Key harness (P/O PL 2.10 Item 27)
3	-	Sub-key harness (P/O PL 2.10 Item 27)
4	091N80272	Start button label (English)
-	091N80276	Start button label (French)
-	091N80275	Start button label (Symbol)
5	-	Housing (P/O PL 2.10 Item 27)
6	029N00384	Language key
7	029N00385	Machine status key
8	029N00386	Login/out key
9	029N00387	Help key
10	029N00388	Numerical keys
11	029N00389	Power key
12	029N00390	Power key holder
13	029N00391	Interrupt key
14	029N00392	Job interrupt key
15	029N00393	Stop key
16	029N00394	Start key
17	029N00396	Rubber key mat (left hand side)
18	029N00397	Rubber key mat (right hand side)
19	140N63295	Right keys PWB
20	-	Left keys PWB (P/O PL 2.10 Item 27)
21	091N80273	Services label (English)
-	091N80278	Services label (French)
-	091N80277	Services label (Symbol)
22	091N80274	Numeric key pad label (English)
-	091N80280	Numeric key pad label (French)
-	091N80279	Numeric key pad label (Symbol)
23	015N00618	Name label
24	140N63294	UI PWB (REP 2.2)
25	123N00250	Touch screen (REP 2.2)
26	-	Touchscreen housing (P/O PL 2.10 Item 27)
27	123N00251	UI assembly (Complete) (REP 2.1)

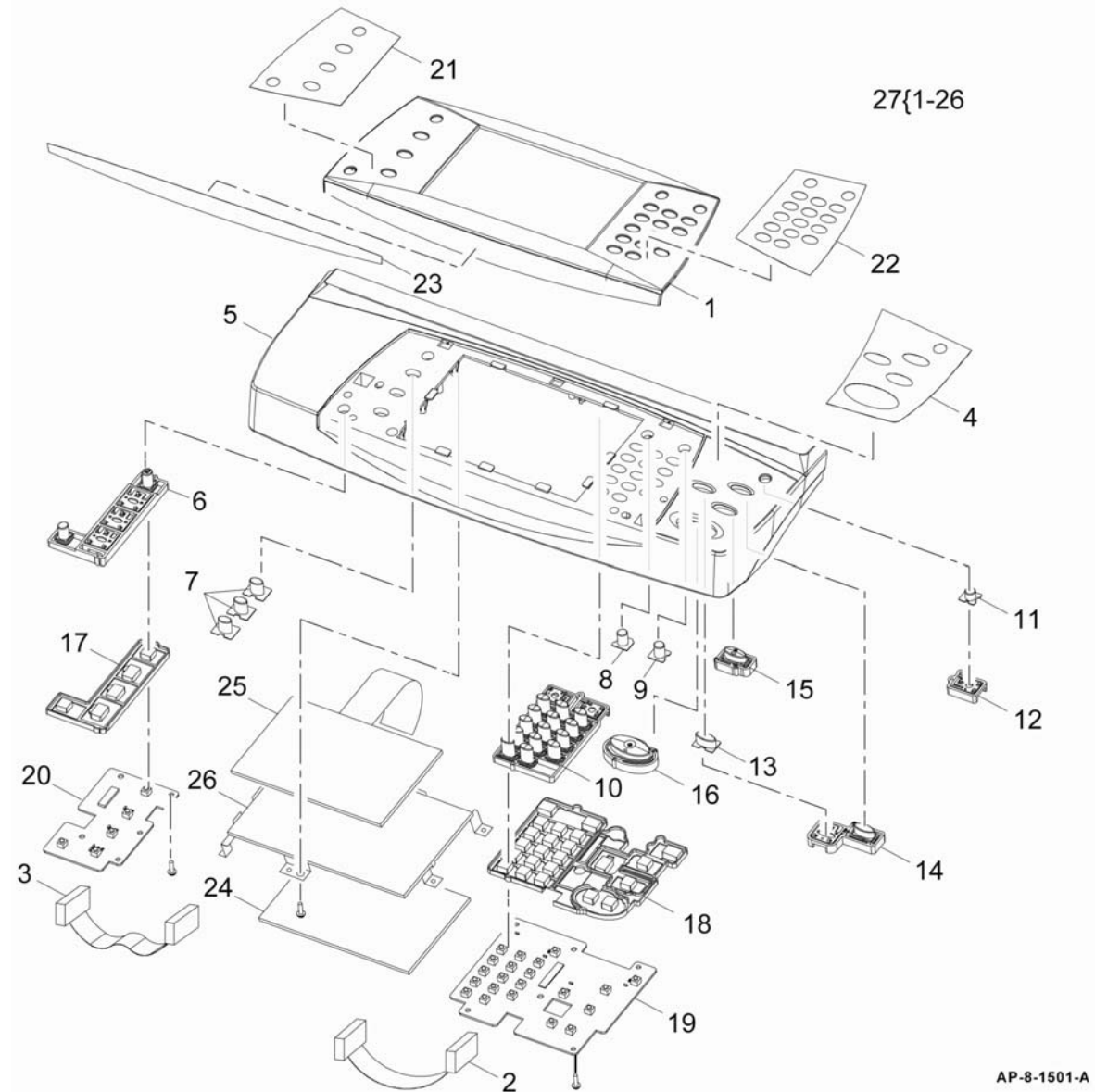

## PL 3.10 Main PWB and Main Drive Assembly

Item	Part	Description
1	-	Main drive assembly (REF: PL 4.10 Item 7)
2	130N01532	Speaker
3	140N63305	FAX PWB (Serial)
-	140N63304	FAX PWB (Parallel)
4	-	FAX harness (Not Spared)
5	-	FAX cover (Not Spared)
6	140N63297	Main PWB (REP 3.1)
7	-	Foreign device interface PWB (Note)
8	113N01308	SIM card holder
9	-	Main PWB bracket (Not Spared)
10	140N63298	Memory DIMM
11	140N63299	USB host PWB (REP 3.2)
12	-	Ground strip (Not Spared)
13	117N01789	USB harness (REP 3.2)
14	-	MSOK (Not Spared)
15	-	Hard drive cover (Not Spared)
16	007N01596	Hard disk drive
17	140N63303	Connection PWB

**NOTE:** Part number not available at time of launch.

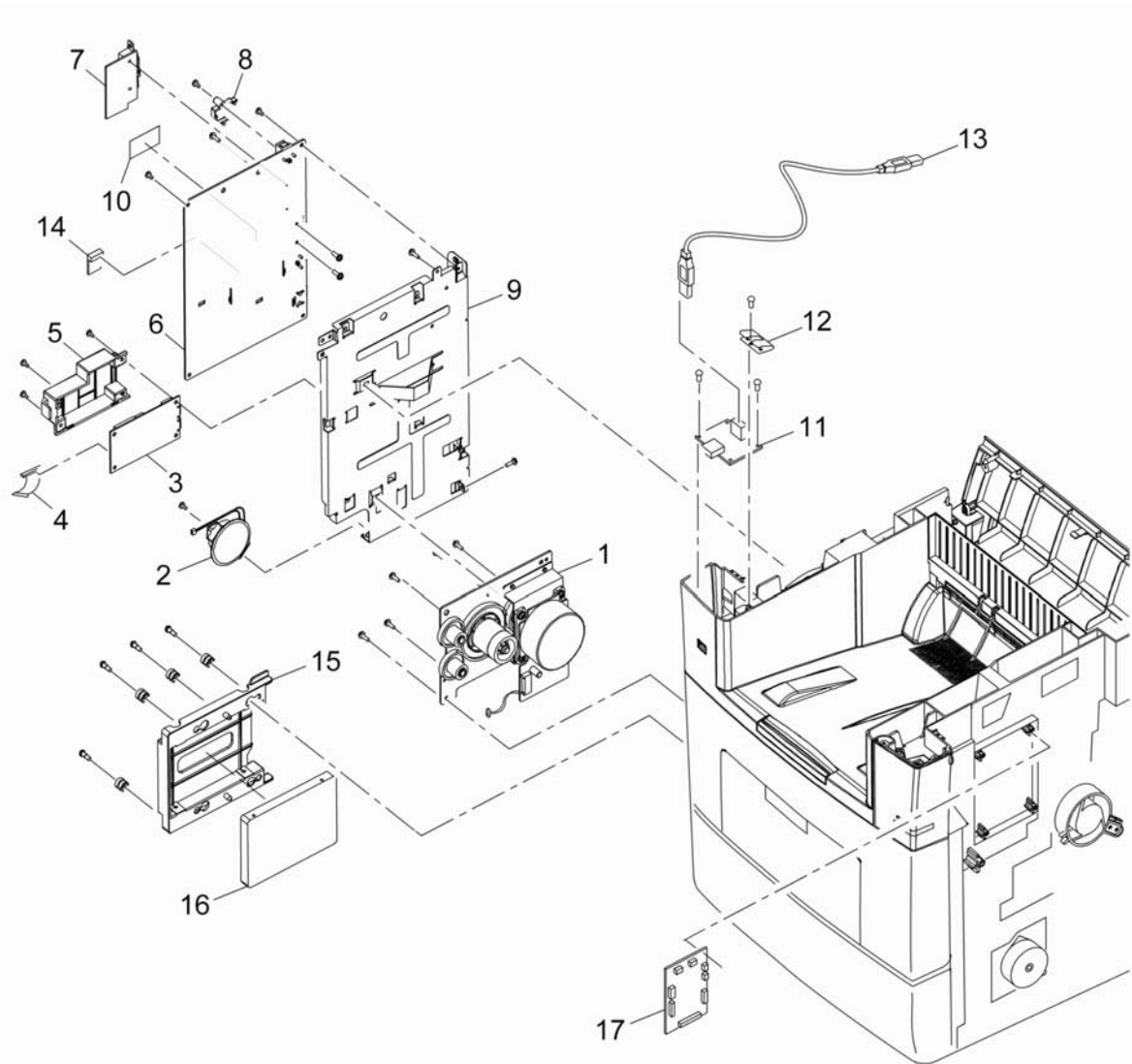

AP-8-1533-A

## PL 4.10 Main Drive Assembly

Item	Part	Description
1	127N07557	Main BLDC motor (MOT04-100) (REP 4.1)
2	-	Gear bracket (P/O PL 4.10 Item 7)
3	-	Motor bracket (P/O PL 4.10 Item 7)
4	-	Gear (92/61) (P/O PL 4.10 Item 7)
5	-	Gear (113/33) (P/O PL 4.10 Item 7)
6	-	Gear (55/18) (P/O PL 4.10 Item 7)
7	007N01591	Main drive assembly (REP 4.1)

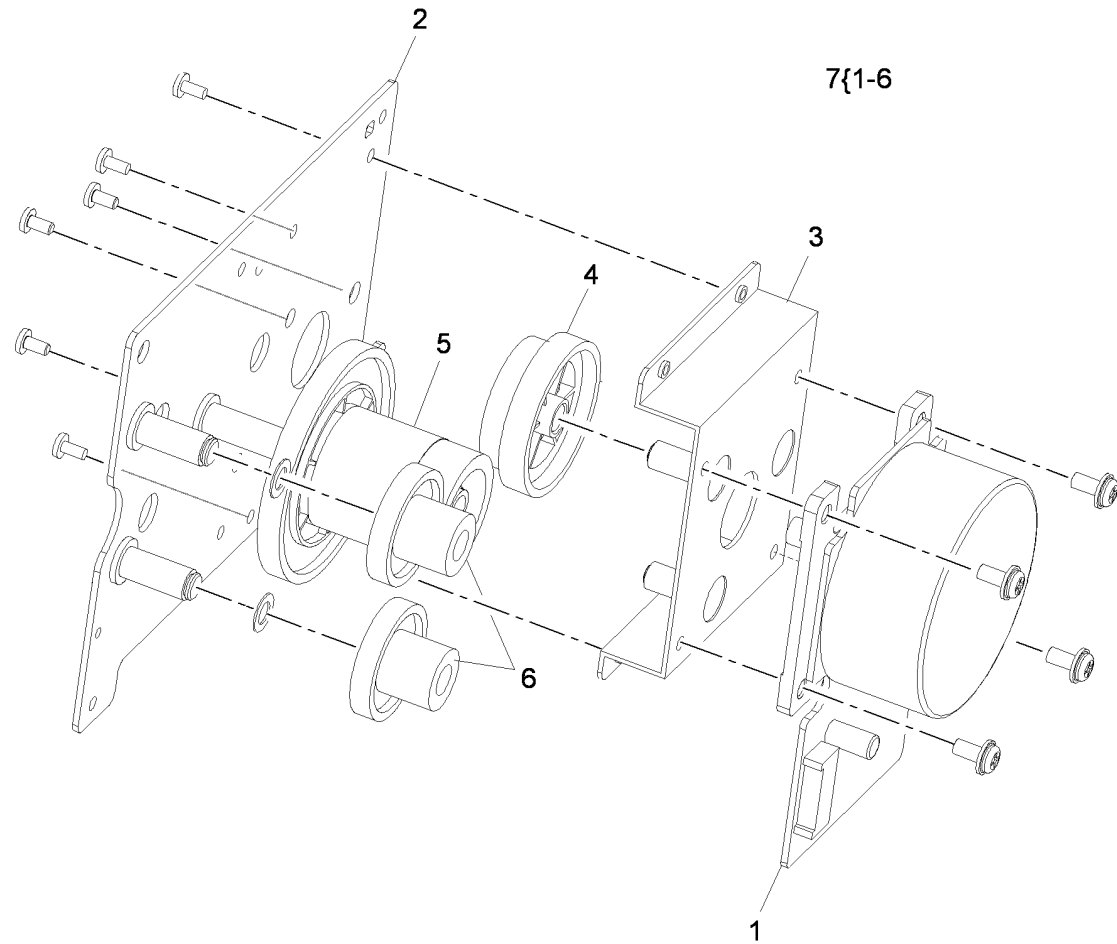

AP-8-1502-A

## PL 5.10 DADF (1 of 7)

Item	Part	Description
1	101N01421	DADF (Complete)
2	-	DADF lower cover assembly (P/O PL 5.10 Item 1)
3	-	DADF door assembly (REF: PL 5.25 Item 1)
4	-	Feed assembly (REF: PL 5.30 Item 1)
5	-	Drive assembly (REF: PL 5.40 Item 1)
6	-	Transport assembly (REF: PL 5.35 Item 14)
7	003N01031	Left counterbalance
8	003N01018	Right counterbalance
9	-	Rear cover (P/O PL 5.10 Item 1)
10	-	Front cover (P/O PL 5.10 Item 1)
11	002N02720	Connector cover
12	152N11751	DADF harness

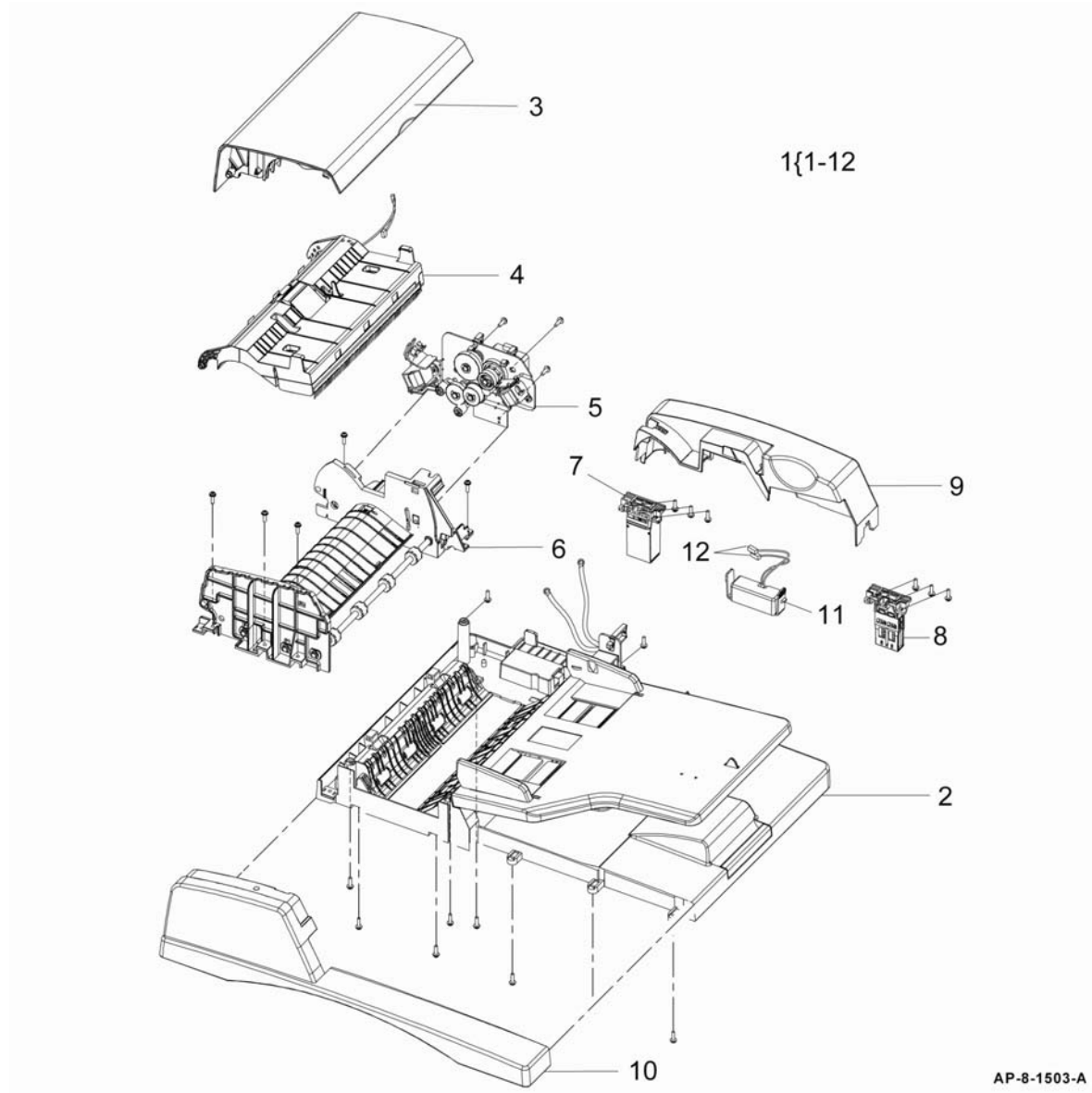

## PL 5.15 DADF (2 of 7)

Item	Part	Description
1	–	Lower cover (P/O PL 5.10 Item 1)
2	–	Input tray assembly (REF: PL 5.20 Item 13)
3	–	Solenoid damper (P/O PL 5.10 Item 1)
4	121N01160	DADF lift solenoid (SOL05-320) (REP 5.2)
5	–	Tray extension (P/O PL 5.10 Item 1)
6	–	Ground strip (P/O PL 5.10 Item 1)
7	095N00340	Document pad
8	–	Registration roll idler (P/O PL 5.10 Item 1)
9	–	Scan idler (P/O PL 5.10 Item 1)
10	–	Scan idler spring (P/O PL 5.10 Item 1)
11	–	Registration roll shaft (P/O PL 5.10 Item 1)
12	–	Nip release lever (P/O PL 5.10 Item 1)
13	–	Nip release lever spring (P/O PL 5.10 Item 1)
14	–	CVT pad (P/O PL 5.10 Item 1)
15	–	Lifting exit lever (P/O PL 5.10 Item 1)
16	140N63301	DADF PWB
17	–	DADF PWB harness (P/O PL 5.10 Item 1)

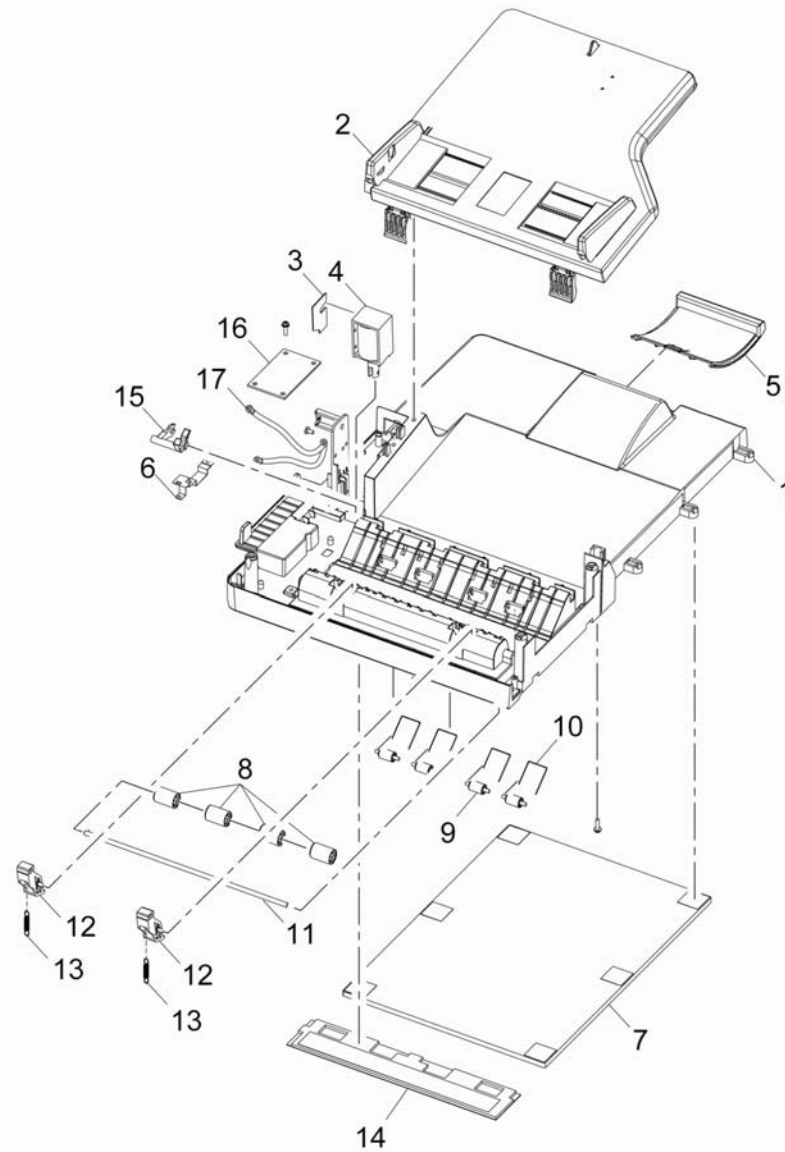

AP-8-1504-A

## PL 5.20 DADF (3 of 7)

Item	Part	Description
1	-	Input tray (P/O PL 5.20 Item 13)
2	-	Document guide (rear) (P/O PL 5.20 Item 13)
3	-	Document guide (front) (P/O PL 5.20 Item 13)
4	-	Document guide rack (P/O PL 5.20 Item 13)
5	-	Pinion gear (P/O PL 5.20 Item 13)
6	-	Guide rack cover (P/O PL 5.20 Item 13)
7	-	Document guide (P/O PL 5.20 Item 13)
8	-	Document guide wire (P/O PL 5.20 Item 13)
9	-	DADF paper length sensor actuator (P/O PL 5.20 Item 13)
10	-	DADF paper length sensor spring (P/O PL 5.20 Item 13)
11	130N01274	DADF paper length sensor (Q05-120) (REP 5.6)
12	-	Sensor assembly cover (P/O PL 5.20 Item 13)
13	002N02741	Input tray assembly (Complete)

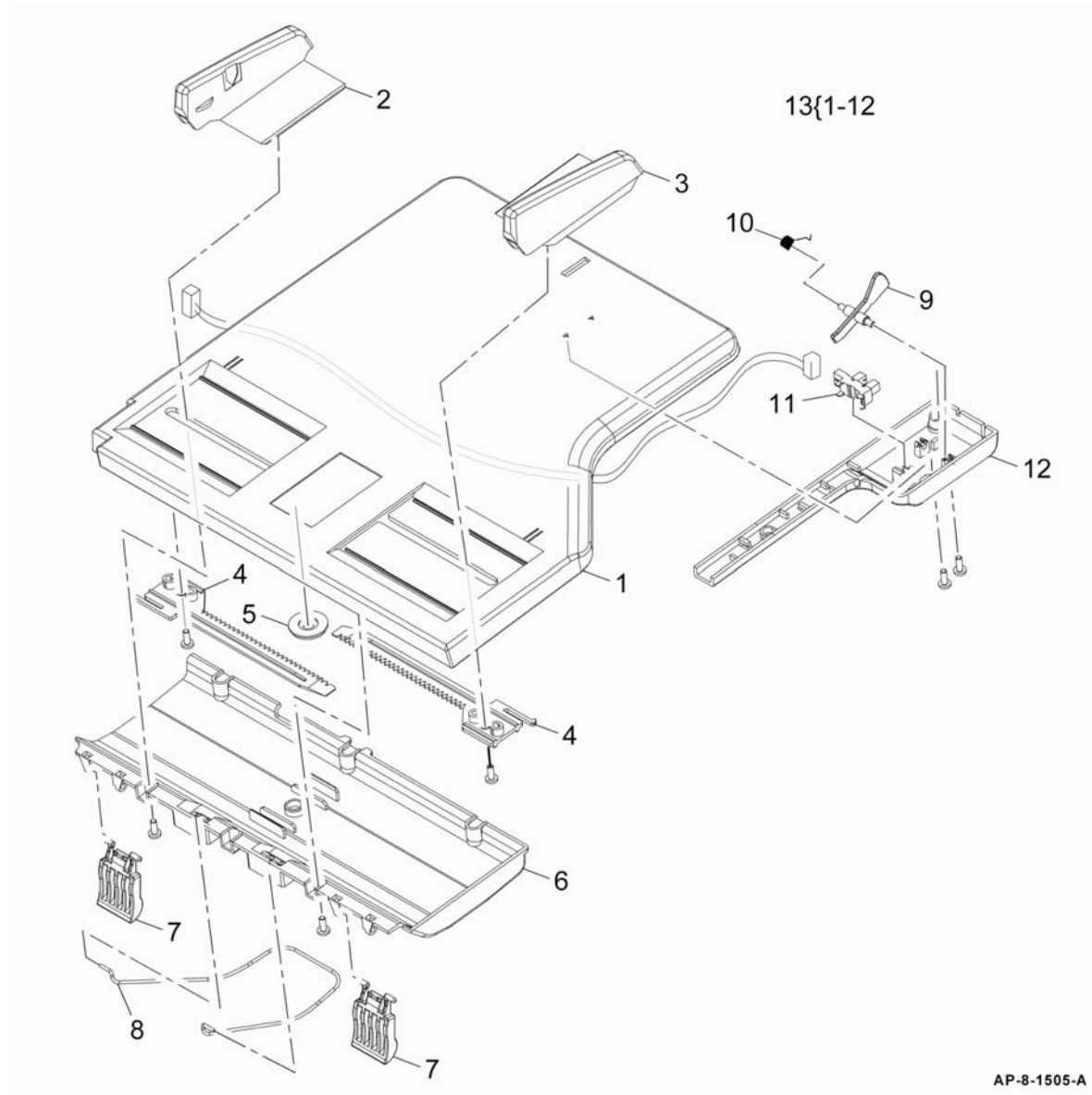

## PL 5.25 DADF (4 of 7)

Item	Part	Description
1	–	DADF door assembly (Complete) (P/O PL 5.10 Item 1)
2	130N01533	Pickup roll assembly (REP 5.7)
3	–	Bush (P/O PL 5.10 Item 1)
4	–	Document gate (P/O PL 5.10 Item 1)
5	–	DADF door (P/O PL 5.10 Item 1)
6	–	Guide fingers (P/O PL 5.10 Item 1)
7	–	Pickup spring (P/O PL 5.10 Item 1)
8	–	Pickup damper (P/O PL 5.10 Item 1)

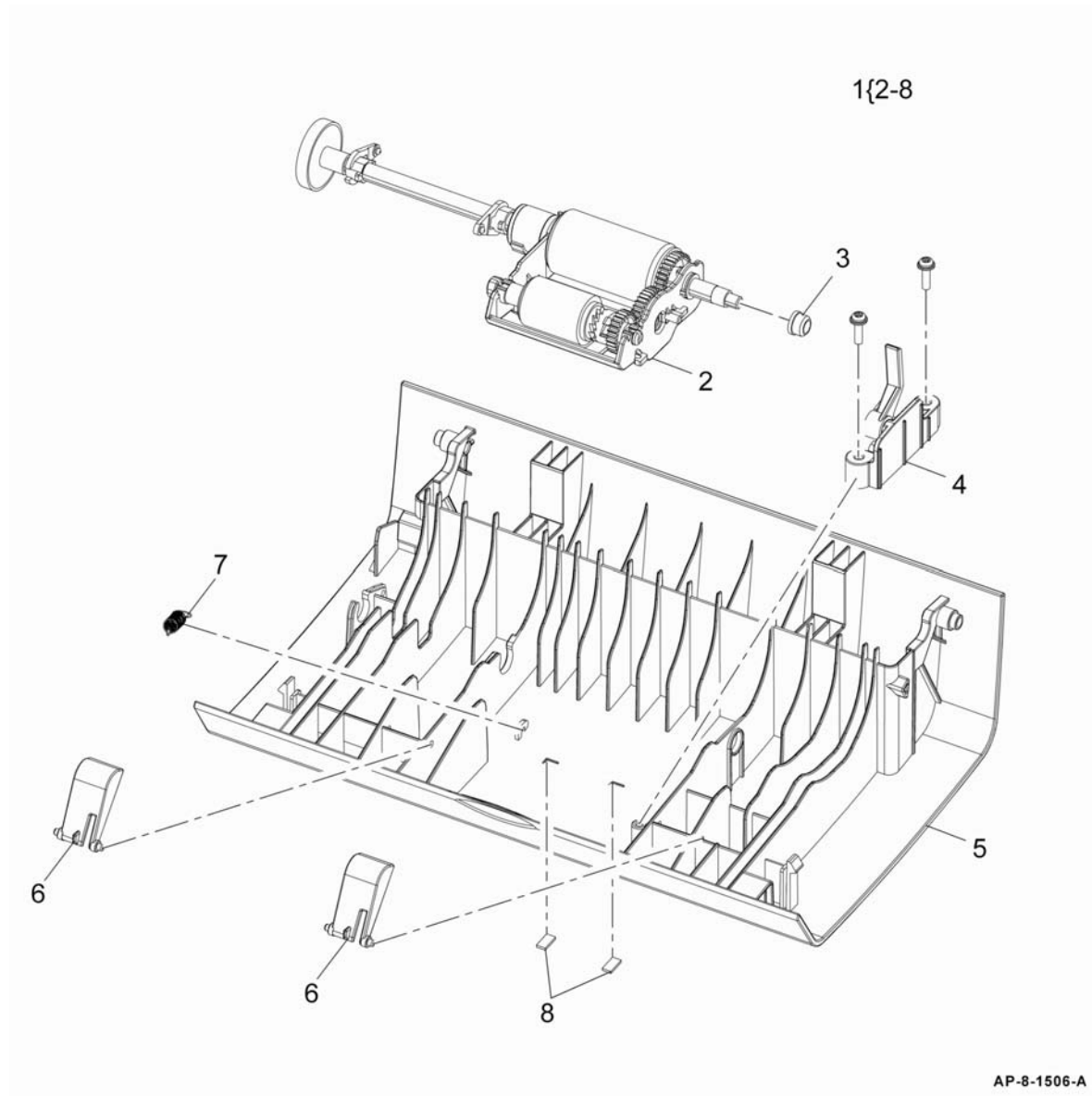

## PL 5.30 DADF (5 of 7)

Item	Part	Description
1	022N02359	Feed assembly (Complete) (REP 5.4)
2	003N01030	Retard pad assembly
3	-	Retard pad spring (P/O PL 5.30 Item 1)
4	-	Feed roll idler (P/O PL 5.30 Item 1)
5	-	Upper cover (P/O PL 5.30 Item 1)
6	-	Mylar (P/O PL 5.30 Item 1)
7	-	Exit idler spring (P/O PL 5.30 Item 1)
8	-	Exit idler (P/O PL 5.30 Item 1)
9	-	Exit idler shaft (P/O PL 5.30 Item 1)
10	-	Exit idler lifting bracket (P/O PL 5.30 Item 1)
11	-	Upper damper (P/O PL 5.30 Item 1)
12	-	Static eliminator (P/O PL 5.30 Item 1)
13	-	Lower cover (P/O PL 5.30 Item 1)
14	-	Ground strip (P/O PL 5.30 Item 1)
15	-	Ground strip (P/O PL 5.30 Item 1)
16	-	Document detect sensor harness (P/O PL 5.30 Item 1)
17	130N01274	Document detect sensor (Q05-100)
18	-	Document detect sensor actuator (P/O PL 5.30 Item 1)
19	-	Document detect sensor actuator spring (P/O PL 5.30 Item 1)

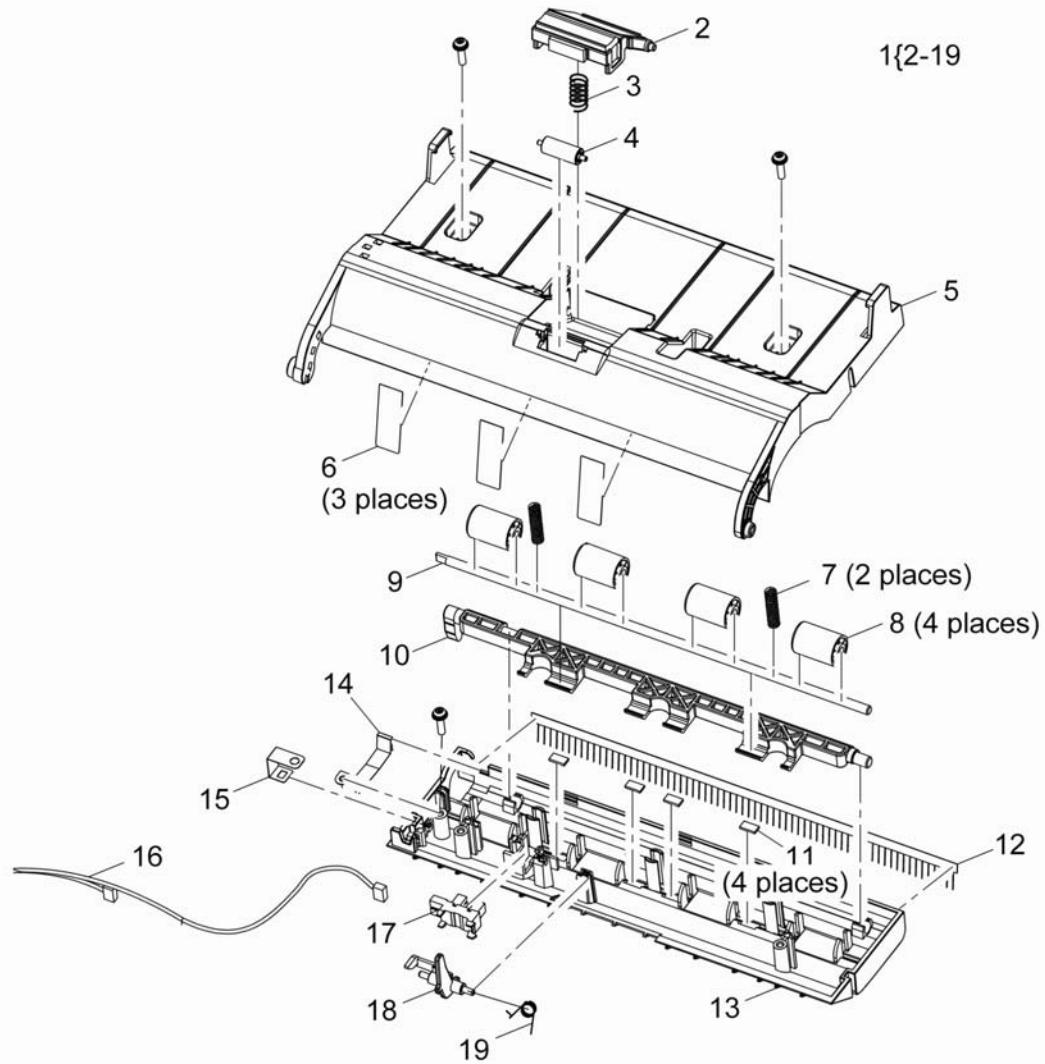

AP-8-1507-A

## PL 5.35 DADF (6 of 7)

Item	Part	Description
1	-	Transport assembly frame (P/O PL 5.35 Item 14)
2	-	White bar plate (P/O PL 5.35 Item 14)
3	-	White bar plate spring (P/O PL 5.35 Item 14)
4	-	Bearing (P/O PL 5.35 Item 14)
5	-	Ground strip (P/O PL 5.35 Item 14)
6	-	Scan sensor actuator (P/O PL 5.35 Item 14)
7	130N01274	Registration sensor (Q05-130) (REP 5.3), Scan sensor (Q05-140) (REP 5.3)
8	-	Exit roll (P/O PL 5.35 Item 14)
9	-	Registration roll (P/O PL 5.35 Item 14)
10	-	Registration sensor actuator (P/O PL 5.35 Item 14)
11	-	Registration sensor actuator spring (P/O PL 5.35 Item 14)
12	-	Scan roll (P/O PL 5.35 Item 14)
13	-	Upper cover (P/O PL 5.35 Item 14)
14	022N02360	Transport assembly (Complete) (REP 5.4)

14{1-13

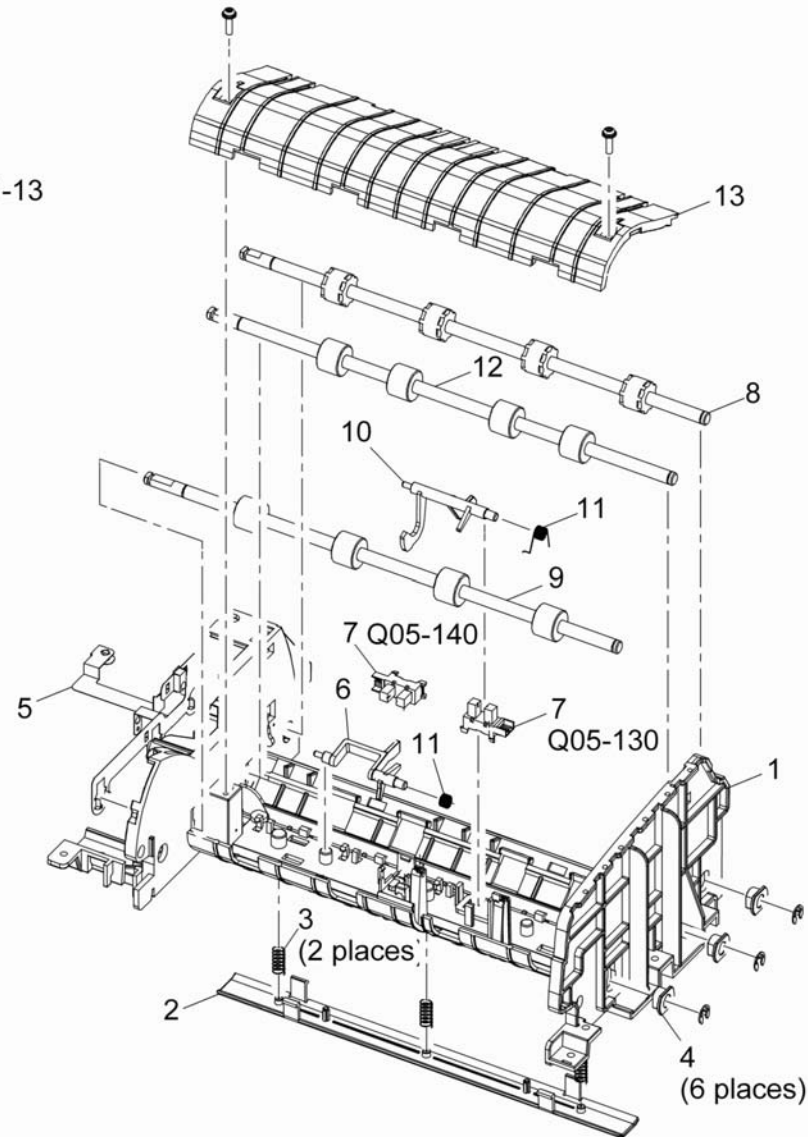

AP-8-1508-A

## PL 5.40 DADF (7 of 7)

Item	Part	Description
1	007N01595	Drive assembly (Complete) (REP 5.5)
2	127N07562	Scan motor (MOT05-200) (REP 5.5)
3	121N01161	Registration solenoid (SOL05-310) (REP 5.5), Pickup solenoid (SOL05-300) (REP 5.5)
4	-	Pickup idler gear (P/O PL 5.40 Item 1)
5	-	Swing bracket (P/O PL 5.40 Item 1)
6	-	Swing bracket feed gear idler (P/O PL 5.40 Item 1)
7	-	Swing bracket pickup gear idler (P/O PL 5.40 Item 1)
8	-	Feed gear idler (P/O PL 5.40 Item 1)
9	-	Lower pickup gear idler (P/O PL 5.40 Item 1)
10	-	Pickup collar (P/O PL 5.40 Item 1)
11	-	Spring (P/O PL 5.40 Item 1)
12	-	Upper pickup gear idler (P/O PL 5.40 Item 1)
13	-	DADF door open sensor (Q05-160) (P/O PL 5.40 Item 1) (REP 5.1)
14	-	Motor harness (P/O PL 5.40 Item 1)
15	-	Drive bracket (P/O PL 5.40 Item 1)

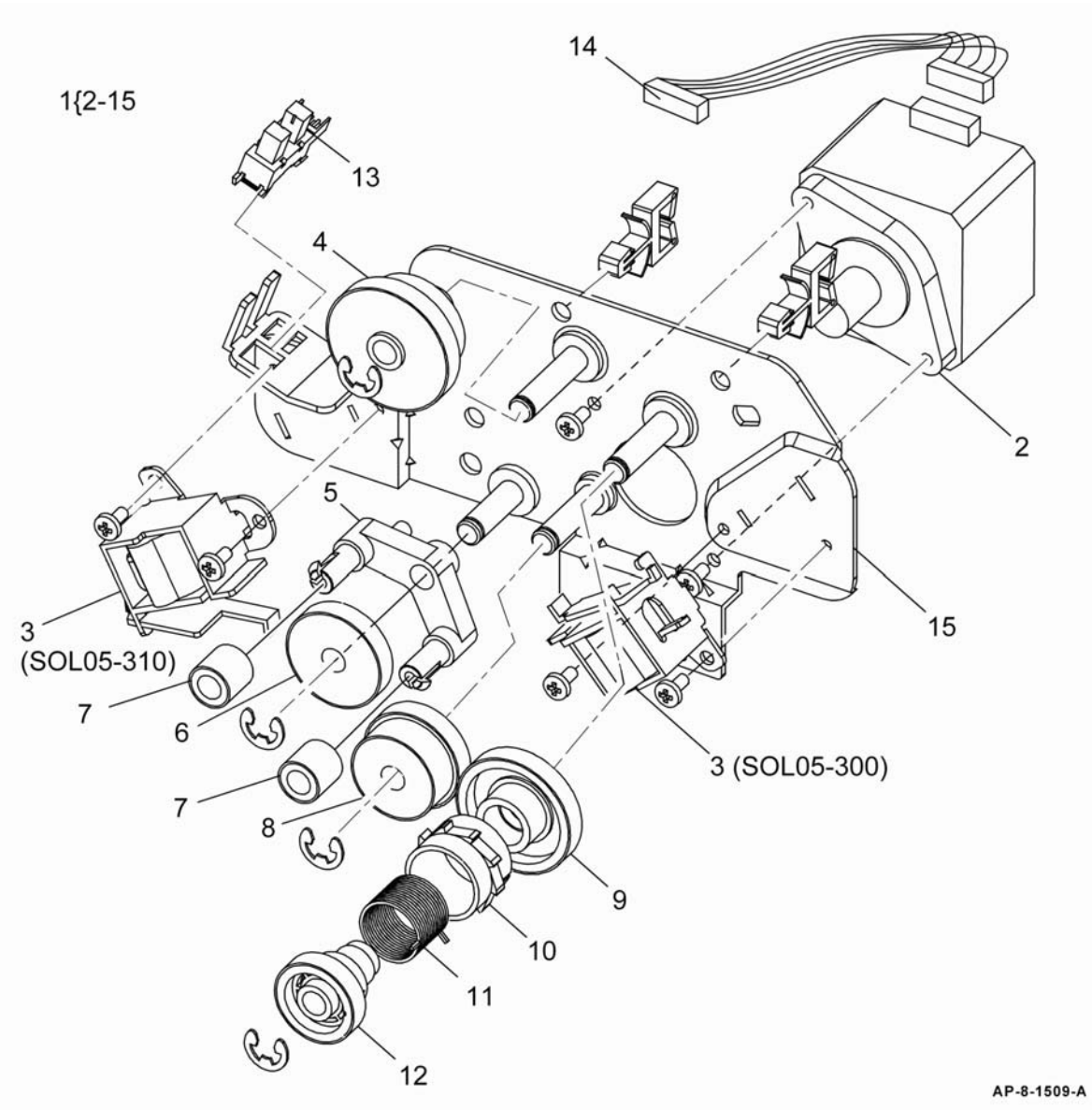

# PL 6.10 LSU

Item	Part	Description
1	122N00259	LSU (REP 6.1)
2	152N11753	LSU interlock switch (REP 6.2)

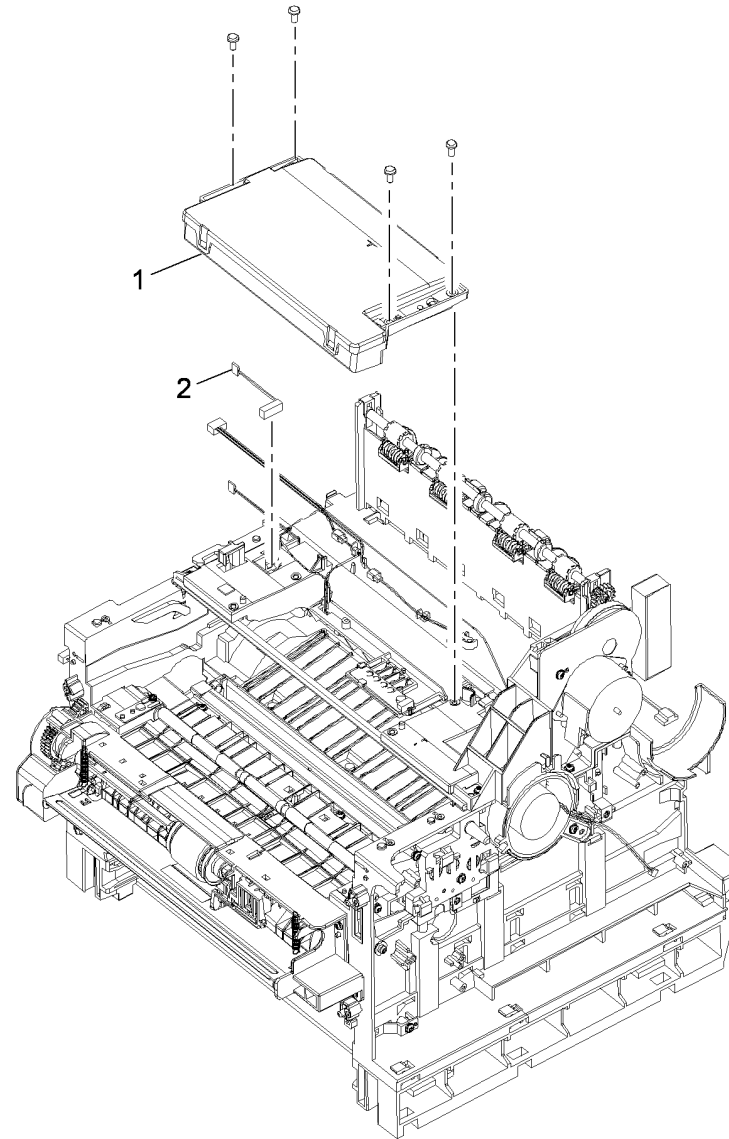

AP-8-1535-A

## PL 7.10 Bypass Feed Assembly (1 of 2)

Item	Part	Description
1	130N01274	Bypass paper empty sensor (Q07-510) (REP 7.5)
2	-	Clutch spring (P/O PL 7.10 Item 29)
3	-	Baffle lift spring (P/O PL 7.10 Item 29) (MEXICO)
4	-	Bypass feed solenoid (SOL08-500) (P/O PL 7.10 Item 29)
5	-	Bypass paper empty sensor harness (P/O PL 7.10 Item 29) (REP 7.1)
6	-	Bush (P/O PL 7.10 Item 29)
7	-	Locking collar (P/O PL 7.10 Item 29)
8	-	Retard pad holder (P/O PL 7.10 Item 29)
9	-	Sensor bracket (P/O PL 7.10 Item 29)
10	-	Baffle (P/O PL 7.10 Item 29)
11	-	Pickup bracket (P/O PL 7.10 Item 29)
12	-	Frame (P/O PL 7.10 Item 29)
13	-	Spring (P/O PL 7.10 Item 29)
14	-	Guide mylar (P/O PL 7.10 Item 29)
15	-	Idler gear (P/O PL 7.10 Item 29)
16	-	Pickup shaft (P/O PL 7.10 Item 29)
17	-	Clutch (rear) (P/O PL 7.10 Item 29)
18	-	Clutch (front) (P/O PL 7.10 Item 29)
19	-	Pickup cam (P/O PL 7.10 Item 29)
20	-	Cam roll (P/O PL 7.10 Item 29)
21	-	Pickup idler (P/O PL 7.10 Item 29)
22	-	Bypass paper empty sensor actuator (P/O PL 7.10 Item 29)
23	-	Lower retard pad (P/O PL 7.10 Item 29)
24	-	Pickup rubber outer shaft (P/O PL 7.10 Item 29)
25	-	Pickup rubber inner shaft (P/O PL 7.10 Item 29)
26	130N01534	Pickup rubber
27	-	Retard pad (P/O PL 7.10 Item 29) (NOTE)
28	-	Bypass pickup roll assembly (P/O PL 7.10 Item 29) (NOTE) (REP 7.3)
29	050N00520	Bypass feed assembly (Complete) (REP 7.1)

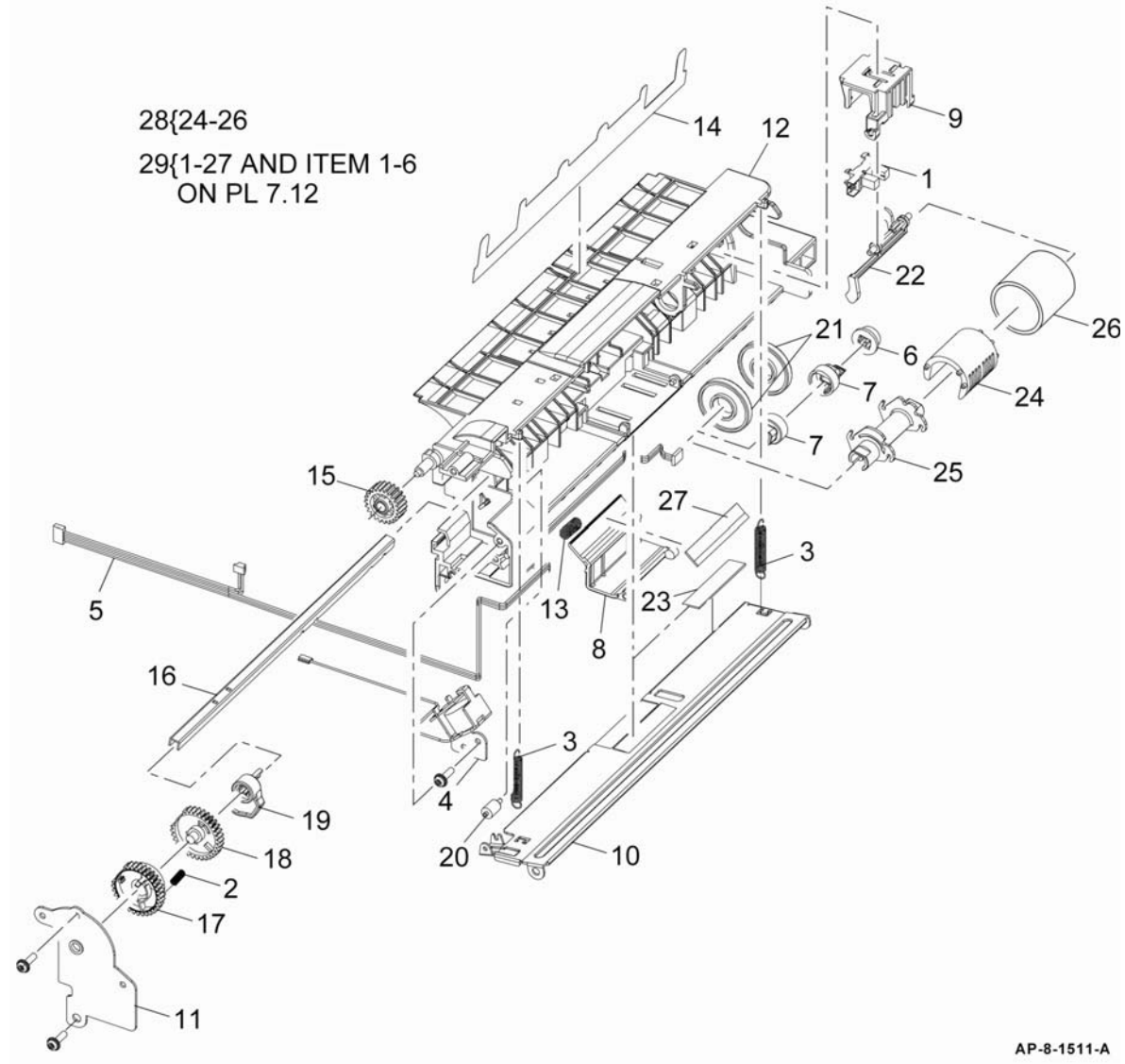

**NOTE:** HFSI. To reset the HSFI count go to GP 16.

## PL 7.12 Bypass Feed Assembly (2 of 2)

Item	Part	Description
1	–	Feed idler holder (P/O PL 7.10 Item 29)
2	–	Lower exit idler spring (P/O PL 7.10 Item 29)
3	–	Feed idler shaft (P/O PL 7.10 Item 29)
4	–	Feed idler shaft holder (P/O PL 7.10 Item 29)
5	–	Feed idler cover (P/O PL 7.10 Item 29)
6	–	Feed roll idler (P/O PL 7.10 Item 29)
7	–	Bypass feed assembly (REF: PL 7.10 Item 29)

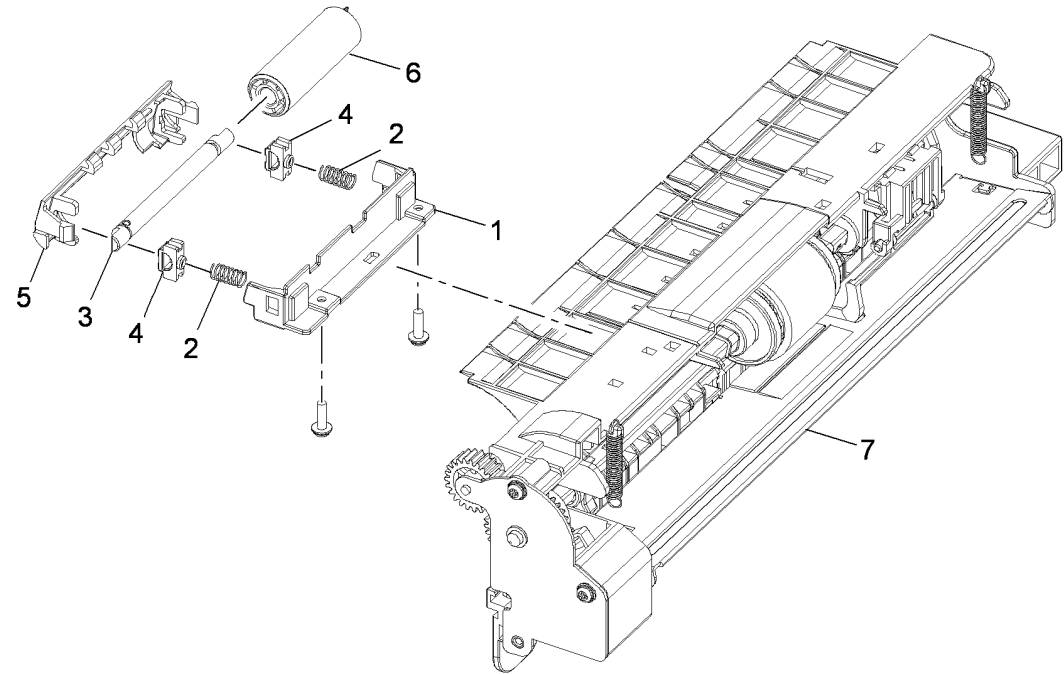

AP-8-1528-A

## PL 7.15 Front Cover Assembly

Item	Part	Description
1	-	Front cover (P/O PL 7.15 Item 15)
2	-	Lower bypass tray cover (P/O PL 7.15 Item 15)
3	-	Front document guide (P/O PL 7.15 Item 15)
4	-	Rear document guide (P/O PL 7.15 Item 15)
5	-	Release latch (P/O PL 7.15 Item 15)
6	-	Link arm (P/O PL 7.15 Item 15)
7	-	Upper bypass tray cover (P/O PL 7.15 Item 15)
8	-	Tray extension (P/O PL 7.15 Item 15)
9	-	Front catch (P/O PL 7.15 Item 15)
10	-	Rear catch (P/O PL 7.15 Item 15)
11	-	Pinion gear (P/O PL 7.15 Item 15)
12	-	Front catch spring (P/O PL 7.15 Item 15)
13	-	Rear catch spring (P/O PL 7.15 Item 15)
14	-	Bypass tray (P/O PL 7.15 Item 15)
15	002N02718	Front cover assembly (Complete)

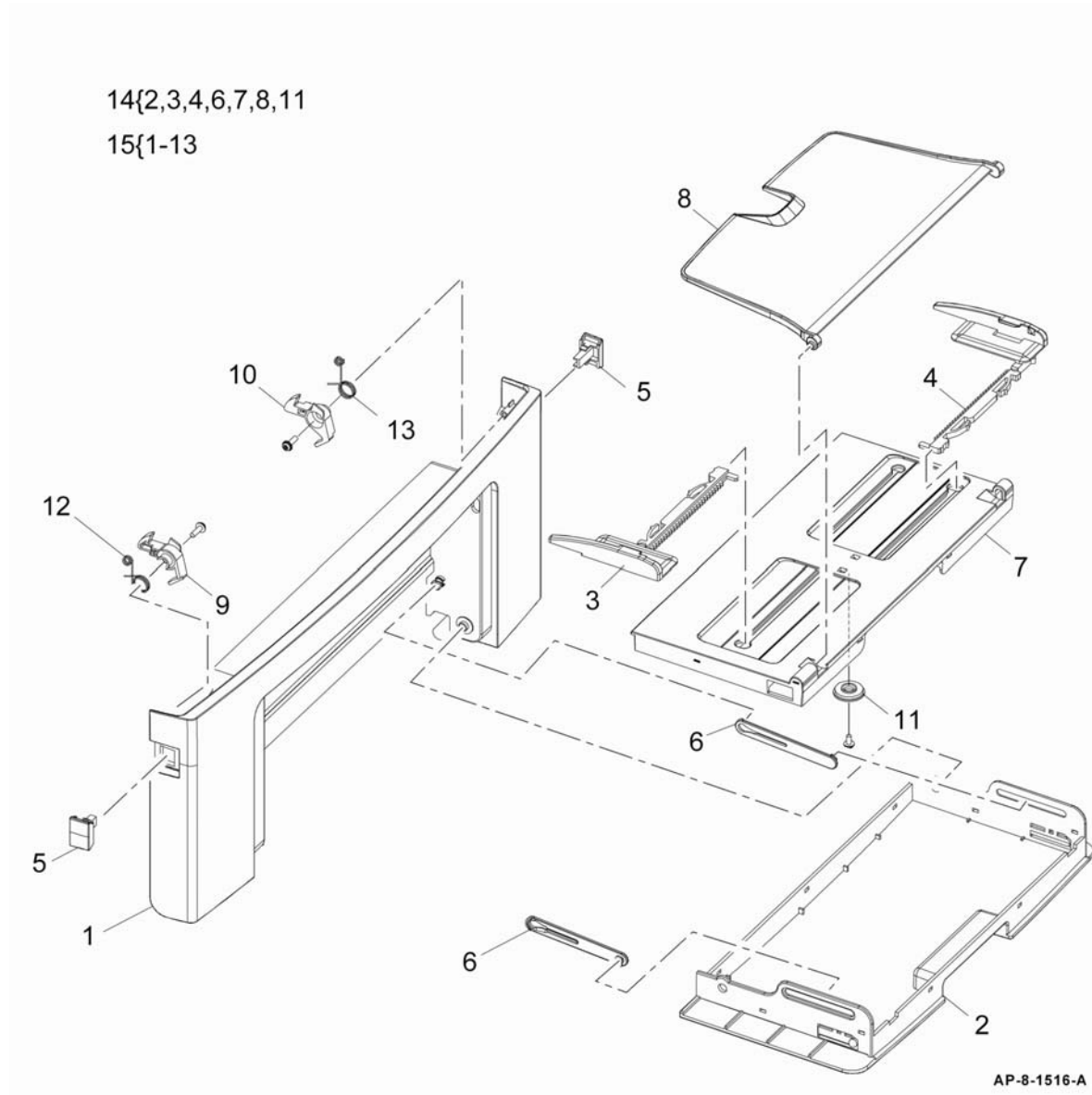

# PL 8.10 Paper Tray

Item	Part	Description
1	050N00518	Paper tray (Complete)
2	-	Tray empty indicator (P/O PL 8.10 Item 1)
3	-	Right width paper guide (P/O PL 8.10 Item 1)
4	-	Right width paper guide lock assembly (P/O PL 8.10 Item 1)
5	-	Right tray down lever (P/O PL 8.10 Item 1)
6	-	Tray down lever spring (P/O PL 8.10 Item 1)
7	-	Tray frame (P/O PL 8.10 Item 1)
8	-	Paper length guide spring (P/O PL 8.10 Item 1)
9	-	Paper length guide (P/O PL 8.10 Item 1)
10	-	Paper length guide lower lock (P/O PL 8.10 Item 1)
11	-	Paper length guide spring (P/O PL 8.10 Item 1)
12	-	Paper length guide upper lock (P/O PL 8.10 Item 1)
13	-	Tray extension (P/O PL 8.10 Item 1)
14	-	Tray extension bracket (P/O PL 8.10 Item 1)
15	-	Left tray down lever spring (P/O PL 8.10 Item 1)
16	-	Lift plate actuator spring (P/O PL 8.10 Item 1)
17	-	Pinion gear (P/O PL 8.10 Item 1)
18	-	Left width paper guide (P/O PL 8.10 Item 1)
19	-	Lift plate actuator (P/O PL 8.10 Item 1)
20	019N00947	Retard pad assembly
21	-	Retard pad holder spring (P/O PL 8.10 Item 1)
22	-	Retard pad holder housing (P/O PL 8.10 Item 1)
23	-	Ground strip (P/O PL 8.10 Item 1)
24	-	Paper exit frame (P/O PL 8.10 Item 1)
25	055N00297	Lead edge guide
26	009N01604	Lead edge guide spring
27	-	Lift plate spring (P/O PL 8.10 Item 1)
28	-	Lift plate (P/O PL 8.10 Item 1)
29	-	Pad (P/O PL 8.10 Item 1)
30	-	Label (P/O PL 8.10 Item 1)
31	-	Front cover (P/O PL 8.10 Item 1)

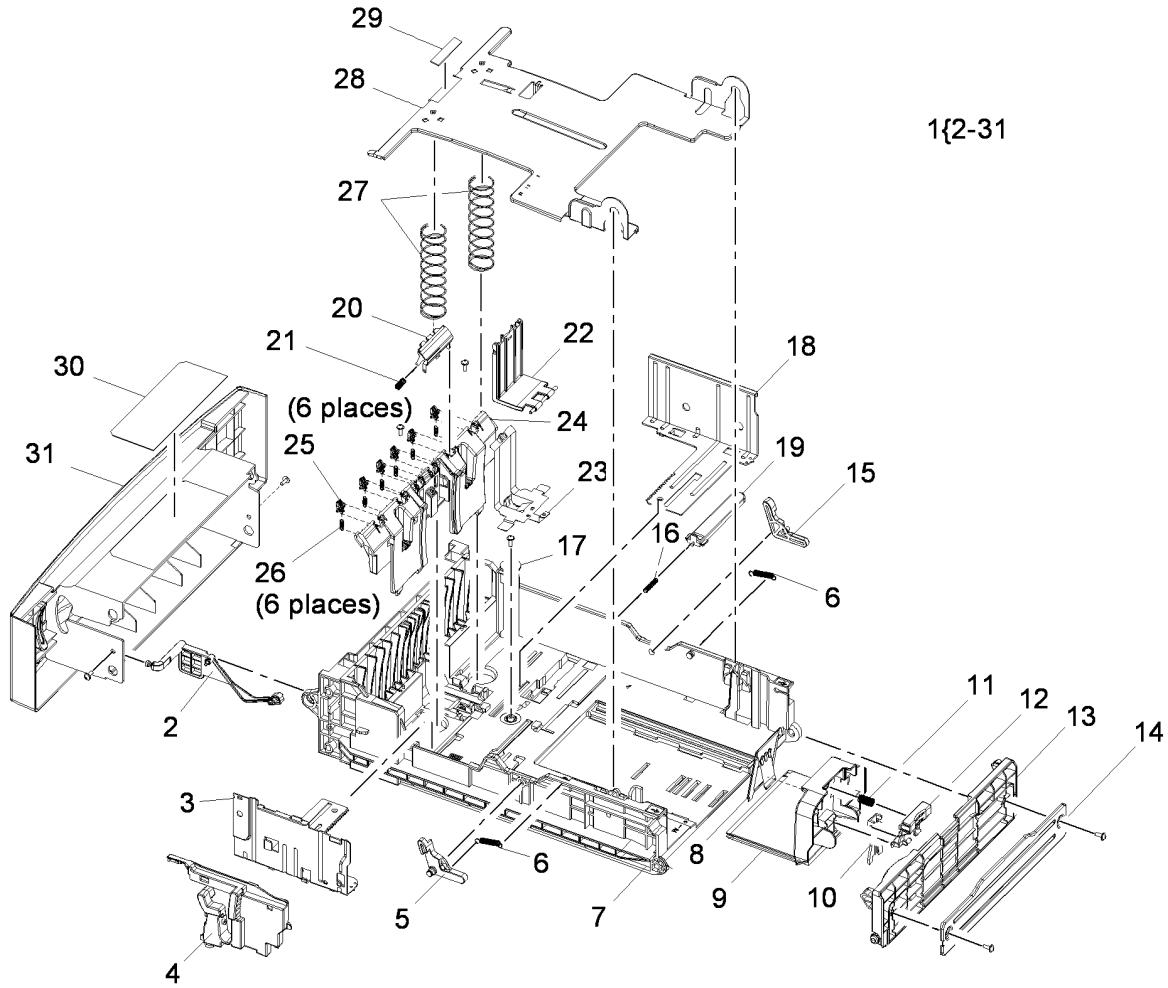

AP-8-1514-A

## PL 8.15 Tray 2 Assembly (1 of 2)

Item	Part	Description
1	-	Front cover (P/O PL 8.15 Item 1)
2	-	Bottom cross bar (P/O PL 8.15 Item 1)
3	-	Feed roll idler (P/O PL 8.15 Item 1)
4	-	Feed roll idler spring (P/O PL 8.15 Item 1)
5	-	Left cover (P/O PL 8.15 Item 1)
6	-	Left lower noise insulation (P/O PL 8.15 Item 1)
7	-	Left cover noise insulation (P/O PL 8.15 Item 1)
8	-	Ground strip (P/O PL 8.15 Item 1)
9	-	Tray 2 connector (P/O PL 8.15 Item 1)
10	-	Tray 2 connector holder (P/O PL 8.15 Item 1)
11	-	Tray 2 paper empty sensor cover (P/O PL 8.15 Item 1)
12	-	Rear noise insulation cover (P/O PL 8.15 Item 1)
13	-	Rear noise insulation (P/O PL 8.15 Item 1)
14	-	Rear cover (P/O PL 8.15 Item 1)
15	-	Catch (P/O PL 8.15 Item 1)
16	-	Right cover (P/O PL 8.15 Item 1)
17	-	Right lower noise insulation (P/O PL 8.15 Item 1)
18	-	Idler gear 1 (P/O PL 8.15 Item 27)
19	-	Idler gear clip (P/O PL 8.15 Item 27)
20	-	Drive assembly bracket (P/O PL 8.15 Item 27)
21	-	Idler gear 2 (P/O PL 8.15 Item 27)
22	-	Idler gear 3 (P/O PL 8.15 Item 27)
23	-	Tray 2 feed motor (MOT07-210) (P/O PL 8.15 Item 27) (REP 7.4)
24	-	Tray 2 feed motor bracket (P/O PL 8.15 Item 27)
25	-	Idler gear 4 (P/O PL 8.15 Item 27)
26	-	Idler gear 5 (P/O PL 8.15 Item 27)
27	127N07563	Tray 2 drive assembly
28	050N00519	Tray 2 assembly (Complete)

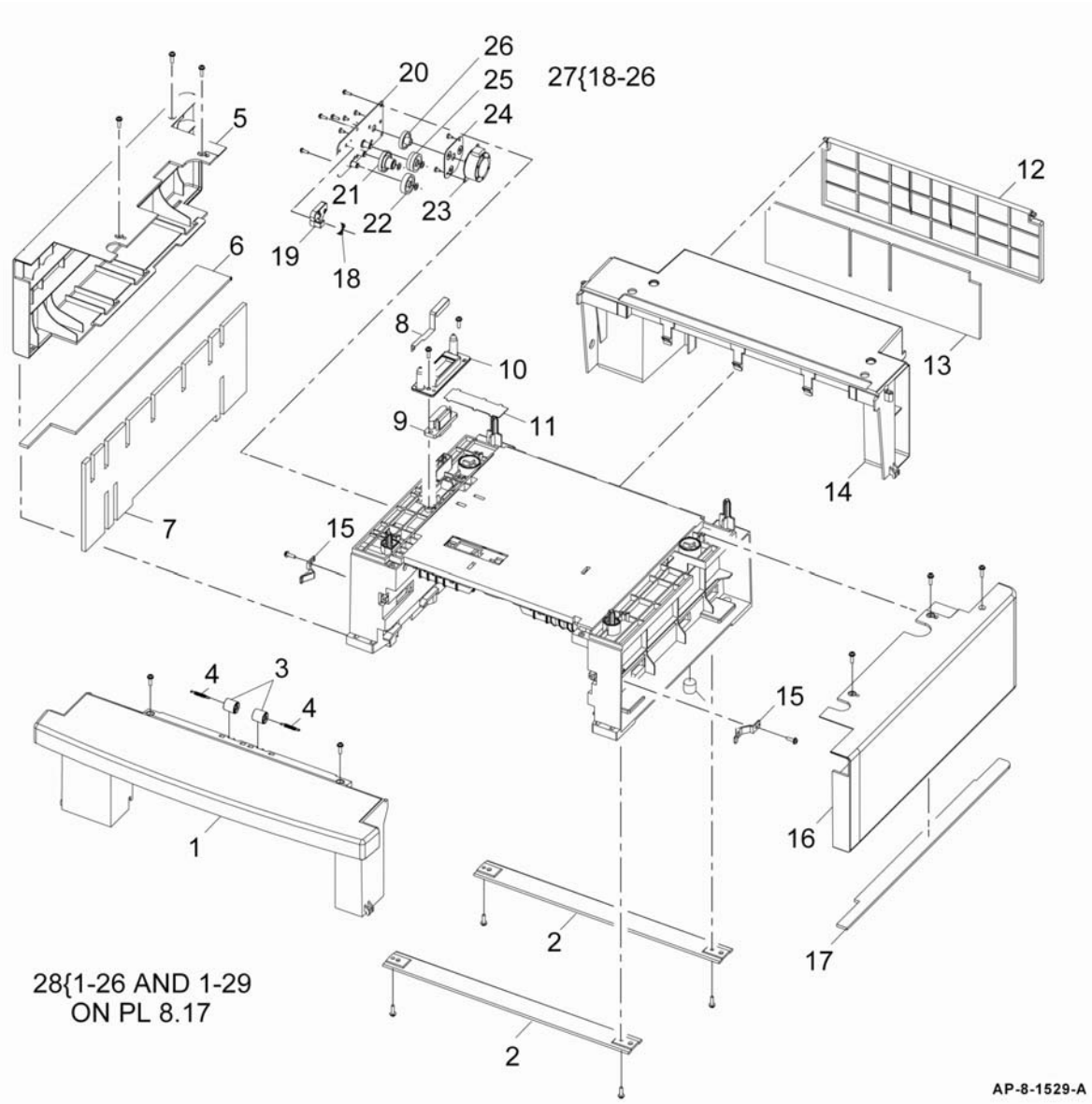

## PL 8.17 Tray 2 Assembly (2 of 2)

Item	Part	Description
1	130N01274	Tray 2 paper empty sensor (Q07-210)
2	-	Tray 2 paper empty sensor actuator (P/O PL 8.15 Item 28)
3	-	Static eliminator fixing (P/O PL 8.15 Item 28)
4	-	Left underside cover (P/O PL 8.15 Item 28)
5	-	Right underside cover (P/O PL 8.15 Item 28)
6	-	Pickup idler (P/O PL 8.17 Item 31)
7	-	Pickup rubber (P/O PL 8.17 Item 31)
8	-	Pickup roll shaft (P/O PL 8.15 Item 28)
9	-	Static eliminator (P/O PL 8.15 Item 28)
10	-	Pickup roll (P/O PL 8.17 Item 31)
11	-	Feed roll holder (P/O PL 8.15 Item 28)
12	-	Feed roll (P/O PL 8.15 Item 28)
13	-	KL-clip (P/O PL 8.15 Item 28)
14	-	Bearing (P/O PL 8.15 Item 28)
15	-	Pickup roll cam (P/O PL 8.15 Item 28)
16	-	Ground strip (P/O PL 8.15 Item 28)
17	-	Feed shaft (P/O PL 8.15 Item 28)
18	-	Feed gear (P/O PL 8.15 Item 28)
19	-	Snap on washer (P/O PL 8.15 Item 28)
20	-	Outer pickup gear spring (P/O PL 8.17 Item 30)
21	-	Pickup cam spring (P/O PL 8.15 Item 28)
22	-	Outer pickup gear (P/O PL 8.17 Item 30)
23	-	Inner pickup gear (P/O PL 8.17 Item 30)
24	121N01164	Tray 2 pickup solenoid (SOL08-820) (REP 7.4)
25	140N63300	Tray 2 PWB
26	-	PWB cover (P/O PL 8.15 Item 28)
27	-	Pickup cam (P/O PL 8.15 Item 28)
28	-	Pick up gear core (P/O PL 8.15 Item 28)
29	152N11752	Tray 2 harness
30	007N01593	Clutch assembly
31	022N02345	Pickup roll assembly (NOTE)

30{20,22,23

31{6,7,10

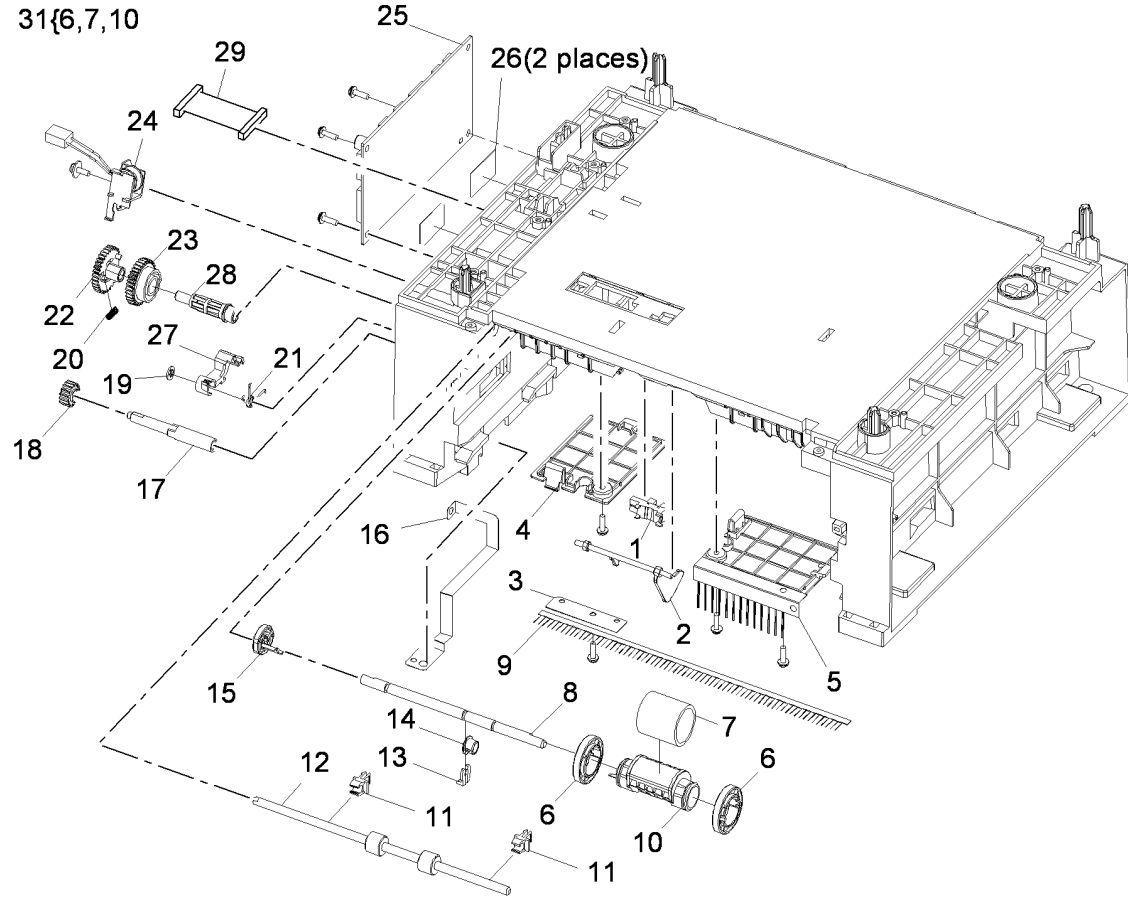

AP-8-1515-A

**NOTE:** HFSI. To reset the HFSI count go to GP 16.

## PL 8.20 Rear Cover Assembly

Item	Part	Description
1	-	Magnet (P/O PL 8.20 Item 11)
2	-	Rear cover (P/O PL 8.20 Item 11)
3	-	Sub panel cover (P/O PL 8.20 Item 11)
4	-	Magnet catch (P/O PL 8.20 Item 11)
5	-	Face up cover (P/O PL 8.20 Item 11)
6	-	Label (P/O PL 8.20 Item 11)
7	-	Fuser output guide (P/O PL 8.20 Item 11)
8	-	Rear stacker (P/O PL 8.20 Item 11)
9	-	Duplex gate (P/O PL 8.20 Item 11)
10	-	Idler (P/O PL 8.20 Item 11)
11	002N02716	Rear cover assembly (Complete)

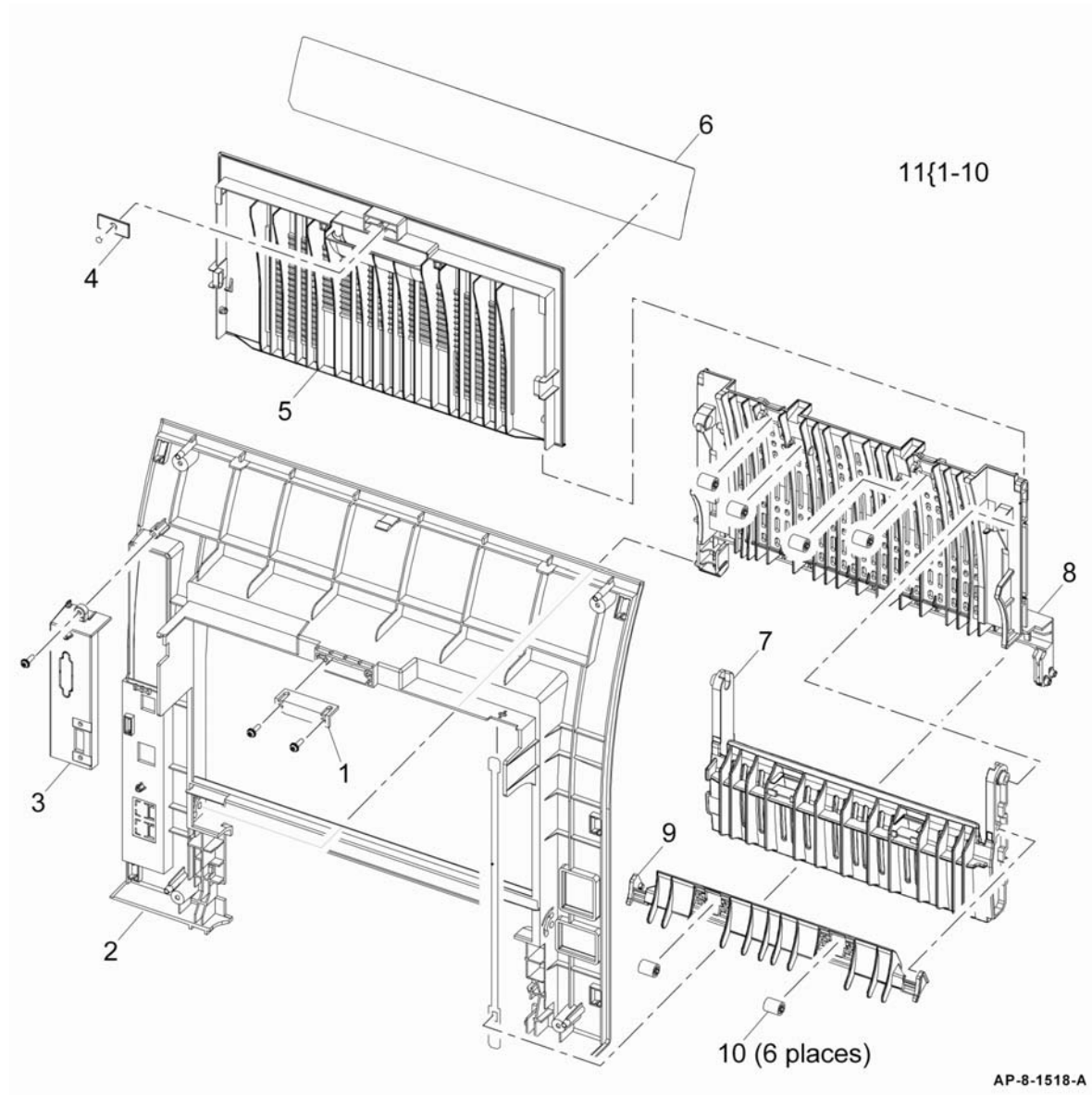

## PL 8.25 Registration Rolls

Item	Part	Description
1	-	Grounding plate (Not Spared)
2	-	Grounding plate block (Not Spared)
3	-	Registration roll (Not Spared)
4	-	Feed roll holder (Not Spared)
5	-	Rear feed roll holder (Not Spared)
6	-	Front feed roll holder (Not Spared)
7	-	Feed roll spring (Not Spared)
8	-	Idler roll securing bracket (Not Spared)
9	-	Release latch (Not Spared)
10	-	Ground strip (Not Spared)
11	-	Feed sensor actuator (Not Spared)
12	-	Feed sensor actuator housing (Not Spared)
13	-	Duplex jam 1 sensor actuator (Not Spared)
14	-	Registration sensor actuator (Not Spared)
15	-	Actuator spring (Not Spared)
16	-	Actuator housing (Not Spared)
17	-	Registration roll idler (Not Spared)
18	121N01162	Registration solenoid (SOL08-850) (REP 7.2)
19	121N01163	Tray 1 pickup solenoid (SOL08-810) (REP 7.2)
20	-	Feed bracket (Not Spared)
21	005N01031	Registration roll clutch (REP 8.1)
22	-	Tray 2 connector (Not Spared)
23	-	Thermistor 2 (Not Spared) (NOTE)

**NOTE:** Shown for reference only. For future use.

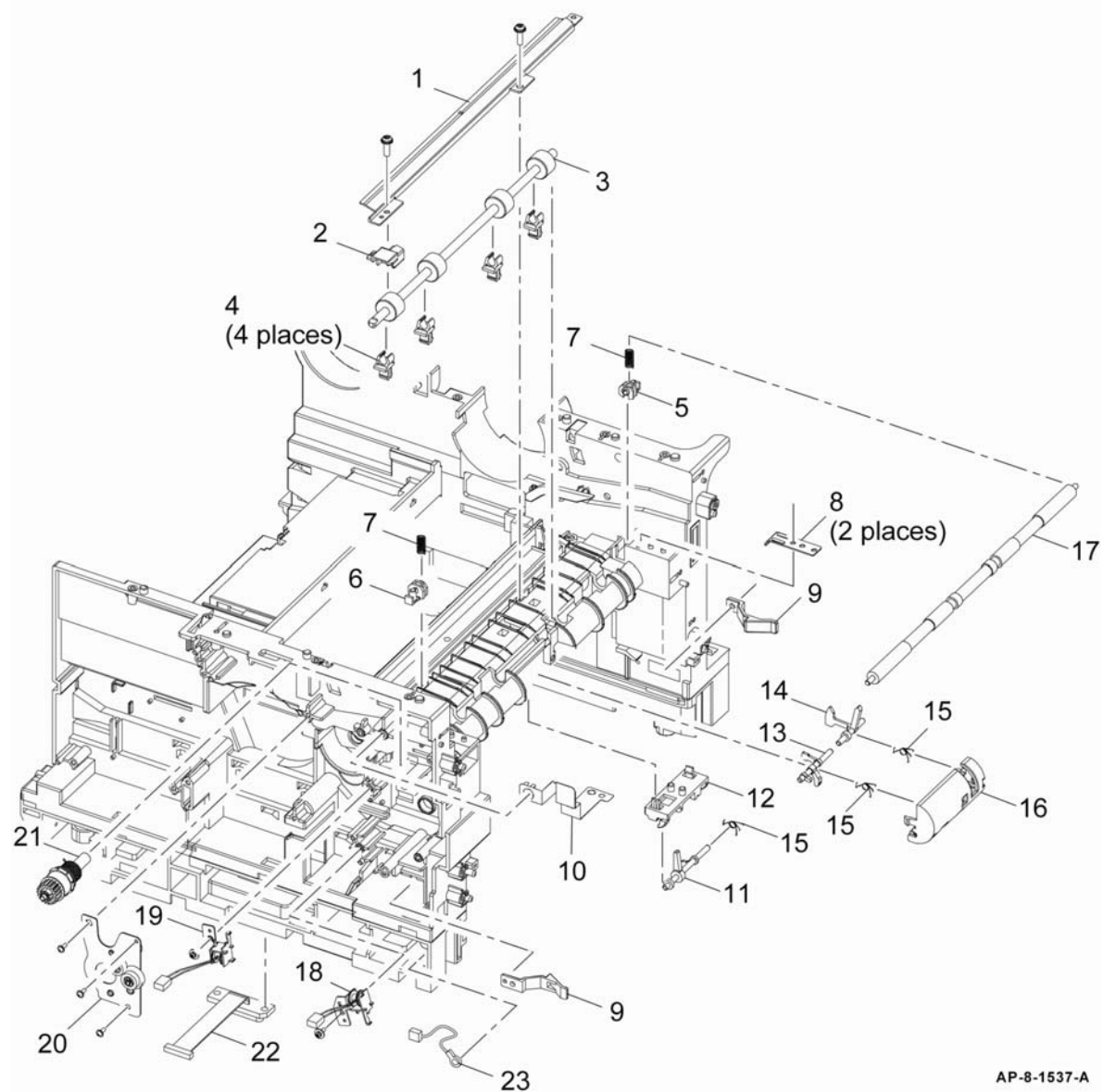

AP-8-1537-A

## PL 9.10 Print Cartridge

Item	Part	Description
1	–	Print cartridge (Not Spared) (NOTE)
2	002N02628	Transfer roll (NOTE)
3	–	Spring contacts (Not Spared)
4	–	Print cartridge power strip (Supply, DEV, OPC) (Not Spared)
5	–	Print cartridge power strip (MHV) (Not Spared)
6	–	Terminal cover (Not Spared) (REP 9.1)
7	140N63302	CRUM PWB

**NOTE:** HFSI. To reset the HSF1 count go to GP 16.

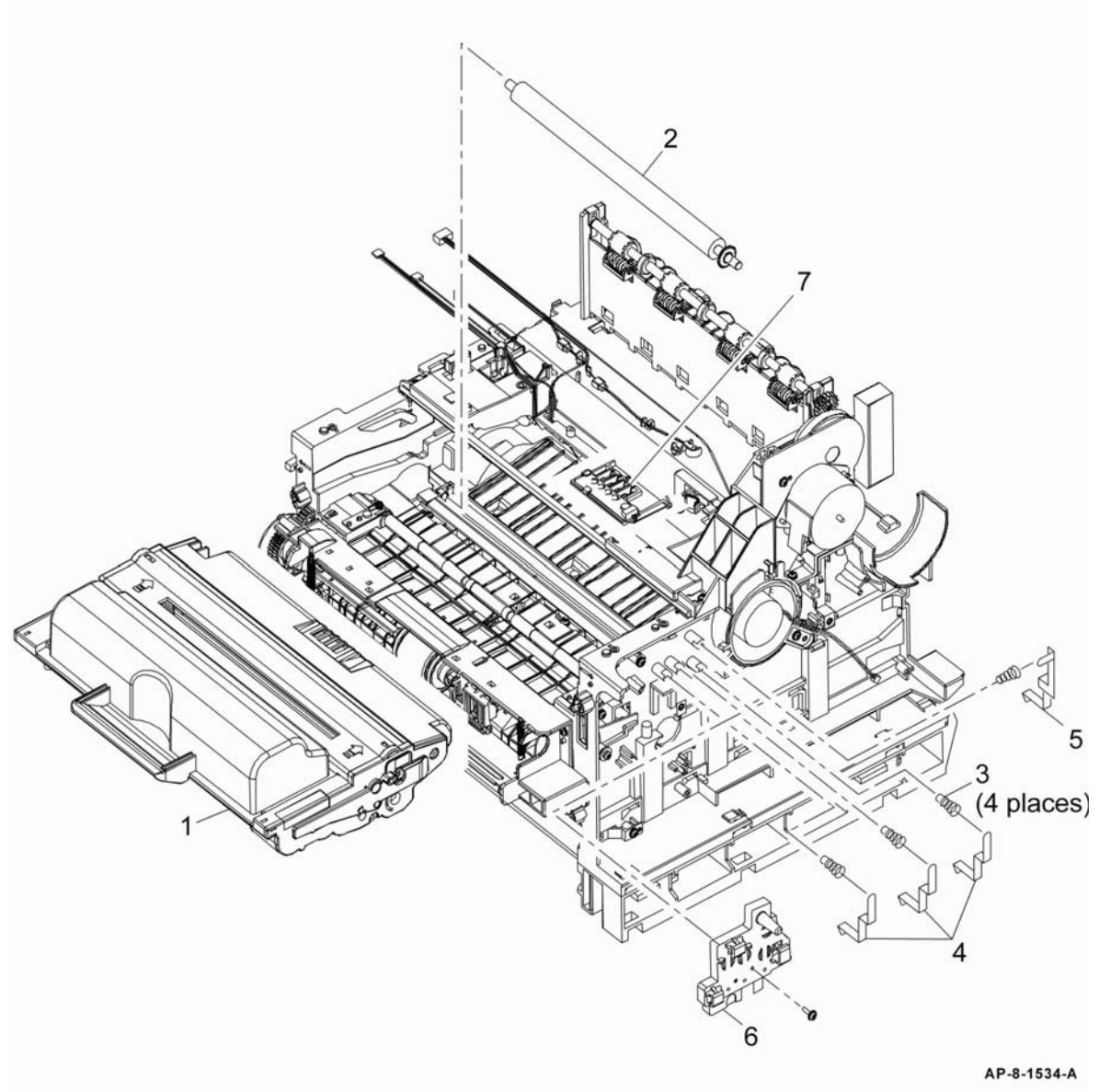

## PL 10.10 Fuser Assembly (1 of 3)

Item	Part	Description
1	126N00290	Fuser assembly (220V) (REF: PL 10.12, PL 10.15) (NOTE)
-	126N00291	Fuser assembly (110V) (REF: PL 10.12, PL 10.15) (NOTE)

**NOTE:** HFSI. To reset the HSF1 count go to GP 16.

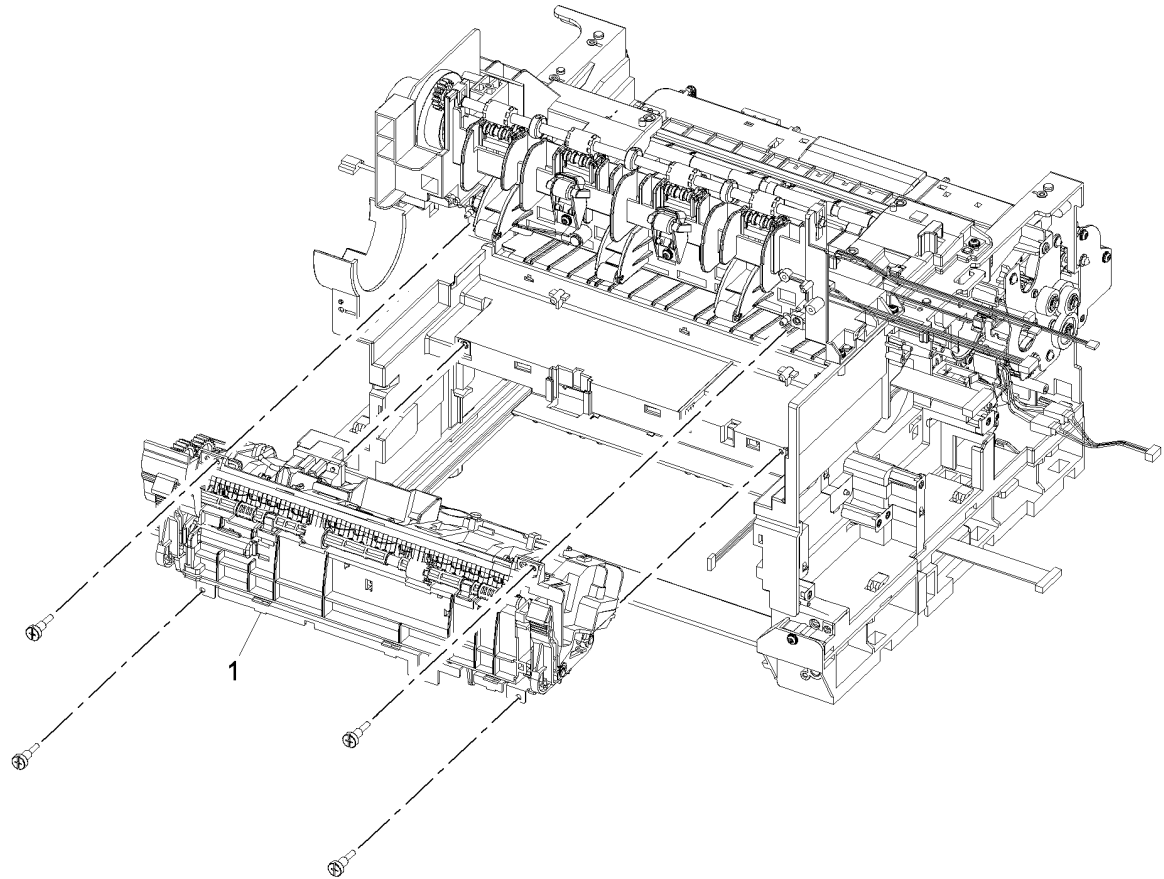

AP-8-1536-A

## PL 10.12 Fuser Assembly (2 of 3)

Item	Part	Description
1	-	Upper cover (P/O PL 10.10 Item 1)
2	-	Left lamp cap (P/O PL 10.10 Item 1)
3	-	Right lamp cap (P/O PL 10.10 Item 1)
4	-	Stripper finger spring (P/O PL 10.10 Item 1)
5	-	Static eliminator (P/O PL 10.10 Item 1)
6	-	Fuser exit roll (P/O PL 10.10 Item 1)
7	-	Exit gear (P/O PL 10.10 Item 1)
8	-	Exit roll holder (P/O PL 10.12 Item 19)
9	-	Fuser exit sensor actuator (P/O PL 10.12 Item 19)
10	-	Release latch (P/O PL 10.12 Item 19)
11	-	Release latch spring (P/O PL 10.12 Item 19)
12	-	Fuser door (P/O PL 10.12 Item 19)
13	-	Stripper finger (P/O PL 10.10 Item 1)
14	-	Ground strip (P/O PL 10.10 Item 1)
15	-	Fuser connector (P/O PL 10.10 Item 1)
16	130N01489	Thermistor
17	-	Idler (P/O PL 10.10 Item 1)
18	130N01490	Thermostat
19	126N00292	Fuser door (Complete)

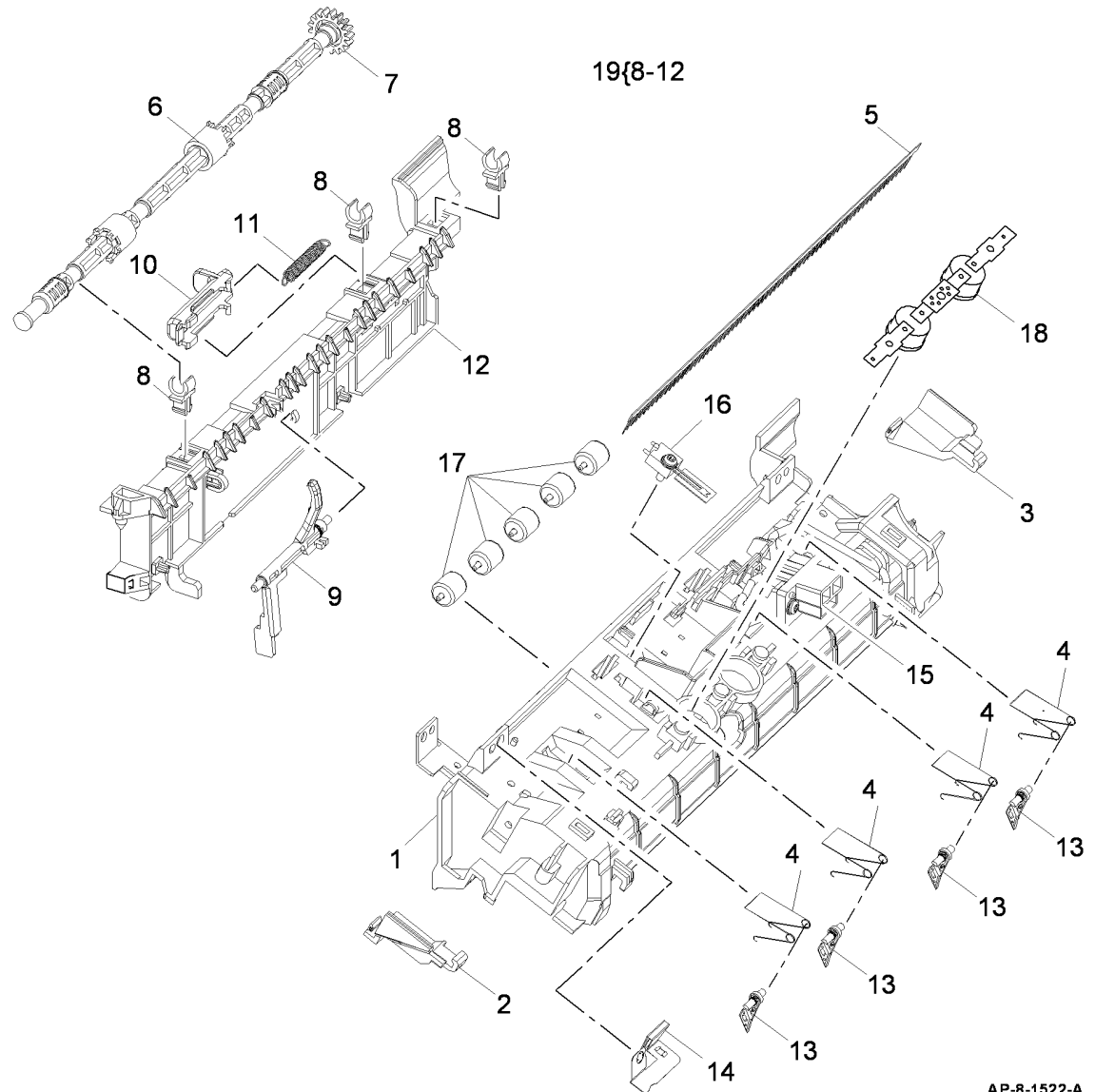

AP-8-1522-A

## PL 10.15 Fuser Assembly (3 of 3)

Item	Part	Description
1	-	Heat roll (P/O PL 10.10 Item 1)
2	-	Pressure roll 1 (P/O PL 10.10 Item 1)
3	-	Pressure roll 2 (P/O PL 10.10 Item 1)
4	-	Fuser idler gear (P/O PL 10.10 Item 1)
5	-	Link jam lever (P/O PL 10.10 Item 1)
6	-	Input guide (P/O PL 10.10 Item 1)
7	-	Pressure roll securing block (P/O PL 10.10 Item 1)
8	-	Outer bearing (P/O PL 10.10 Item 1)
9	-	Inner bearing (P/O PL 10.10 Item 1)
10	-	Pressure roll gear bracket (P/O PL 10.10 Item 1)
11	-	Fuser frame (P/O PL 10.10 Item 1)
12	122N00260	Heat lamp (110V) (REP 10.6)
-	122N00261	Heat lamp (220V) (REP 10.6)
13	-	Fuser gear (P/O PL 10.10 Item 1)
14	-	Fuser nip release handle (P/O PL 10.10 Item 1)

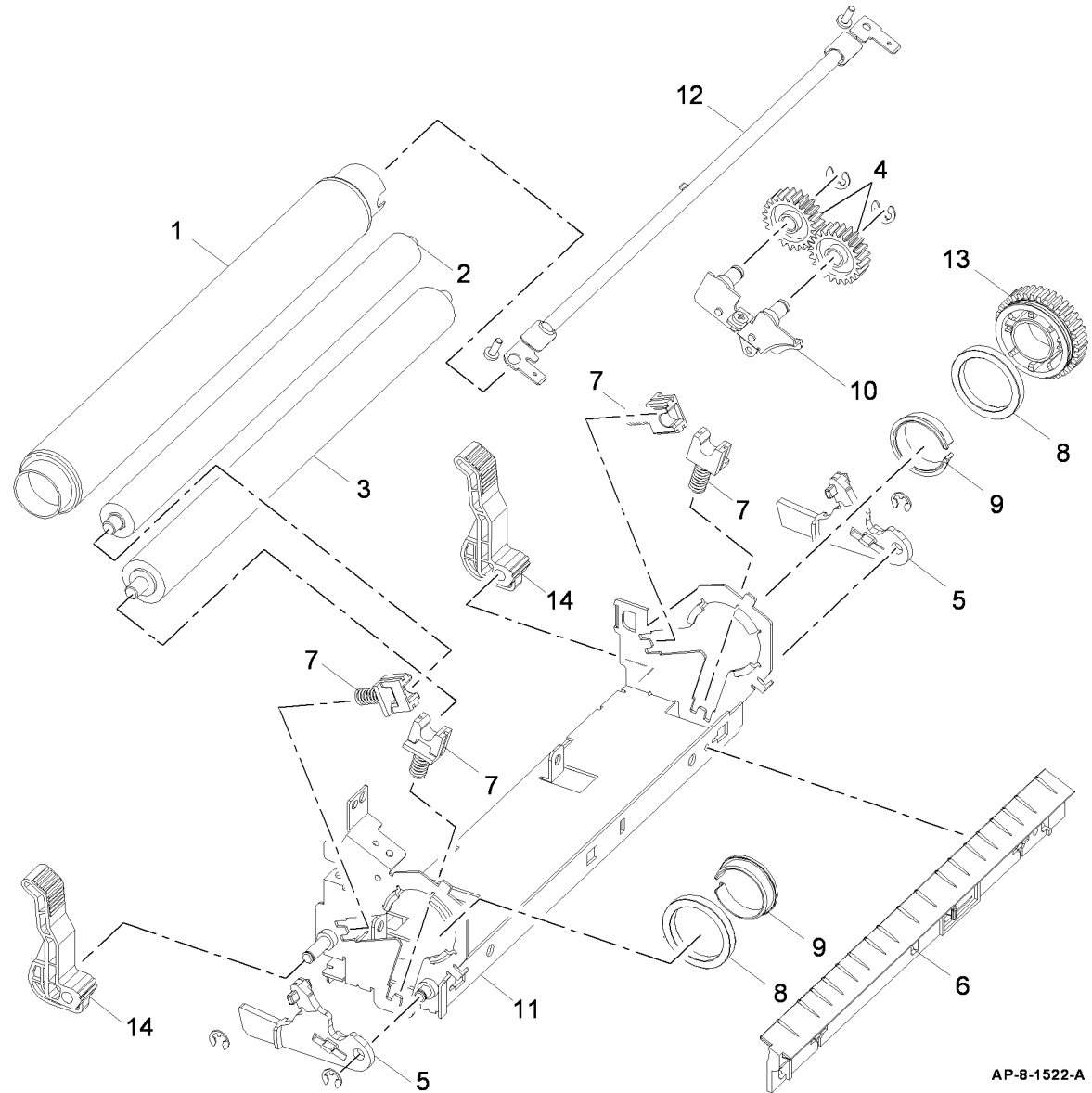

AP-8-1522-A

# PL 10.20 Duplex Drive Assembly

Item	Part	Description
1	127N07558	Duplex motor (MOT04-300) (REP 10.1)
2	127N07485	Fuser fan
3	-	Duplex motor bracket (P/O PL 10.20 Item 13)
4	127N07560	Exit motor (MOT04-200) (REP 10.2)
5	-	Exit motor bracket (P/O PL 10.20 Item 11)
6	-	Exit motor gear idler (P/O PL 10.20 Item 11)
7	-	Exit motor clutch (P/O PL 10.20 Item 11)
8	-	Exit motor clutch gear (P/O PL 10.20 Item 11)
9	-	Fuser connection gear (P/O PL 10.20 Item 11)
10	-	Exit motor intermediate gear (P/O PL 10.20 Item 11)
11	007N01594	Exit drive assembly (REP 10.2)
12	-	Duplex drive gear (P/O PL 10.20 Item 13)
13	007N01592	Duplex drive assembly (REP 10.1)

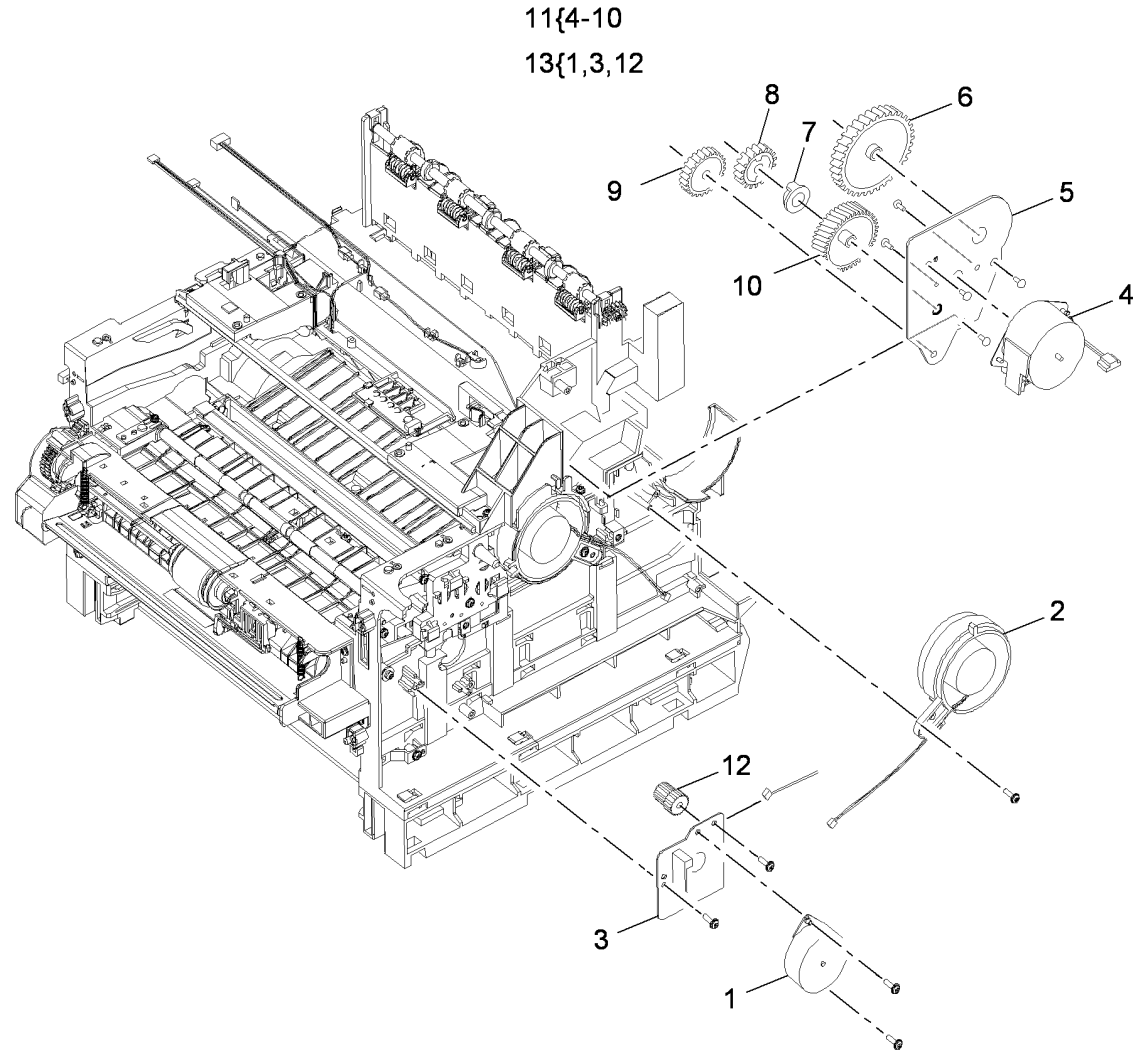

AP-8-1510-A

# PL 10.22 Front Duplex Guide Assembly

Item	Part	Description
1	130N01274	Tray 1 paper empty sensor (Q07-110)
2	-	KL-clip (P/O PL 10.22 Item 15)
3	-	Front duplex guide (P/O PL 10.22 Item 15)
4	-	Sheet guide (P/O PL 10.22 Item 15)
5	-	Static eliminator (P/O PL 10.22 Item 15)
6	-	Duplex assembly clamp (P/O PL 10.22 Item 15)
7	-	Cam (P/O PL 10.22 Item 15)
8	-	Pickup shaft (P/O PL 10.22 Item 15)
9	-	Feed roll (P/O PL 10.22 Item 15)
10	-	Tray 1 paper empty sensor actuator (P/O PL 10.22 Item 15)
11	-	Static eliminator (P/O PL 10.22 Item 15)
12	-	Feed roll holder (P/O PL 10.22 Item 15)
13	-	Bearing (P/O PL 10.22 Item 15)
14	022N02343	Tray 1 pickup roll (NOTE)
15	032N00490	Front duplex guide assembly (Complete) (REP 10.3)

**NOTE:** HFSI. To reset the HFSI count go to GP 16.

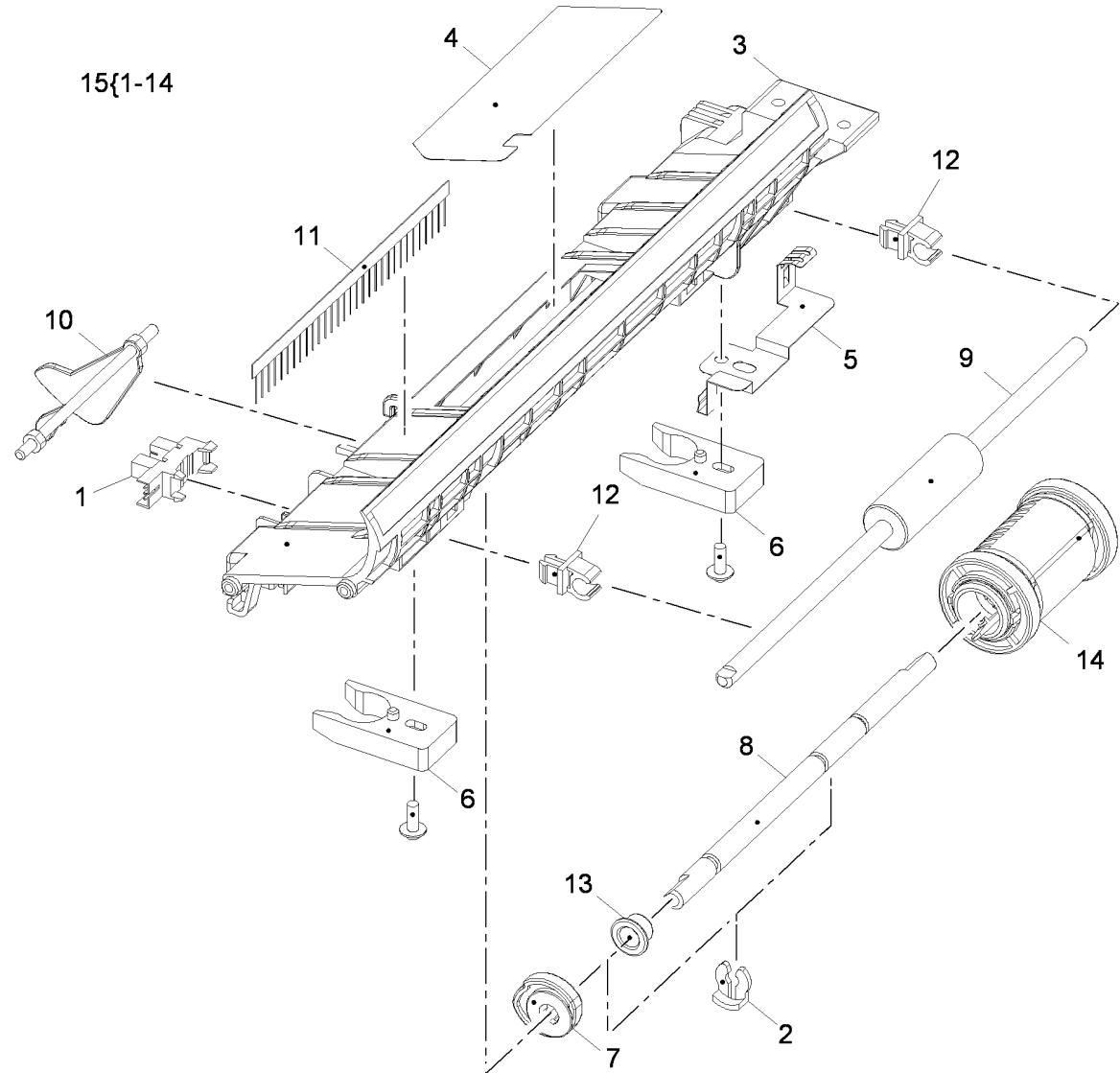

AP-8-1520-A

## PL 10.23 Duplex Assembly (1 of 3)

Item	Part	Description
1	-	Duplex frame (P/O PL 10.23 Item 18)
2	-	Idler spring (P/O PL 10.23 Item 18)
3	-	Bush (P/O PL 10.23 Item 18)
4	-	Upper guide (P/O PL 10.23 Item 18)
5	-	Alignment bracket (P/O PL 10.23 Item 18)
6	-	Spring assembly (P/O PL 10.23 Item 18)
7	-	Exit gear (P/O PL 10.23 Item 18)
8	-	Idler shaft (P/O PL 10.23 Item 18)
9	-	Duplex roll idler (P/O PL 10.23 Item 18)
10	-	Pulley (P/O PL 10.23 Item 18)
11	-	Snap on washer (P/O PL 10.23 Item 18)
12	-	Drive drive belt (P/O PL 10.23 Item 18)
13	-	Rear duplex roll (P/O PL 10.23 Item 18)
14	-	Front duplex roll (P/O PL 10.23 Item 18)
15	-	Static eliminator (P/O PL 10.23 Item 18)
16	-	Noise insulation (P/O PL 10.23 Item 18)
17	-	Noise insulation cover (P/O PL 10.23 Item 18)
18	101N01420	Duplex assembly (Complete)

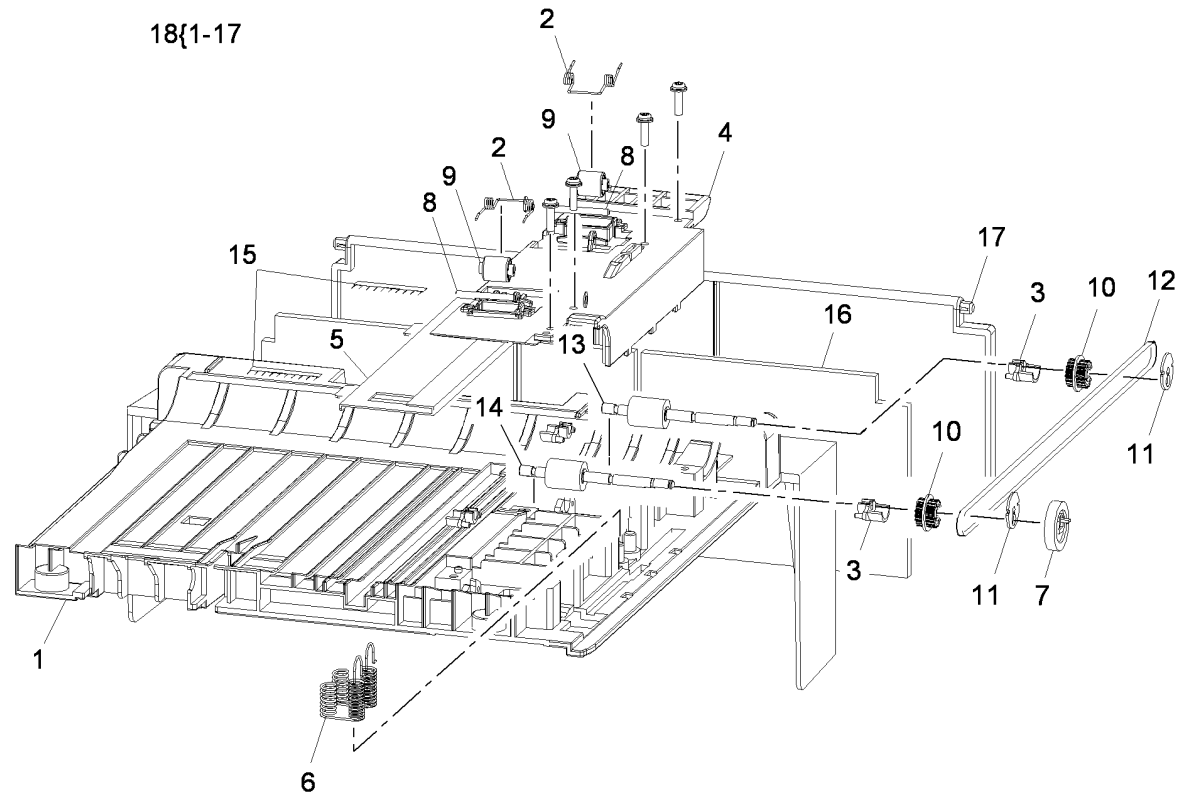

AP-8-1519-A

## PL 10.25 Exit Feed Assembly

Item	Part	Description
1	-	Exit idler spring (P/O PL 10.25 Item 21)
2	-	Exit idler holder (P/O PL 10.25 Item 21)
3	-	Primary exit idler (P/O PL 10.25 Item 21)
4	-	Secondary exit idler (P/O PL 10.25 Item 21)
5	-	Thermistor (Not Spared) (NOTE)
6	-	Thermistor harness (Not Spared) (NOTE)
7	-	CRUM PWB (REF: PL 9.10 Item 7)
8	152N11754	Fuser terminal (REP 10.5)
9	-	Ground strip (Not Spared)
10	-	Ground strip (Not Spared)
11	-	LSU support plate (Not Spared)
12	-	Exit roll holder (Not Spared)
13	-	Transport roll idler holder (Not Spared)
14	-	Transport roll idler spring (Not Spared)
15	-	Transport roll idler (Not Spared)
16	-	Transport roll idler shaft (Not Spared)
17	-	Document path idler roll (Not Spared)
18	-	Exit roll gear (Not Spared)
19	-	Main housing (Not Spared)
20	-	Housing spring (Not Spared)
21	130N01531	Idler assembly (REP 10.4)
22	022N02344	Exit roll (REP 10.4)

**NOTE:** Shown for reference only. For future use.

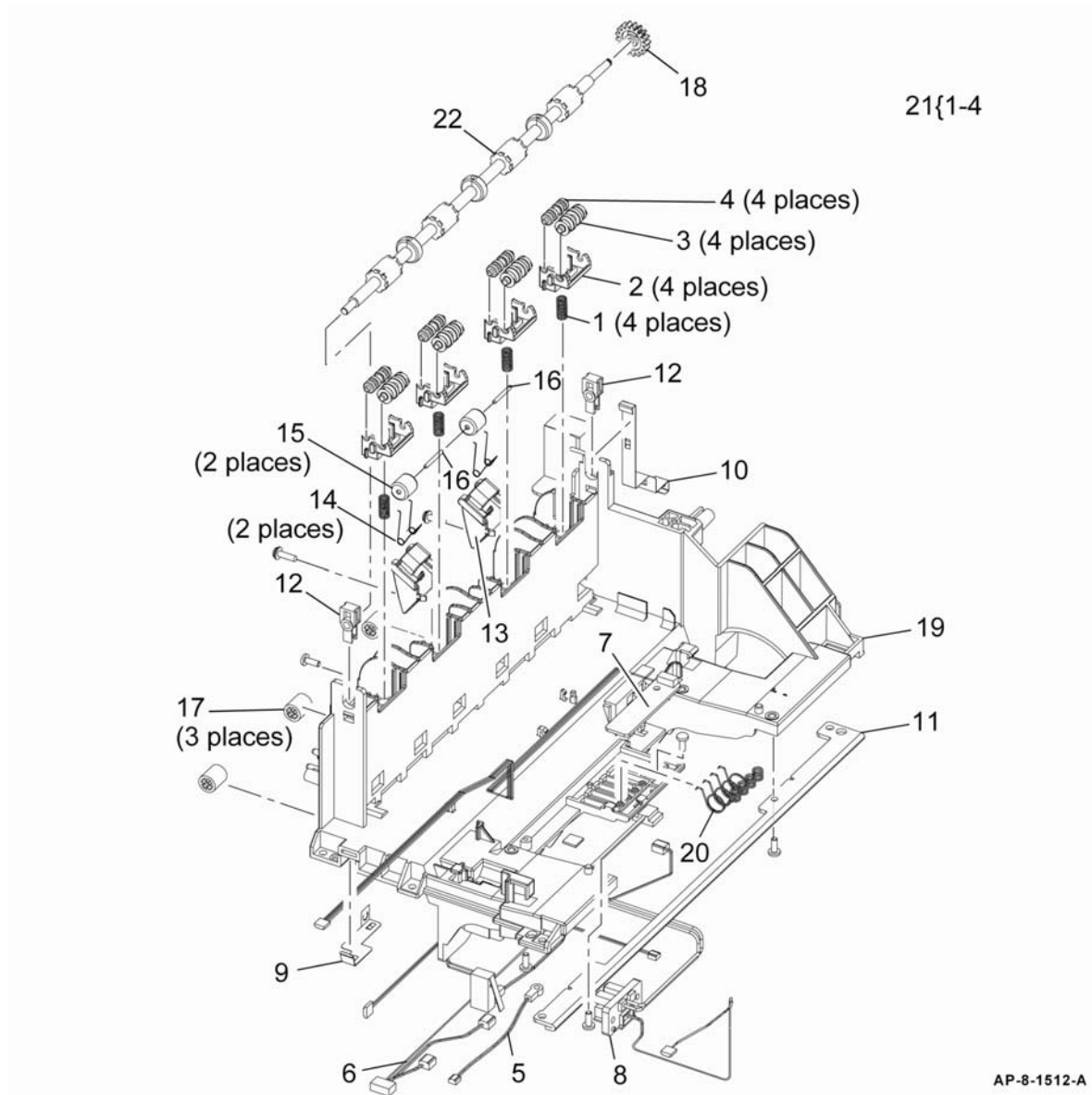

AP-8-1512-A

## PL 10.30 Exit Cover Assembly

Item	Part	Description
1	–	Exit cover (P/O PL 10.30 Item 12)
2	130N01274	Out bin full sensor (Q08-720)
3	–	Out bin full sensor harness (P/O PL 10.30 Item 12)
4	120N00517	Out bin full sensor actuator
5	–	Transport roll holder (P/O PL 10.30 Item 12)
6	–	Transport roll (P/O PL 10.30 Item 12)
7	–	Transport roll idler gear (P/O PL 10.30 Item 12)
8	–	Transport roll gear (P/O PL 10.30 Item 12)
9	–	Ground strip (P/O PL 10.30 Item 12)
10	125N00094	Static eliminator
11	–	Damper (P/O PL 10.30 Item 12)
12	002N02714	Exit cover assembly (Complete)

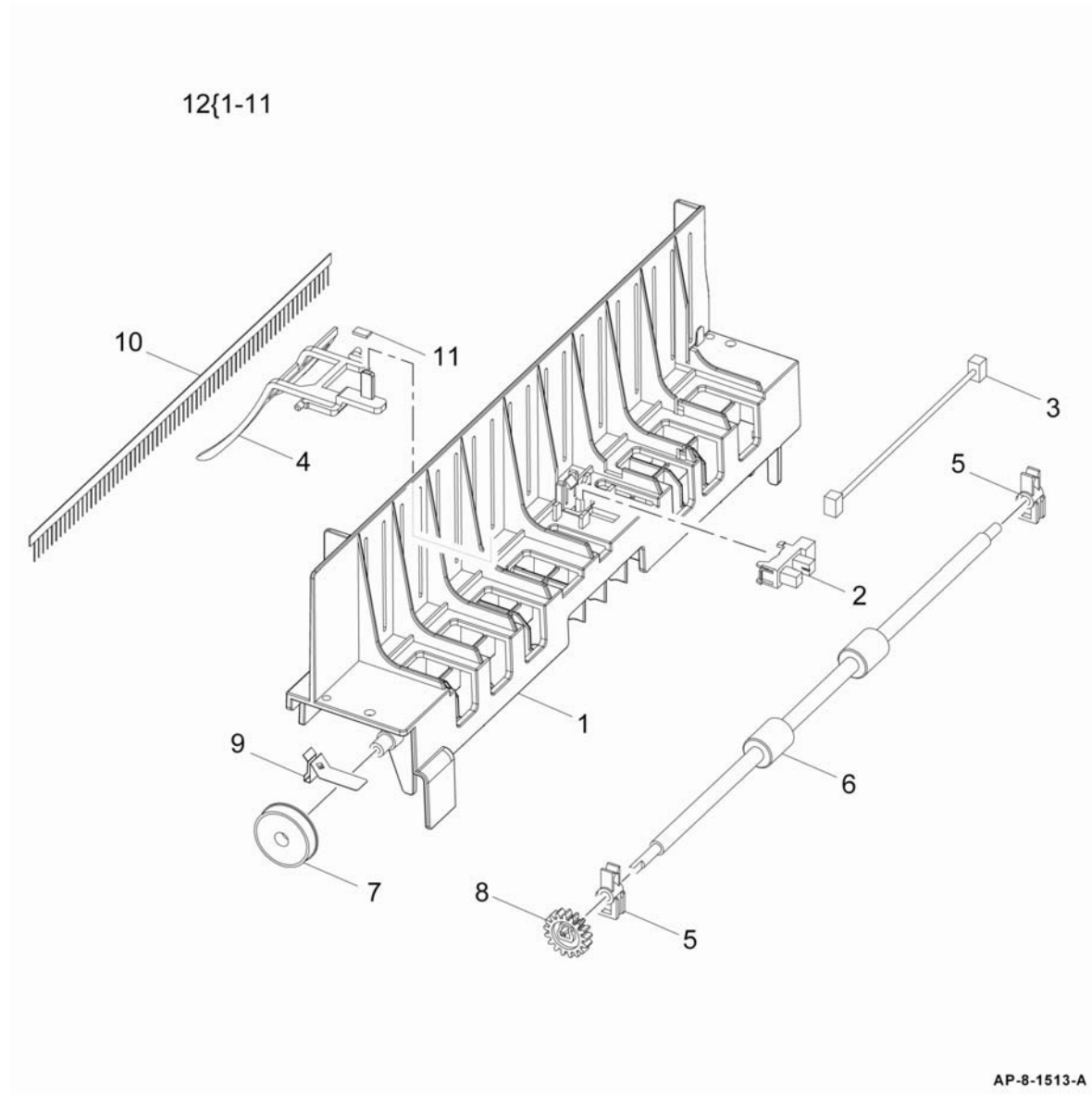

## PL 11.10 Stapler Assembly

Item	Part	Description
1	-	Stapler housing bracket (Not Spared)
2	-	Stapler door interlock switch (Not Spared)
3	029N00395	Stapler
4	-	Stapler assembly (Complete) (Not Spared)
5	-	Stapler harness (Not Spared)

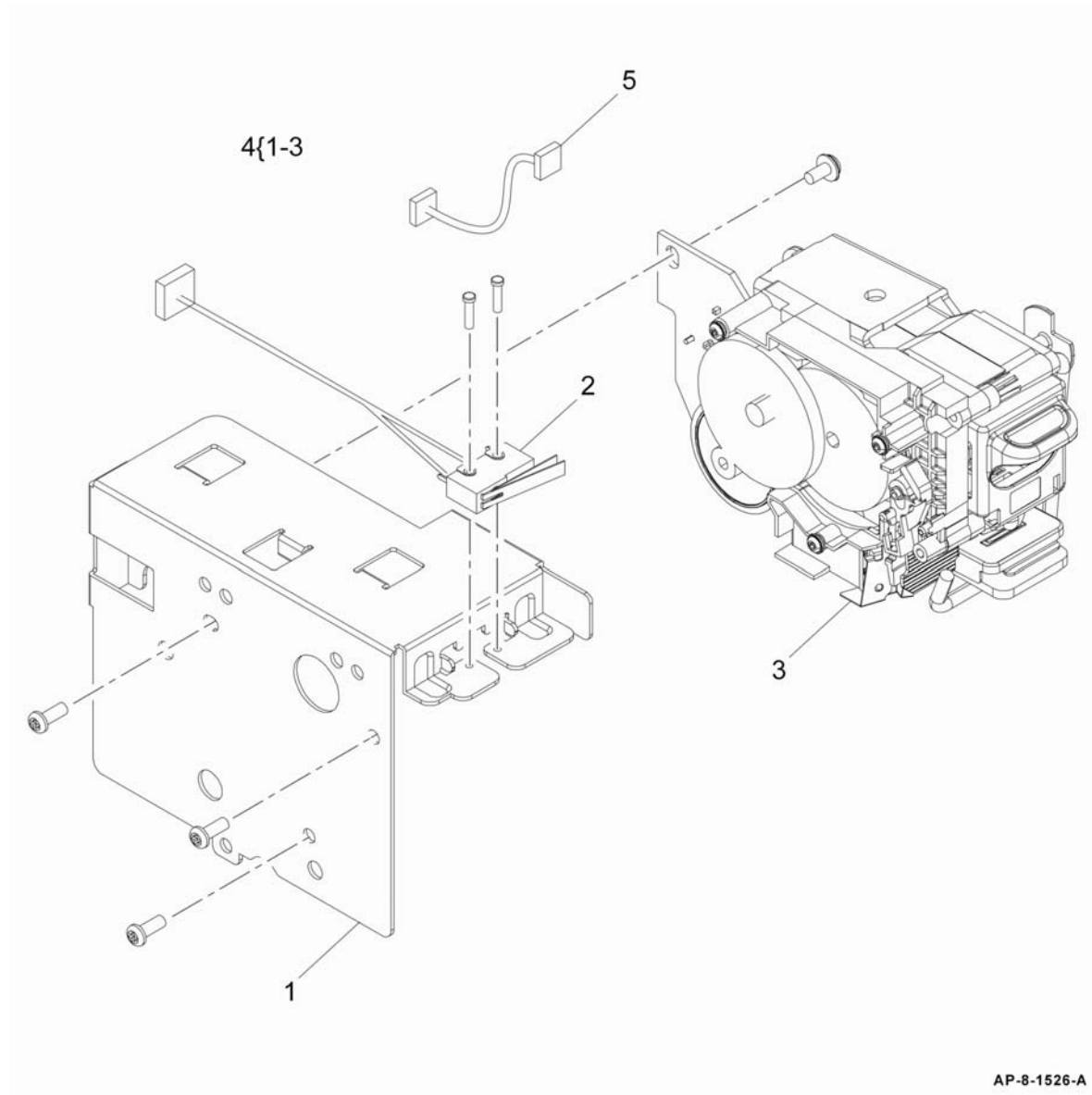

## PL 14.10 Scanner Assembly

Item	Part	Description
1	–	Scanner base (P/O PL 14.10 Item 26)
2	–	UI base (P/O PL 14.10 Item 26)
3	–	LCD support (P/O PL 14.10 Item 26)
4	130N01274	CCD home sensor (A), Platen cover sensor (B) (REP 14.2)
5	–	Ferrite (P/O PL 14.10 Item 26)
6	127N07564	Scan motor drive assembly
7	–	Ground strip (P/O PL 14.10 Item 26)
8	133N23230	CCD module (REP 14.2)
9	–	Ground strip (P/O PL 14.10 Item 26)
10	127N07561	Scan motor
11	–	Platen cover sensor actuator (P/O PL 14.10 Item 26)
12	–	Platen cover sensor actuator spring (P/O PL 14.10 Item 26)
13	152N11750	DADF connector
14	–	Drive belt spring (P/O PL 14.10 Item 26)
15	–	Pulley shaft (P/O PL 14.10 Item 26)
16	–	Pulley (lower) (P/O PL 14.10 Item 26)
17	109N00542	CCD module belt
18	–	Pulley (upper) (P/O PL 14.10 Item 26)
19	–	CCD module guide rail (P/O PL 14.10 Item 26)
20	002N02719	Scanner cover (REP 14.2)
21	–	Scanner lock bracket (P/O PL 14.10 Item 26)
22	–	Scanner lock (P/O PL 14.10 Item 26)
23	117N01788	CCD module cable
24	–	Left trim (P/O PL 14.10 Item 26)
25	–	Right trim (P/O PL 14.10 Item 26)
26	109N00688	Scanner assembly (Complete) (REP 14.1)

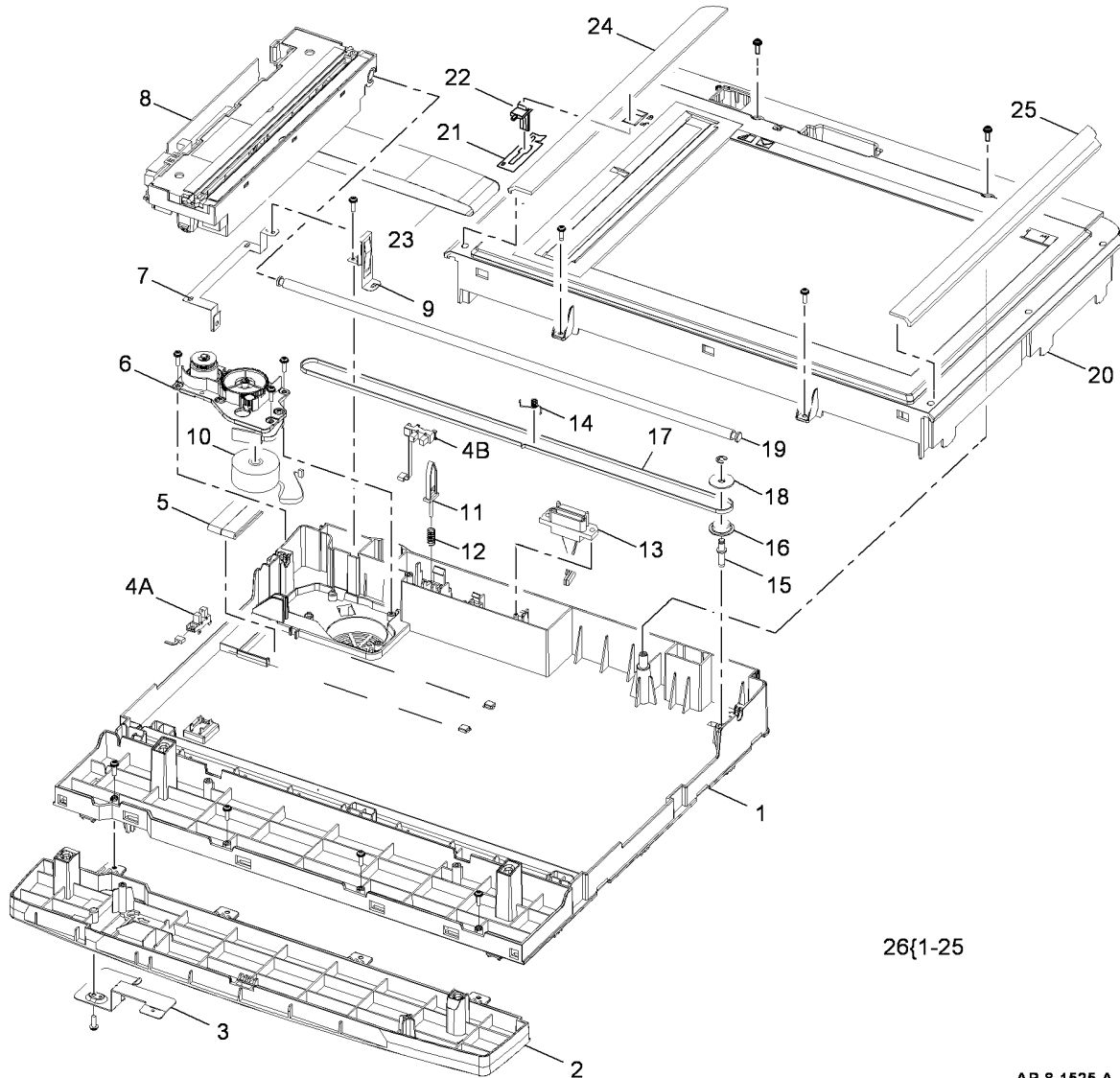

AP-8-1525-A

## PL 28.10 Main Covers

Item	Part	Description
1	002N02713	Right cover (REP 28.1)
2	-	Exit cover assembly (REF: PL 10.30 Item 12)
3	-	Out-bin assembly (Not Spared) (REP 28.2)
4	002N02715	Left cover (REP 28.1)
5	-	Rear cover assembly (REF: PL 8.20 Item 11)
6	002N02717	Front mid cover (REP 28.3)
7	-	Front cover assembly (Not Spared)
8	-	Front cover interlock switch actuator (Not Spared)
9	-	Stapler door (Not Spared)
10	-	Main PWB bracket (REF: PL 3.10 Item 9)
11	-	DIMM cover (Not Spared) (REP 28.1)
12	-	Left cover assembly (Not Spared) (REP 28.1)

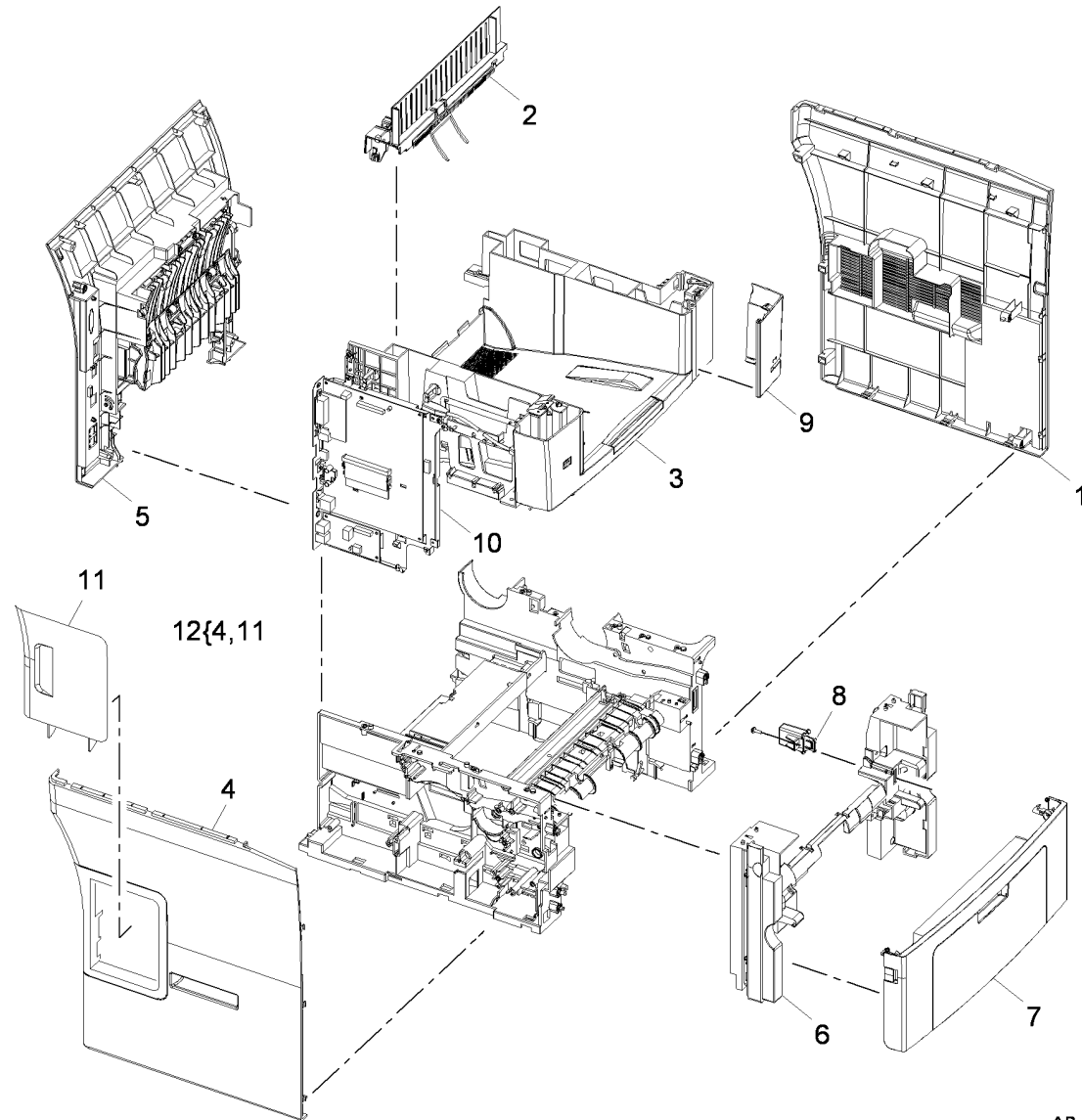

AP-8-1517-A



## 6 General Procedures and Information

### GP 1 - GP 18

GP 1 Diagnostics Entry .....	6-3
GP 2 Fault Codes and History Files .....	6-6
GP 3 Machine Status .....	6-7
GP 4 System Administration Tools .....	6-9
GP 5 Reports .....	6-12
GP 6 Firmware Upgrade .....	6-13
GP 7 Machine Specifications .....	6-14
GP 8 DADF Document Feeding Specifications .....	6-16
GP 9 Paper and Media Specifications .....	6-16
GP 10 General Disassembly Precautions .....	6-18
GP 11 Service Information .....	6-18
GP 12 User Interface Tests Description .....	6-19
GP 13 Installation Space Requirements .....	6-20
GP 14 Glossary of Terms, Acronyms and Abbreviations .....	6-22
GP 15 Shading Test .....	6-29
GP 16 High Frequency Service Items .....	6-29
GP 17 Restriction of Hazardous Substances (RoHS) .....	6-30
GP 18 Scan Edge .....	6-30

### Diagnostic Codes

dC001 Reset Auditron Master PIN .....	6-31
dC109 Embedded Fax Protocol Report .....	6-31
dC131 NVM Read/Write .....	6-33
dC132 NVM Initialization .....	6-36
dC305 UI Test .....	6-38
dC330 Component Control .....	6-38
dC606 Internal Print Test Patterns .....	6-42

### Change Tags

Change Tags .....	6-43
Machine Tags .....	6-43

# GP 1 Diagnostics Entry

## Purpose

This procedure describes the items that follow:

- How to Enter Diagnostics.
- Diagnostic Screen.
- How to Exit From Diagnostics.

**NOTE:** When the diagnostic mode is entered, all existing copy jobs are cancelled. If the machine is networked, the current job will be completed before diagnostic mode is entered. All scheduled jobs will be held in a queue due to the machine being offline.

## Procedure

### How to Enter Diagnostics

1. Switch on the machine.
2. When the machine is in the ready state, press and hold the # key, then press the **Log In/Out** key. The Diagnostic Login window will open.
3. Enter the password (default is 1934). Touch the Enter button on the UI.

**NOTE:** Press the C Key to clear an incorrect entry. Three incorrect entries will cause the entry screen to lock for three minutes.

4. The Diagnostic Screen will be displayed.
5. To exit diagnostics, refer to How to Exit From Diagnostics.

### Diagnostic Screen

The Diagnostic screen gives access to the diagnostic menu, refer to Table 1. The diagnostic routines available are:

Copier Routines:

- dC131 NVM Read/Write.
- dC132 NVM Initialization - Copier
- dC305 UI Test.
- dC330 Component Control.

Network Routines:

- dC132 NVM Initialization - Network.

Fax Routines:

- dC109 Embedded Fax Protocol Report.
- dC131 NVM Read/Write.
- dC132 NVM Initialization - Fax Card.
- dC330 Component Control.

Other Routines:

- dC001 Reset Auditron Master PIN
- dC606 Print Test Patterns
- Shading Test (GP 15)
- Scan Edge (GP 18)

### How to Exit From Diagnostics

1. Touch the Exit button to exit from the dC procedures.

2. Touch the Call Closeout button to exit diagnostics.
3. When the Call Closeout window is displayed, the options that follow are available:
  - Reset Counters. The default is No. If the Yes button is touched, the counters that follow are reset:
    - Error Messages.
    - Last 40 Error Messages.
    - Total Images made after the last service call.
  - Reboot copier. The default is Yes. The image processor, IOT, scanner, UI and DADF are rebooted. Touch the No button if the machine reboot is not needed.

**NOTE:** If the machine is not rebooted, the exit time from diagnostics is decreased.

4. Touch the Closeout button to complete the exit procedure.

**Table 1 Diagnostic menu**

1st Level	2nd Level	3rd Level	4th Level
<b>Service Info (GP 11)</b>	HFSI	Reset / Edit	-
-	Software Versions	-	<b>NOTE:</b> Only the categories for the installed options are displayed.
-	Usage Counters	Display Usage Counters	Print
-	-	-	Update
-	Machine Serial No.:	-	-
-	Images Since Last Call:	-	-
-	Network IP Address:	-	-
-	System Administrator Passcode	-	-
<b>Fault History</b>	Fault Log	View Fault Details	-
-	-	Erase History	-
-	-	Order by Time / Order by Code	-
-	Fault Counters	Non Zero Fault Counters / All Fault Counters	-
-	-	Fault Chain	01 Electrical
-	-	-	02 USB
-	-	-	03 Run Control
-	-	-	04 Drives and Fans
-	-	-	05 DADF
-	-	-	06 LSU (ROS)
-	-	-	07 Paper Tray
-	-	-	08 Paper Feed
-	-	-	09 Xerography
-	-	-	10 Fusing
-	-	-	14 Scanner
-	-	-	15 Scan to Email
-	-	-	17 Network
-	-	-	20 Fax
<b>Diagnostic Routines</b>	Copier Routines	dC131 NVM Read/Write	-
-	-	dC132 NVM Initialization - Copier	All Copier NVM
-	-	-	Machine Variable NVM
-	-	-	SA/KO Dust Off
-	-	-	System Counters Dust Off
-	-	dC305 UI Test	User Interface Button Test
-	-	-	Audio Tone Test
-	-	-	LED Indicator Test
-	-	-	Touch Area Test
-	-	-	Display Pixel Test
-	-	-	Video Memory Test

**Table 1 Diagnostic menu**

1st Level	2nd Level	3rd Level	4th Level
-	-	-	Reset User Interface
-	-	-	Application Checksum Verification
-	-	-	Touch Screen Calibration
-	-	dC330 Component Control	-
-	Network Routines	dC132 NVM Initialization - Network	All Network NVM
-	Fax dC Routines	dC109 Protocol Report	-
-	-	dC131 NVM Read/Write	-
-	-	dC132 NVM Initialisation - Fax Card	Kill All
-	-	-	All Fax Directories
-	-	-	Fax Job NVM
-	-	-	Fax Configuration NVM
-	-	-	Fax SA/KO Settings NVM
-	-	dC330 Component Control	-
-	Other Routines	dC001 Reset Auditron Master PIN	-
-	-	dC606 Print Test Patterns	1-19
-	-	Shading Test (GP 15)	Shade and Print Report
-	-	-	Print Last Shade Report
-	-	Scan Edge (GP 18)	-

## GP 2 Fault Codes and History Files

### Purpose

To explain the chain code structure and describe fault history contents.

### Description

- To access some history files from the UI, refer to GP 3 machine Status.
- To view all the machine fault history, clear the last 40 faults, or reset each of the fault counters, refer to Diagnostics Fault History.
- For information on fault codes, refer to Function and Fault Codes.

### Procedure

1. Enter diagnostics, GP 1.
2. Select the **Fault History** tab.
3. Select **Fault Log** or **Fault Counters** button as appropriate and follow the on screen instructions.

### Function and Fault Codes

Refer to Table 1 Function and fault code prefixes. Also known as the chain code.

**NOTE:** Where possible, the component related fault codes are the same as the component control codes.

Table 1 Function and fault code prefixes

Chain Code	Function
01	Electrical
02	USB
03	Run control
04	Drives and fans
05	DADF
06	LSU (ROS)
07	Paper tray
08	Paper feed
09	Xerography
10	Fusing
14	Scanner
15	Scan to Email
17	Network
20	Fax

### Machine Status Button Fault History

The most recent fault and status codes can be displayed on the UI. Press the **Machine Status** key, refer to GP 3. Touch the 'Error Messages' tab on the UI, then select, as appropriate:

- All Faults.
- Active Messages - status codes and a status message.
- Event Log.

## Diagnostics Fault History

### Description

The diagnostics Fault History window contains two options:

1. **Fault Log** - Displays the faults in time or code order. Displays a selected fault in detail. Permits deletion of the entire history file.
2. **Fault Counters** - Displays the title buttons for the faults separated into chains. Selection of a chain will display the fault detail.

**NOTE:** Categories that do not exist on the machine will not be displayed.

## GP 3 Machine Status

### Purpose

To describe the machine information that is available.

### Procedure

Perform the following:

1. Press the **Machine Status** key.
2. Navigate to the required option, refer to Table 1.

**Table 1 Diagnostic menu**

Function	1st Level	2nd Level	3rd Level	4th Level	5th Level
<b>Machine Information</b>	General Information	Customer Support	-	-	-
-	-	Machine Serial Number	-	-	-
-	-	System Software Version	-	-	-
-	Network Information	IP Address	-	-	-
-	-	Host Name	-	-	-
-	-	Fax Numbers	-	-	-
-	Paper Tray Status	-	-	-	-
-	Information Pages (GP 5)	Call For Assistance	-	-	-
-	-	Help List	-	-	-
-	-	Error Messages	-	-	-
-	-	Last 40 Error Messages	-	-	-
-	-	System Configuration	-	-	-
-	-	E-mail Send	-	-	-
-	-	User Authentication	-	-	-
-	-	Local Address Book Members	-	-	-
-	-	Group Address Book Members	-	-	-
-	-	All Above Reports	-	-	-
-	-	Fax Phone Book	-	-	-
-	-	Fax Transmission	-	-	-
-	-	Fax Receive	-	-	-
-	-	Fax Broadcast	-	-	-
-	-	Fax Protocol	-	-	-
-	-	Fax Multipoll	-	-	-
-	-	Junk Fax List	-	-	-
-	-	Pending Jobs	-	-	-
-	-	Fax Options	-	-	-
-	Machine Details	Customer Support	-	-	-
-	-	Supplies Number	-	-	-
-	-	Machine Serial Number	-	-	-
-	-	System Software Version	-	-	-
-	-	Customer Asset Tag Number	-	-	-
-	-	Xerox Asset Tag Number	-	-	-
-	-	Machine Hardware Options	-	-	-
-	-	Machine Software Versions	-	-	-
-	Usage Counters	-	-	-	-
<b>Error Messages</b>	All Faults	Fault Description	-	-	-

Table 1 Diagnostic menu

Function	1st Level	2nd Level	3rd Level	4th Level	5th Level
-	Active Messages	-	-	-	-
-	Event Log	Order By Time / Order By Code	-	-	-
<b>Service Information</b>	Supply / Measure / Count	-	-	-	-

## GP 4 System Administration Tools

### Purpose

To describe the system administration tools that are available.

### Procedure

Perform the following:

1. Press the **Log In/Out** key.

2. Enter the customers password (default is 1111). Touch the Enter button on the UI.
3. Select the **Tools** tab, refer to Table 1.

**NOTE:** The Machine Information, Faults and Service Information tabs are accessible without entering System Administration Tools. Go to GP 3 Machine Status.

Table 1 Diagnostic menu

1st Level	2nd Level	3rd Level	4th Level	5th Level	6th Level
Device Settings	General	Energy Saver	5 to 120 Minutes	-	-
-	-	Set Date & Time	mm/dd/yy / dd/mm/yy / yy/mm/dd	-	-
-	-	-	Month / Day / Year	-	-
-	-	GMT Offset	-12 to 14.0 Hours	-	-
-	-	Language Default	US English / Italian / Danish / Greek / Polish / French / Dutch / Swedish / Russian / Hungarian / German / Portuguese / Finnish / Turkish / Romanian / Spanish / Brazilian Portuguese / Norwegian / Czech / Catalan	-	-
-	-	Xerox Customer Support	Customer Support Telephone Number / Supplies Telephone Number / Customer Asset TAG Number / Xerox Asset TAG Number	-	-
-	-	System Administration Reports	Machine Configuration / SMTP Log / LDAP Log / Connectivity Log / Network Authentication Log	-	-
-	-	-	Do not Print Configuration Report At Power On / Print Configuration Report At Power On	-	-
-	-	Altitude Adjustment	Enable / Disable	-	-
-	-	Contention Management	Priority / First In, First Out	-	-
Paper Tray Management	Paper Setting	Default Stock	Stock Type	Plain Paper / Lightweight / Cotton / Colored / Pre-printed / Recycled / Transparency / Labels / Card Stock / Bond / Archive / Envelopes / Heavyweight / Custom 1 / Custom 2 / Custom 3 / Custom 4 / Custom 5 / Custom 6 / Custom 7 / Other	-

Table 1 Diagnostic menu

1st Level	2nd Level	3rd Level	4th Level	5th Level	6th Level
-	-	-	Stock Colour	White / Blue / Yellow / Green / Pink / Clear / Ivory / Gray / Buff / Goldenrod / Red / Orange / Custom 1 / Custom 2/ Custom 3 / Custom 4 / Custom 5 / Custom 6 / Custom 7 / Other	-
-	-	Paper Substitution	On / Off	-	-
-	-	Default Paper Size	8.5x11 / A4	-	-
-	Tray Setting	Auto Tray	On / Off	-	-
-	-	Tray Confirmation Messages	Tray 1 / Tray 2 / Bypass	On / Off	-
User Interface	General	Measurements	Units	Inches / mm	-
-	-	-	Numeric Separator	Comma / Period	-
-	-	Audio Tones	Fault Tones / Conflict Tones / Selection Tone	Off / Low / Medium / High / Test	-
-	-	Screen Default	Entry Screen Default	Features / Machine Status / Job Status / All Services	-
-	-	-	Job Status Default	Incomplete Printing Jobs / Incomplete Non-Printing Jobs / All Incomplete Jobs / Completed Printing Jobs / Completed Non-Printing Jobs / All Completed Jobs	-
-	-	-	Feature Default And Priority Order	Copy / ID Card Copy / Fax / E-mail / Network Scanning	-
-	-	SFO	SFO Number (00 - 99)	Enable / Disable	-
-	-	-	Print SFO Report	-	-
Connectivity And Network Setup	General	Physical Media	Auto / 10 Mbps Half-Duplex / 10 Mbps Full-Duplex / 100 Mbps Half-Duplex / 100 Mbps Full-Duplex	-	-
-	-	Software Upgrade	On / Off	-	-
Accounting	Accounting Enablement	Authentication Mode	Auditron / Xerox Standard Accounting / Network Accounting	On / Off	-
-	-	Internal Auditron Setup	Auditron Initialization	User Accounts	1-400
-	-	-	-	General Accounts	0-6782
-	-	-	-	Group Accounts	1-100
-	-	-	-	Reset All Counters	-
-	-	-	-	Initialize Auditron	-
-	-	-	Auditron Group Accounts	Next Open Account / Next Active Account / Previous Account (1-100)	1-100
-	-	-	User Accounts And Access Rights	Next Open Account / Next Active / Previous Account	1-400
-	-	-	-	Access	General Account Access / Multiple Group Account Access

**Table 1 Diagnostic menu**

1st Level	2nd Level	3rd Level	4th Level	5th Level	6th Level
-	-	-	Auditron General Accounts	Next Open Account / Next Active / Previous Account	1-50
-	-	-	Auditron Reports	Print Account Report	-
-	-	-	Auditron Service Mode	Copy Only / Copy And Fax	-
Security Settings	Authentication	Job Operation Rights	All Users / System Administrator Only	-	-
-	Image Overwrite Security	Immediate Overwrite	Enable / Disable	-	-
-	-	-	On Demand Overwrite	Standard / Full	-

## GP 5 Reports

### Purpose

To give details of the reports that are available in machine Information, refer to GP 3:

- Call for Assistance
- Help List
- Error Messages
- Last 40 Error Messages
- System Configuration
- Email Send
- User Authentication
- Local Address Book Members
- Group Address Book Members
- All Above Reports
- Fax Phone Book
- Fax Transmission
- Fax Receive
- Fax Broadcast
- Fax Protocol
- Fax Multipoll
- Junk Fax List
- Pending Jobs
- Fax Options
- Billing/Meters
- Auditron
- Xerox Standard Accounting
- All Accounting Reports
- Email Confirmation
- All Email Reports

### Call for Assistance

This report shows all the information required by the call center when the customer registers a request for service.

### Help List

This report shows a brief description of the machines basic functions and commands. It adds or subtracts features from the report, based upon machine configuration. It can be used as a quick reference guide.

### Error Messages

This report shows all the fault codes generated by the machine.

### Last 40 Error Messages

This report shows the last 40 fault codes generated by the machine.

## System Configuration

This report shows the user system data settings and the machine settings.

### Email Send

This report shows specific information concerning scan to email activities.

### User Authentication

This report shows the authentication for scan to email.

### Local Address Book Members

This report shows all email addresses contained in the local address book.

### Group Address Book Members

This report shows all groups and the email addresses associated with each group in the group address book.

### All Above Reports

The machine will print all reports listed above.

### Fax Phone Book

This report shows all telephone numbers stored in the machine.

### Fax Transmission

This report shows the most recent 50 fax transmissions.

### Fax Receive

This report shows the most recent 50 fax receptions.

### Fax Broadcast

This report shows the success or failure of a specific fax job sent to multiple destinations.

### Fax Protocol

This report shows the protocol information about the last fax job. Refer to dC109 Embedded Fax Protocol Report.

### Fax Multipoll

This report shows the success or failure of a specific polling fax job sent to multiple destinations.

### Junk Fax List

This report shows the junk faxes.

### Pending Jobs

This report shows specific information about document stored for delayed activity.

## **Fax Options**

This report shows the different options available for the fax and their current settings.

## **Billing/Meters**

This report shows specific information about the machines total print count.

## **Auditron**

This report shows the active electronic auditron group accounts and their current image counters for each available service.

## **Xerox Standard Accounting**

This report shows the user account activity. Reports are available for user accounts, general accounts and group accounts.

## **All Accounting Reports**

The machine will print the Auditron list and Xerox Standard Accounting list.

## **Email Confirmation**

This report prints after connecting to the mail server.

## **All Email Reports**

This function will print all available Email reports.

## **GP 6 Firmware Upgrade**

### **Purpose**

To give details of the firmware upgrade procedure.

### **Procedure**

The firmware upgrade is initiated locally from a USB thumbdrive through the standard thumbdrive port.

Perform the following:

1. Load the firmware onto a USB thumbdrive.
2. Connect the USB thumbdrive to the standard thumbdrive port on the front of the machine.
3. Select **Print from USB**.
4. Select **USB Drive**.
5. From the displayed list, navigate to the relevant firmware file. Select the firmware file.
6. Select **Add**. The firmware file will be added to the print list.
7. Select **Done**. The print list will be displayed.
8. Select the firmware file to be downloaded to the machine. Select **Add**.
9. After the firmware has been upgraded, check that the correct version is displayed in Machine Status. Refer to GP 3 Machine Status.

## GP 7 Machine Specifications

Specifications are correct at the time of publication. Machine specifications are subject to change without notice. Refer to the following tables for machine specifications:

- Table 1 General Specifications.
- Table 2 Fax Specifications.
- Table 3 Scanner Specifications.
- Table 4 Copy Specifications.
- Table 5 Telephone Specifications.
- Table 6 Consumables.
- Table 7 Fuser Operating Temperatures.
- Table 8 HVPS Output.

**Table 1 General specifications**

Item	Description
Configuration	Desktop with 1 tray. Optional 2nd tray. Optional stand.
Operation System	Windows 95/98/2000/NT4.0/Win-ME/XP/Longhorn/XP 64bit/ Citrix/Vista MAC OS 8, 9, X 10.2, X 10.3 & Higher Unix/Linux
Duplex Printing	Yes
Printing Speed	35ppm for 8.5x11, 33ppm for A4
Paper Tray Capacity	520 sheets (75 gsm)
Document Capacity (Input)	DADF: 50 Sheets (50-120gsm)
Paper Capacity (Output)	Output tray 250 sheets
Convenience Stapler Capacity	20 sheets (75 gsm)
External Interface	Serial Interface: DADF, Tray 2
	USB 2.0 device
	USB 2.0 Host
	Network
	RJ45 for telephone
	Option SOK slot
CPU	360 MHz
System Memory	256Mb
Warming up Time	From power on: 85 Sec. From power save: 15 sec.
Absolute Storage Condition	Temperature: -20C to 40C, Humidity: 10% RH to 90% RH
Operating Condition	Temperature: 10C to 32C, Humidity: 20% RH to 80% RH
Recommended Operating Condition	Temperature: 16C to 30C, Humidity: 30% RH to 70% RH
Dimension (W x D x H)	Basic: 632 x 565 x 546mm (24.8 x 22.2 x 21.4 inches)
Weight	Machine: 19.1Kg (42lb) (with CRU) Tray 2: 7Kg (15.4lb)
Acoustic Noise	Less than 54dB (Copy/Printing scanning mode)
Power Rating	110VAC-127VAC: 7A (max) 220VAC-240VAC: 4.5A (max)

**Table 1 General specifications**

Item	Description
Power Consumption (printing/copying)	Avg. 750W
Power Consumption (power save)	Avg. 35W
Power Consumption (standby)	Avg. 100W
Power Consumption (peak)	1500W
LCD	800 by 480 line color TFT
Optional Memory	256Mb

**Table 2 Fax specifications**

Item	Description
Communication Standard	ITU G3, Super G3
Application Network	Standard G3 PSTN (RJ-11), PABX
Data coding (Compression)	MH/MR/MMR/JBIG/JPEG (Color/Transmission)
Modem speed	33600/31200/28800/26400/21600/14400/12000/ 9600/ 7200/4800/2400bps
Transmission Speed	Approximately 3 sec. (33,600 bps)
Effective Scanning Width	208 mm (8.2 inches)
Maximum Document Length from DADF	356 mm (14 inches)
Grayscale	256 Levels
Paper Capacity (Input)	DADF (Duplex Automatic Document Feeder): 50 Sheets (75gsm)
FAX Mode	Standard (203 x 98 dpi) Fine (203 x 196 dpi) Super Fine (Fine Photo) (300 x 300 dpi) Super Fine (406 x 392 dpi) Super Fine (600 x 600 dpi) Halftone
Memory	Fax stored on HDD (HDD= 80Gb)

**Table 3 Scanner specifications**

Item	Description
Type	Flatbed (with DADF)
Speed	Color/Mono Gray: 0.73msec/line at 600 x 600 dpi Mono Binary: 0.365msec/line at 300 x 300 dpi
Device	Color CCD (Charge Coupled Device) Module
Interface	IEEE1284 (ECP Support) USB (without HUB Mode)
Compatibility	TWAIN Standard, WIA
Optical Resolution (H X V)	600 x 600 dpi
Halftone	256 Levels
Effective Scan width	208 mm (8.2 inches)

**Table 4 Copy specifications**

Item	Description
Mode	B/W
Quality	Text/Photo/Mixed
Copy Speed	35ppm for 8.5 x 11, 33ppm for A4
Optical Resolution (H x V)	600 x 600 dpi
Multi Copy	1 to 999
Maximum Original Size	Letter
Maximum Page Size	Letter
Paper Type Selection	Plain, Cardstock, Transparency, Bond, Labels, Colored
Zoom Range	Platen: 25-400% (1% Step) DADF: 25-100% (1% Step)

**Table 5 Telephone specifications**

Item	Description
Speed Dial	200 Locations
Ringer Volume	Off, low, medium, high
Chain Dial	None
Pause	Yes, using the Pause/Redial Key

**Table 6 Consumables**

Item	Life expectancy
Print cartridge	10K prints (5K starter toner module) (5% coverage pattern)

**Table 7 Fuser operating temperatures**

Machine State or Paper Type	Environment (Up to 100 prints/up to 150 prints/after 151 prints)		
	LL	NN	HH
Machine in standby	170 deg. C	165 deg. C	160 deg. C
Plain	185/185/189 deg. C	180/180/178 deg. C	186/183/180 deg. C
Recycled	197/193/189 deg. C	194/191/187 deg. C	186/183/180 deg. C
Thick/Bond	197/194/194 deg. C	195/193/189 deg. C	188/185/182 deg. C
Thin	180/180/180 deg. C	175/175/175 deg. C	170/169/167 deg. C
Envelope	180/178/176 deg. C	170/168/165 deg. C	153/151/150 deg. C
Cardstock/Label	198/195/192 deg. C	190/185/180 deg. C	187/184/181 deg. C
OHP	150/148/146 deg. C	144/142/140 deg. C	138/136/135 deg. C

The environment acronyms are as follows:

- LL - Low temperature/low humidity.
- NN - Normal temperature/normal humidity.

- HH - High temperature/high humidity.

**Table 8 HVPS Output**

HVPS Output	Voltage
Transfer High Voltage+ (THV+)	+1300V DC +/-3%
Transfer High Voltage- (THV-)	-1200V DC +/-20%
Charge Voltage (MHV)	-1350V DC +/-20%
Developing Voltage (DEV)	-330V DC +/-3%
Supply	-530V DC +/-3%
OPC	-130V DC +/-15%
Fuser Bias	+320V DC +/-3%

## GP 8 DADF Document Feeding Specifications

### Purpose

To list the specifications of the documents that can be fed through the DADF.

### Specifications

Refer to Table 1.

**Table 1 Specifications**

Item	Specification
Length	145mm - 356mm (5.75 inches - 14inches)
Width	69.9mm - 216mm (2.75 inches - 8.5 inches)
Weight	50gsm - 120gsm (12.5lb - 28lb)
Thickness	0.07mm - 0.13mm
Curl	Less than 5mm
Input tray capacity	50 sheets of 80gsm (20lbs) paper

## GP 9 Paper and Media Specifications

### Purpose

To list the paper and media size specifications.

### Procedure

Refer to the following specifications:

- Paper Specifications
- Transparency Specification
- Envelope Specification
- Label Specification

### Paper Specifications

**NOTE:** Ensure that the paper tray settings match the paper size in the tray.

Refer to Table 1 for the paper and media sizes that can be used in the machine. Refer to Table 2 for the paper or media weight that can be used in the machine.

**Table 1 Paper and media specifications**

Paper Type	Mode	Size		Input Source		
		W x L (mm)	W x L (inch)	Bypass	Trays	Duplex
Letter	Print/Copy/Fax	215.9 x 279	8.5 x 11	X	X	X
Legal	Print/Copy/Fax	215.9 x 355.6	8.5 x 14	X	X	X
Folio	Print/Copy/Fax	216 x 330	8.5 x 13	X	X	X
Oficio	Print/Copy/Fax	216 x 343	8.5 x 13.5	X	X	X
A4	Print/Copy/Fax	210 x 297	8.27 x 11.69	X	X	X
JIS B5	Print	182 x 257	7.17 x 10.12	X	X (see NOTE 2)	X
Executive	Print	184.2 x 266.7	7.25 x 10.5	X	X (see NOTE 2)	X
A5	Print/Copy	148.5 x 210	5.85 x 8.27	X	X (see NOTE 2)	X (see NOTE 3)
Statement	Print/Copy	N/A	5.5 x 8.5	X	X (see NOTE 2)	X (see NOTE 3)
A6 CARD	Print	105 x 148.5	4.13 x 5.85	X		
Post card 4 x 6	Print	101.6 x 152.4	4 x 6	X		
Hagaki	Print	100 x 148	3.94 x 5.83	X		
Envelope B5	Print	176 x 250	N/A	X	X (see NOTE 2)	
Envelope 7-3/4	Print	98.4 x 190.5	3.88 x 7.5	X	X (see NOTE 2)	
Envelope COM-10 (see NOTE 1)	Print	105 x 241	4.12 x 9.5	X	X (see NOTE 2)	
Envelope DL	Print	110 x 220	4.33 x 8.66	X	X (see NOTE 2)	

**Table 1 Paper and media specifications**

Paper Type	Mode	Size		Input Source		
		W x L (mm)	W x L (inch)	Bypass	Trays	Duplex
Envelope C5	Print	162 x 229	6.38 x 9.02	X	X (see NOTE 2)	
Envelope C6	Print	114 x 162	N/A	X	X (see NOTE 2)	
Custom	Print	98 x 148 - 215.9 x 355.6	3.86 x 5.83 - 8.5 x 14	X	X (see NOTE 2)	

**NOTE:** 1. COM-10 envelope weight must not exceed 75 gsm (20lb).

**NOTE:** 2. Paper weight must be 60 gsm - 120 gsm (16lb - 32lb bond).

**NOTE:** 3. Long grain paper only.

**Table 2 Paper or media weights**

Paper or Media Source	Weight
Tray 1	60 - 90 gsm (16 - 24lb bond)
Tray 2	60 - 90 gsm (16 - 24lb bond)
Bypass	60 - 163 gsm (16 - 40lb bond)
Duplex	60 - 75gsm (16 - 20lb bond)

### Transparency Specification

Refer to Table 3 for the transparency sizes that can be used in the machine.

**Table 3 Transparency specifications**

Size	Weight	Curl	Shearing Angle
A4 or Letter (see NOTE)	138 - 146 gsm (37 - 39lb)	+/- 5mm	+/- 4 degrees

**NOTE:** Must be standard Xerox transparencies.

### Envelope Specification

Refer to Table 4 for the envelope sizes that can be used in the machine.

**Table 4 Envelope specifications**

Length	Width	Weight	Curl	Twist
162 x 250 mm (6.3 x 9.8 inches)	98.4 x 176 mm (3.9 x 6.9 inches)	75 - 90 gsm (20 - 24lb)	Less than 2mm	Less than 6mm

### Label Specification

Refer to Table 5 for the label sizes that can be used in the machine.

**Table 5 Label specifications**

Size	Type	Weight
A4 or Letter	Paper	120 - 150 gsm (32 - 40lb)

## GP 10 General Disassembly Precautions

### Purpose

Use this procedure when disassembling and reassembling components.

### Procedure

**NOTE:** *The close proximity of cables to moving parts makes proper routing essential. If components are removed, any cables disturbed by the procedure must be restored as close as possible to their original positions. Before removing any component from the machine, note the cable routing that will be affected.*

Whenever servicing the machine, perform the following:

1. Check to verify that jobs are not stored in memory.
2. Unplug the power cord.
3. Use a flat and clean surface.
4. Only install authorized components.
5. Do not forcibly remove plastic components.
6. Ensure all components are in their correct position.
7. When replacing screws into plastic components, turn the screw counterclockwise to engage the original thread, then turn the screw clockwise. Do not overtighten. If a new thread is cut, the plastic component will lose the ability to hold the screw. This also applies to metal components.

## GP 11 Service Information

### Purpose

To provide machine hardware and software information.

### Procedure

1. Enter Diagnostics, GP 1.
2. Select the Service Information tab
3. The following options are displayed:
  - Machine Serial Number.
  - Images Since Last Call.
  - Network IP Address.
  - System Administration Passcode.
4. Choose from the following:
  - HFSI.
  - Software versions.
  - Usage counters.

## GP 12 User Interface Tests Description

### Purpose

To describe the user interface tests that are available in GP 4 System Administration Tools and dC305.

### Procedure

Refer to the relevant procedure:

- User Interface Button Test
- Audio Tone Test
- LED Indicator Test
- Touch Area Test
- Display Pixel Test
- Video Memory Test
- Reset User Interface
- Application Checksum Verification
- Touch Screen Calibration

### User Interface Button Test

Use this test to verify that the buttons on the user interface are working correctly. After entering this test, follow the instructions displayed on the user interface to perform, then exit the test.

### Audio Tone Test

Use this test to verify that the audio tone on the user interface is working correctly. After entering this test, follow the instructions displayed on the user interface to perform, then exit the test.

### LED Indicator Test

Use this test to verify that the LEDs on the user interface is working correctly. After entering this test, follow the instructions displayed on the user interface to perform, then exit the test. Each LED will flash on for approximately 1 second, then off sequentially in a clockwise direction.

### Touch Area Test

Use this test to verify that the touch screen on the user interface is working correctly. After entering this test, follow the instructions displayed on the user interface to perform, then exit the test.

### Display Pixel Test

Use this test to verify that the liquid crystal display module (LCDM) is working correctly. After entering this test, follow the instructions displayed on the user interface to perform, then exit the test.

### Video Memory Test

Use this test to verify that the SRAM used by the video controller on the user interface is working correctly. After starting this test, each video SRAM location will be validated.

### Reset User Interface

This procedure will reset the user interface.

## Application Checksum Verification

This procedure will check the user interface application software checksum and any software in the extended memory.

## Touch Screen Calibration

Use this test to re-calibrate the touch screen. After entering this test, follow the instructions displayed on the user interface to perform, then exit the test.

## GP 13 Installation Space Requirements

### Purpose

To outline the general space requirements to enable safe use and adequate access for service.

### WARNING

Do not work in a confined space. 1 m (39 inches) space is needed for safe working.

### WARNING

USA and Canada. Do not install this machine in a hallway or exit route that does not have 1.12 m (44 inches) of space additional to the normal space requirements in front of the machine. To conform with fire regulations this additional 1.12 m (44 inches) of space is needed in front of the machine in hallway and exit routes.

### Procedure

Refer to the following:

- Machine Height
- Machine Weight
- Machine Dimensions and Installation Space Requirements

### Machine Height

#### Basic Machine

- Machine with the DADF lowered = 535mm (21 inches)
- Machine with the DADF raised = 765mm (30.1 inches)

#### Machine with Two Trays

- Machine with the DADF lowered = 662mm (26 inches)
- Machine with the DADF raised = 892mm (35.1 inches)

#### Machine with Two Trays and Stand

- Machine with the DADF lowered = 1103mm
- Machine with the DADF raised = 1333mm

### Machine Weight

- Basic machine = 28.9Kg (63.5lb)
- Tray 2 = 7Kg (15.4lb)
- Stand = 14.8Kg (32.6lb)

## Machine Dimensions and Installation Space Requirements

Table 1 shows the dimension of the machine and the installation space required for safe operation.

**NOTE:** The dimensions shown in Table 1 allow for a 1 metre (39.4 inches) minimum safety workspace around the machine. To acquire the minimum safety workspace it may be necessary to move the machine within the area specified.

Figure 1 represents a plan view of a machine installation and is to be read in conjunction with Table 1. The dimensions A and B outline a footprint of the machine within the boundary of safe operation, dimensions C and D. The dimension E indicates the area required for airflow / workspace at the rear of the machine.

**Table 1 Working space requirements**

Machine width (A)	Machine depth (B)	Install width required (C)	Install depth required (D)	Install airflow/service workspace (E)
475mm (18.7inches)	485mm (19.1 inches)	1485mm (58.4 inches)	1485mm (58.4 inches)	178mm (7 inches)

**NOTE:** The machine depth dimension does not include the stand stabilizing feet.

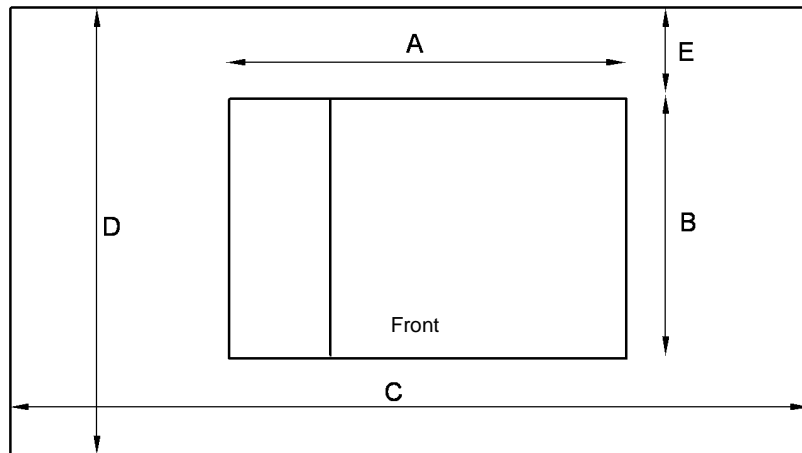

AP-1-1521-A

**Figure 1 Installation plan**

## GP 14 Glossary of Terms, Acronyms and Abbreviations

Refer to Table 1.

Where possible unit designations as appear in ISO 1000 (International Organization for Standardization) and Xerox Standard MN2-905 have been used. All measurements appear in ISO units followed by any conversion in brackets e.g.; 22.5 mm (0.885 inches)

Table 1

Term	Description
AAA	Authentication, Authorisation and Accounting
ABS	Automatic Background Suppression. ABSolute
ACK	Acknowledge
AGC	Automatic Gain Control
AHA	Advanced Hardware Architecture
AMCV	Average Monthly Copy Volume
AMPV	Average Monthly Print Volume
AMR	Automatic Meter Read
AMS	Automatic Magnification Selection
ANSI	American National Standards Institute
API	Application Programming Interface
APS	Auto Paper Selection
ARP	Address Resolution Protocol. Converts an IP address to a MAC address. See RARP.
ASIC	Application Specific Integrated Circuit
ASP	Authorized Service Provider
ASTM	American Standard Test Method
ATPD	Across The Process Direction
AZAP	Any Zone Any Paper
B	Bels (applies to sound power level units)
B (A)	Bels (A weighted) (applies to sound power level units)
B (A) I	Bels (A weighted) Impulse response (applies to sound power level units)
BABT	British Approvals Board for Tele-Communication
BAM	Bundes Anstalt fur Materialprufung
BEUI	BIOS Extended User Interface
Bluetooth	Wireless local area network
BootP	Boot Protocol. AN IP protocol for automatically assigning IP addresses.
bps	Bits per second
BS	Behavior Specification
BT	Busy Tone
C	Celsius
CAT	Customer Admin Tool
CB	Certification Bodies
CCA	Cenelec Certification Agreement

Table 1

Term	Description
CCA	Customer Call Assistance
CCD	Charged Coupled Device
CCITT	Comite Consultatif International Telegraphique et Telephonique
CCR	Change Control Request
CD	Copy Darker. A copy density setting
CD-ROM	Compact Disk - Read Only Memory
CDDU	Controller and Drivers Delivery Unit
CDDUW	Controller and Drivers Delivery Unit - West Coast
CDS	Charge - deficient spot. A photoconductor defect that as a very small black spot (image quality parameter).
CED	Called Station Identification
CEH&S	Corporate Environmental Heath and Safety
CentreWare	CentreWare internet services is the embedded HTTP server application that is available on network enabled machines. It enables access to printing, faxing and scanning over the internet.
CFR	Confirmation To Receive
CISPR	Comite International Special des Perturbations
CID	Command Identification
CIG	Calling Subscriber Identification
CIS	Contact Image Sensor
CL	Copy Lighter. A copy density setting
Click Charge	Charge by copy/print rate
COD	Customer Operating Division
CPHI	Calls Per Hundred Installs
cpm	Copies per minute
CQ	Copy Quality
CR	Change Request
CRU	Customer Replaceable Unit
CRUM	Customer Replaceable Unit Monitor
CSE	Customer Service Engineer
CSF	Call Service Fault
CSMS	Customer Satisfaction Management System
Customer Drivers	Customer drivers are specially developed generally made with a driver toolkit. These drivers can provide a full set of features for Xerox printers. In the past, customers drivers have been provided for all major operating systems. A customer print driver is costly to develop, and does not used standard operating system components. For this reason, PPD / GPD solutions will be used in future whenever possible.
CTC	Continue To Correct
CTF	Contrast Transfer Function
CTR	Response For Continue To Correct
CTS	Clear To Send

Table 1

Term	Description
CVT	Constant Velocity Transport
CWW	CentreWare Web
DADF	Duplex Automatic Document Feeder (feeds documents to a different stack)
DADH	Duplex Automatic Document Handler (feeds documents to bottom of existing feed stack)
DB	Database
dB	Decibel (applies to sound pressure level units)
dB(A)	Decibels (A weighted) (applies to sound pressure level units)
dB(A)I	Decibels (A weighted) Impulse response (applies to sound pressure level units)
dC	Diagnostic code
DC	Digital Copier
DC	Device Controller, generic term for any module that acts as a image handling device e.g., SIP. Digital Copier
DC	Direct Current
DC + Fax	Digital Copier with embedded Fax card
DCN	Disconnect
DCS	Digital Command Signal
DDF	Device Description File
DHCP	Dynamic Host Config Protocol (similar to BootP)
DIMM	Dual In Line Memory Module
DIN	Deutsches Institute fur Normung
DLM	Dynamically Loadable Module
DMO-E	Developing Markets Operations East (was part of RX)
DMO-W	Developing Markets Operations West (was part of ACO)
DOS	Disk Operating Systems
DPHM	Defects Per Hundred Machines
DIS	Digital Identification Signal
DMA	Direct Memory Access
DMO	Developing Markets Operations
dpi	Dots per inch
DRAM	Dynamic Random Access Memory
DRS	Drum to Roll Spacing
DSR	Data Set Ready
DST	Daylight Saving Time
DT	Dial Tone
DTC	Digital Transmit Command
DTMF	Dual Tone Multiple Frequency
DU	Density Units
Dust Off	Routine to return machine to pre-install state

Table 1

Term	Description
EAA	Electron Auditor Administrator
EBS	Electronic Billing Service
EC	European Community
ECE	External Customer Engagement
ECM	Error Correction Mode. Electronic Counter Measure
EEC	European Economic Community
EET	Edge Enhancement Technology
EH&S	Environmental Health and Safety
ELOG	Electronic Log
EMC	Electromagnetic Compatibility
Embedded Fax	A fax system included in a system device
EME	Electromagnetic Emission
EN	European Norm
EOL	End Of Line
EOM	End Of Message
EOP	End Of Procedure
EOR	End Of Retransmission
EPA	Environmental Protection Agency
EPC	Electronic Page Collation (memory dedicated to temporary retention of images captured from the scanner and network controller)
EPROM	Erasable / Programmable Read Only Memory
EP-SV	Electronic Partnership Supervisor (kit)
EQM	Eye Quality Monitor
ERR	End Retransmission Response
ERU	Engineer Replaceable Unit
ESD	Electrostatic Discharge
ESG	European Solutions Group
ESS	Electronic Sub-System. For this machine use NC
ETP	Electronic Test Pattern
EU	European Union
EUR	Europe
FAX	Facsimile
FCC	Federal Communications Commission
FCD	Facsimile Coded Data
FCS	Facsimile Checking Sequence
FCOT	First Copy Out Time
FD	Functional Description
FEK	Feature Enablement Key
FER	Feature Enhancement Request
FID	Foreign Interface Device
FIF	Facsimile Information Field

Table 1

Term	Description
FIFO	First In First Out
FireWire	IEEE 1349. High speed serial communications system, comprising hardware plus protocol. Operates at 100, 200 or 400 Mbits/s, with 800 Mbits/s under development. See USB and RS-232
firmware	Software in a chip which cannot be altered
FLASH	On board erasable and reprogrammable non volatile memory
FOIP	FAX Over Internet Protocol
FPGA	Field Programmable Gate Array
FPOT	First Print Out Time
FRU	Fuser Replacement Unit
FSK	Frequency Shift Keying
FSMA	Field Service Maintenance Agreement
FTP	File Transfer Protocol
FTT	Failure To Train
FX	Fuji Xerox
G3	Group 3
GC	Group Command
GDI	Graphical Display Interface
GI	Group Identification
GLCD	Graphic Liquid Crystal Display
GND	Ground
GPD Minidrivers	A Generic Printer Description file has a function similar to PPD files. This format was developed by Microsoft to provide a simple method to develop drivers for non-postScript printers. Standard GPD minidrivers share the same lamentations as the PPD minidrivers, but they too can be enhanced using plug-ins. GPD Minidrivers are a new technology introduced for Windows 2000 and they will also be supported Windows NT 4. In Windows 95/98, a similar, but less powerful 'unidriver' format was used.
GS	German safety
gsm	Grams per square metre
GUI	Graphics User Interface
HC	High Capacity
HDD	Hard Disk Drive
HDLC	High Level Data Link Control
HFLN	High - Frequency (random) Line - Edge Noise. image quality metric.
HFSI	High Frequency Service Intervals
HLD	High Level Design. A document that defines the software high level design.
HTTP	Hyper Text Transfer Protocol
HUI	Hybrid User Interface
HVPS	High Voltage Power Supply

Table 1

Term	Description
Hz	Hertz
IB	InBoard
I2C-bus	Inter Integrated Circuit bus. This provides a simple bidirectional 2-wire bus for efficient inter-IC control. All I2C-bus compatible devices incorporate an interface which allows them to communicate directly with each other via the I2C-bus.
ICAT	Internal Customer Acceptance Test
ICE	Internal Customer Engagement
ID	Identification
IEC	International Electrotechnical Commission
IEE	Institute of Electrical Engineers
IEEE 1284	Parallel port communication
IETF	Internal Engineering Task Force
IFAX	Internet Fax
IIT	Image Input Terminal
IM	Interim Maintenance
Intlk	Interlock
IOT	Image Output Terminal
IOTC	Image Output Terminal Controller (IOT PWB, LVPS and HVPS). Sometimes referred to as the Power and Control Assembly.
IP	Internet Protocol
IPA	Image Processing Accelerator. Used by the machine scanning services to convert scanned images to a standard format e.g. for scan to file / scan to E-mail for network transmission.
IPM	Incremental Preventative Maintenance
IPM	Images per minute
IPP	Internet Printing Protocol
IPS	Image Processing Service
IPS1	Image Processing System
IPX	Internetwork Protocol eXchange
IQ	Image Quality
IR	Infra Red
ISDN	Integrated Services Digital Network / International Standard Data Network
ISIL	Inter and Side Image Lamp
ISO	International Standards Organisation
ITP	Internal Test Pattern
ITTCC	International Telegraph and Telephone Consultative Committee
ITU -T	International Telecommunications Union - Telecommunication
JBA	Job Based Accounting (Network Accounting)
JBIG	Joint Bi-Level Image Experts Group file interchange format
jitter	A line of missing or corrupted information in the fast scan direction.

Table 1

Term	Description
JPEG	Joint Photographic Experts Group file interchange format
kg	kilogram
kHz	kilohertz
Kill All	Routine to return all NVM, including protected NVM, to a virgin state. Factory use only
KO	Key Operator
LAA	Local Area Addressing
LAN	Local Area Network
LCD	Liquid Crystal Display
LCDM	Liquid Crystal Display Module
LCS	Line Conditioning Signal
LDAP	Lightweight Directory Access Protocol (allows sharing of corporate phone book information)
LE	Lead edge
LED	Light Emitting Diode
LEF	Long Edge Feed
LEISUS	Low End Interface Unsolicited Status-B
LG	Legal
LOA	Load Object Attributes
lpi	Lines per inch
LSI	Large Scale Integration
LT	Letter
LVPS	Low Voltage Power Supply
Lwr	Lower
LUI	Local user Interface
m	metre
MAC Address	Media Access Code. This is the basic, unique identifier of a networked device. An incoming message is analysed and an address in another form, such as an IP address, is resolved by a lookup table to a MAC address. The message is then directed to, and accepted by the equipment thus identified. It is the burnt-in, hardware address of a NIC.
MB	Megabyte (one MB = 1,048,576 bytes = 1024 kilobytes). Mail Box
Mb	Mega bit (one million bits)
MCB	Main Control Board
MCF	Message Confirmation
MF	Multifunction
MFLEN	Mid - Frequency (random) Lines - Edge Noise
MH	Modified Huffman
MIB	Machine Information Block. SNMP database element
MJ	Modular Jack
mm	millimetre
MMC	Microsoft Management Console

Table 1

Term	Description
MMR	Modified Modified Read compression
MN	Multi - National
Modem	MODulator/DEModulator. Hardware unit that converts the 'one' and 'zero' binary values from the computer to two frequencies for transmission over the public telephone network (modulation). It also converts the two frequencies received from the telephone network to the binary values for the computer (demodulation).
Moire	Image quality defect caused by interference between patterned originals and the digital imaging process. Moire patterns are repetitive and visible as bands, plaids or other texture.
MPS	Multi-Page Signal
MR	Modified Read compression
MRD	Machine Resident Diskette
MRC	Modified Read Compression
MSG	Management Steering Group
ms	millisecond
MSI	Multi-Sheet Inserter
MSO	Mixed Size Originals
MSOK	Master System Option Key
MMSOK	Manufacturing Master System Option Key
MX	Modi Xerox
N	Newton
NASG-N	North American Solutions Group (equivalent to XCI)
NASG-S	North American Solutions Group (equivalent to USCO)
nC	nanoCoulomb
NC	Network Controller (equivalent to ESS).
NC	Normal Contrast. Copy contrast setting
NCR	No Copying Required
NCU	Network Control Unit
NDS	NetWare Domain Services or Novell Directory Services
NDS Context	NetWare Domain Services Context
NDS Tree	NetWare Domain Services Tree
NetBEUI	NetBIOS Extended User Interface. A network device driver or transport protocol that is the transport driver supplied with LAN Manager. It can bind with as many as eight media access control drivers.
NetBIOS	Network Basic Input / Output System. Software developed by IBM that provides the interface between the PC operating system, the I?O bus, and the network. Since its design, NetBIOS has become a de facto standard.
NGI	Next Generation Infrastructure (new files and mail servers)
NIC	Network Interface Card. Converts the data to a form suitable for transmission and reception. Uses ARP and RARP.
Nm	Newton metre

Table 1

Term	Description
NOHAD	Noise, Ozone, Heat, Airflow and Dust
NP	Printer configuration
NS	Normal Sharpness. Copy sharpness setting
NSC	Non-Standard Facilities Command
NSF	Non-Standard Facilities
NSS	Non-Standard Set-Up
NSSD	Network. The SESS and CentreWare development team based in Rochester NY. This group is now named CDDU.
NVM	Non-Volatile Memory
OA	Open Architecture
OB	Out Board
OEM	Original Equipment Manufacturer
OGM	On Going Maintenance
OpCo	Operating Company
OSA	Online support Assistant
OSCG	Office Systems Component Group
OSOK	Optional System Option Key
P/R	Photoreceptor
PABX	Private Automatic Branch Exchange
PC	Personal Computer
PC Fax	Personal Computer Fax
PCI	Peripheral Component Interface
PCI	Personal Computer Interface
PCL	Printer Control Language
PCMCIA	Personal Computer Memory Card International Association
PD	Process Direction
PDF	Adobe Acrobat Portable Document Format
PDL	Page Description Language
PDT	Product Delivery Team
PEK	Product Enablement Key
Pels	Picture Data (Pixel)
PFM	Paper Feed Module
PHI	per Hundred Installs
PIN	Procedural Interrupt Negative
PIN	Personal Identification Number
ping	Packet InterNet Groper. Tool to test connections between nodes by sending and returning test data.
PIP	Procedural Interrupt Positive
PJL	Printed Job Language. Hewlett Packard page description language.
PMC	Programme Management Committee
POPO	Power Off Power On

Table 1

Term	Description
POO or P of O	Principles of Operation
POST	Power On Self Test
PPC	Power PC. A EPROM manufacturer
PPD	Postscript Printer Description. A PPD file is a simple formatted text file that contains a description of the printers features and the corresponding PostScript 'code' needed to activate each feature. Apple LaserWrite drivers and application programs such as Adobe PageMaker can use PPD files. With a OOD file, many of the printing features of a network printer can be made available to users. However advanced features such as LAN Fax, Accounting and Exception Page Programming cannot be provided.
PPD Minidrivers	PPD minidrivers are available in Windows operating systems (from Windows 95 onwards). With these, a Xerox - supplied PPD file is used in conjunction with an operating system supplied driver to create a PostScript driver tailored for a specific device. In windows 95/98, a driver provided by this method has lamentations and not all devices features can be made available to the user. With Windows NT 4 and Windows 2000, it is possible to make more features available by using a user interface rendering plug - in. In this document, if the driver is to be provided with If no plug-ins are provided, then it is called a standard minidriver.
PPHI	Problems Per Hundred Installs
ppm	Prints per minute / Parts Per Million
PPR	Partial page Request
pps	Partial Page Signal / pulses per second
PPS	Product Performance Specification
PR	Photo-Receptor
PRI-EOM	Procedure Interrupt-EOM
PRI-EOP	Procedure Interrupt-EOP
PRI-MPS	Procedure Interrupt-MPS
PSM1	Power Save Mode 1 (low power mode)
PSM 3	Power Save Mode 3 (sleep mode)
PS	Post Script
PSTN	Private Switched Telephone Network
PSW	Portable Service Workstation
PTT	Post, Telephone, Telegraph (national public utilities)
PVC	Poly Vinyl Chloride
PVT	Product Verification Test
PWB	Printed Wiring Board
PWS	Portable Work Station
QIT	Quality Improvement Team
RAM	Random Access Memory

Table 1

Term	Description
RARP	Reverse Address Resolution. Reverse of ARP. Converts a MAC address to an IP address. The document centre resolves its address using RARP. See also MAC, NIC and ARP.
RBT	Ring Back Tone
RCA	Remote Customer Assistance
RDT	Remote Data Transfer
R/E	Reduction / Enlargement
REN	Ringer Equivalence Number
RFC	Request for comment. An IETF standard reference.
ROHS	Restriction of Hazardous Substances
RPC	Remote Procedure Call
RH	Relative humidity
RIC	Remote Interactive Communications
RIS	Raster Input Scanner
Riser PWB	A card that increases the number of PCI slots.
RJ 45	Phone type network connector
RM	Requirements Management
RMS	Root Mean Square (AC value)
RNR	Receive Not Ready
RO	Regional Operations
ROS	Raster Output Scanner
RR	Receive Ready
RRB	Requirements Review Board
RS-232, RS-423, RS-422, RS-485	Series of standards for serial communication of data by wire. RS-232 operates at 20 kbits/s, RS-423 operates at 100 kbits/s, RS-422 and RS-485 operate at 10 Mbits / s. See FireWire and USB.
RTN	Retrain Negative
RTP	Retrain Positive
RTS	Request To Send
Rx	Receive
SA	Systems Administration
SAD	Solid Area Density
SAF	Safety
SAKO	Systems Administration Key Operator
SAP	Service Advertising Protocol. a network device will broadcast its capabilities onto the network at a defined intervals.
SAP	Service Advertising Protocol
SAR	Semi-Active Retard feeder
SCD	Software Compatibility Database
SCF	Second Cassette Feeder
SCM	Software Configuration Management

Table 1

Term	Description
SCN	Specification Change Notice
SCR	Software Change Request
SCSI	Small computer Systems Interface
SCT	Simple Catch Tray
S/D	Shut Down
SDK	Software Development Kit
SDP	Software Development Plan
SDR	Shut Down Rate
SDRAM	Synchronous Dynamic Remote Access Memory
Server Fax	A fax system that uses a remote Fax server. Faxes transmit as a Scan to File job sent to the server. Fax receive as print jobs submitted to the Connection Device.
SEF	Short Edge Feed
SESS	Strategic Electronic Sub-System
SFO	Special Feature Option
SIM	Scanner Input Module
SIP	Scanning and Image Processing
SIR	Standard Image Reduction
Sixth Sense	A single device and group management tool
SLP	Service Location Protocol (finds servers)
SM	Scheduled Maintenance
SMB	Server Message Block. Microsoft Server / Client Communications protocol
SMP1	Service Maintenance Pack 1 (contains a software package)
SPAR	Software Problem Action Request
SNMP	Simple Network Management Protocol
Snr	Sensor
SOD	System Operating Description
SPL	Sound Pressure Level
SPP	Short Paper Path
spi	Spots per inch
SPID	Service Profile Identification
SQA	Software Quality Assurance
SR	Service Representative
SRAM	Static Random Access Memory
SRC	Software Requirements
SS or S/S	Sub System
ST	System Terminal Device. Multi-functional device as defined by Energy Star (includes DC / NC and DC / NC / Fax)
STP	Standard Test Pattern
SW	Switch

Table 1

Term	Description
SW or S/W	Software
SWL	Sound Power Level
system kernel	Minimal operating system
T & M	Time and Materials
TAR	Take away Roll
TBC	To Be Confirmed
TBD	To Be Defined
TCP / IP	Transmission Control Protocol / Internet Protocol
TE	Trail Edge
Template	A collection of Scan to File attributes that can be conveniently re-used.
TC	Toner Concentration
TCF	Training Check Field
TEI	Terminal Endpoint Identifier
TIFF	Tagged Image File Format
TIFF FX	TIFF Fax eXtended
TIFFX	Tagged Image File Format - for internet FAX
TP	Test Point
TPM	Technical Programme Manager
Transmissive LCD	Liquid Crystal Display lit from the back
TRC	Toner Reproduction Curve
TRN	Train
TSH	Technical Service Hours
TSI	Transmit Subscriber Identification
TTY	Teletype Terminal
TUI	Textual User Interface
Tx	Transmit
UGD	An upgrade file, i.e. filename.ugd
UART	Universal Asynchronous Receiver Transmitter
UDP	User Datagram Protocol
UI	User Interface (display screen)
UK	United Kingdom
UM	Unscheduled Maintenance
UMR	Unscheduled Maintenance Rate
URL	Universal Resource Locator
USB	Universal Serial Bus. High speed successor to parallel port for local device communications. Operates at 12 Mbits / s. See FireWire and RS-232.
USCO	United States Customer Operations
UTP	Unsheilded Twisted Pair
V.17 / V.29 / V.34	Modem standards
VALO	Value Added Logistic Organisation

Table 1

Term	Description
VAR	Value Added Reseller
VDE	Verband Deutscher Elektrotechniker
VGA	Video Graphics Array
VOIP	Voice Over Internet Protocol
WC	WorkCentre
WC + PS	WorkCentre + PostScript print drivers
WEB UI	CentreWare Internet Services
WINS	Window Internet Name Service
XAP	Xerox Asia Pacific
XC	Xerox Canada
XCMI	Xerox Common Management Interface
XE	Xerox Europe
XI	Xerox Initiated
XL	Xerox Limited
XLA	Xerox Latin America
XOG	Xerox Office Group
XRU	Xerographic Replacement Unit
XSA	Xerox Standard Accounting
XUL	Xerox Unique Login enables use of the xerox corporate directory

## GP 15 Shading Test

Use this procedure to test the CCD. If the image quality is unsatisfactory, perform this procedure to check the operation of the CCD.

### Procedure

**NOTE:** Before performing the adjust shading test, ensure the DADF is lowered.

Perform the following:

1. Enter diagnostics, GP 1 or System Administration Tools, GP 4.
2. Select **Shading Test**.
3. Select **Shade and Print Report** or **Print Last Shade Report**.
4. The shading test profile will be printed when diagnostics or system administration tools are exited, Figure 1.
5. Check the shading test profile. The result of the test will be printed at the bottom of the page. If the result of the test is 'OK', the CCD is good.

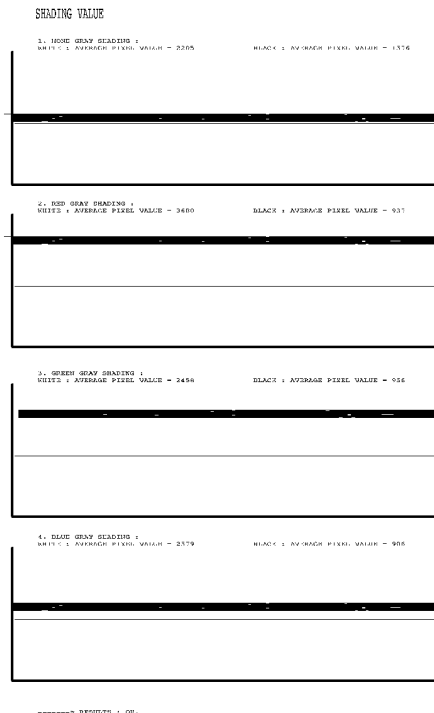

Figure 1 Shading profile

AP-1-1522-A

## GP 16 High Frequency Service Items

### Purpose

To provide the service engineer with a method to view the service history of the high frequency service items (HFSI). The service engineer can reset the counters and change the setting of the maximum life and threshold value of each HFSI item.

### Procedure

Enter diagnostics GP 1. Select the Service Info window and touch the HFSI feature to select the HFSI table.

The five columns in the HFSI table on the display screen are:

- The Item column, shows the HFSI item to be tracked.
- The Status column, indicates the status of an item relative to its threshold setting. Values are "Off" (not tracked), "OK" or "Check".
- The Unit column, shows the events that are being used to track the item.
- The Actual column, shows the actual count value against the HFSI item.
- The Max. Life column, shows the maximum life count value of the HFSI item.

The Actual and Maximum Life count value have a numeric range of 0 to 9999999 for all HFSI items.

The first item in the HFSI table will be the item that requires attention (if needed) then the item will be displayed as "Check". If the item has not yet reached threshold the "OK" is displayed.

To change the maximum life or threshold value of each HFSI item, perform the following:

1. Select and highlight the HFSI item to change.
2. Touch the Edit button.
3. Enter the new value using the numeric keypad. The new value will overwrite the existing value in the table. Touch the Save button to enter the new maximum life or threshold value into the file. If the entered value is incorrect, press the Undo button. This stops the process and the old value is retained.

A threshold value of zero indicates that there is no threshold value assigned to the item and the status will be "Off" (not tracked).

The maximum life setting and the threshold settings are independent of each other. The threshold value can exceed the maximum life value.

To reset the HFSI item Actual count value to zero, perform the following:

1. Select and highlight the HFSI item to reset.
2. Touch the Reset button,
3. Touch the OK button to reset the count value to zero.

For details of high frequency service items, refer to SCP 5 Subsystem Maintenance.

## GP 17 Restriction of Hazardous Substances (RoHS)

### Purpose

To give information on the RoHS Directive.

The RoHS Directive restricts the use of certain hazardous substances in electrical and electronic equipment. It applies to equipment placed in the European Union (EU) market. The directive takes effect from 1st July 2006.

**NOTE:** *Currently these restrictions are only for the European Union (EU) market and some associated countries. For more information go to [www.Xerox.com](http://www.Xerox.com).*

The hazardous substances are:

- Lead (Pb)
- Mercury (Hg)
- Cadmium (Cd)
- Hexavalent Chromium (Cr 6+, Cr [VI])
- Polybrominated Diphenyl Ethers (PBDE's)
- Polybrominated Biphenyls (PBB's)

### Identification of a RoHS Compliant Machine

Xerox will maintain a central list of RoHS compliant machines.

This general procedure is for information only. All Phaser 3635MFP machines are RoHS compliant.

## GP 18 Scan Edge

Use this procedure to test the document edge detection routine.

### Procedure

**NOTE:** *Before performing the scan edge print, ensure the DADF is lowered.*

Perform the following:

1. Enter diagnostics, GP 1.
2. Select **Diagnostic Routines**.
3. Select **Other Routines**.
4. Select **Scan Edge**.
5. Select **Print**. The scan edge print will be printed.
6. If the following co-ordinates are displayed, the scan edge print is good:  
Valid Image [ 0: 96] [ 0: 108]  
Scan Image [ 0: 384] [ 0: 432]

## dC001 Reset Auditron Master PIN

### Purpose

To reset the Auditron and the System Administration password to the default, (1111).

**NOTE:** The Auditron and the System Administration password is the same item.

### Procedure

1. Enter diagnostics, GP 1.
2. Select **Diagnostic Routines**, then select **Other Routines**, then select **001 Reset Auditron Master PIN**.
3. Select **Reset Auditron Master PIN**.
4. Select confirm or cancel.

## dC109 Embedded Fax Protocol Report

### Purpose

This procedure allows the CSE to print out the Fax protocol report. The protocol report contains the protocol information about the last fax transmissions. The protocol report contains the following:

- Date and time.
- The Fax number and Fax name.
- Machine firmware versions.
- The communication summary with the time and a FCF column. The FCF column will display abbreviations, refer to Table 1.

### Procedure

1. Enter diagnostics, GP 1.
2. Select **Diagnostic Routines**.
3. Select **Fax dC Routines**, then select **109 Protocol Report**.
4. Select **Print**.
5. The Print Report button greys out until the job has been submitted. The Fax card builds the protocol report job and places the job in the Fax NVM. This is the equivalent of an active Fax job in the Fax card queue.
6. The protocol report prints out.

### Analyse the Fax Protocol Report.

For an example of a Fax protocol report, refer to Figure 1.

- The time column records the time at which each event occurs, from the start of the communication.
- The S/R column shows if the Fax job was sent or received.
- The FCF data column contains information regarding the type of information being exchanged.
- The FIF column providing a Hex value of the data information contained in the G3 facsimile information field.

If the protocol report shows a fault and go to the 20-100 to 20-900 Fax Faults RAP. if the protocol report does not show a fault, go to the 20A Fax Faults Without a Code RAP.

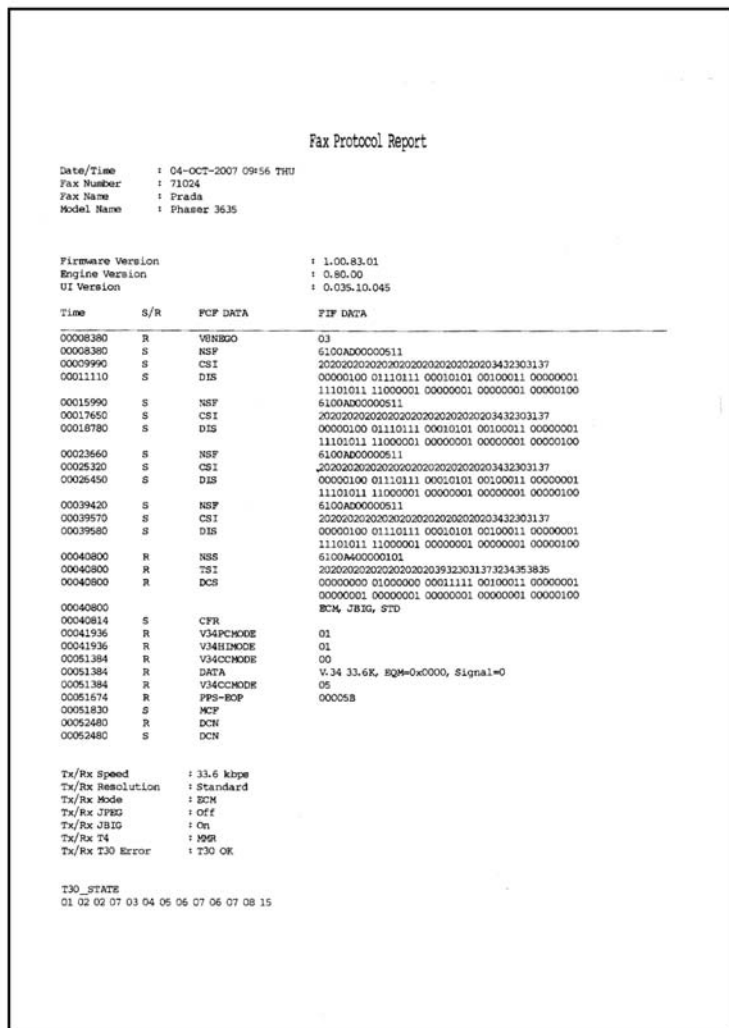

Figure 1 Fax protocol report

Table 1 Abbreviations

Term	Description
ANSam	Modulated answer tone
CED	Called terminal identification
CFR	Confirmation to receive
CI	Call indicator

Table 1 Abbreviations

Term	Description
CIG	Calling subscriber indentation
CJ	CM terminator
CM	Call menu
CNG	Calling tone
CRP	Command repeat
CSI	Called subscriber identified
CTC	Continue to correct
CTR	Response for continue to correct
DCN	Disconnect
DCS	Digital command signal
DIS	Digital identification signal
DTC	Digital transmit command
EOM	End of message
EOP	End of procedure
EOR	End of retransmission
ERR	Response for end of transmission
FCF	Facsimile control field
FIF	Facsimile information field
FTT	Failure to train
JM	Joint menu
MCF	Message confirmation
MPS	Multi page signal
NSC	Non to standard facilities command
NSF	Non to standard facilities
NSS	Non to standard setup
PID	Procedure interrupt
PIN	Procedure interrupt negative
PIP	Procedure interrupt positive
PPS	Partial page signal
PPR	Partial page request
PRI-EOM	Procedure interrupt to EOM
PRI-EOP	Procedure interrupt to EOP
PRI-MPS	Procedure interrupt to MPS
PWD	Password for (polling)
PWD	Password for (transmission)
RCP	Return to control for partial page
RNR	Receive not ready
RR	Receive ready
RTN	Retrain negative
RTP	Retrain positive
SEP	Selective polling

Table 1 Abbreviations

Term	Description
SUB	Subaddress
TCF	Training check
TSI	Transmitting subscriber identification

## dC131 NVM Read/Write

### Purpose

To review and modify values within the machine configuration and control parameters stored in NVM.

### Description

Each NVM item is identified using a chain and location code in the form XX-XXX, where XX- is the chain prefix, and -XXX is an identifier in the range 001 to 999. For example 05-100.

### Procedure

1. Enter diagnostics, GP 1.
2. Select **Diagnostic Routines**.
3. Select the required dC routine category:
  - **Copier Routines.**
  - **Fax dC Routines.**
4. Select **131 NVM Read/Write**.
5. Select the appropriate button for the NVM chain to be viewed.
6. Use the scroll buttons to view the other NVM locations of the chain.
  - Use the keyboard to type the three digit identifier code into the Find: field and then touch the Find: button. This puts the found NVM value at the top of the list.

**NOTE:** Press the keypad C button to reset the Find: button to 000.
7. Touch the selected NVM in the list, and touch the Read/Write button.
  - The Read/Write window will open for editable NVM, and the Read Only window will open for Read Only (protected) NVM.
8. Refer to the tables that follow for NVM chain locations and parameters:
  - Table 1 NVM chain 6
  - Table 2 NVM chain 7
  - Table 3 NVM chain 9
  - Table 4 NVM chain 10
  - Table 5 NVM chain 20
9. When the values of an editable NVM have been changed, switch off the machine, then switch on the machine, to check and evaluate the changes made to the NVM.

**NOTE:** If the NVM default characters exceed 10 characters only the first eight characters are displayed in the list. The full string is displayed in the Read/Write window.

**NOTE:** Selecting Reset will cause the selected NVM location to be reset to its default value. Selecting Cancel closes the window and cancels any changes made in the now closed window.

**NOTE:** The CSE cannot read or modify any NVM that contains customer administrative or accounting data.

**NOTE:** The Read Only (protected) NVM can only be changed using a password obtained from Xerox.

**Table 1 NVM chain 6**

Location	NVM Name	NVM Description	Value	Default
06-100	Vertical Magnitude	The changed dimension of the vertical direction magnitude.	0mm to 6mm (12 steps / 0.5mm seg.)	3
06-110	Horizontal Magnitude	The changed dimension of the horizontal direction magnitude.	0mm to 6mm (12 steps / 0.5mm seg.)	3

**Table 2 NVM chain 7**

Location	NVM Name	NVM Description	Value	Default
07-100	Top Registration Tray 1 Simplex	The changed dimension of tray 1 top registration in simplex.	0mm to 6mm (12 steps / 0.5mm seg.)	3
07-110	Side Registration Tray 1 Simplex	The changed dimension of tray 1 side registration in simplex.	0mm to 6mm (12 steps / 0.5mm seg.)	3
07-120	Top Registration Tray 1 Dup_long (2nd side)	The changed dimension of tray 1 top registration of 2nd side in duplex long.	0mm to 6mm (12 steps / 0.5mm seg.)	3
07-130	Side Registration Tray 1 Dup_long (2nd side)	The changed dimension of tray 1 side registration of 2nd side in duplex long.	0mm to 6mm (12 steps / 0.5mm seg.)	3
07-140	Top Registration Tray 1 Duplex (1st side)	The changed dimension of tray 1 top registration of 1st side in duplex long and short.	0mm to 6mm (12 steps / 0.5mm seg.)	3
07-150	Side Registration Tray 1 Duplex (1st side)	The changed dimension of tray 1 side registration of 1st side in duplex long and short.	0mm to 6mm (12 steps / 0.5mm seg.)	3
07-200	Top Registration Tray 2 Simplex	The changed dimension of tray 2 top registration in simplex.	0mm to 6mm (12 steps / 0.5mm seg.)	3
07-210	Side Registration Tray 2 Simplex	The changed dimension of tray 2 side registration in simplex.	0mm to 6mm (12 steps / 0.5mm seg.)	3

**Table 2 NVM chain 7**

Location	NVM Name	NVM Description	Value	Default
07-220	Top Registration Tray 2 Dup_long (2nd side)	The changed dimension of tray 2 top registration of 2nd side in duplex long.	0mm to 6mm (12 steps / 0.5mm seg.)	3
07-230	Side Registration Tray 2 Dup_long (2nd side)	The changed dimension of tray 2 side registration of 2nd side in duplex long.	0mm to 6mm (12 steps / 0.5mm seg.)	3
07-240	Top Registration Tray 2 Duplex (1st side)	The changed dimension of tray 2 top registration of 1st side in duplex long and short.	0mm to 6mm (12 steps / 0.5mm seg.)	3
07-250	Side Registration Tray 2 Duplex (1st side)	The changed dimension of tray 2 side registration of 1st side in duplex long and short.	0mm to 6mm (12 steps / 0.5mm seg.)	3
07-500	Top Registration Bypass Simplex	The changed dimension of bypass top registration in simplex.	0mm to 6mm (12 steps / 0.5mm seg.)	3
07-510	Side Registration Bypass Simplex	The changed dimension of bypass side registration in simplex.	0mm to 6mm (12 steps / 0.5mm seg.)	3
07-520	Top Registration Bypass Dup_long (2nd side)	The changed dimension of bypass top registration of 2nd side in duplex long.	0mm to 6mm (12 steps / 0.5mm seg.)	3
07-530	Side Registration Bypass Dup_long (2nd side)	The changed dimension of bypass side registration of 2nd side in duplex long.	0mm to 6mm (12 steps / 0.5mm seg.)	3
07-540	Top Registration Bypass Duplex (1st side)	The changed dimension of bypass top registration of 1st side in duplex long and short.	0mm to 6mm (12 steps / 0.5mm seg.)	3
07-550	Side Registration Bypass Duplex (1st side)	The changed dimension of bypass side registration of 1st side in duplex long and short.	0mm to 6mm (12 steps / 0.5mm seg.)	3

**Table 3 NVM chain 9**

Location	NVM Name	NVM Description	Value	Default
09-100	LD Light Level	600dpi laser light level. Value in PWM.	200 to 600	350
09-110	MHV Control Bias Control	Main charge bias control. Basic of value (HVPS setting is value). Value in PWM.	108 to 145	126
09-120	THV Bias Control Control	Transfer bias control. Basic of value (HVPS setting is value). Value in PWM.	41 to 220	76
09-130	Deve Bias Control	DEVE bias control. Basic of value (HVPS setting is value). Value in PWM standard voltage: --500V (PWM 522).	408 to 607	522

**Table 3 NVM chain 9**

Location	NVM Name	NVM Description	Value	Default
09-140	Detack Bias Control	Detack bias control. Basic of value (HVPS setting is value). Value in PWM standard voltage: -1800V.	80 to 160	123
09-205	Print Cartridge Life Page Counter	Display of print cartridge pages count.	(Read only)	
09-230	Transfer Roller Life Page Counter	Display value of pages count.	(Read only)	

**Table 4 NVM chain 10**

Location	NVM Name	NVM Description	Value	Default
10-200	Fuser Life Page Counter	(Read only) Total fuser page count		
10-210	Heat Roll Life Page Counter	(Read only) Heat roll page count		
10-220	Pressure Roll Life Page Counter	(Read only) Pressure roll page count		
10-300	Pick-up Interval Delay	Change the time interval for paper pick-up.	0 to 100 msec.	0
10-310	Pick-up Interval Delay (Special Paper)	Change the time interval for paper pick-up.	0 to 100 msec.	0

**Table 5 NVM chain 20**

Location	NVM Name	NVM Description	Value	Default
20-100	Redial Attempts	Number of times to redial.	1 to 13	7
20-110	Redial Interval	Time between each redial.	1 to 15	3
20-200	Pause Dial Time	Time of each pause.	0 to 200 (1000 msec.)	4
20-210	Dial Pulse M/B Ratio	Dial pulse make/break ratio.	33/66 (0) 40/60 (1)	1
20-220	Auto Dial Start Pause Time	Pause time before auto-dialing (second)	0 to 10 seconds	1
20-300	Ring On Time	Ring on time.	90 to 800msec.	90
20-310	Ring Off Time	Ring off time.	90 to 800msec.	90
20-320	Ring Detection Freq	Call indication frequency range.	12 to 80Hz (1) 16 to 55Hz (2) 20 to 55hz (3) 22 to 55hz (4)	1
20-400	DTMF High-Freq Level	DTMF high frequency level.	0 to 15dBm	8
20-410	DTMF Low-Freq Level	DTMF low frequency level.	0 to 15dBm	11

**Table 5 NVM chain 20**

Location	NVM Name	NVM Description	Value	Default
20-420	DTMF Timing	DTMF duration of on/off output.	80/80 (1) 70/70 (2) 70/150 (3) 60/60 (4) 80/100 (5) 150/50 (6) 150/240 (7)	1
20-500	Dial Mode	Dial mode selection.	Tone (0) / Pulse (1)	0
20-510	ECM Mode	ECM mode on or off.	Off (0) On (1)	0
20-520	Error Rate	Adjusts the error rate.	Off (0) / 5% (1) / 10% (2) / 20% (3)	0
20-530	Dial Tone Detect	Detects dial tone prior to sending.	Off (0) On (1)	0
20-540	Loop Current Detect	Detects if loop current is present prior to sending.	Off (0) On (1)	0
20-550	Busy Signal Detect	Detects a busy signal to allow redials.	Off (0) On (1)	0
20-700	Line Monitor Setting	Audio line monitor.	Off (0) On (1) Comm (2)	0
20-800	Modem Speed	Select modem start speed.	Modem_V21_300bps (0) Modem_V27_2400bps (1) Modem_V27_4800bps (2) Modem_V29_7200bps (3) Modem_V29_9600bps (4) Modem_V33_12000bps (5) Modem_V33_14400bps (6) Modem_V17_7200bps (7) Modem_V17_9600bps (8) Modem_V17_12000bps (9) Modem_V17_14400bps (10) Modem_V34_2400bps (11) Modem_V34_4800bps (12) Modem_V34_7200bps (13) Modem_V34_9600bps (14) Modem_V34_12000bps (15) Modem_V34_14400bps (16) Modem_V34_16800bps (17) Modem_V34_19200bps (18) Modem_V34_21600bps (19) Modem_V34_24000bps (20) Modem_V34_26400bps (21) Modem_V34_28800bps (22) Modem_V34_31200bps (23) Modem_V34_33600bps (24)	0

Table 5 NVM chain 20

Location	NVM Name	NVM Description	Value	Default
20-810	Fax Transmis- sion Level	Adjusts the fax transmis- sion level	0 to 15dBm	12
20-830	Auto Dial Time- out	Adjusts the auto dial tim- eout	10 to 100 seconds	55
20-840	FAX Batch Send Enable	Fax batch send enable	Off (0) On (1)	0
20-900	FAX Total Send Counter	Total of sent fax pages.	0-0xffffffff	0
20-910	FAX Total Receive Counter	Total of received fax pages.	0-0xffffffff	0

## dC132 NVM Initialization

Refer to the relevant section:

- NVM Initialization - Copier
- NVM Initialization - Network
- NVM Initialization - Fax Card

### NVM Initialization - Copier

#### Purpose

To return the copier NVM settings to default. Refer to dC131.

#### Procedure

1. Enter diagnostics, GP 1.
2. Select **Diagnostic Routines**.
3. Select **Copier Routines**, then **132 NVM Initialization - Copier**.
4. Touch the appropriate button to select the NVM to be initialized and follow the screen instructions. Refer to Table 1, for the functions that are reset to default:
  - All Copier NVM
  - Machine Variable NVM
  - SA/KO Dust Off
  - System Counters Dust Off
5. Switch off the machine, then switch on the machine.

Table 1 Copier NVM

Copier file type Category	All Copier NVM	Machine Variable NVM	SA/KO Dust Off	System Counters Dust Off
NVM System Usage Counter	Y			Y
NVM Fault Counter	Y			Y
NVM Diag Counter	Y			Y
NVM SAKO Setting	Y		Y	
NVM Fault Log	Y			
NVM Configuration	Y			
NVM Diagnostics	Y			
NVM Debug	Y			
NVM Mach Var	Y	Y		
NVM Mach Var Zero	Y	Y		
NVM Mach Var Registration	Y	Y		
NVM Mach Var Paper Path	Y	Y		
NVM Mach Var DADF	Y	Y		
NVM Mach Var Platen	Y	Y		
NVM Auditron	Y		Y	
NVM Crash Recovery	Y			
NVM Completed Job Log	Y			

**Table 1 Copier NVM**

Copier file type Category	All Copier NVM	Machine Variable NVM	SA/KO Dust Off	System Counters Dust Off
NVM JBA Database	Y		Y	
NVM JBA Config	Y		Y	
NVM Auditron Config	Y		Y	
NVM HFSI Counter	N	N	N	N

**NVM Initialization - Network**

**Purpose**

To reset the network settings to default.

**Procedure**

1. Enter diagnostics, GP 1.
2. Select **Diagnostic Routines**.
3. Select **Network Routines, 132 NVM Initialization - Network**, then **All Network NVM**.
4. Follow the screen instructions to reset the network settings.
5. Switch off the machine, then switch on the machine.

**NVM Initialization - Fax Card**

**Purpose**

To return the fax card NVM settings to default. Refer to dC131.

**Procedure**

1. Enter diagnostics, GP 1.
2. Select **Diagnostic Routines**.
3. Select **Fax dC Routines**, then **132 NVM initialisation**.
4. Touch the appropriate button to select the NVM to be initialized and follow the screen instructions. Refer to Table 2, for the functions that are reset to default.
  - Kill All
  - All Fax Directories
  - Fax Job NVM
  - Fax Configuration NVM
  - Fax SA/KO Settings NVM
5. Switch off the machine, then switch on the machine.

**Table 2 Fax NVM**

Fax file type Category	Kill All	All Fax Directories	Fax Job NVM	Fax Configuration NVM	Fax SA/KO Settings NVM
Mailbox Directories	Y	Y			
Poll Directories	Y	Y			
Job Sets	Y		Y		
Jobs	Y		Y		
Image	Y		Y		
Bitmaps	Y		Y		
Job ID	Y		Y		
Mailbox	Y		Y		
Alarm	Y		Y		
Fax Protocol Trace	Y		Y		
Protocol Records	Y		Y		
Container Versions	Y				
FAX NVM Configuration				Y	
Fax NVM SA/KO Settings					Y

**Table 2 Fax NVM**

Fax file type Category	Kill All	All Fax Directories	Fax Job NVM	Fax Configuration NVM	Fax SA/KO Settings NVM
Dial Directories	Y	Y			
Group Directories	Y	Y			
Junk Directories	Y	Y			
Logo Directories	Y	Y			

## dC305 UI Test

### Purpose

To initiate component testing of the local UI. This function also provides a means to test the UI memory and to restart the local UI.

### Description

Refer to GP 12 User Interface Tests Description.

### Procedure

1. Enter diagnostics, GP 1.
2. Select, **Diagnostics Routines, Copier Routines, dC305 UI Tests.**
3. Touch the appropriate test button.
4. Touch Start Test and follow the on-screen instructions.

## dC330 Component Control

### Purpose

To show the status of input components e.g. sensors, and to energize output components e.g. motors, solenoids.

### Description

Output and input component codes are entered into the Component Control Table on the UI, and then energized individually or in permitted groups. The codes in the tables are grouped in similar functional behaviour.

Go to the appropriate procedure:

- Input Components
- Output Components

### Input Components

When the appropriate code is entered the status of the component will be shown on the UI.

**NOTE:** *The actual signal as measured with a service meter will not necessarily be the same as the logic state shown on the UI, especially where the output is inverted. When testing components using these control codes, look for a change in state, not for a high or low.*

The displayed status of the input component can be changed by causing the component status to change, e.g. operating a sensor with a sheet of paper. When a sensor is operated a beep will sound.

Go to the appropriate table:

- Table 1 Input Codes 01
- Table 2 Input Codes 05
- Table 3 Input Codes 06
- Table 4 Input Codes 07
- Table 5 Input Codes 08
- Table 6 Input Codes 09
- Table 7 Input Codes 10

### Output Components

When the appropriate code is entered, the component will energize for a set time and then stop in order to protect the components. The default time-out for all components is shown. Some components require that other components are energized at the same time and it is possible to enter and energize up to six component control codes (not fax), but only in permitted groups. If illegal combination of codes are entered the illegal codes will not energize.

Go to the appropriate table:

- Table 8 Output Codes 04
- Table 9 Output Codes 05
- Table 10 Output Codes 06
- Table 11 Output Codes 08
- Table 12 Output Codes 09
- Table 13 Output Codes 10
- Table 14 Output Codes 20

## Procedure

1. Enter Diagnostics, GP 1.
2. Select **Diagnostics Routines**.
3. Select required dC routine category:
  - Copier Routines, 330 Component Control.
  - Fax dC Routines, 330 Component Control.
4. Select and input the required codes as follows:

**NOTE:** To clear an incorrectly entered code and reset the Add Component button to 00.000, press the hard key C.

- a. From the component control Input Codes tables and the Output Codes tables, select and enter the appropriate code into the Add Component button, and touch the button. This will add the component to the top of the Component Name table list. When the list is full, the addition of more components will cause components to be deleted from the bottom of the list.

**NOTE:** Fax component control codes can only be energized one at a time.

- b. If a control code is not known, it can be selected from the list displayed when the Find Component button is touched, as follows:

**NOTE:** The 'Find Component' button is not available if components are energized.

- i. Enter the chain number into the Chain: button and touch the Find Component button to display the control codes for that chain.
  - ii. Use the scroll buttons to locate the required code, touch the Component Name button to highlight it and touch Select.
  - iii. Repeat as required to add components to the Component Name table.
  - iv. Touch Save to save the selections to the Component Name table list and return to the Component Control window.
5. To energize a component or group of components:
    - a. Touch the control code to highlight it.
    - b. Touch Start.
    - c. The status of the component is shown in the Status column i.e.:
      - i. On
      - ii. Off
      - iii. High
      - iv. Low
      - v. A numeric value with up to four digits e.g. 0020.
  6. Touch a component in the component table and then touch Stop to stop that component. To stop all components touch Stop All.
  7. Touch Exit to close the Component Control window.
  8. To exit diagnostics mode, GP 1, select the Call Close Out button.

## Input Codes

**Table 1 Input codes 01**

Code	Displayed Name	Description	General
01-100	Front cover interlock	Front cover interlock switch (S01-100), detects if the side cover is open.	Closed = front cover closed Opened = front cover opened

**Table 2 Input codes 05**

Code	Displayed Name	Description	General
05-100	DADF Doc. Detect Sensor	DADF document detect sensor (Q05-100), detects if a document is present.	High = document present Low = no document
05-120	DADF Paper Length Sensor	DADF paper length sensor (Q05-120), (Q05-100), detects if a document is present.	High = document present Low = no document
05-130	DADF Registration Sensor	DADF document registration sensor (Q05-130), detects if a document is present.	High = document present Low = no document
05-140	DADF Scan Sensor	DADF document scan sensor (Q05-140), detects if a document is present.	High = document present Low = no document
05-160	DADF Door Open Sensor	DADF door open sensor (Q05-150), detects if the DADF door is open.	High = door open Low = door closed

**Table 3 Input codes 06**

Code	Displayed Name	Description	General
06-110	LSU Motor Ready	Detects if the LSU motor (MOT06-100) is running at normal speed.	High = running at normal speed Low = not running at normal speed

**Table 4 Input codes 07**

Code	Displayed Name	Description	General
07-110	T1 Paper Empty Sensor	Tray 1 paper empty sensor (Q07-110), detects if there is paper present in tray 1.	High = tray empty Low = paper present
07-210	T2 Paper Empty Sensor	Tray 2 paper empty sensor (Q07-210), detects if there is paper present in tray 2.	High = tray empty Low = paper present
07-510	Bypass Paper Empty Sensor	Bypass paper present sensor (Q07-510), detects if there is paper present in the bypass tray.	High = Tray empty Low = Paper present

**Table 5 Input codes 08**

Code	Displayed Name	Description	General
08-100	Feed Sensor	Detects when the lead edge of the paper is at the feed sensor (Q08-100).	High = paper present Low = no paper
08-500	Regi. Sensor	Detects when the lead edge of paper is at the registration sensor (Q08-500).	High = paper present Low = no paper
08-600	Exit Sensor	Detects when the lead edge of paper is at the fuser exit sensor (Q08-600).	High = paper present Low = no paper
08-700	Duplex Jam 1 Sensor	Detects when there is paper at the duplex jam 1 sensor (Q08-700).	High = paper present Low = no paper
08-720	Out-Bin Full Sensor	Detects when the paper is at the out bin full sensor (Q08-720).	High = paper present Low = no paper

**Table 6 Input codes 09**

Code	Displayed Name	Description	General
09-310	THV Bias Read	Detects the THV value on the transfer roller.	Displays THV value = XXX

**Table 7 Input codes 10**

Code	Displayed Name	Description	General
10-200	Fuser Temperature A	Measures the fuser temperature at the thermistor.	Displays temperature in degrees C = XXX

**Output Codes**

**Table 8 Output codes 04**

Code	Displayed Name	Description	General
04-100	Main BLDC Motor	Energizes the main BLDC motor (MOT04-100).	On/Off.
04-120	Main Fan	Energizes the main fan	On/Off
04-200	Exit Motor Forward Fast	Energizes the exit motor (MOT04-200) in reverse.	On/Off.
04-210	Exit Motor Forward Slow	Energizes the exit motor (MOT04-200) forward slowly.	On/Off.
04-300	Duplex Motor Forward	Energizes the duplex motor (MOT04-300) forward.	On/Off.

**Table 9 Output codes 05**

Code	Displayed Name	Description	General
05-200	DADF Scan Motor Forward	Energizes the DADF scan motor (MOT05-200) forward.	On/Off.

**Table 9 Output codes 05**

Code	Displayed Name	Description	General
05-201	DADF Scan Motor Reverse	Energizes the DADF scan motor (MOT05-200) in reverse.	On/Off.
05-300	DADF Pick-Up Solenoid	Energizes the DADF document pick-up solenoid (SOL05-300).	On/Off.
05-310	DADF Regi. Solenoid	Energizes the DADF registration solenoid (SOL05-310).	On/Off.
05-320	DADF Lift Solenoid	Energizes the DADF lift solenoid	On/Off
05-500	Scan Edge Print	Print edge scanning	

**Table 10 Output codes 06**

Code	Displayed Name	Description	General
06-100	LSU Motor Run	Energizes the LSU motor (MOT06-100).	On/Off.
06-200	LSU LD Power	Switches on or off the LSU power supply.	On/Off.

**Table 11 Output codes 08**

Code	Displayed Name	Description	General
08-800	Bypass Feed Solenoid	Energizes the bypass tray feed solenoid (SOL08-800).	On/Off.
08-810	T1 Pick-Up Solenoid	Energizes the tray 1 pick up solenoid (SOL08-810).	On/Off.
08-820	T2 Pick-Up Solenoid	Energizes the tray 2 pick up solenoid (SOL08-820).	On/Off.
08-850	Registration Clutch	Energizes the registration clutch (CL08-850).	On/Off.
08-920	T2 Feed Motor Run	Energizes the tray 2 motor (MOT08-920).	On/Off

**Table 12 Output codes 09**

Code	Displayed Name	Description	General
09-100	MHV Bias	Energizes the charge bias voltage.	On/Off.
09-200	Dev Bias	Energizes the developer bias voltage	On/Off.
09-300	THV (+) Bias	Energizes the positive transfer bias voltage.	On/Off.
09-400	THV (-) Bias	Energizes the negative transfer bias voltage.	On/Off.
09-500	SMPS Fan Run	Energizes the SMPS fan.	On/Off.

**Table 13 Output codes 10**

Code	Displayed Name	Description	General
10-100	Fuser Power On	Energizes the fuser to operating temperature (180 degrees).	On/Off.
10-500	Fuser Fan Run	Energizes the fuser fan.	On/Off.
10-600	Fuser Bias	Fuser bias voltage on at normal drive level	On/Off

**Table 14 Output codes 20**

Code	Displayed Name	Description	General
20-012	Sngl Tone 1100Hz Ln1	Emits a single tone 1100Hz on line 1.	On/Off.
20-014	Sngl Tone 1650Hz Ln1	Emits a single tone 1650Hz on line 1.	On/Off.
20-015	Sngl Tone 1850Hz Ln1	Emits a single tone 1850Hz on line 1.	On/Off.
20-016	Sngl Tone 2100Hz Ln1	Emits a single tone 2100Hz on line 1.	On/Off.
20-020	DTMF # Line1	Emits DTMF # on line 1.	On/Off.
20-021	DTMF * Line1	Emits DTMF * on line 1.	On/Off.
20-022	DTMF 0 Line1	Emits DTMF 0 on line 1.	On/Off.
20-023	DTMF 1 Line1	Emits DTMF 1 on line 1.	On/Off.
20-024	DTMF 2 Line1	Emits DTMF 2 on line 1.	On/Off.
20-025	DTMF 3 Line1	Emits DTMF 3 on line 1.	On/Off.
20-026	DTMF 4 Line1	Emits DTMF 4 on line 1.	On/Off.
20-027	DTMF 5 Line1	Emits DTMF 5 on line 1.	On/Off.
20-028	DTMF 6 Line1	Emits DTMF 6 on line 1.	On/Off.
20-029	DTMF 7 Line1	Emits DTMF 7 on line 1.	On/Off.
20-030	DTMF 8 Line1	Emits DTMF 8 on line 1.	On/Off.
20-031	DTMF 9 Line1	Emits DTMF 9 on line 1.	On/Off.
20-040	V.21 300 bps Line1	Emits V.21 300 bps on line 1.	On/Off.
20-041	V.27ter 2400 bps Line1	Emits V27ter 2400 bps on line 1.	On/Off.
20-042	V.27ter 4800 bps Line1	Emits V27ter 4800 bps on line 1.	On/Off.
20-043	V.29 7200 bps Line1	Emits V.29 7200 bps on line 1.	On/Off.
20-044	V.29 9600 bps Line1	Emits V.29 9600 bps on line 1.	On/Off.
20-045	V.17 7200 bps Line1	Emits V.17 7200 bps on line 1.	On/Off.
20-046	V.17 9600 bps Line1	Emits V.17 9600 bps on line 1.	On/Off.
20-047	V.17 12000 bps Line1	Emits V.17 12000 bps on line 1.	On/Off.
20-048	V.17 14400 bps Line1	Emits V.17 14400 bps on line 1.	On/Off.
20-049	V.34 2400 bps Line1	Emits V.34 2400 bps on line 1.	On/Off.
20-050	V.34 4800 bps Line1	Emits V.34 4800 bps on line 1.	On/Off.
20-051	V.34 7200 bps Line1	Emits V.34 7200 bps on line 1.	On/Off.
20-052	V.34 9600 bps Line1	Emits V.34 9600 bps on line 1.	On/Off.
20-053	V.34 12000 bps Line1	Emits V.34 12000 bps on line 1.	On/Off.
20-054	V.34 14400 bps Line1	Emits V.34 14400 bps on line 1.	On/Off.
20-055	V.34 16800 bps Line1	Emits V.34 16800 bps on line 1.	On/Off.
20-056	V.34 19200 bps Line1	Emits V.34 19200 bps on line 1.	On/Off.

**Table 14 Output codes 20**

Code	Displayed Name	Description	General
20-057	V.34 21600 bps Line1	Emits V.34 21600 bps on line 1.	On/Off.
20-058	V.34 24000 bps Line1	Emits V.34 24000 bps on line 1.	On/Off.
20-059	V.34 26400 bps Line1	Emits V.34 26400 bps on line 1.	On/Off.
20-060	V.34 28800 bps Line1	Emits V.34 28800 bps on line 1.	On/Off.
20-061	V.34 31200 bps Line1	Emits V.34 31200 bps on line 1.	On/Off.
20-062	V.34 33600 bps Line1	Emits V.34 33600 bps on line 1.	On/Off.
20-063	On Line Quiet State	Line connected, no signal on the line	On/Off.

## dC606 Internal Print Test Patterns

### Purpose

To print internal test patterns for image quality analysis.

### Procedure

**NOTE:** Refer to *IQ1 Image Quality Entry RAP* for information on the test patterns.

1. Enter diagnostics, GP 1.
2. Enter **Diagnostics Routines**.
3. Enter **Other Routines**.
4. Enter **606 Print Test Patterns**.
5. Select Image Quality Test Patterns 1 - 19.
6. Select the Features, 1 or 2 sided and the paper tray.
7. Touch the Start Test.

## Change Tags

### Purpose

To provide a list of all the tag numbers used together with a description of each of the machine modifications.

### Description

Each modification to the system is assigned a unique tag number. This section of the service documentation contains a listing and brief description of all change tags.

### Tag Information

Information that may be included with each tag item is as follows:

- Tag - gives the control number for the tag.
- Class - gives the classification codes as listed in Table 1.
- Use - indicates the multinational operating markets affected by the modification.
- Manufacturing Serial Number - gives the serial number of the factory built machines with the modification installed.
- Purpose - gives a brief description of the modification.
- Name - gives the name of the part or modification.
- Kit Number - gives the part number of the kit or part required to install the modification.
- Reference or Parts List On - indicates the parts list where the kit or modification part can be found.

### Mod / Tag Plate Location

The Mod / Tag plate is on the inside of the front cover assembly, PL 28.10 Item 7.

### Classification Codes

The Class or Classification code can be explained as follows:

Table 1 Classification codes

NASG code	XE code	Description
-	1	Safety: Install this tag immediately.
M	2	Mandatory: Install this tag at the next opportunity.
R	3	Repair: Install this tag as a repair, at the failure of a component.
O	4	Optional: Install as a customer option or a field engineering decision.
S	4	Situational: Install as the situation demands.
N	5	Manufacturing: Cannot be installed in the field.
	6	Refurbishing only.

## Machine Tags

**TAG: None issued**

CLASS: 5

NAME:

PURPOSE:

KIT NUMBER:

PARTS LIST ON: XX

### **Wiring Diagrams**

Wiring Diagrams..... 7-3

### **PWB Connector location**

PWB Connectors..... 7-15

# Wiring Diagrams

## Purpose

Wiring diagrams are an aid to trace wiring faults. Wiring Diagrams are used to complement the fault analysis information contained in the relevant RAP.

## Introduction

The PWB connections are shown in the following wiring diagrams:

- Input power and fuser, Wiring Diagram 1.
- HVPS, Wiring Diagram 2.
- Main PWB and scanner assembly, Wiring Diagram 3.
- Main PWB and user interface assembly, Wiring Diagram 4.
- Main PWB, print cartridge, LSU and foreign device interface, Wiring Diagram 5.
- Main PWB and connection PWB, Wiring Diagram 6.
- Main PWB, tray 2 connector and bypass feed assembly, Wiring Diagram 7.
- Main PWB and main drives assembly, Wiring Diagram 8.
- Connection PWB, stapler assembly and duplex drives assembly, Wiring Diagram 9.
- DADF, Wiring Diagram 10.
- Tray 2, Wiring Diagram 11.

The wiring diagrams have the following features:

- The connections on the PWBs are in numerical sequence where possible.
- The complete component to PWB wiring is shown. All interconnecting connectors shown, in part or whole. Connectors shown in part have reference to other wiring diagrams as necessary.
- Where necessary, components have references to show additional connections to them.
- Relevant parts list references are shown.

# Wiring Diagram 1

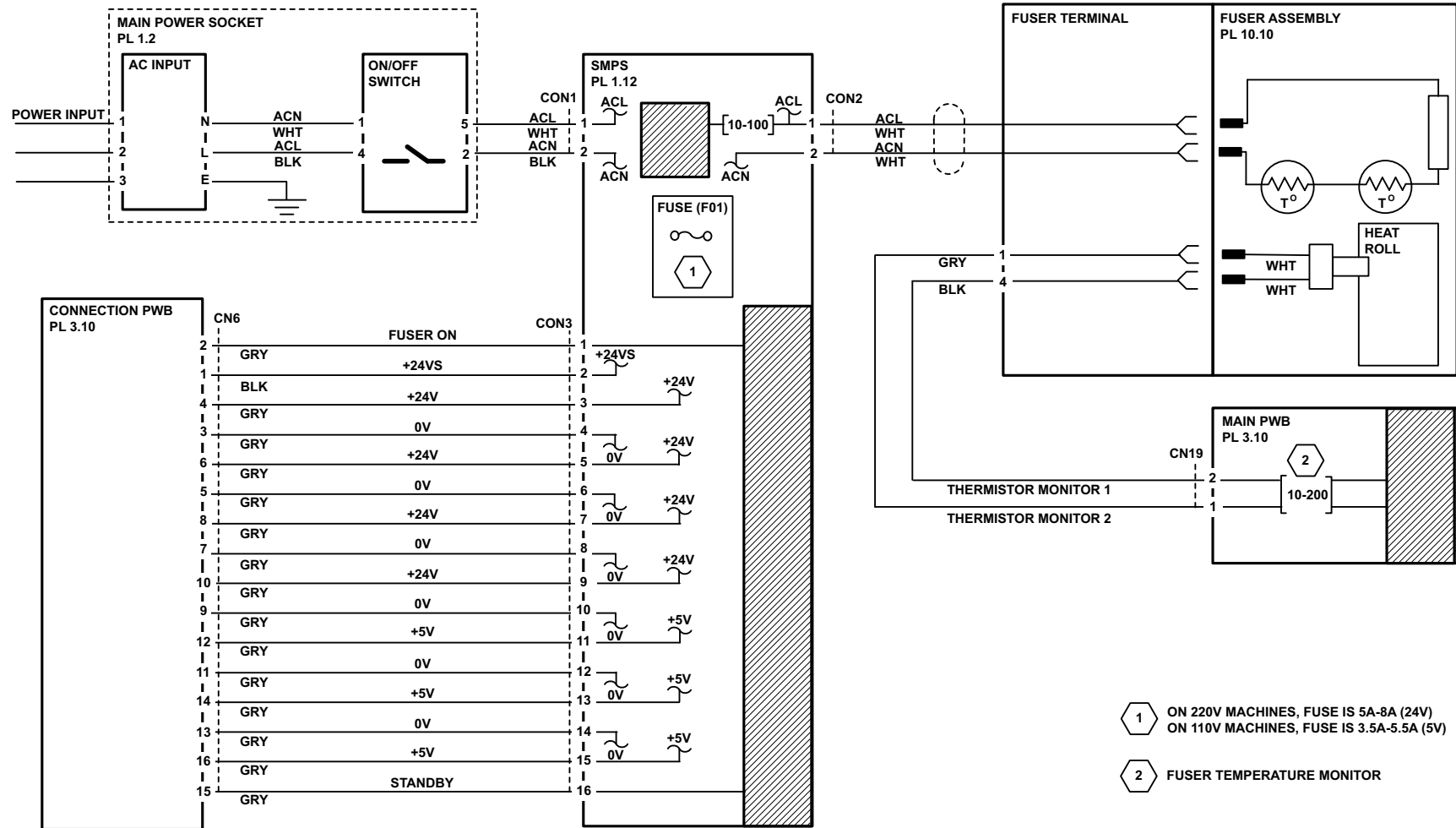

TAP-1-1511-A

Figure 1 Wiring Diagram 1

# Wiring Diagram 2

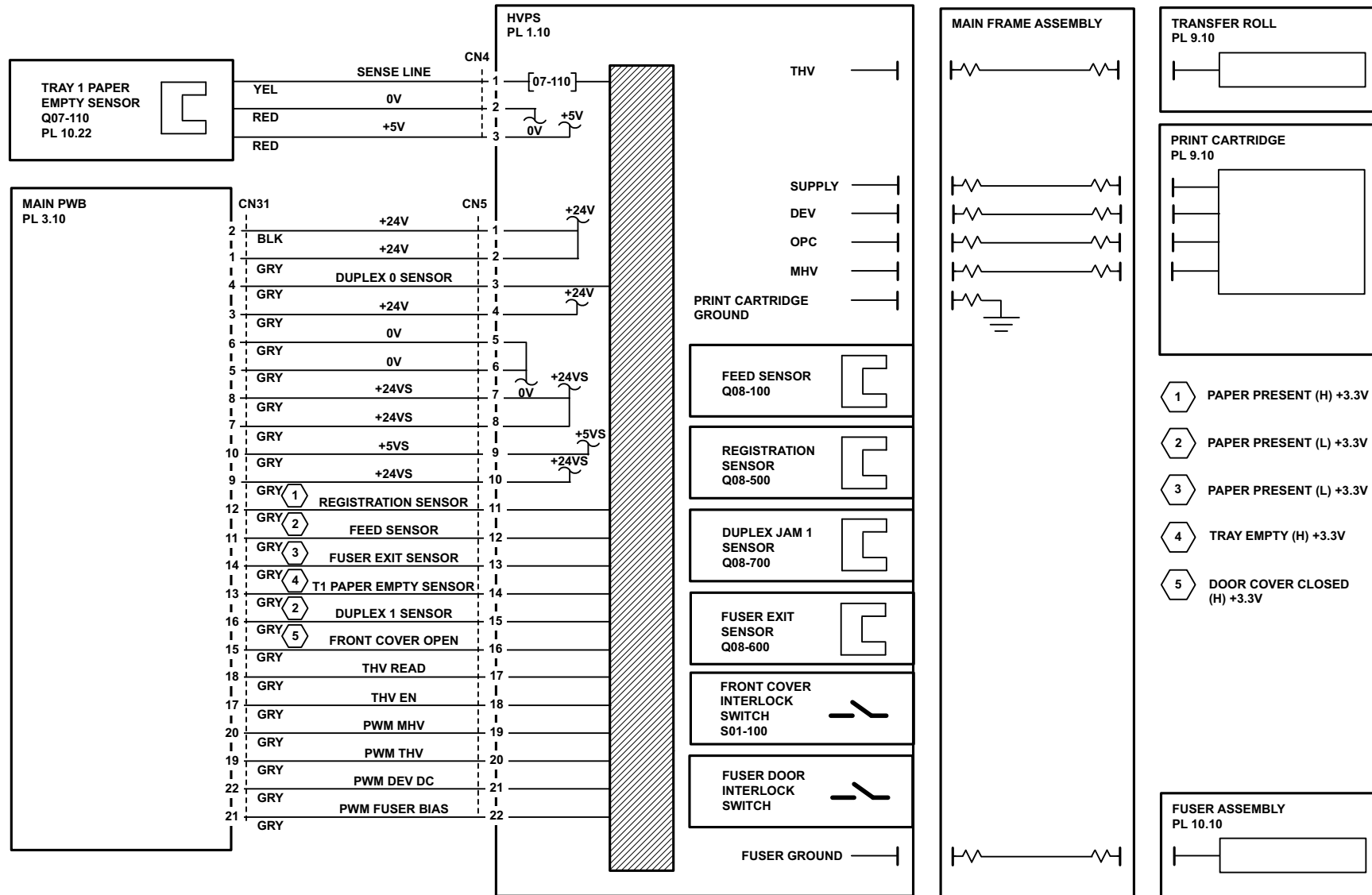

TAP-1-1501-A

Figure 2 Wiring Diagram 2

# Wiring Diagram 3

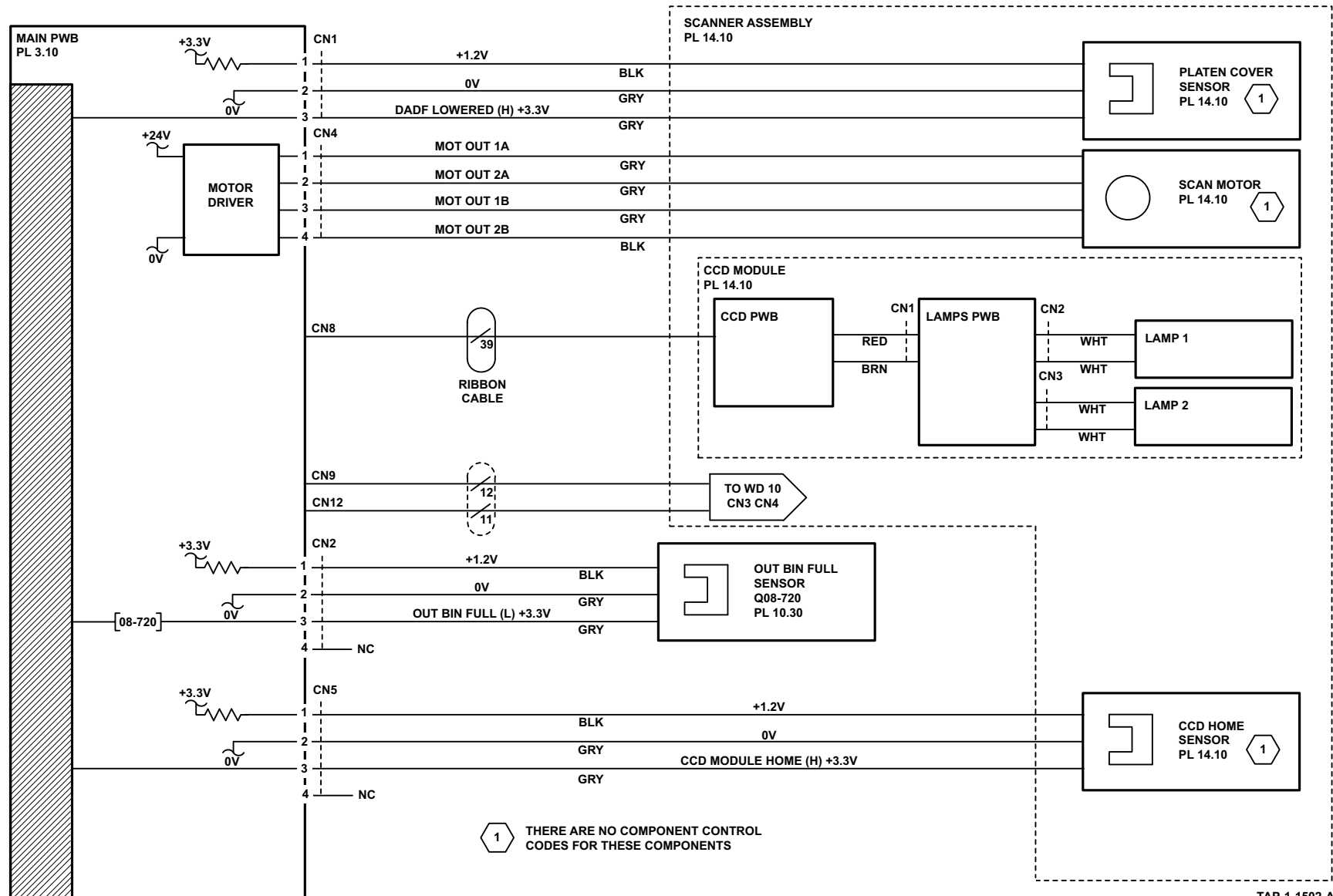

Figure 3 Wiring Diagram 3



# Wiring Diagram 5

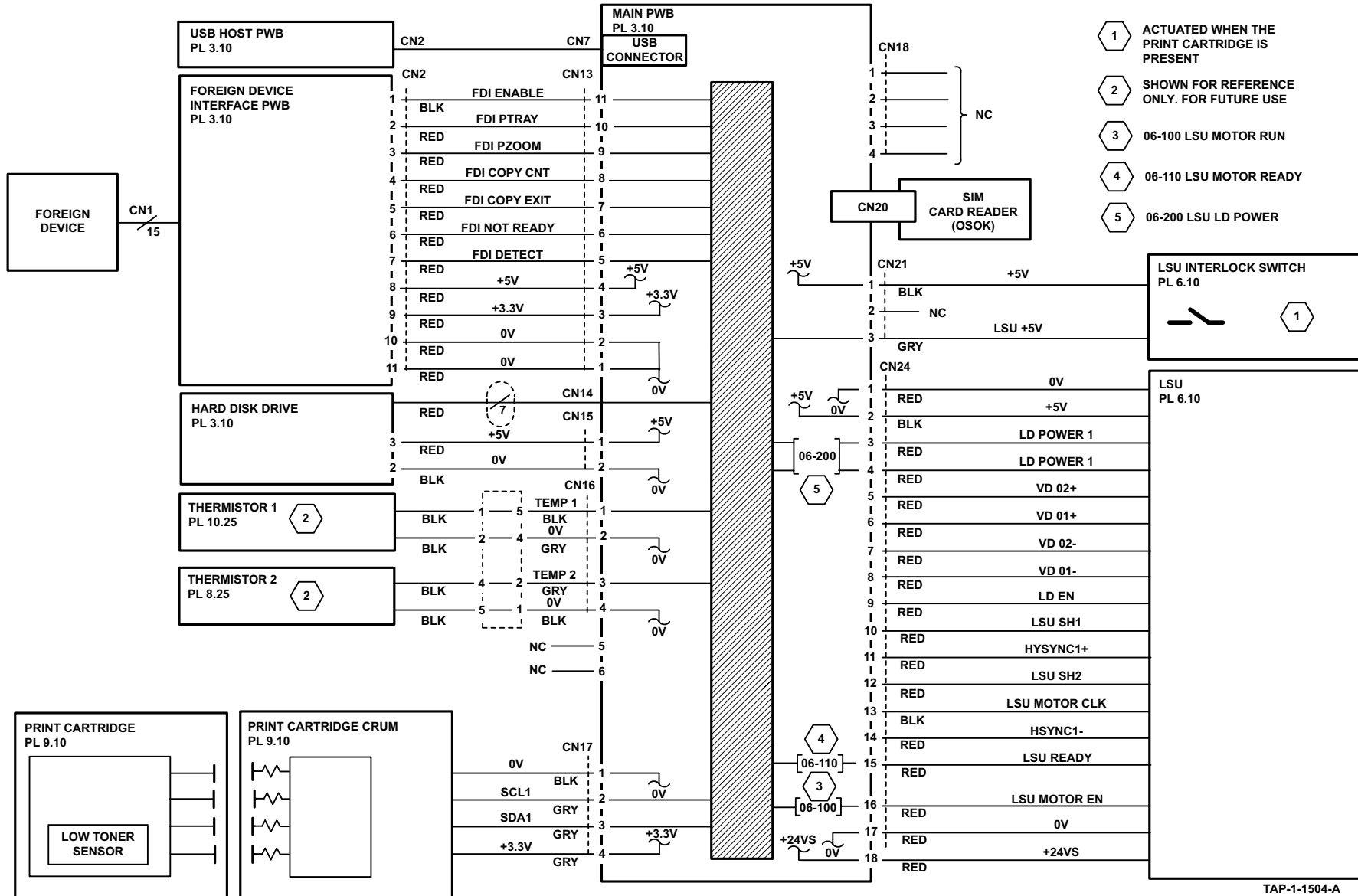
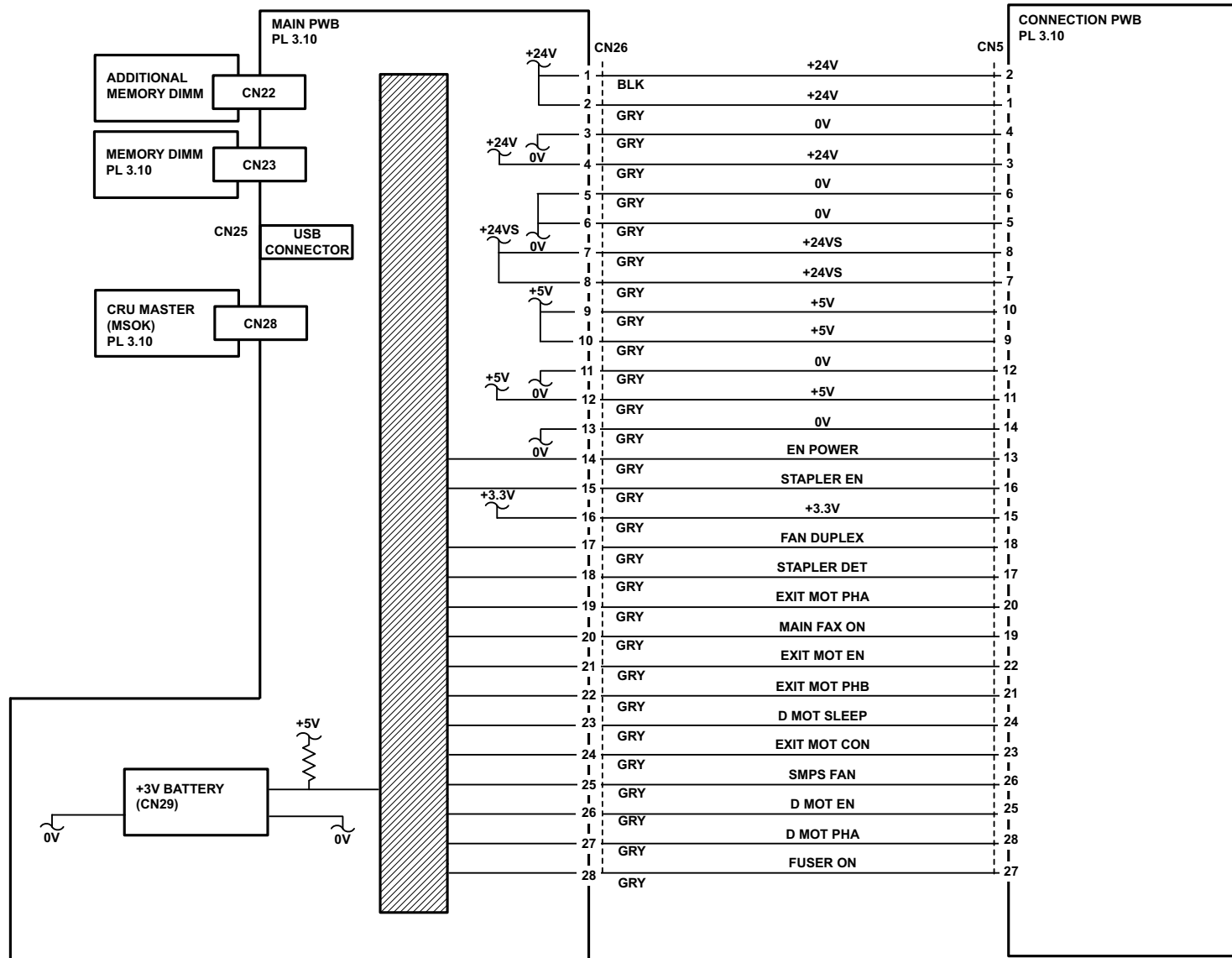

Figure 5 Wiring Diagram 5

# Wiring Diagram 6



TAP-1-1505-A

Figure 6 Wiring Diagram 6

# Wiring Diagram 7

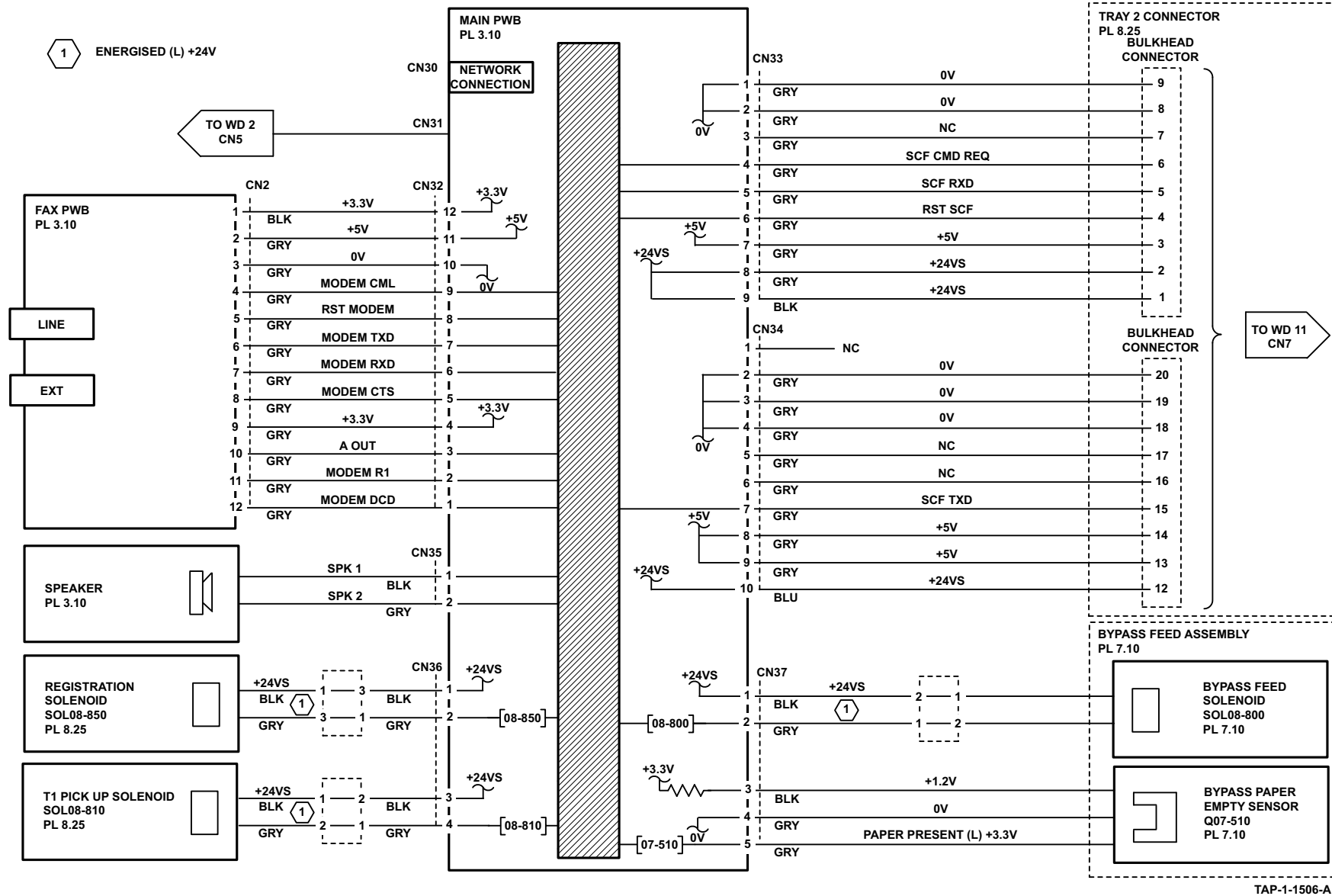
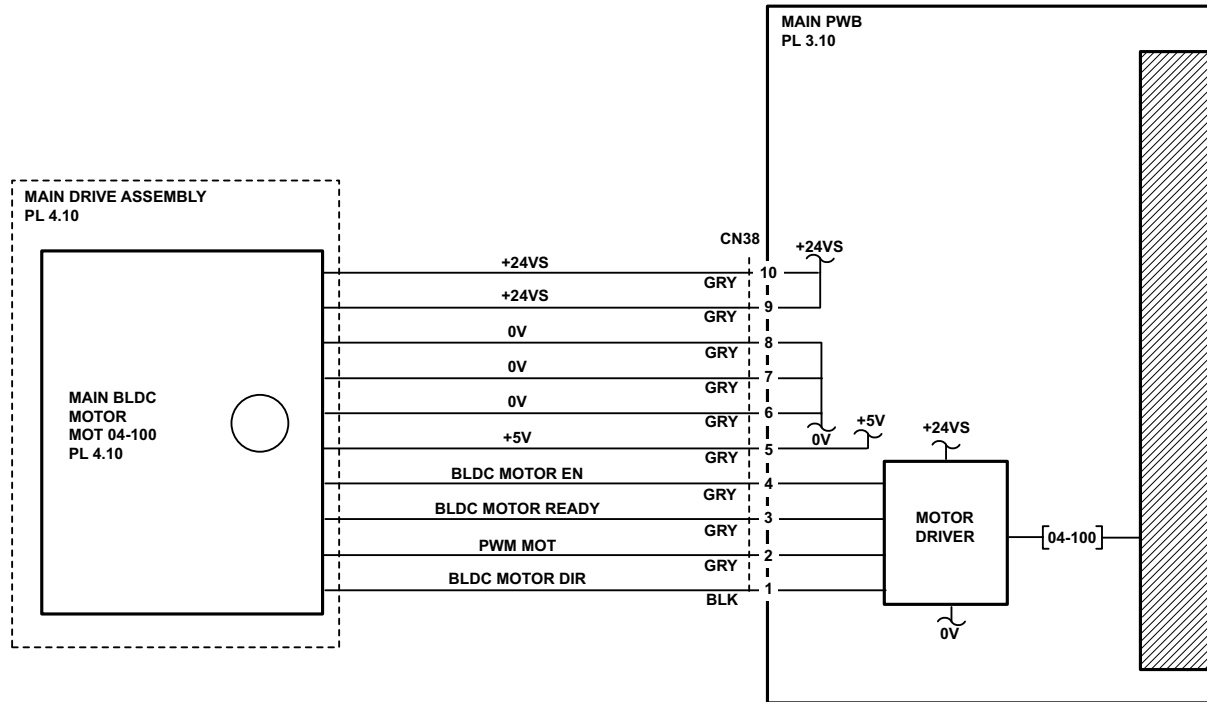

Figure 7 Wiring Diagram 7

# Wiring Diagram 8



TAP-1-1507-A

Figure 8 Wiring Diagram 8

# Wiring Diagram 9

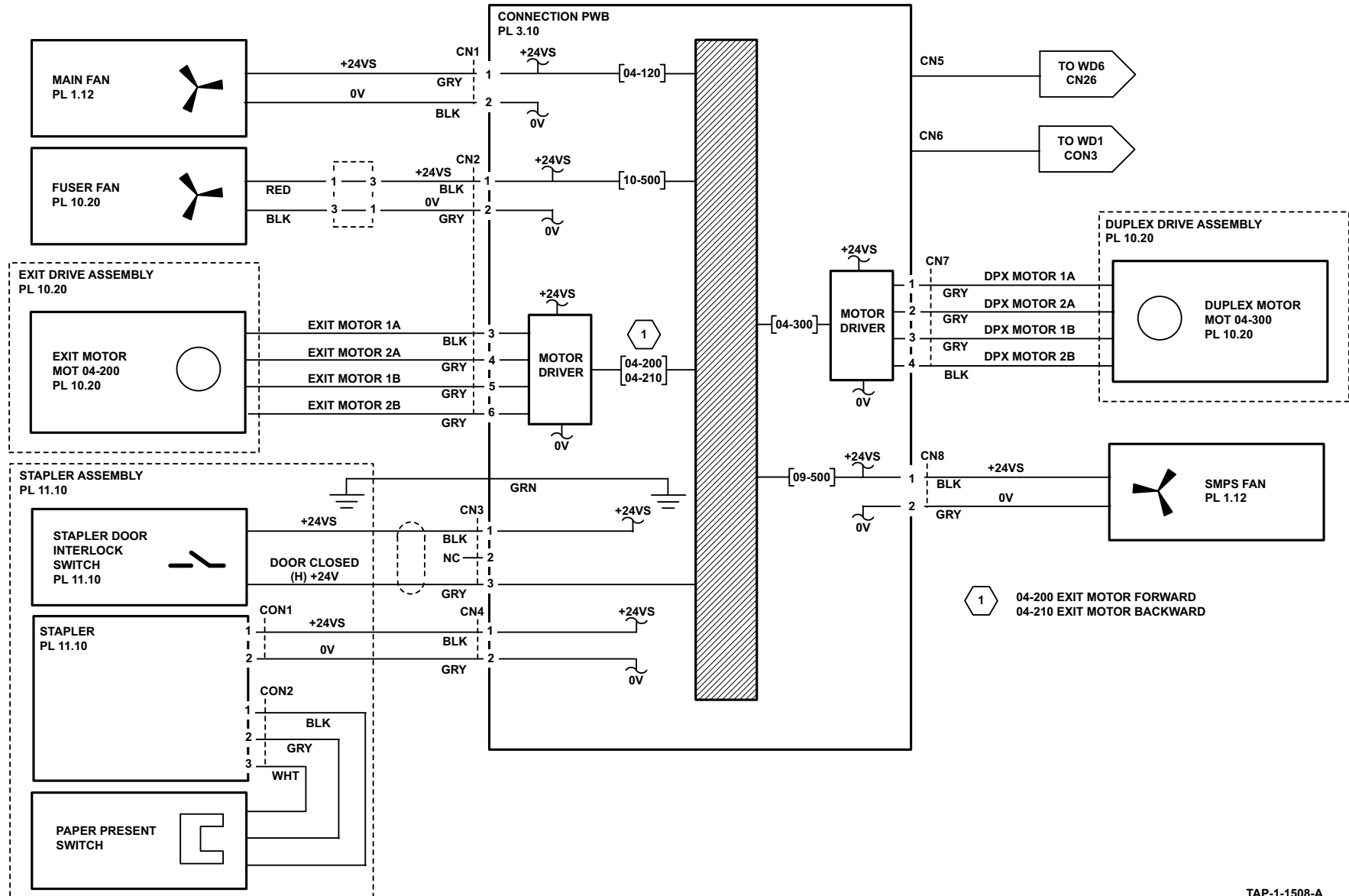

Figure 9 Wiring Diagram 9

TAP-1-1508-A

# Wiring Diagram 10

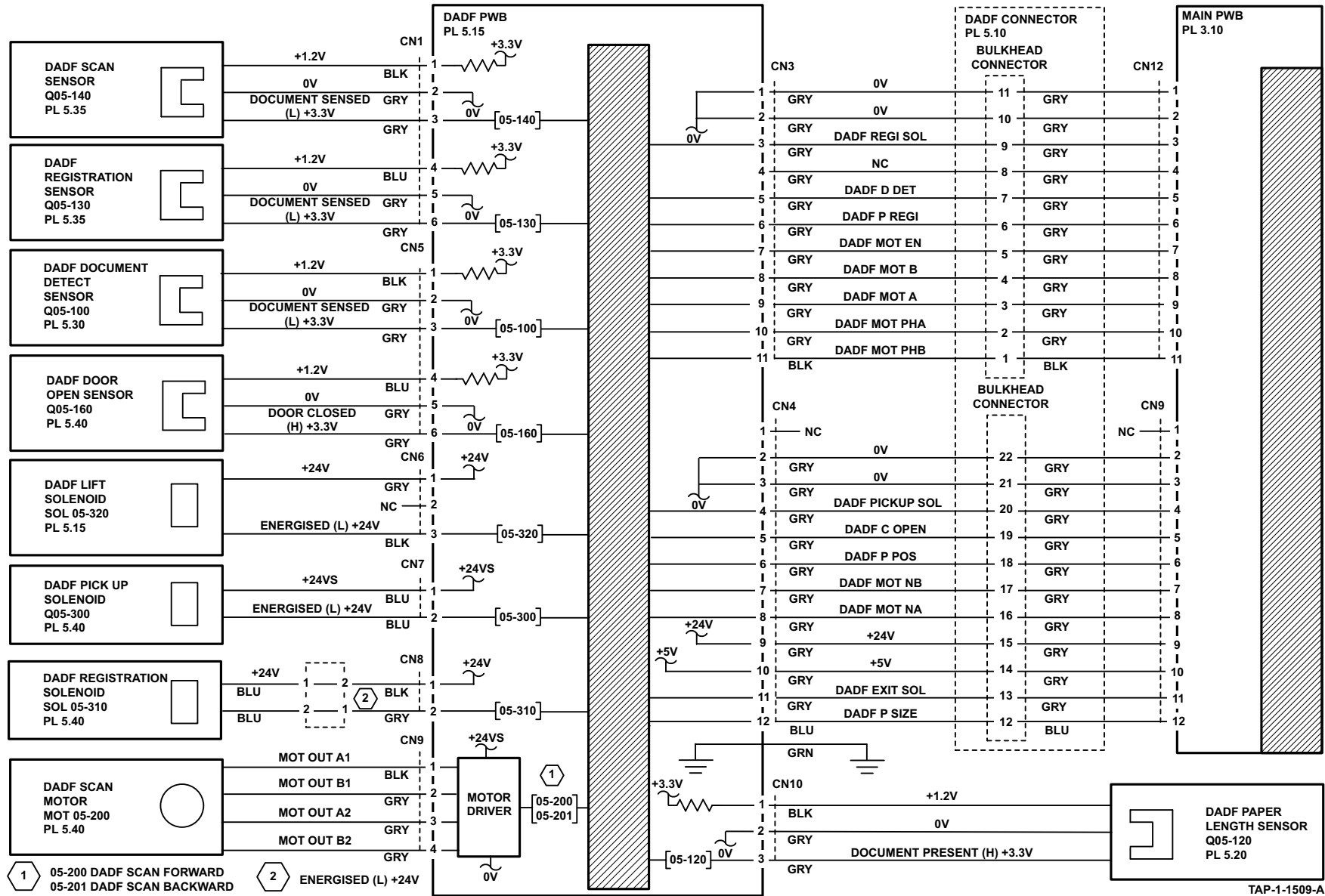
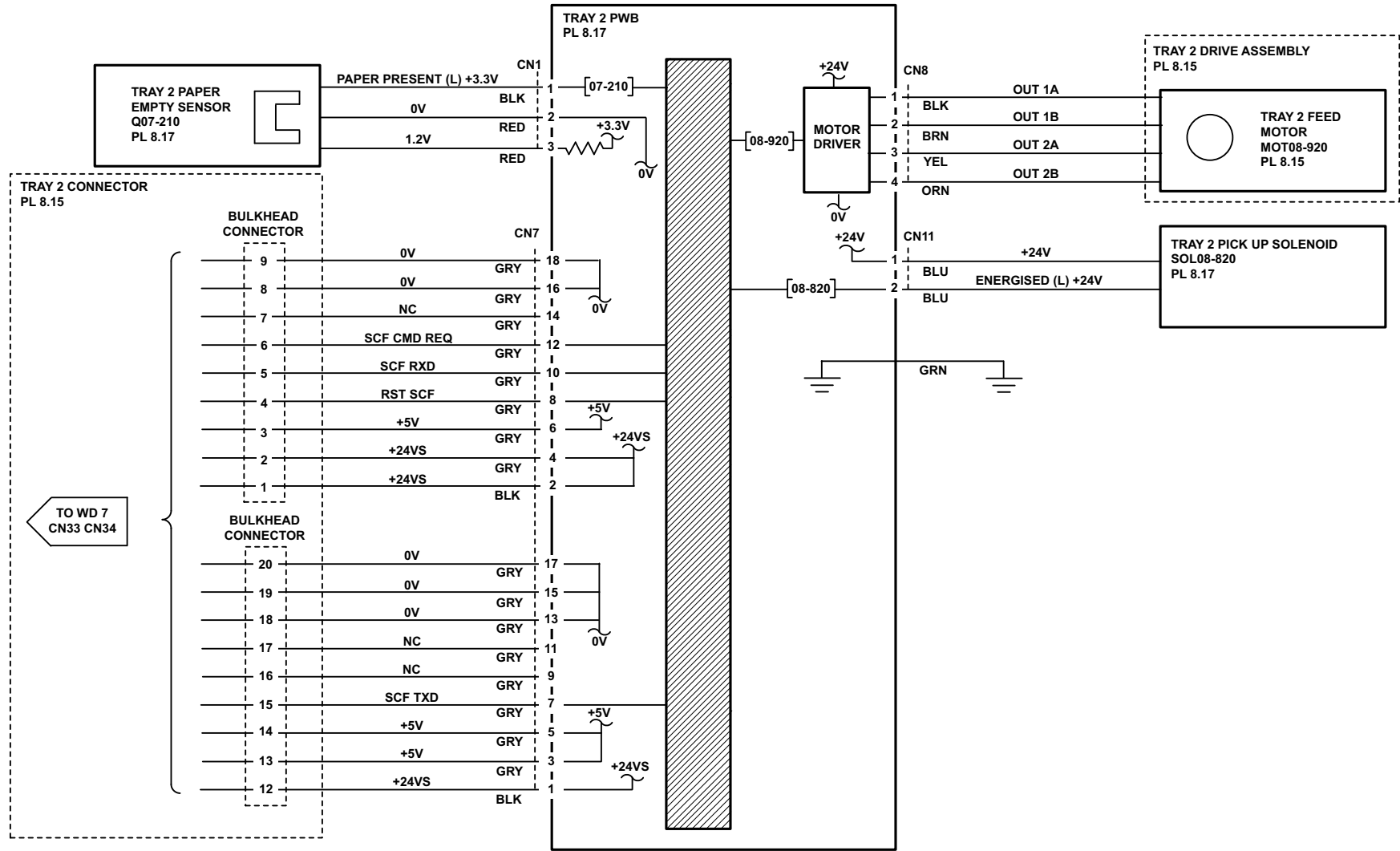

Figure 10 Wiring Diagram 10

# Wiring Diagram 11



TAP-1-1510-A

Figure 11 Wiring Diagram 11

## PWB Connectors

### Connector Locations

*NOTE: Part list references are given with each figure.*

1. SMPS, Figure 1.
2. HVPS, Figure 2.
3. Main PWB, Figure 3.
4. Connection PWB, Figure 4.
5. UI PWB, Figure 5.
6. DADF PWB, Figure 6.
7. Tray 2 PWB, Figure 7.

## SMPS

Location: PL 1.12 Item 8

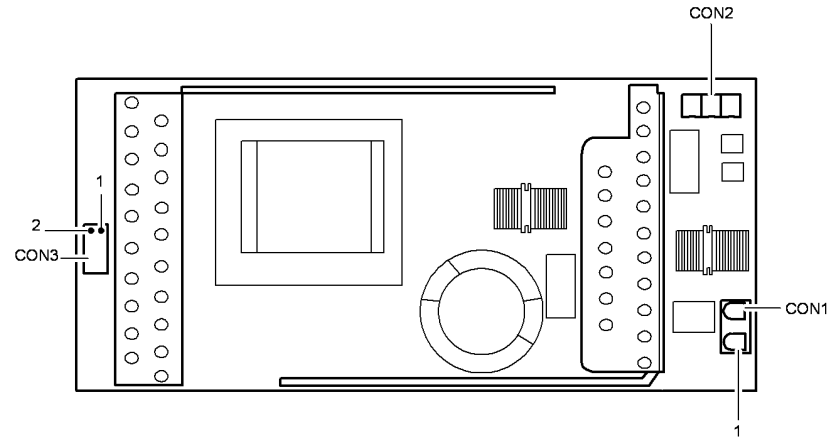

AP-1-1500-A

Figure 1 SMPS

**HVPS**

Location: PL 1.10 Item 3

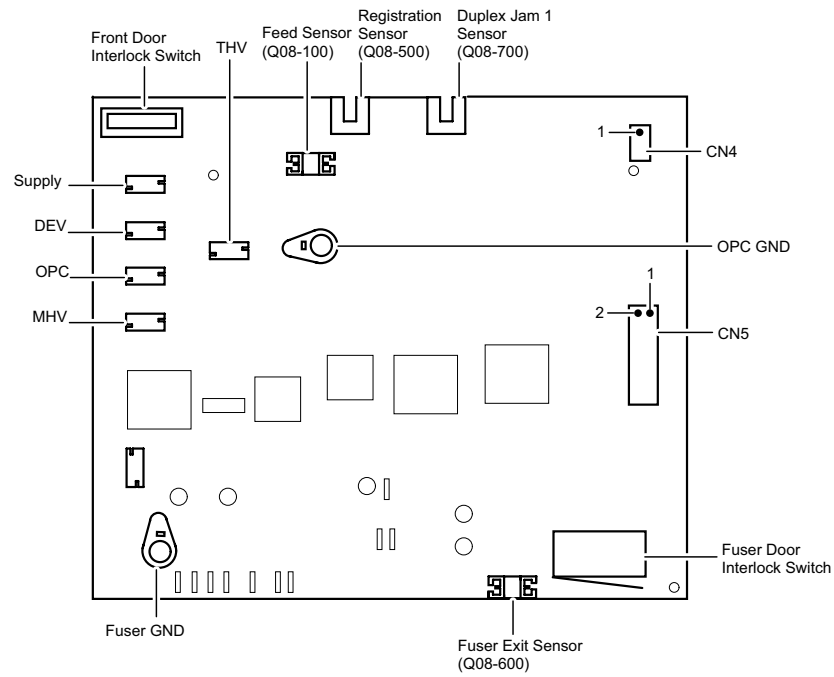

**Figure 2 HVPS**

**Main PWB**

Location: PL 3.10 Item 6

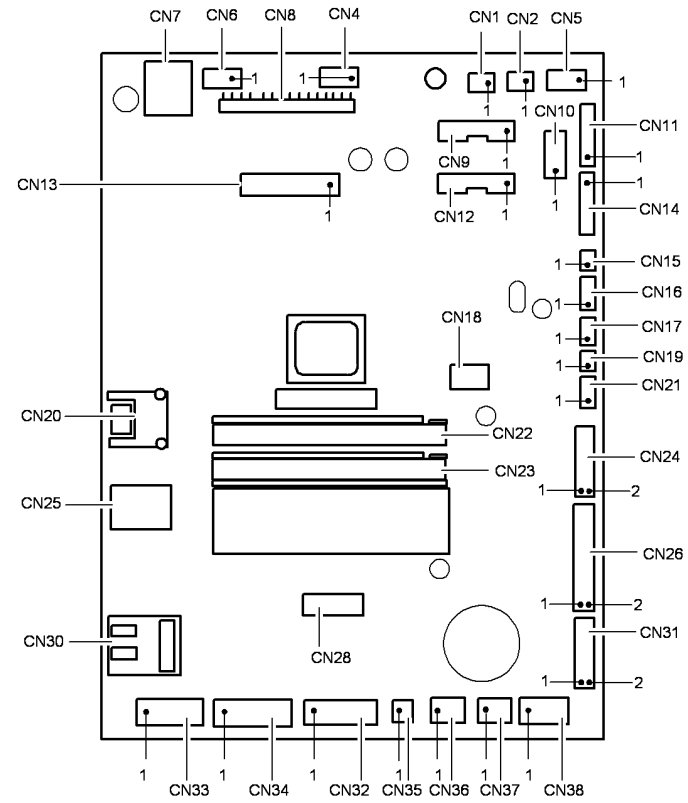
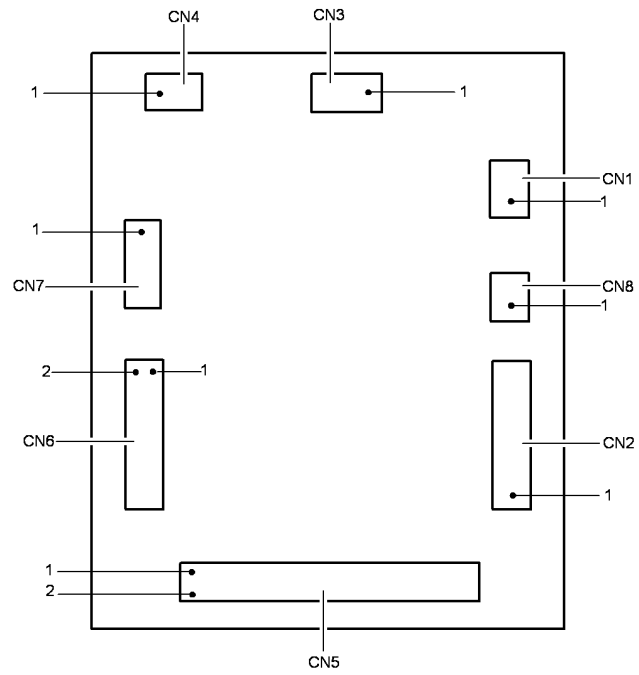

**Figure 3 Main PWB**

AP-1-1501-A

**Connection PWB**

Location: PL 3.10 Item 17



AP-1-1502-A

**Figure 4 Connection PWB**

**UI PWB**

Location: PL 2.10 Item 24

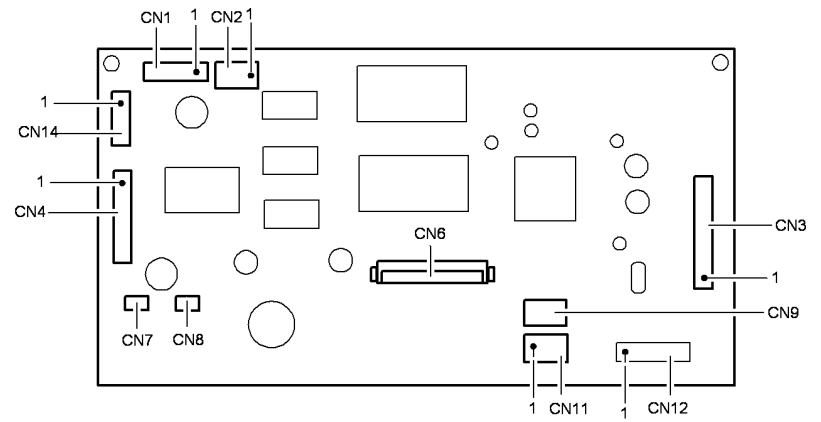

AP-1-1503-A

**Figure 5 UI PWB**

**DADF PWB**

Location: PL 5.15 Item 16

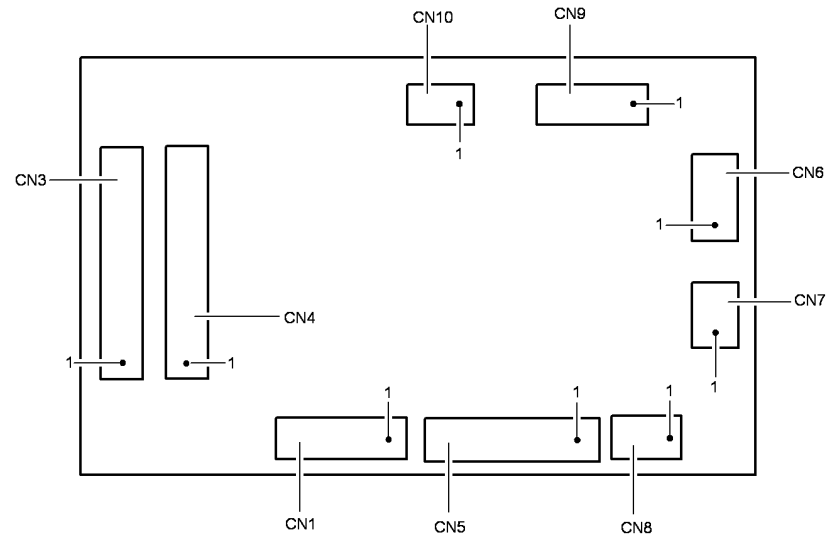

AP-1-1504-A

**Figure 6 DADF PWB**

**Tray 2 PWB**

Location: PL 8.17 Item 25

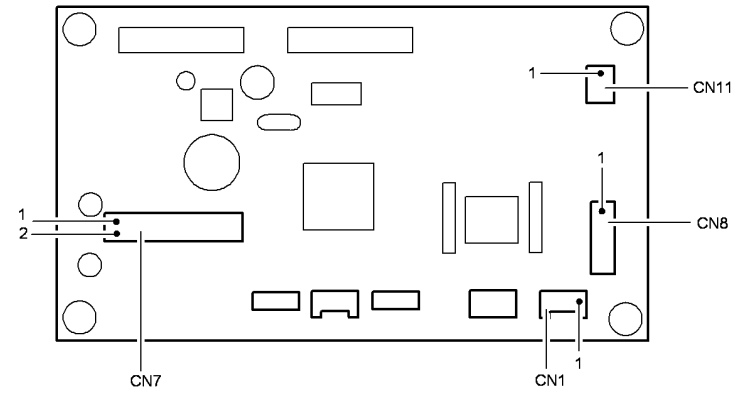

AP-1-1505-A

**Figure 7 Tray 2 PWB**

ACC 1 Foreign Device Interface Installation ..... 8-3

## **ACC 1 Foreign Device Interface Installation**

Refer to the Phaser 3635MFP foreign device installation kit for the installation procedure.